

AHP AIDED DECISION-MAKING IN VIRTUAL MACHINE MIGRATION FOR GREEN CLOUD

Liumei ZHANG

*School of Computer Science and Technology, Xidian University
2 South Taibai Road, Xi'an, Shaanxi, P.R. China 710071*

✉

*School of Computer Science, Xi'an Shiyou University
Xi'an, Shaanxi, P.R. China 710065
e-mail: rikrun@gmail.com*

Jianfeng MA

*School of Computer Science and Technology, Xidian University
2 South Taibai Road, Xi'an, Shaanxi, P.R. China 710071*

e-mail: jfma@mail.xidian.edu.cn

Tianshi LIU

*School of Computer Science, Xi'an Shiyou University
Xi'an, Shaanxi, P.R. China 710065*

e-mail: liutianshi@xsyu.edu.cn

Yichuan WANG, Di LU

*School of Computer Science and Technology, Xidian University
2 South Taibai Road, Xi'an, Shaanxi, P.R. China 710071*

e-mail: {ctechsky, nijino2002}@gmail.com

Abstract. In this study, an analytical hierarchy process based model is proposed to perform the decision-making for virtual machine migration towards green cloud computing. The virtual machine migration evaluation index system is established based on the process of constructing hierarchies for evaluation of virtual machine migration, and selection of task usage. A comparative judgment of two hierarchies

has been conducted. In the experimental study, five-point rating scale has been adopted to map the raw data to the scaled rating score; this rating method is used to analyze the performance of each virtual machine and its task usage data. The results show a significant improvement in the decision-making process for the virtual machine migration. The deduced results are useful for the system administrators to migrate the exact virtual machine, and then switch on the power of physical machine that the migrated virtual machine resides on. Thus the proposed method contributes to the green cloud computing environment.

Keywords: Green cloud computing, VM migration, AHP, decision support

Mathematics Subject Classification 2010: 68U35, 68Q87, 68Q99

1 INTRODUCTION

The ever developing cloud computing infrastructures always pose problems to environment safety and protection. The data center hosting cloud applications consume large amounts of energy, that results in high operating costs and carbon is released into the atmosphere [1]. The usage of clouds gives rise to the questions whether cloud computing is a cloud of pollution. The term green cloud computing has been defined to depict the study area focused on the alleviation of negative effects that cause the environmental burden. A number of researchers have presented a wide range of methods to support the green cloud.

In green cloud computing a number of factors have been considered such as power consumption, space occupancy and heat dissipation to achieve energy saving and environmental protection. Among all the factors, power consumption and heat dissipation are of the highest importance because these two factors have direct impact on the environment. The green cloud computing has gained appreciative popularity among academic researchers worldwide. The energy saving strategies for cloud computing platform were proposed in [2]. A framework is proposed to automatically manage resources of cloud infrastructures in order to reduce the amount of energy consumption to a minimum level [3]. Energy efficient multithreading local search algorithm is proposed for solving the multiobjective scheduling problem in heterogeneous computing systems [4]. Naturally, the best way to reduce the energy consumption and heat emission is to limit the usage of such infrastructure. More precisely, it is a good idea to switch off the cloud server when it is not in use. In the previous work [5], authors have proposed an attribute clustering based collaborative filtering method to generate the migration recommendation of the virtual machine (VM) for administrator. The presented method can calculate the similarities between defined target VM to migration and other VMs. However, it requires the administrator to manually perform the migration of VM. Therefore, it is unable to help the administrators to identify the exact VM to migrate according to their

criteria. The identification of the servers in a cluster to switch off is a challenging task. The cloud servers today are often the host of a bunch of virtual machines (VM); therefore, before shutting it down, a cloud server needs to be analyzed to secure the active running VMs. The active VMs can be migrated onto other running cloud servers before shutdown. Another challenging task is to determine whether a VM is active. Fortunately, the behavior of usage of a VM can be used to determine whether a VM is active. The cloud computing can enable more energy-efficient use of computing power, especially when the computing tasks are of low intensity or infrequent [6]. It is feasible to measure the VMs with task usage information; however, the decision of the VMs to migrate is still an open research problem. It is usually referred to as a decision-making problem.

The Analytical Hierarchy Process (AHP) [7] is a decision-making approach designed to aid the solution of complex multiple criteria problems in a number of application domains. This method has been found to be an effective and practical approach that can consider complex and unstructured decisions [8]. AHP has been widely used as a decision-making technique over various application domains [9, 10, 11, 12, 13, 14, 15]. In the cloud computing environment, AHP has also been applied to task scheduling and resource allocation [16], strategies of green energy saving [2], services ranking [17] and evaluation [18], quality of service [19], etc. In this study, the AHP is applied to aid the decision making in VM migration. The factors that affect the VM migration decisions are elicited to establish hierarchy for evaluation of VM resource usage. The administrators can judge the importance of each criterion in pair-wise comparisons; then, prioritized ranking or weighting of each VM migration alternative can be obtained. The task usage factor is dependent on various data types; however, only the CPU usage factor is considered in this study. Based on such factors, this study has focused on formulating an AHP-based model to select a VM which is suitable for migration onto another stable host. Hence, the cloud server with the rest of VMs can be powered off for energy saving.

The rest of this paper is organized as follows. Section 2 introduces the essential network topology of typical cloud computing. In Section 3 index system establishment and its analysis are presented and the comparative judgement analysis of the index system is provided. Section 4 describes the algorithm. The simulation and the experimental results are discussed in Section 5. Section 6 concludes the paper.

2 NETWORK TOPOLOGY

The virtual machines cannot operate as an independent system. They reside on the virtual machine manager (VMM) of the physical machine which is further connected by core switches in a cloud server cluster. Furthermore, the core switches are connected with migration manager (MM) for decision-making of VM migration strategy. In other words, the MM is responsible for the determination when and which the VM to be migrated. A server cluster often employed with firewalls serves

the Internet via routers. This paper presents a strategy to resolve the configuration problem within MM. For energy saving purposes, when the cluster server has light load, some of the VMs are migrated onto other physical running server and the idle physical machines are powered off. Figure 1 illustrates the typical network topology of a cloud server cluster; where the Physical Machine (PS), Migration Manager (MM), Virtual Machine (VM), Switcher (SW), Firewall (FW), and Router (R) are clearly presented.

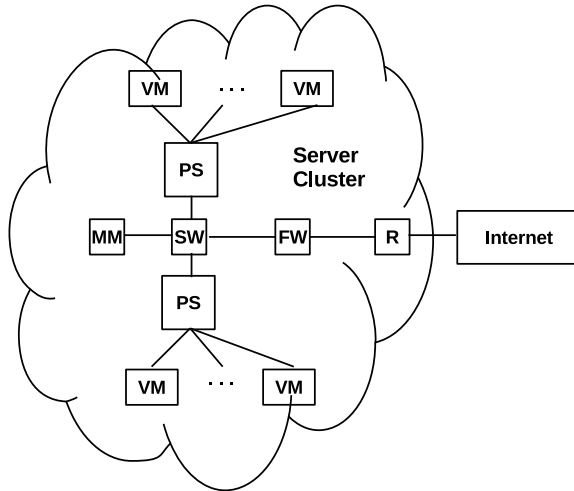

Figure 1. Network topology

The migration process of a VM falls into two categories: the “cold” and “hot” migration techniques. The “cold” migration indicates the VM needs to be powered off before migration. It will be rebooted on the destination physical server after the migration process. On the other hand, “hot” migration indicates the VM needs to be halted before the migration. It will be activated on the destination physical server after the migration process. The “hot” migration VM has very short service interruption time, often counted less than a hundred ms. Therefore, “hot” migration techniques are more common than the “cold” migration techniques. For clarity, the “hot” migration steps are given as follows.

1. MM decides the migration, and the destination physical machine for a VM,
2. halts the VM to migrate,
3. copies the entire memory mapping and CPU register status onto physical server,
4. registers the migration VM on the VMM of the destination physical server,
5. activates the migration VM on the VMM of the destination physical server,
6. switches off the original VM on the source physical server.

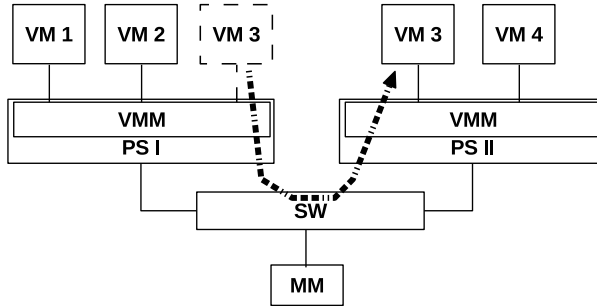

Figure 2. Migration of VM

3 VM MIGRATION EVALUATION MODEL

As the cloud service subscribers are increasing and the costs of the rent of such services are decreasing, VMM may contain the VMs that are infrequently used or idle long-term. Keeping such VMs together with frequently used VMs running on the same VMM is worthless. Particularly, when the number of idle VMs is greater than the number of frequent VMs, much power is wasted to keep the idle VMs alive. In order to alleviate the power consumption of cloud cluster, the PS can be powered off once the frequently used VMs is defined and migrated. On the other hand, the resource usage of receiving PS can also be maximized to improve the power performance of the system. All the VMs shall be evaluated according to certain criterion that reflects the utilization rate before deciding which of the VMs can be migrated. Thus, the frequently used VMs migration is considered as a decision-making problem in this study. The applications of AHP to complex decision situations have numbered in thousands [20], and it has produced extensive results in problems involving planning, resource allocation, priority setting, and selection among alternatives. Other areas include forecasting, total quality management, business process re-engineering, quality function deployment, and the balanced scorecard [21]. Therefore, in this paper, the AHP is adopted for the evaluation of VMs to find out the suitable migration VM according to the specified criteria of cluster administrator. Basically, there are three steps needed to apply the AHP to decision-making problems: constructing hierarchies; comparative judgment; and synthesis of priorities [22].

3.1 Establishment of VM Evaluation Index System

The construction of hierarchies requires eliciting the indicators for building an index system. Such system can be a comprehensive measurement for the scale sets towards the object. It is also a system analysis method that has been well accepted among many application domains such as social, economic and management science. The evaluation system often has a hierarchical structure, which contains two levels to form a multi-level evaluation system: the objectives and the principles.

For constructing hierarchies, the indicators that reflect properties which are helpful for VM migration need to be elicited. The goal of such model is the evaluation of VM migration. The CPU usage and cyclicity are considered as two performance criteria. The CPU usage consists of two sub-criteria including the average CPU rate and maximum CPU rate. The cyclicity consists of two sub-criteria including cycles per instruction and task duration. Figure 3 shows the hierarchy with VMs as the alternatives.

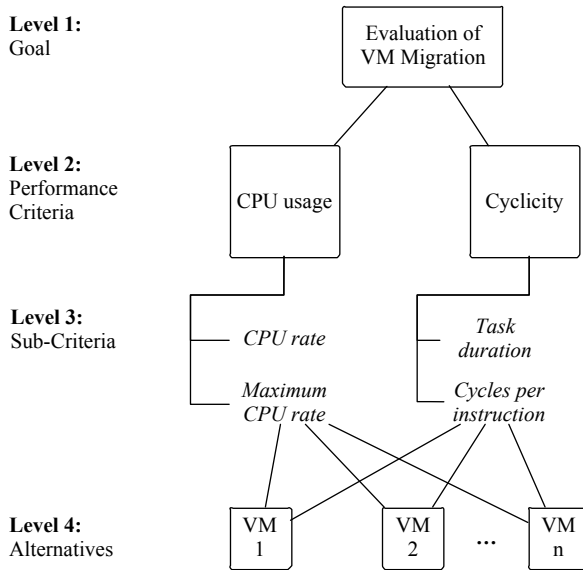

Figure 3. VM migration evaluation hierarchy

From the hierarchy shown in Figure 3 the VMs which are feasible to migrate can be obtained by the ranking result produced in AHP calculation. However, the VMs execute tasks from time to time. Therefore, a single task usage information cannot represent the exact behavior of a VM. A single task usage of VM consists of arbitrary task vectors. For this reason, a second hierarchy is proposed to select the most representative task usage. The configuration of the hierarchy is presented in Figure 4.

It can be seen that the Figure 4 is partially similar to Figure 3, and the goal of such evaluation is to select most representative task usage information. This information is obtained through the performance criteria. Similarly, CPU usage and the cyclicity are main indicators for task measurement. In addition, a new factor called task validity has been introduced to depict the time interval of a task from start to present. Task validity is used to describe that the completion time of a task execution to the time of AHP calculation. That is to say, for a same

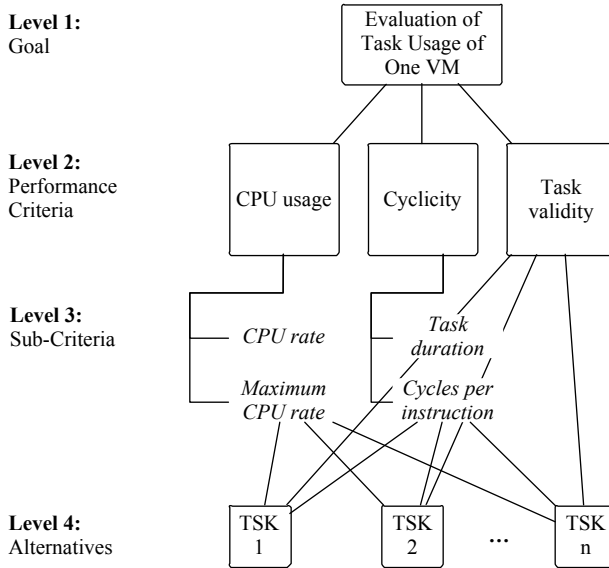

Figure 4. Task selection evaluation hierarchy

VM, if the completion time of a task execution is aged, then this task would be less representative than the task which executes recently.

3.2 Comparative Judgment

Once the hierarchy has been established, the comparative judgment needs to be implemented towards the referenced indicators. A pair-wise comparison is needed to formalize the weight of all indicators in this step.

Before such comparison, all the indicators should be analyzed and their influence upon VM migration must be established.

Definition 1 (Suitable/unsuitable for migration). A virtual machine (VM) is defined as suitable for migration where the VM consumes low CPU resources of a physical machine and the task duration is infrequent. A virtual machine (VM) is defined as unsuitable for migration where the VM consumes high CPU resources of a physical machine and the task duration is frequent.

When the average CPU rate of a virtual machine is low in a cloud cluster, the running cloud service consumes low CPU resources, or perhaps it is idle. This indicates that the migrated virtual machine will not take up much of the CPU resource of the receiving physical machine; such migration is helpful in saving power. Similarly, the virtual machine that has a low value of maximum CPU rate would behave the same way. On the other hand, a short CPU task duration indicates

the frequent CPU scheduling tasks on virtual machine. Therefore, if an infrequent is found, it should be migrated. The cycles per instruction describe the instruction type that CPU has executed. When the cycles per instruction are short, it may indicate the instruction is conventional, that includes the operation instruction, a short instruction and a short data operation instruction. Typically, those instructions are only used for calling register. In this situation, the virtual machine can be migrated for a long-term operation. A long cycle per instruction indicates that the co-processor is required for large data operation or an abnormal control transfer is executed. More precisely, the virtual machine will be terminated if the operation duration is not long. Therefore, it is unnecessary to migrate.

The criteria and sub-criteria identified as being important in the VM migration decisions can be summarized from Figures 3 and 4; it is provided in Table 1.

It can be concluded from Table 1 that the goals of proposed model are the evaluation of VM migration and task usage of the VM. For VM evaluation (G_1) task, the CPU usability (C_1) and cyclicity (C_2) are two criteria which further consist of CPU rate (C_{11}), maximum CPU rate (C_{12}), task duration (C_{21}) and cycles per instruction (C_{22}). For task usage evaluation (G_2) task, the CPU usability (B_1), cyclicity (B_2) and task validity (B_3) are the key criteria where CPU usability (B_1) and cyclicity (B_2) consist of CPU rate (B_{11}), maximum CPU rate (B_{12}), task duration (B_{21}) and cycles per instruction (B_{22}).

Goal	Criteria	Sub-Criteria
<i>VM evaluation (G_1)</i>	CPU usability (C_1)	CPU usage (C_{11}) Maximum CPU usage (C_{12})
	Cyclicity (C_2)	CPU task duration (C_{21}) Cycles per instruction (C_{22})
	<i>Task usage evaluation (G_2)</i>	CPU usability (B_1)
Cyclicity (B_2)		CPU task duration (B_{21}) Cycles per instruction (B_{22})
Task validity (B_3)		

Table 1. Criteria and sub-criteria of VM migration

When the cloud cluster administrator determines the migration of VMs for power saving reason, he may refer to the logs of VMs that resides in such VMM. The VMs can be pairwise compared using the comparison matrix technique. A comparison matrix can be built based on the Saaty Rating Scale [23], as shown in Table 2, which is used to determine the relative importance of each VM in terms of each criterion. Furthermore, the weights of all VMs can be derived using the AHP.

The pair-wise comparison matrices are developed to determine the weights of all criteria and sub-criteria. The weights for all the pairwise comparison matrices are then computed.

Intensity of Importance	Definition	Explanation
1	Equal importance	Two activities contribute equally to the objective.
3	Weak importance of one over another	Experience and judgment slightly favor one activity over another.
5	Essential or strong importance	Experience and judgment strongly favour one activity over another.
7	Demonstrated importance	An activity is strongly favoured and its dominance demonstrated in practice.
9	Absolute importance	The evidence favouring one activity over another is of the highest possible order of affirmation.
2, 4, 6, 8	Intermediate values between the two adjacent judgements	When compromise is needed.
Reciprocals of above nonzero	If activity i has one of the above nonzero numbers assigned to it when compared with activity j , then j has the reciprocal value when compared with i .	

Table 2. Saaty’s rating scale

	C_1	C_2	Weight
C_1	1	5	0.833
C_2	1/5	1	0.167
CR = 0			

Table 3. VM evaluation criterion comparison matrix

According to the definition, it is assumed that the cyclicity (C_2) has stronger importance compared with CPU usability (C_1). Thus, following reciprocal matrix is obtained.

$$G_1 = \begin{matrix} & \begin{matrix} C_1 & C_2 \end{matrix} \\ \begin{matrix} C_1 \\ C_2 \end{matrix} & \begin{bmatrix} 1 & 5 \\ & 1 \end{bmatrix} \end{matrix}$$

The reciprocal values of the upper diagonal are used to fill the lower triangular matrix. In other words, if g_{ij} is the element of row i column j of the matrix, then the lower diagonal is filled using $g_{ji} = \frac{1}{g_{ij}}$. Thus a complete comparison matrix is constructed.

$$G_1 = \begin{matrix} & \begin{matrix} C_1 & C_2 \end{matrix} \\ \begin{matrix} C_1 \\ C_2 \end{matrix} & \begin{bmatrix} 1 & 5 \\ \frac{1}{5} & 1 \end{bmatrix} \end{matrix}$$

Notice that all the elements in the comparison matrix are positive ($a_{ij} > 0$).

Then by applying the same method to the rest of criteria, all other comparison matrices for VM evaluation can be obtained as follows:

$$C_1 = \begin{matrix} & C_{11} & C_{12} \\ C_{11} & \begin{bmatrix} 1 & 7 \\ \frac{1}{7} & 1 \end{bmatrix} \\ C_{12} & \end{matrix}, \quad C_2 = \begin{matrix} & C_{21} & C_{22} \\ C_{21} & \begin{bmatrix} 1 & 5 \\ \frac{1}{5} & 1 \end{bmatrix} \\ C_{22} & \end{matrix}.$$

Moreover, all the matrices for task usage evaluation can also be obtained.

$$G_2 = \begin{matrix} & B_1 & B_2 & B_3 \\ B_1 & \begin{bmatrix} 1 & 7 & \frac{1}{2} \\ 7 & 1 & \frac{1}{7} \\ 2 & \frac{1}{7} & 1 \end{bmatrix} \\ B_2 & \\ B_3 & \end{matrix}, \quad B_1 = \begin{matrix} & B_{11} & B_{12} \\ B_{11} & \begin{bmatrix} 1 & 6 \\ \frac{1}{6} & 1 \end{bmatrix} \\ B_{12} & \end{matrix}, \quad B_2 = \begin{matrix} & B_{21} & B_{22} \\ B_{21} & \begin{bmatrix} 1 & 6 \\ \frac{1}{6} & 1 \end{bmatrix} \\ B_{22} & \end{matrix}.$$

3.3 Priority Vectors

Having all the comparison matrices, next step is to compute the priority vector, which is the normalized eigenvector of the matrix. The method adopted for priority vectors calculation is the approximation of eigenvector (and eigenvalue) of a reciprocal matrix. This approximation has worked well for small matrix. Nevertheless, it is easy to compute because it only requires normalization of each column of the matrix.

Summing each column of the reciprocal matrix of G_1 results in:

$$G_1 = \begin{matrix} & C_1 & C_2 \\ C_1 & \begin{bmatrix} 1 & 5 \\ \frac{1}{5} & 1 \end{bmatrix} \\ C_2 & \\ sum & \begin{bmatrix} \frac{6}{5} & 6 \end{bmatrix} \end{matrix}.$$

Then each element of the matrix is divided by the sum of its column to produce the normalized relative weight where the sum of each column is 1.

$$G_1 = \begin{matrix} & C_1 & C_2 \\ C_1 & \begin{bmatrix} \frac{5}{6} & \frac{5}{6} \\ \frac{1}{6} & \frac{1}{6} \end{bmatrix} \\ C_2 & \\ sum & \begin{bmatrix} 1 & 1 \end{bmatrix} \end{matrix}.$$

The normalized principal eigenvector [24] can be obtained by averaging across the rows.

$$\omega = \frac{1}{2} \begin{bmatrix} \frac{5}{6} + \frac{5}{6} \\ \frac{1}{6} + \frac{1}{6} \end{bmatrix} = \begin{bmatrix} 0.833 \\ 0.167 \end{bmatrix}.$$

The normalized principal eigenvector is also called priority vector. Since it is normalized, the sum of all elements in the priority vector is 1. The priority vector shows relative weights among the evaluation indicators that are compared. In this example, the values of C_1 is 83.33% and C_2 is 16.67%.

Then, by calculating all the pair-wised criteria addressed in Table 1, the results are summarized in Tables 3, 4, 5, 6, 7, 8 accordingly, where all the CRs are the consistency ratio of each of the comparison matrix. If the value of CR is smaller or equal to 10%, the inconsistency is acceptable. If the CR is greater than 10%, the subjective judgment needs to be revised.

The Maximum CPU usage (C_{12}) has a higher importance compared to the CPU usage (C_1) in Table 4. Similarly in Table 5, cycles per instruction (C_{22}) has a higher significance than the CPU task duration (C_{21}).

C_1	C_{11}	C_{12}	Weight
C_{11}	1	7	0.729
C_{12}	1/7	1	0.104
CR = 0			

Table 4. C_{11} and C_{12} comparison matrix

C_2	C_{21}	C_{22}	Weight
C_{21}	1	5	0.139
C_{22}	1/5	1	0.028
CR = 0			

Table 5. C_{21} and C_{22} comparison matrix

	B_1	B_2	B_3	Weight
B_1	1	7	1/2	0.363
B_2	7	1	1/7	0.066
B_3	2	1/7	1	0.571
CR = 0.0519				

Table 6. Task evaluation criterion comparison matrix

Table 6 illustrates that the task validity (B_3) is of less importance compared to CPU usability (B_1). On the other hand, the task validity (B_3) has demonstrated a higher importance than cyclicity (B_2), while in Table 7, compared with CPU usage (B_{11}), Maximum CPU usage (B_{12}) has a higher importance. Moreover, in Table 8, cycles per instruction (B_{22}) has a higher significance than CPU task duration (B_{21}).

4 ALGORITHM DESCRIPTION

Let us assume for a particular VM, O is the vector of raw task usage data of VM i in n dimension and J is the evaluation vector. $T(O, J)$ is the task scoring vector.

B_1	B_{11}	B_{12}	Weight
B_{11}	1	6	0.311
B_{12}	1/6	1	0.052
CR = 0			

Table 7. B_{11} and B_{12} comparison matrix

B_2	B_{21}	B_{22}	Weight
B_{21}	1	6	0.057
B_{22}	1/6	1	0.010
CR = 0			

Table 8. B_{21} and B_{22} comparison matrix

Each vector (task) has m dimensional attributes. Thus the vector of attributes is denoted as $A = [A_1 \dots A_n]^T$, $A_i = [a_1 \dots a_i \dots a_m]$, then A is a $n \times m$ matrix. The relative weight value is $W^A = [w_1 \dots w_i \dots w_m]$. V is assumed as the AHP value, then $V = A \times W^A$. V is a n dimensional vector. Thus, $\max(V)$ needs to be calculated, in other words obtain V_i^* where task V_i is the most representative task and index i is the task number. For each VM the above operation is applied, then $VM_j = V_i$ is the typical task of the j^{th} VM. Assuming there are N VMs, then vector $VM = [VM_1 \dots VM_N]$ represents all the typical task vectors of all the VMs. Next, the attributes processing is performed. The weight value $W^{VM} = [w_1 \dots w_i \dots w_N]$, $V^{VM} = A \times W^{VM}$ is an N dimensional vector. Thus, by finding $\max(V^{VM})$, V_i^{VM*} and related index i can be obtained resulting in VM_i as the target VM to migrate. The ‘‘AHP Decision Algorithm for VM Migration’’ is described in Algorithm 1.

Algorithm 1 AHP Decision Algorithm for VM Migration

- 1: Setup VMs and attributes matrix;
 - 2: **for** Each VM indexed as j in VMs set **do**
 - 3: Compute the AHP value $V = A \times W^A$;
 - 4: Find the index i where $V_i = \max\{V\}$;
 - 5: Set $VM_j = V_i$;
 - 6: $j = j + 1$
 - 7: **end for**
 - 8: Compute $V^{VM} = A \times W^{VM}$;
 - 9: Find the index i where $VM_i = \max\{V^{VM}\}$;
 - 10: Return i ;
-

5 SIMULATION RESULTS

This section demonstrates how the VM migration decisions are made using the proposed model. The simulation and experimental results also provide a feedback

to identify the points where the model can be improved to make it more usable and flexible. The model has been applied to Google clusterdata-2011-1 dataset [25], particularly to task usage data part-00000-of-00500.

Score	VL	L	M	H	VH	Relative Weight
Very Low (VL)	1	3	5	7	9	0.513
Low (L)	1/3	1	3	5	7	0.261
Moderate (M)	1/5	1/3	1	3	5	0.129
High (H)	1/7	1/5	1/3	1	3	0.063
Very High (VH)	1/9	1/7	1/5	1/3	1	0.034

Table 9. Rating scale for C_{11} , C_{12} , C_{22} , B_{11} , B_{12} and B_{22}

Score	VL	L	M	H	VH	Relative Weight
Very Short (VS)	1	3	5	7	9	0.513
Short (S)	1/3	1	3	5	7	0.261
Moderate (M)	1/5	1/3	1	3	5	0.129
Long (L)	1/7	1/5	1/3	1	3	0.063
Very Long (VL)	1/9	1/7	1/5	1/3	1	0.034

Table 10. Rating scale for C_{21} , B_{21} and B_3

Before using the proposed model on the Google cluster dataset, Liberatore’s [26] five-point rating scale is employed to rate each sub-factor of alternative VMs. It is better to reduce the time and effort in making pair-wise comparisons. Table 9 and Table 10 show the pair-wise comparison matrix of such rating scale. This matrix is then normalized to obtain the relative weight of each rating scale. The five-point rating factors are modified to use them for the measurement of the dataset. To normalize the raw data according to their values for the CPU rate, Maximum CPU rate and cycles per instruction attributes, the following scales are used: very-high, high, moderate, low and very-low. Similarly, for CPU task duration and task validity following scales are used: very-long, long, moderate, short and very-short. Then, the weights of very-high, high, moderate, low and very-low are calculated, which are equal to 0.513, 0.261, 0.129, 0.063 and 0.034, respectively. The weights of very-long, long, moderate, short and very-short are calculated in a similar manner. On the other hand, the attribute task validity is calculated in the same way with task duration.

As the next step, the dataset was preprocessed according to the proposed rating scale. The mean, maximum and minimum value are summarized according to the task usage data part-00000-of-00500. Moreover, five partitions are created for each attribute value range. A set of 5 VMs data is sampled from part-00000-of-00500. For each VM, 10 task usage samples are collected. Such dataset was sampled by using operators in Rapidminer 5.0. Consequently, the five-point ratings are assigned to the attribute with respect to the value of the raw data and corresponding partitions. Then the task usage of each VM is evaluated. Table 11 shows the task evaluation of

Criteria	Sub Criteria	Global Weights	Task 1		Task 2	
			Score	GW	Score	GW
B_1	B_{11}	0.311	VL = 0.513	0.160	VL = 0.513	0.160
	B_{12}	0.052	L = 0.261	0.014	VL = 0.513	0.027
B_2	B_{11}	0.057	VS = 0.513	0.029	VL = 0.034	0.002
	B_{11}	0.010	VL = 0.513	0.005	VL = 0.513	0.005
B_3		0.571	VL = 0.034	0.019	L = 0.063	0.359

Table 11. Single VM task usage evaluation

only one VM with only two tasks as the example. After all VMs been applied with such method, the most representative task usage information is obtained for each VM from 10 collected task usage samples.

Node ID	Task ID	Value
2994441279	10	0.497
587080532	10	0.474
17504375	10	0.411
4302816019	10	0.409
2568530361	9	0.367

Table 12. Task usage evaluation result

Criteria	Sub Criteria	Global Weight	Node 1		Node 2	
			Score	GW	Score	GW
C_1	C_{11}	0.729	VL = 0.513	0.160	VL = 0.513	0.160
	C_{12}	0.104	L = 0.261	0.014	VL = 0.513	0.027
C_2	C_{11}	0.139	VS = 0.513	0.029	VL = 0.034	0.002
	C_{11}	0.028	VL = 0.513	0.005	VL = 0.513	0.005

Table 13. VM evaluation

Table 12 shows the task with highest value after application of the proposed model. The task usage data is loaded into VM migration evaluation model. Table 13 shows the VM evaluation of VM with only two VMs as the example.

Obviously, after testing all the VMs against defined criteria, the VM with the highest value should be migrated first. Table 14 shows the related results: where VM with ID 2994441279 has the highest value. If it is assumed that all the tested VMs are on a same physical cloud server machine, VM 2994441279 and VM 587080532 shall be migrated as these two VMs has similar values. The similarity of the values may require other methods to further decide the migration; however, it is beyond the scope of this research topic.

It is observed that the usage of VM in a server obeys a normal distribution. That is, from 6:00 to 21:00 is the frequently used duration of the day, then from 21:00 to 6:00 is the infrequent period. Thus, normal distribution $\mathcal{N}(12, 0.7)$ is adopted as

VM ID	Task ID	Value
2994441279	10	0.478
17504375	10	0.282
4302816019	10	0.282
2568530361	9	0.179
587080532	10	0.426

Table 14. VM evaluation result

the probability distribution of usage scale of the physical machine, with 12 as the mean value and 0.7 as the standard deviation. Assuming there are 10 000 physical machines, with each having the maximal power of 500 W, the physical machine consumes 42 % electric power in infrequent period. The comparison of electric power consumption before and after migration is shown in Figure 5.

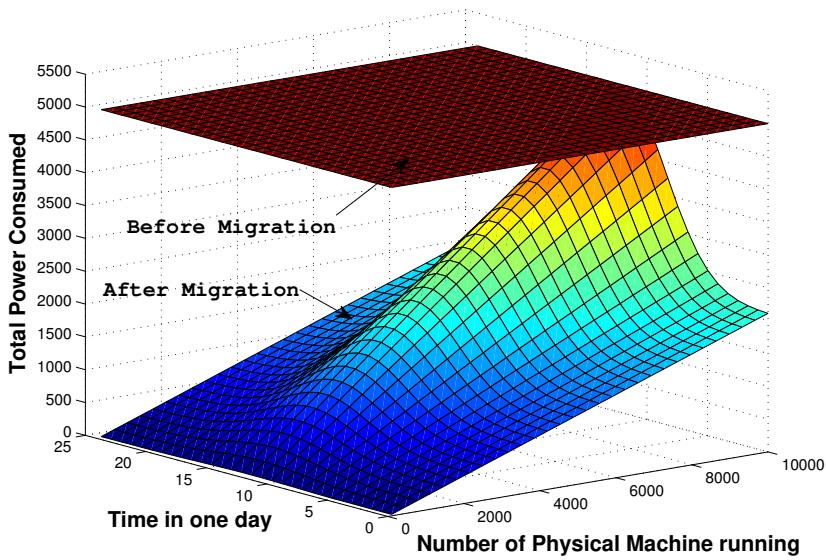

Figure 5. Power saving effectiveness verification

Assume t is the event when AHP algorithm is loaded, N is the total number of VMs, then the decision making consumes $t * N + t$ according to the proposed method. Thus Figure 6 shows the efficiency of the Algorithm 1.

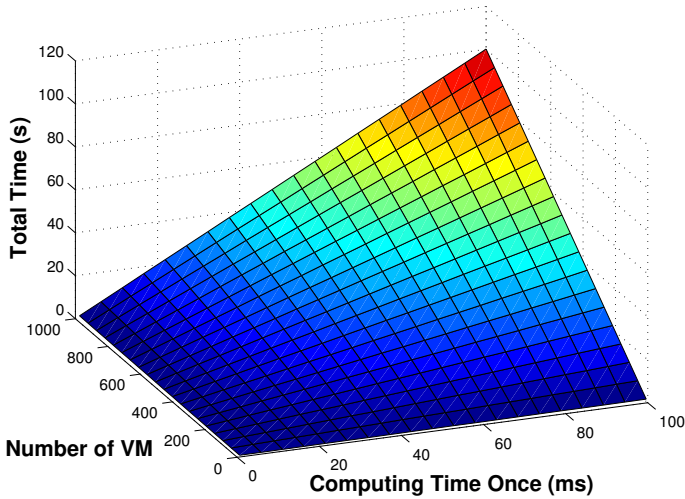

Figure 6. Efficiency comparison

6 CONCLUSIONS

This study has presented an AHP-based decision-making model to assist cloud cluster administrators in evaluating VM migration decisions. The paper investigates the applicability and efficiency of the proposed AHP model by conducting a usability study with 5 VMs usage data and then demonstrating how the model can be applied in a real application. Based on the simulated and experimental results, it can be concluded that the model can facilitate the decision making process and assist administrators to identify all information sources of input data for pair-wise comparisons. The pair-wise comparison procedure is able to capture relative judgments of two elements at once in a trustworthy manner and ensures consistency of these values. The results show that the model has the capability to identify the potential VMs that are stable and need to be migrated. This consolidation of the manner of green cloud computing means that it saves the energy and alleviates the carbon dioxide emissions. Therefore this is a great contribution towards the clean and safe global environment.

Acknowledgements

This work has been supported in part by the Program for Changjiang Scholars and Innovative Research Team in the University No. IRT1078, The Key Program of NSFC – Guangdong Union Foundation No. U1135002, The Fundamental Research Funds for the Central Universities No. JY0900120301.

REFERENCES

- [1] BUYYA, R.—BELOGLAZOV, A.—ABAWAJY, J.: Energy-Efficient Management of Data Center Resources for Cloud Computing: A Vision, Architectural Elements, and Open Challenges. arXiv Preprint arXiv:1006.0308, 2010.
- [2] GONG, L.—XIE, J.—LI, X.—DENG, B.: Study on Energy Saving Strategy and Evaluation Method of Green Cloud Computing System. 8th IEEE Conference on Industrial Electronics and Applications (ICIEA), 2013, pp. 483–488.
- [3] GUAZZONE, M.—ANGLANO, C.—CANONICO, M.: Exploiting VM Migration for the Automated Power and Performance Management of Green Cloud Computing Systems. Energy Efficient Data Centers (E2DC 2012). Springer, Lecture Notes in Computer Science, Vol. 7396, 2012, pp. 81–92, doi: 10.1007/978-3-642-33645-4_8.
- [4] ITURRIAGA, S.—NESMACHNOW, S.—DORRONSORRO, B.—BOUVRY, P.: Energy Efficient Scheduling in Heterogeneous Systems with a Parallel Multiobjective Local Search. Computing and Informatics, Vol. 32, 2013, No. 2, pp. 273–294.
- [5] ZHANG, L.-M.—MA, J.-F.—WANG, Y.-C.—LU, D.: Toward Green Cloud Computing: An Attribute Clustering Based Collaborative Filtering Method for Virtual Machine Migration. Information Technology Journal, Vol. 12, 2013, No. 23, pp. 7275–7279.
- [6] BALIGA, J.—AYRE, R. W. A.—HINTON, K.—TUCKER, R. S.: Green Cloud Computing: Balancing Energy in Processing, Storage, and Transport. Proceedings of the IEEE, Vol. 99, 2011, No. 1, pp. 149–167, doi: 10.1109/JPROC.2010.2060451.
- [7] SAATY, T. L.: Fundamentals of Decision Making and Priority Theory with the Analytic Hierarchy Process. The Analytic Hierarchy Process Series, Vol. 6, Pittsburgh, 1994.
- [8] PARTOVI, F. Y.: Determining What to Benchmark: An Analytic Hierarchy Process Approach. International Journal of Operations and Production Management, Vol. 14, 1994, No. 6, pp. 25–39, doi: 10.1108/01443579410062068.
- [9] JAIN, R.—RAO, B.: Application of AHP Tool for Decision Making of Choice of Technology for Extraction of Anti-Cancer Bioactive Compounds of Plant Origin. International Journal of the Analytic Hierarchy Process, Vol. 5, 2013, No. 1, pp. 3–29, doi: 10.13033/ijahp.v5i1.153.
- [10] UÇAL SARI, I.—ÖZTAYŞI, B.—KAHRAMAN, C.: Fuzzy Analytic Hierarchy Process Using Type-2 Fuzzy Sets: An Application to Warehouse Location Selection. Chapter 12. In: Doumpos, M., Grigoroudis, E. (Eds.): Multicriteria Decision Aid and Artificial Intelligence. John Wiley & Sons, 2013, pp. 285–308.
- [11] CAY, T.—UYAN, M.: Evaluation of Reallocation Criteria in Land Consolidation Studies Using the Analytic Hierarchy Process (AHP). Land Use Policy, Vol. 30, 2013, No. 1, pp. 541–548.
- [12] CHAN, W. W.—YUENG, S.—CHAN, E. S.—LI, D.: Hotel Heat Pump Hot Water Systems: Impact Assessment and Analytic Hierarchy Process. International Journal of Contemporary Hospitality Management, Vol. 25, 2013, No. 3, pp. 428–446.
- [13] POURGHASEMI, H. R.—MORADI, H. R.—FATEMI AGHDA, S. M.: Landslide Susceptibility Mapping by Binary Logistic Regression, Analytical Hierarchy Process, and

- Statistical Index Models and Assessment of Their Performances. *Natural Hazards*, Vol. 69, 2013, No. 1, pp. 749–779, doi: 10.1007/s11069-013-0728-5.
- [14] ROIG-TIERNO, N.—BAVIERA-PUIG, A.—BUIRAGO-VERA, J.—MAS-VERDU, F.: The Retail Site Location Decision Process Using GIS and the Analytical Hierarchy Process. *Applied Geography*, Vol. 40, 2013, pp. 191–198, doi: 10.1016/j.apgeog.2013.03.005.
- [15] BORADE, A. B.—KANNAN, G.—BANSOD, S. V.: Analytical Hierarchy Process-Based Framework for VMI Adoption. *International Journal of Production Research*, Vol. 51, 2013, No. 4, pp. 963–978, doi: 10.1080/00207543.2011.650795.
- [16] ERGU, D.—KOU, G.—PENG, Y.—SHI, Y.—SHI, Y.: The Analytic Hierarchy Process: Task Scheduling and Resource Allocation in Cloud Computing Environment. *The Journal of Supercomputing*, Vol. 64, 2013, No. 3, pp. 835–848.
- [17] GARG, S. K.—VERSTEEG, S.—BUYA, R.: A Framework for Ranking of Cloud Computing Services. *Future Generation Computer Systems*, Vol. 29, 2013, No. 4, pp. 1012–1023.
- [18] HARNISCH, S.—BUXMANN, P.: Evaluating Cloud Services Using Methods of Supplier Selection. *Business Information Systems (BIS 2013)*. Springer, Lecture Notes in Business Information Processing, Vol. 157, 2013, pp. 1–13, doi: 10.1007/978-3-642-38366-3_1.
- [19] WANG, J.—LI, F.—ZHANG, L.: QoS PreferenceAwareness Task Scheduling Based on PSO and AHP Methods. *International Journal of Control and Automation*, Vol. 7, 2014, No. 4, pp. 137–152.
- [20] DE STEIGUER, J. E.—DUBERSTEIN, J.—LOPES, V.: The Analytic Hierarchy Process as a Means for Integrated Watershed Management. In: Renard, K. G. (Ed.): *First Interagency Conference on Research on the Watersheds, 2003*, pp. 736–740.
- [21] FORMAN, E. H.—GASS, S. I.: The Analytic Hierarchy Process – An Exposition. *Operations Research*, Vol. 49, 2001, No. 4, pp. 469–486, doi: 10.1287/opre.49.4.469.11231.
- [22] HAQ, A. N.—KANNAN, G.: Fuzzy Analytical Hierarchy Process for Evaluating and Selecting a Vendor in a Supply Chain Model. *The International Journal of Advanced Manufacturing Technology*, Vol. 29, 2006, No. 7-8, pp. 826–835.
- [23] SAATY, T. L.: How to Make a Decision: The Analytic Hierarchy Process. *European Journal of Operational Research*, Vol. 48, 1990, No. 1, pp. 9–26.
- [24] OSMAN, S. M.—GADALLA, H. M.—ZEANEDEAN, A. R.—RABIE, M. R.: A Compromise Weighted Solution for Multilevel Linear Programming Problems. *International Journal of Engineering Research and Applications*, Vol. 3, 2013, pp. 927–936.
- [25] REISS, C.—WILKES, J.—HELLERSTEIN, J.: Google Cluster-Usage Traces: Format+ Schema. Google Inc., White Paper, 2011.
- [26] LIBERATORE, M. J.—NYDICK, R. L.—SANCHEZ, P. M.: The Evaluation of Research Papers (Or How to Get an Academic Committee to Agree on Something). *Interfaces*, Vol. 22, 1992, No. 2, pp. 92–100, doi: 10.1287/inte.22.2.92.

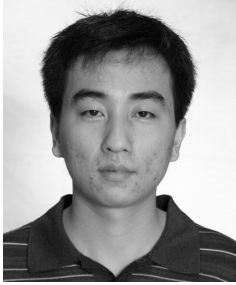

Liumei ZHANG received his B.Eng. in computer science from Air-Force Engineering University, Xi'an, Shaanxi, China, in 2003, and his M.I.T. degree in database management from The School of Information Technology, University of Sydney, Sydney, Australia, in 2007. Currently he is a Ph.D. candidate in computer architecture at Xidian University, Xi'an, Shaanxi, China. His research interests include data mining, wireless sensor networks, and cloud computing.



Jianfeng MA received his B.Sc. degree in mathematics from Shaanxi Normal University, China in 1985, and his M.Eng. and Ph.D. degrees in computer software and communications engineering from Xidian University, China in 1988 and 1995, respectively. From 1999 to 2001, he was with Nanyang Technological University of Singapore as a research fellow. He is an IEEE member and a senior member of Chinese Institute of Electronics (CIE). Currently he is Professor and Ph.D. supervisor in School of Computer Science at Xidian University, Xi'an, China, and the director of the Shaanxi Key Laboratory of Computer Networks and System Security. His current research interests include distributed systems, wireless and mobile computing systems, computer networks, and information and network security. He has published over 150 refereed articles in these areas and coauthored ten books.



Tianshi LIU received his B.Sc. degree from the Northwest University, China in 1982, his M.Eng. degree from Xi'an Jiaotong University, China in 1985, and the Ph.D. degree from Northwestern Polytechnical University, China in 2005. From 1994 to 1995 he was engaged in advanced studies in the Delft University of Technology. From 1985 to 1996, he was with the Institute of Computing Technology of Aviation Industry Corporation. He is a member of China Computer Society. In 2008, he was with School of Computer Science, The University of Birmingham as a research fellow. Currently he is Professor and Master Degree supervisor in School of Computer Science at the Xi'an Shiyou University, Xi'an, China. His current research interests include distributed systems, information system, computer networks, and communication optimization algorithm.



Yichuan WANG received his B.Sc. degree in computer science and technology from the Zhengzhou University of China in 2005, and his M.Sc. degree in computer and its applications from the Chengdu University of Information Technology, China in 2009. Currently he is a Ph.D. candidate with the School of Computer Science and Technology, Xidian University. His research areas include key management and networks security.

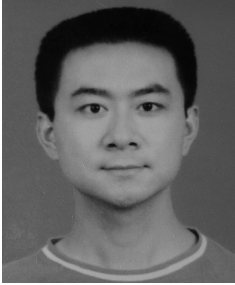

Di LU received his B.Sc. and M.Sc. degrees in computer science and technology from the Xidian University, China in 2006 and 2009, respectively. Currently he is a Ph.D. student in the School of Computer Science and Technology, Xidian University. His research interests include virtualization technology, operating system and storage technology.