

Laser Drilling of Small Holes in Different Kinds of Concrete

Kaori Nagai ^{a*}, Stefan Beckemper ^b, Reinhart Poprawe ^c

^a Associate Professor, PhD, Department of Architecture and Architectural Engineering, Nihon University, Japan.

^b PhD, R & D Laser Technology, Veco B.V., Netherlands.

^c Management Director, PhD, Fraunhofer Institute for Laser Technology ILT, Aachen, Germany.

Received 04 March 2018; Accepted 27 April 2018

Abstract

Recently, in Japan, safety measures such as earthquake-resistant reinforcement work and tile-reinforcement work are increasing. Current concrete drilling methods have issues such as noise, vibration, dust, and reaction force. These methods are causing stress for the residents. Consequently, solutions are being sought for work taking place on skyscrapers and at facilities that cannot shut down during construction, such as hotels, schools, hospitals and geriatric facilities for instance. This study investigated how laser drilling change the conditions, depending on the type of concrete in order to determine the possibility of using laser drilling for tile-reinforcement work and repairing concrete on building exterior. The results confirmed that it's possible to successfully drill holes for drilling diameters of 4 to 6 mm and depths of around 50 mm in concrete with a compressive strength within the range of 20 to 100 N/mm² by adjusting laser conditions. In case of deep holes the CW-mode should be chosen. Furthermore, by controlling laser irradiation conditions, it is possible to change the shape of the holes. These different kinds of holes are suitable for different applications. It is expected that laser irradiation drilling will be applied to new construction methods.

Keywords: Laser Drilling; Various Types of Concrete; Laser Irradiation Condition; Tile-Reinforcement.

1. Introduction

Recently, in Japan, awareness of disaster prevention is rising owing to the Great East Japan earthquake and the Kumamoto earthquake, and earthquake-resistant constructions and tile-reinforcement research are increasing. [1]

For this study, holes are drilled into concrete in order to install anchor bolts and pins. The drilling conditions necessary for reinforcement work are shown in Table 1 [2-4]. Earthquake-resistant constructions need holes with big diameter and depth. That means, big bolts for concrete reinforcement are required. In the case of tile-reinforcement, almost invisible holes and pins with small diameter and depth for fixing and adhesive are necessary. A tile is a thin plate fixed on the exterior surface of a building.

Nowadays the stress for the residents arises during working with standard concrete drills. Therefore, solutions for reducing these problems are required for working performed on skyscrapers and at facilities that must remain open to the residents, such as hotels, schools, hospitals and geriatric facilities for instance.

As countermeasures for these issues, low-noise and low-vibration backwards during working or drilling on the exterior. Concrete drilling technology using lasers to deal with reaction force [4]. But laser technology is rarely implemented in the construction field [5-7] however, it is being used in the manufacturing as drilling [8], cutting [9], welding [10], ablation and additive-manufacturing and microfabrication of medical devices, food industry, metal items,

* Corresponding author: nagai.kaori@nihon-u.ac.jp

 <http://dx.doi.org/10.28991/cej-0309131>

➤ This is an open access article under the CC-BY license (<https://creativecommons.org/licenses/by/4.0/>).

© Authors retain all copyrights.

in examinations and diagnostics for instance [11, 12]. Nowadays, it has been started to research for civil engineering field [13-15].

This study investigates the potential of laser drilling to reduce these stress factors in tile-reinforcement work with the aim of easing construction constraints. This report presents the results obtained from drilling for the purpose of tile-reinforcement under various laser conditions for various types of concrete strength. A comparison of different kinds of concrete regarding compressive strength. The drilling results as a function of defocus distance (DFS) and the different kinds of drilling shapes regarding on different laser irradiation conditions.

Table 1. The drilling conditions necessary for reinforcement work

Method	Drilling diameter (mm)	Drilling depth (mm)
Earthquake-resistant construction	14.5 - 23.5	145 - 245
Tile-reinforcement	5 - 7	55 - 75

2. Current Technologies and Research Objectives

2.1. Tile-Reinforcement Drilling

Tile-reinforcement is a method of repairing that involves drilling into a tile as well as into a concrete building structure and reinforcing the tile by inserting four anchor pins per square meter and injecting an adhesive.

Currently, in tile-reinforcement work, concrete drill diameters are set from 5 to 7 mm, and drilling is performed using low-noise and low-vibration drills [3]. Reaction force is necessary during concrete drilling, and noise is at 80 dB level, which is low compared to vibrating drills and churn drills but makes conversation difficult [16, 17].

2.2. Research Objectives

In this study, concrete drilling diameters were targeted at approximately 4 to 6 mm used to get no effect to the exterior appearance. The typical concrete used in these experiments have a strength of 20 to 50 N/mm². Variations of drilling conditions, laser power, irradiation time, defocusing distance and different laser modes were applied for different kinds of concrete, to get the best laser parameters for tile-reinforcing drilling.

3. Methodology

3.1. Experiment Items

Experiments were carried out on the following two items:

Experiment 1: Measurement of drilling depth depending on the laser mode.

Experiment 2: Relationship between drilling depth and drilling shape for each type of concrete.

3.2. Concrete Specimen

The concrete specimens used in each experiment are shown in Table 2. A concrete made from several composites, cement, sand, stone and some admixtures. The concrete strength is changed depending on mix proportion. The 20 N/mm² (type 20 N) is using much cement and sand. However, in the case of the 100 N/mm² (type 100 N), is using much stone compare the other strength. The specimen dimensions were 100×100×100 mm³.

Table 2. Concrete specimen

Experiment No.	Concrete compressive strength (N/mm ²)
1	20, 35, 50
2	35, 100

3.3. Laser

The experiments were carried out with a Nd:YAG laser ($\lambda=1064$ nm), because of Nd:YAG lasers are more suitable than CO₂ lasers for use in the construction field. Laser irradiation conditions are shown in Table 3. The laser irradiation schematic diagram is shown in Figure 1. In order to drill into concrete using a 10 kW Nd:YAG laser, the laser's focal point was placed on the surface of the concrete specimens, and the defocus distance (DFS) was set into positive direction. Two different laser modes were used in these experiments: pulse mode (P-mode) and continuous wave mode (CW-mode). P-mode conditions are: pulse length=50 ns, repetition rate =10 Hz. Experimental drilling diameters were 4 to 6 mm, and the DFS had a range of 10 to 110 mm. Each examination was repeated five times for each experiment condition.

Table 3. The laser irradiation conditions

Experiment No.	Laser power (kW)	Irradiation mode	DFS (mm)	Irradiation time (s)
1	1	P-mode, CW-mode	40	3, 5, 10, and 15
2	1, 3, 5 and 10	CW-mode	10 - 110	3, 5, 10 and 15

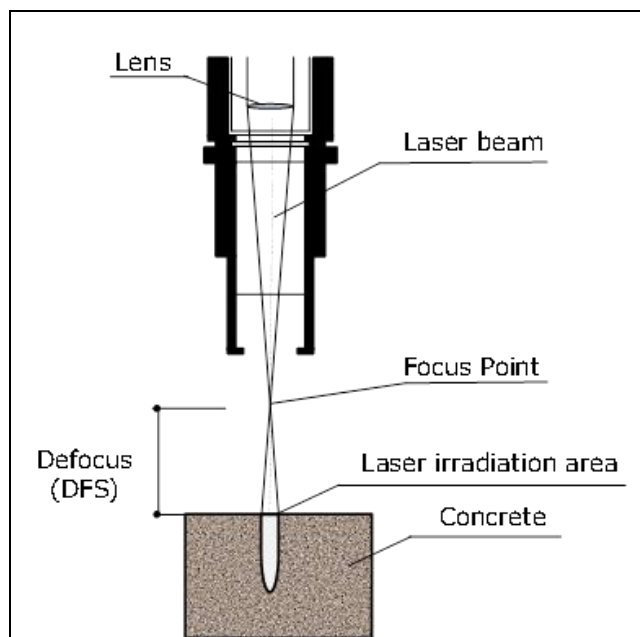

Figure 1. Schematic Diagram of Laser Irradiation

4. Results of Experiment 1

4.1. Concrete Compressive-Strength Comparison

Figure 2 shows the concrete compressive strength and drilling depth range for each laser mode. The overall trend for both P-mode and CW-mode was that drilling depths were deeper for concrete with more compressive strength. With CW-mode, the average drilling depth increased as the concrete compressive strength increased.

It is a fact that as the compressive strength increases, the concrete density also increases. There was also a tendency towards a wider variation in drilling depth.

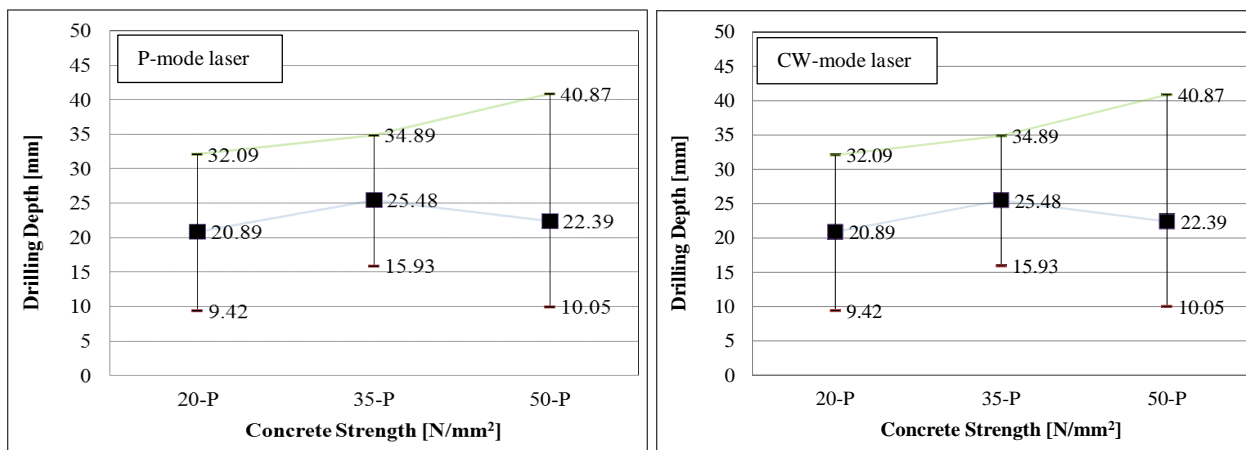

Figure 2. Comparison of the drilling depth as a function of different kinds of concrete for the P-mode and the CW-mode

4.2. Laser Mode

Figures 3 and 4, respectively, the dependency between drilling diameter and depth of the holes showed that for every laser mode, the diameter and the depth of the holes increased. However, that tendency was not observed in the type 20 N to type 35 N range regarding CW-mode.

Furthermore, comparing the drilling depth of each mode, the CW-mode shows deeper holes than the P-mode. This

may be because the CW-mode has a larger heat affected zone (HAZ) on a concrete surface. In the case of CW-mode, the concrete type 20 N shows different characteristic in material, compared to the concrete type 50 N. The interaction of laser irradiation in type 20 N is bigger than in type 50 N. The HAZ in type 20 N is larger than in type 50 N. This leads to bigger diameter in type 20 N, but it doesn't lead to deeper holes.

Because the amount of dross in the type 20 N is larger than the amount of dross in types with higher strength. The higher amount of sand and cement in type 20 N leads to a bigger amount of dross.

This black dross leads to higher absorption of the laser irradiation and therefore to a reduction of drilling depth.

In the case of P-mode, the maximum depth in both materials is lower than the maximum depth of CW-mode. Because the applied energy is lower than in the CW-mode.

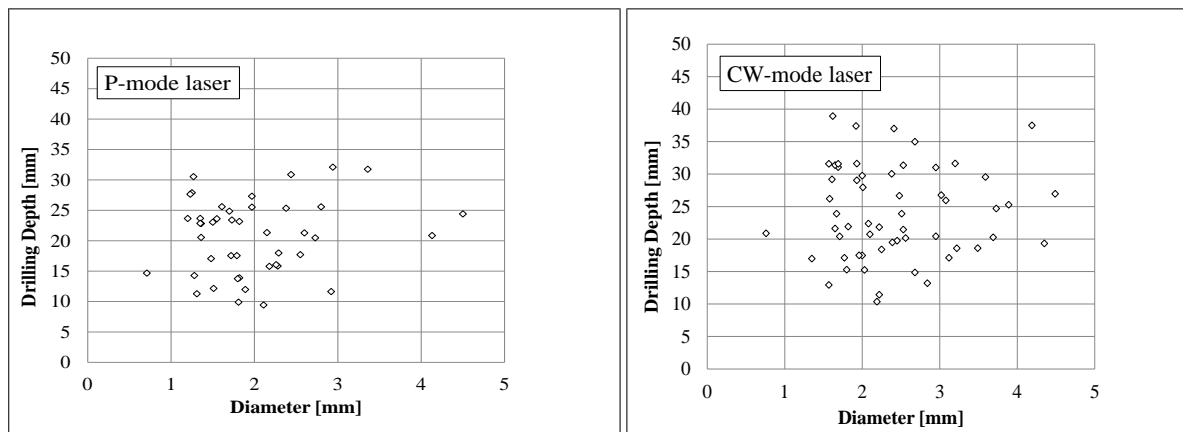

Figure 3. Drilling depth as a function of diameter for each laser mode (Type 20 N)

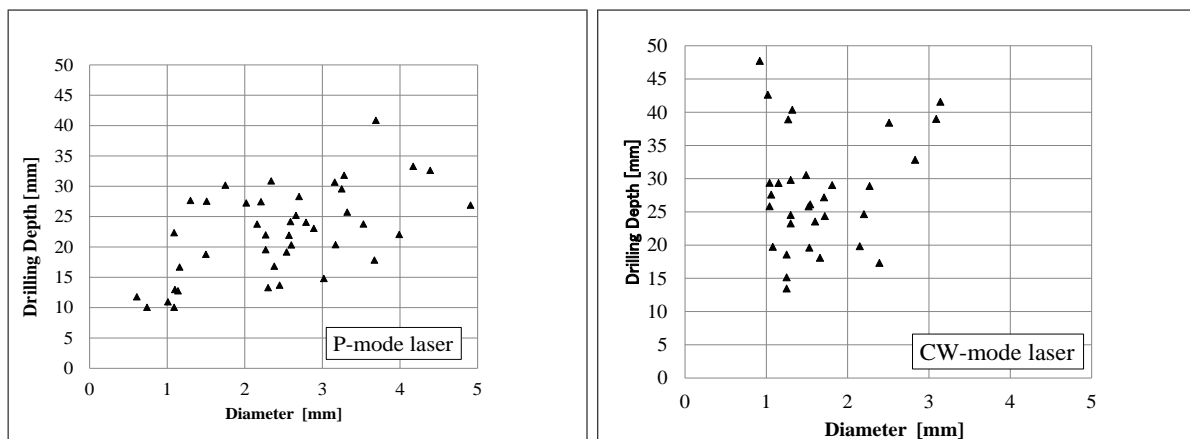

Figure 4. Drilling depth as a function of diameter for each laser mode, (Type 50 N)

5. Experiment 2: Results of General Concrete

5.1. The Drilling Depth as a Function of the DFS

Figure 5 shows the relationship between DFS and drilling depth for a laser irradiation time of 5s (35 N/mm²). For each laser output, as the DFS value increased, there was a tendency for the drilling depth to decrease; this is because the laser's power density on a drilling surface decreases with larger DFS values. For outputs of 1 and 3 kW, drilling depth decreased by about 70% between DFS values of +10 to +40 mm; however, for DFS values of +80 to +110 mm, the drilling depth was uniform at 2 to 3 mm.

This may have occurred because even though the drilling diameter increased with higher DFS values owing to the lower power density radiating to the surface of the concrete, drilling depths were smaller because of the surface dross formation inside the hole. However, for 5 kW, even DFS values of +80 to 110 mm had drilling depths of 5 mm, and we confirmed that if the laser power is 5 kW, drilling is possible.

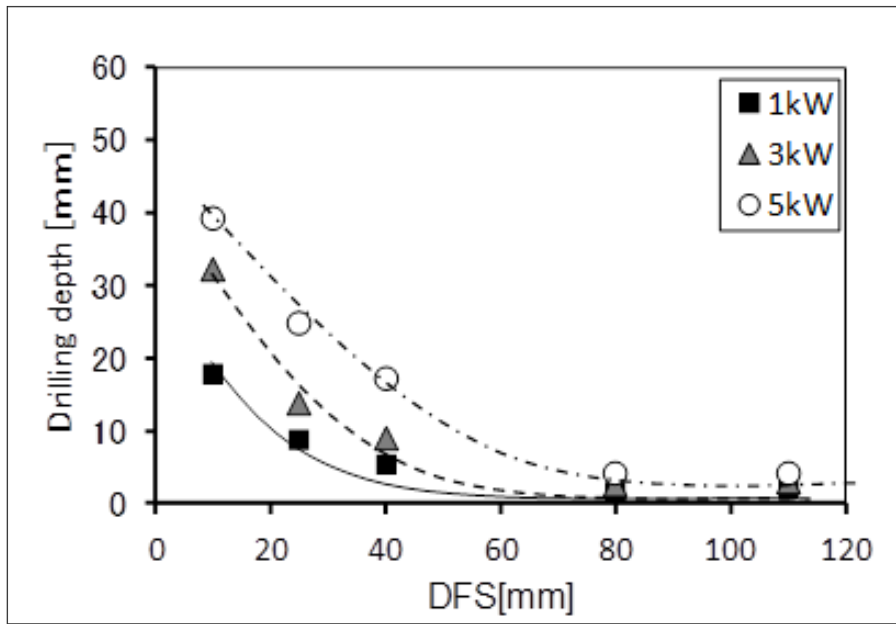

Figure 5. Drilling depth as a function of the DFS (Type 35 N, 5s) for an irradiation time 5s and different laser power



5.2. Drilling Shape and Depth

Table 4 shows the different drilling shapes. After analyzing the cross-sections of the drillings, conducted for each experimental condition, the shapes could be classified into four types.

Figure 6 shows the changes in drilling shape depending on changes in drilling diameter and depth. Drilling depths in the 8 to 22 mm range were categorized as Shape A, those in the 17 to 32 mm range as Shape B, and those in the 30 to 58 mm range as Shape C.

Shape A is a cross-section of the shape of the laser beam itself with relatively low laser power and short irradiation times. Shape B is a result of the concrete absorbing with more laser power and short irradiation time. Shape C results from a higher power, and longer irradiation time. Because of the short DFS and relatively high density the reflection of the laser beam inside the holes lead to this shape C. Shape D was limited to a range of 4 to 6 mm in diameter and 30 to 34 mm in depths. It is assumed that it was affected by the reflection of laser beam inside the hole comparable to shape C. The Type 35 N has a bigger proportion of cement and sand. The probability to drill into cement and sand is higher. That leads to the shape D.

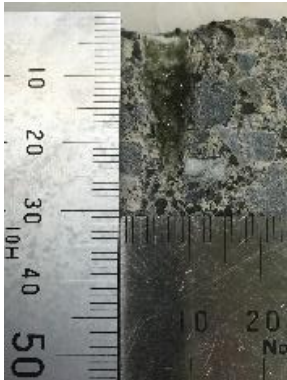
Table 4. The drilling shapes

Drilling shape A		Drilling shape B	
			
	Form of V		Form of U
Drilling shape C		Drilling shape D	

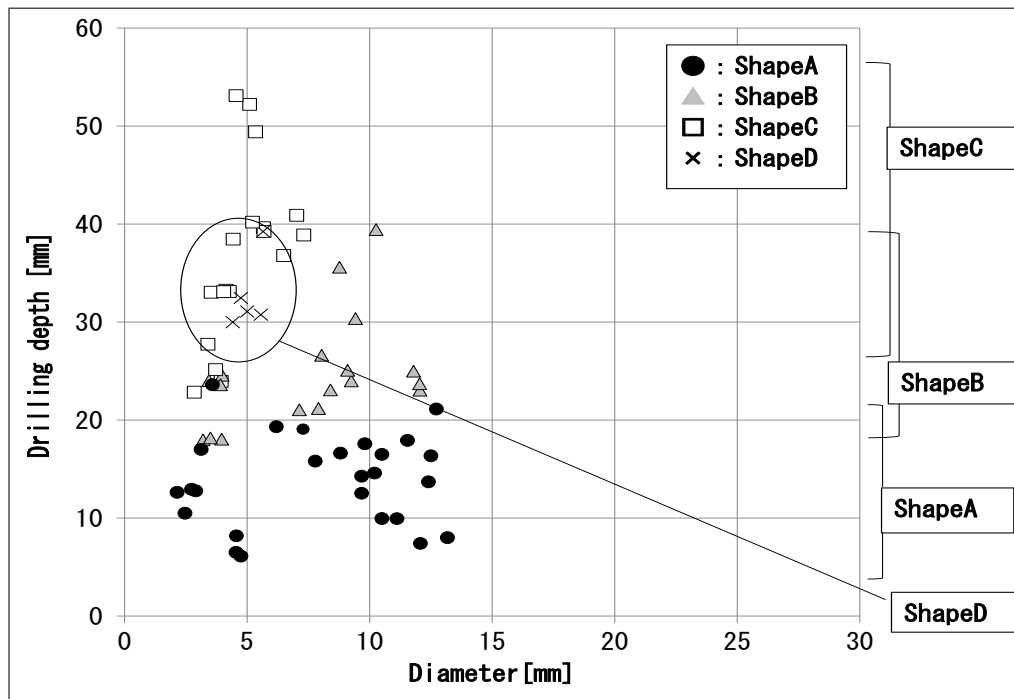
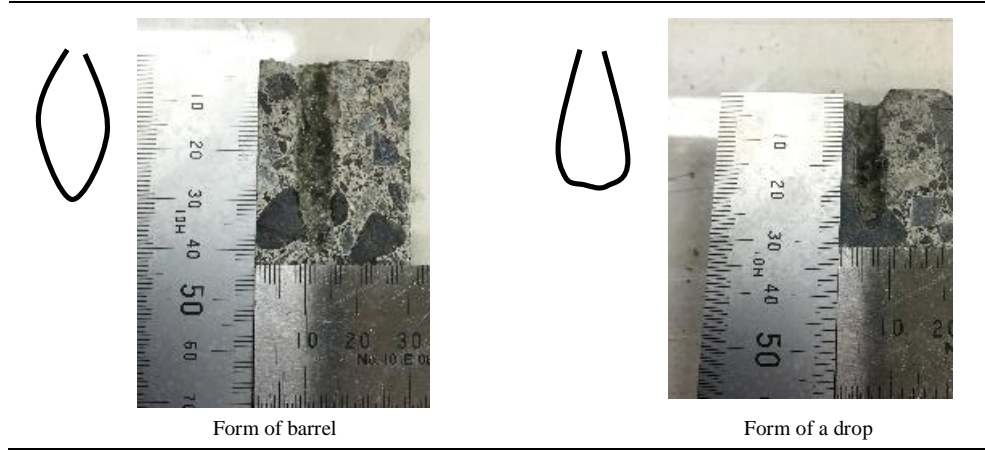

Figure 6. Drilling shapes and depths as the function of the diameters (Type 35N)

5.3 Drilling Shape Changes with Regards to DFS

Figure 7 shows the proportion of drilling shapes for different DFS. There is a tendency for a larger number of shape A, as a result of increasing of DFS, and therefore decreasing of the laser density.

Furthermore, shape C and D were only observed for a $DFS \leq 10$ mm. Due to this condition a $DFS \leq 10$ mm generated the smallest drilling diameter with the greatest laser power density in this study.

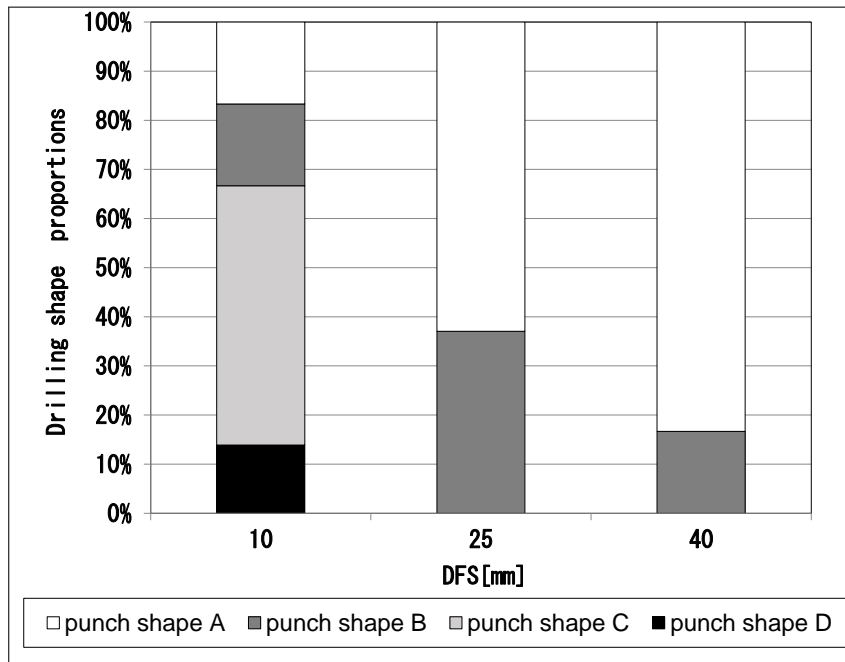

Figure 7. The proportion of drilling shapes as a function of DFS (Type 35 N)

6. Experiment 2: Results of Ultra High Strength Concrete

6.1. The Drilling Depth as a Function of the DFS

Figures 8 and 9 show the drilling depth as a function of the DFS for laser irradiation times of 5 and 10s on ultra-high strength concrete of type 100 N. For ultra-high strength concrete and other strengths concrete the drilling depth decreases, for all laser power by increasing the DFS. Comparing figure 8 with the 10s irradiation results of Figure 9 the maximum drilling depth is identical for 5 kW. However compared with the 10s irradiation results of Figure 9, the maximum drilling depth is identical for 5 kW. When the drilling diameter is larger, the drilling depth is greater.

Presumably, because the aggregate content inside the concrete differs depending on strength. The drilling depth and range of the heat effect changes, depending on the laser conditions.

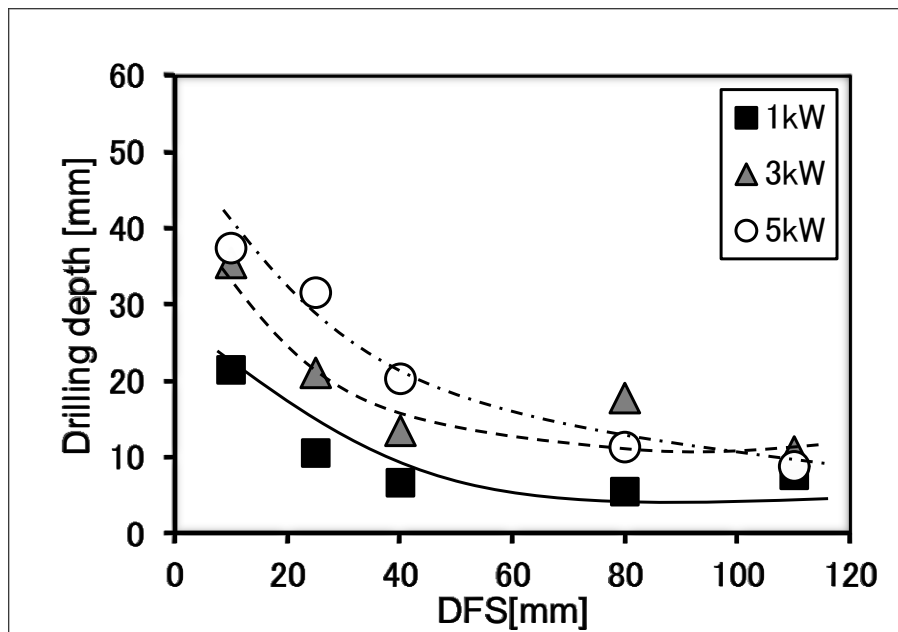

Figure 8. Drilling depth as a function of the DFS for an irradiation time of 5s and different laser power (Type 100 N)

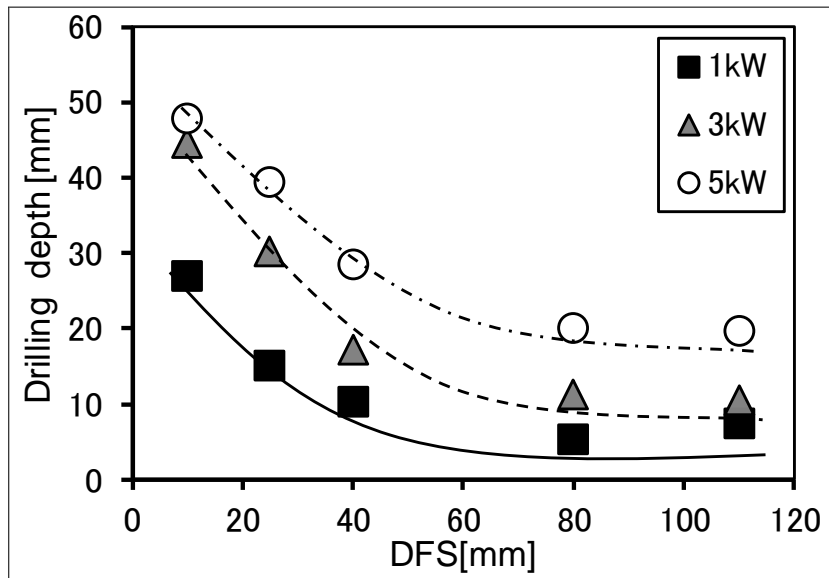

Figure 9. Drilling depth as a function of the DFS for an irradiation time of 10s and different laser power (Type 100N)

6.2. Drilling Shape and Depth

Figure 10 shows the drilling shape and the drilling depth as a function of the diameter. As with other strengths of concrete, ultra-high strength concrete of type 100 N showed shape A in the range of 4 to 20 mm drilling depth. Shape B in the range of 18 to 38 mm, and shape C in the range of 30 to 52 mm. However, in the range of 1 to 5 kW, shape D was not observed in concrete of type 100 N at all. It is assumed that a greater power density is needed to obtain this shape D.

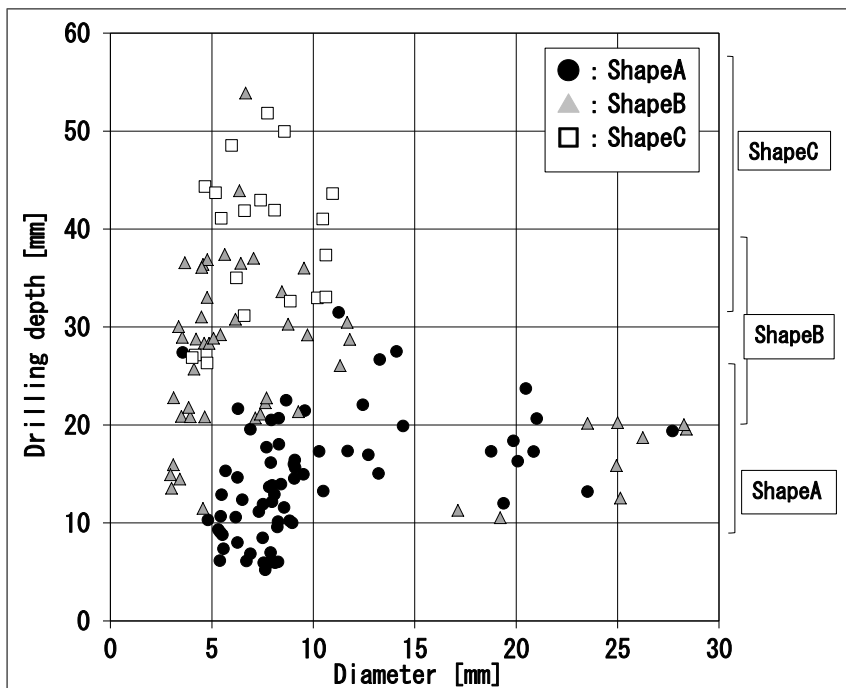

Figure 10. Drilling shapes and depths as a function of the diameters (100 N)

6.3. Drilling Shape changes with Regards to DFS

Figure 11 shows the proportion of drilling shapes as a function of DFS. There is a greater tendency for shape A and shape B by increasing the DFS values, presumably because as the DFS values increase, laser power density decreases, and thereby causing lower drilling depths. Furthermore, when DFS is 10 to 40 mm, the resulting drilling shape is shape C. Conceivably, because of the laser power and irradiation time, the laser power density is too low reaching the range of 30 to 52 mm.

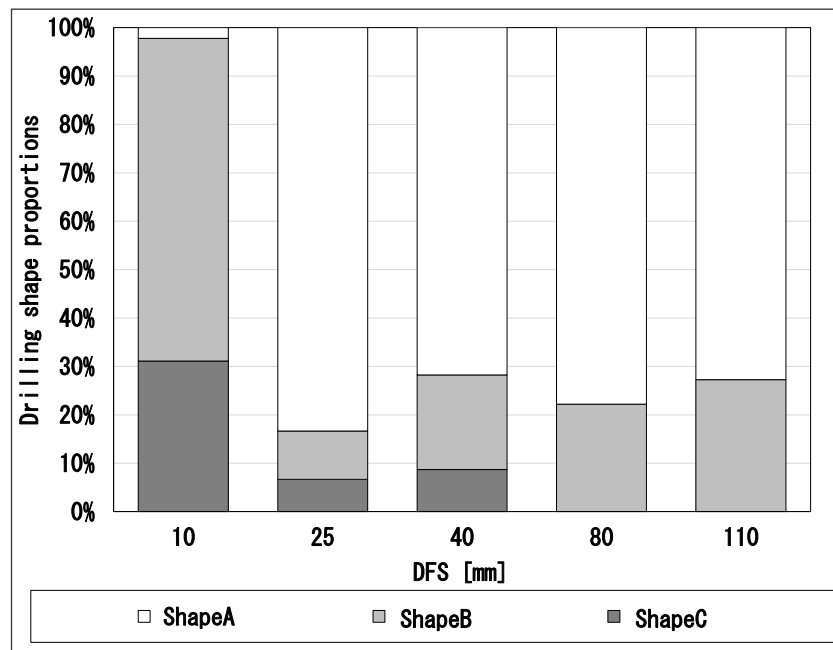

Figure 11. The proportion of drilling shapes as a function of DFS (Type of 100 N)

7. Conclusion

- It is possible to generate holes in a range of 4 to 6 mm diameter, and around 50 mm depth with appropriate laser settings.
- The shapes of drilling can be classified into 4 types. The types depend on the laser conditions.
- By using 5 kW laser power and a small drilling diameter, the drilling depths increases; however, it confirmed that it is difficult to obtain greater drilling depths more than 50 mm because of dross and other effects.
- Regarding to the two different laser modes, the results can't be compared directly. Because of the totally used energy is different.
- And the heat affected zone using CW-mode is longer than the heat affected zone in the plus mode by using the same parameters setting. Furthermore, with this mode it is possible to generate all different shapes.

Regarding to these results, the laser drilling method for work that requires low vibration, low noise and no reaction force can be applied. That means the method will become an effective drilling technology in the future. Furthermore, because it is possible to select different drilling shapes by adjusting the laser parameters. This method will also be applied to new reinforcement construction methods.

8. Acknowledgements

The authors gratefully acknowledge Professor Isamu Matsui, Naoto Okeya, Takeru Hasegawa, Arisa Shimoda in Nihon University and Tim Biermann in Fraunhofer Institute of Laser Technology for their helpful suggestions.

9. References

- [1] Masaya Hirose "Present Condition of Seismic Retrofit of Buildings in Japan" Concrete Journal 35(10), (1997), 3-8, doi:10.3151/coj1975.35.10.10_3.
- [2] H. Nasu, T. Hasegawa, N. Mishima, S. Hatanaka, "Fundamental Study on Reinforcing Effect of Impregnating and Film Forming Agent on Prevention of Falling of Exterior Tiles" Proceedings of Tokai Chapter Architectural Research Meeting (52), (February 2014), 61-64.
- [3] Saitou, H. Trends in consideration of safety and tilework: (General) Technical trends on wall preventive measures. General building renovation and renewal technology magazine. Tetuadou shuppan. pp.38-40, 2008.
- [4] Japan pinnet association, Trends in consideration of safety and tilework: (General) Technical trends on wall preventive measures. General building renovation and renewal technology magazine. Tetuadou shuppan. pp.41-44, 2008.
- [5] H. Daido, T. Yamada, A. Nishimura, "Experimental characterization of concrete removal by high-power quasicontinuous wave fiber laser irradiation", Journal of Laser Applications 29, 041501(2017), doi:10.2351/1.5008326.
- [6] Kaori Nagai, "Laser Processing for Construction Site: Laser Non-Slip Processing" The Laser Society of Japan 38(10), (October

2010), 744-748.

- [7] Laser society of Japan. "Handbook of laser processing applications." (April25 2005):157190. doi:10.1541/ieejeiss.123.241.
- [8] J. O. Maclean, J.R. Hodson, K.T. Voisey, "Laser drilling of via micro-holes in single-crystal semiconductor substrates using a 1070nm fibre laser with millisecond pulse widths", Proceedings of Laser Applications Symposium, (2015), doi:10.1117/12.2175898.
- [9] D. Krajcarz, "Coparison Metal WaterJet Cutting with Laser and Plasma Cuttin", Procedia Engineering69, (2014), 838-848, doi:10.1016/j.proeng.2014.03.061.
- [10]M.Rossini, P. R. Spena, L.Cortese, P.Matteis, D. Firrao, "Investigation on dissimilar laser welding of advanced high strength steel sheets for the automotive industry, Materials Science and Engineering: A628(25),(March 2015), 288-296, doi:10.1016/j.msea.2015.01.037.
- [11] A. Kruusing, "Underwater and water-assisted laser processing: part2 Etching, cutting and rarely used methods", Optics and Lasers engineering 41. (February 2004):329-352. doi:10.1016/S0143-8166(02)00143-4.
- [12] D. He, S. Zheng, J. Pu, G. Zhang, L. Hu, "Improving tribological properties of titanium alloys by combining laser surface texturing and diamond-like carbon film", Tribology International82,PartA(February 2015), 20-27, doi:10.1016/j.triboint.2014.09.017.
- [13] J.Chen, Z.Zhang, X.Chen, C. Zhang, G. Zhang, Z. Xu, "Design and manufacture of customized dental implants by using reverse engineering and selective laser melting technology", The journal of prosthetic dentistry112, Issue5, 1088-1095, (November 2014), doi:10.1016/j.prosdent.2014.04.026.
- [14] Ahmed Hafez, S. Ibrahim, S. Omar, S. Eddeen, K. Beshay, "Laser Drilling Using Nd:YAG on Limestone, Sandstone and Shale Samples: ROP Estimation and the Development of a Consrant ROP Drilling System", Proceedings of the SPE North Africa Technical 2015, SPE-175848-MS, doi:10.2118/175848-MS.
- [15] A.Bharatish, B.Kishore Kumar, R.Rajath, H.N.Narasimha Murthy, "Investigation of effect of CO2 laser parameters on drilling characteristics of rocks encountered during mining", Journal of King Saud University-Engineering Sciences, (December2017), doi:10.1016/j.jksues.2017.12.003.
- [16] H. Hitoshi, "On site experiment for evaluation of the noise and vibration applying lower noise and vibration type drill: Part2 Result of the measurement of vibration." Japan society for finishings technology (October 2006): 183-186.doi:10.14820/finex.2006.0.45.0.
- [17] Yoshinobu Yokote. "Low-noise type drilling noise and vibration: Comparison of propagation characteristics in the population and the traditional hammer drill." Reform (July 2004), 45-47, doi:10.18948/shasetaikai.2004.3.0_1779.