

Design of Freeform  
Membrane-Tensegrity Structure

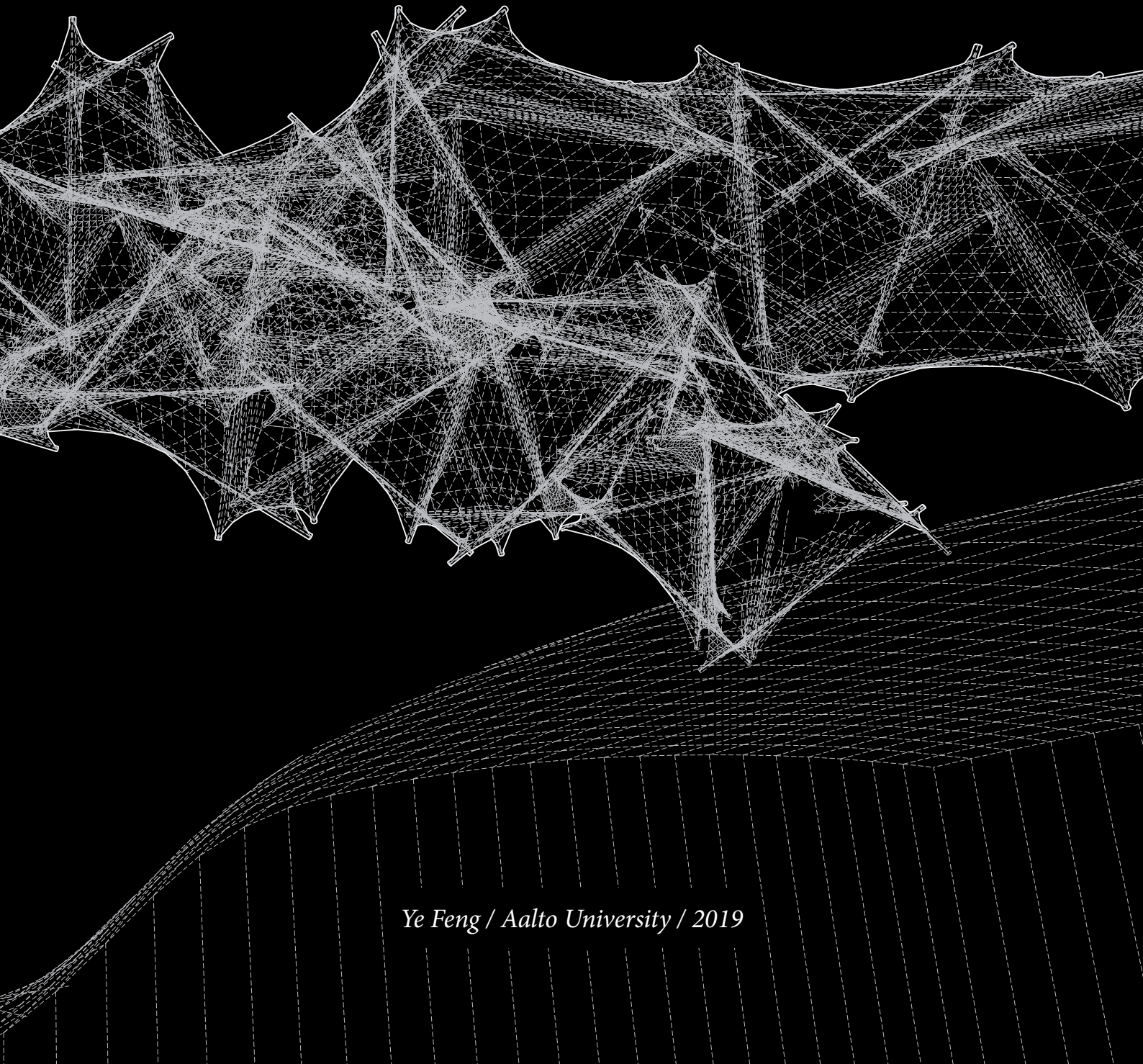

*Ye Feng / Aalto University / 2019*



## ABSTRACT

Inspired by a lightweight, and tectonically decent pavilion, MOOM pavilion in Japan, this thesis study explores a digital approach to transform an existing physical structure into a digital computational model by following the principle behind in order to explore and generalize the principle behind and develop a generic digital tool for designing freeform membrane-tensegrity structures in architecture.

Through generalize the regulations behind the existing structure and the generic digital tool development, the way of designing the same type of structure could be more efficient, logical and free.

In this thesis, a generic digital tool for constructing membrane-tensegrity structure will be developed by referring to the analysis of MOOM pavilion and the generic freeform tensegrity algorithm proposed by Tomohiro Tachi and his team in The University of Tokyo. Through analysis and tool development process, the digital modeling and simulation programs are required. Here the used programs are Rhinoceros 6; Rhinoceros plug-in Grasshopper and Kangaroo Physics; Kangaroo 2; Weaverbird etc. in grasshopper.

Furthermore, two conceptual designs of freeform membrane-tensegrity structures would be proposed as two possible approaches to apply the developed digital tool in architectural and structural design. Since then, this thesis study will be an inspiring starting point for the further researches and designs of membrane-tensegrity structures.

*Author:* Ye Feng  
*Title of thesis:* Design of Freeform Membrane-Tensegrity Structure  
  
*School:* Aalto University School of Arts, Design and Architecture  
*Department:* Department of Architecture  
*Degree programme:* Master of Science in Architecture  
  
*Supervisor:* Prof. Dr. Toni Kotnik  
*Advisors:* Prof. Dr. Toni Kotnik  
  
*Year:* 2019  
*Number of pages:* 100  
*Language:* English

# CONTENTS

<b>Abstract</b>	05		
<b>Chapter I. Case study and analysis - MOOM pavilion</b>	10	<b>Chapter IV. Digital speculations of membrane-tensegrity structures</b>	50
1. Introduction of MOOM pavilion and its characteristics.	10	1. Systematic and continuous design of membrane-tensegrity.	50
2. Concept and structure of MOOM pavilion.	12	2. Modular geometry repetition.	52
3. Structure type of MOOM pavilion and its abstract models.	14	3. Structural speculation of a membrane-tensegrity bridge.	56
		4. Surface manipulation.	66
		5. Structural speculation of a membrane-tensegrity pavilion.	69
<b>Chapter II. Membrane-tensegrity</b>	18		
1. Tensegrity as a natural structure.	18	<b>Conclusion</b>	80
2. History of tensegrity and its classical models.	21		
3. Membrane and membrane-tensegrity structure.	25	<b>Appendix</b>	86
<b>Chapter III. Generic digital tool for designing freeform membrane-tensegrity structure</b>	30	<b>Figure reference</b>	94
1. Digital tools and experiments for tensegrity simulation.	30		
2. Algorithm for constructing freeform tensegrity in theory and the development of a digital tool based on the algorithm.	34	<b>Bibliography</b>	96
3. Generic algorithm of freeform membrane-tensegrity.	41		
4. Optional geometric constrains for designs.	46	<b>Acknowledgment</b>	99

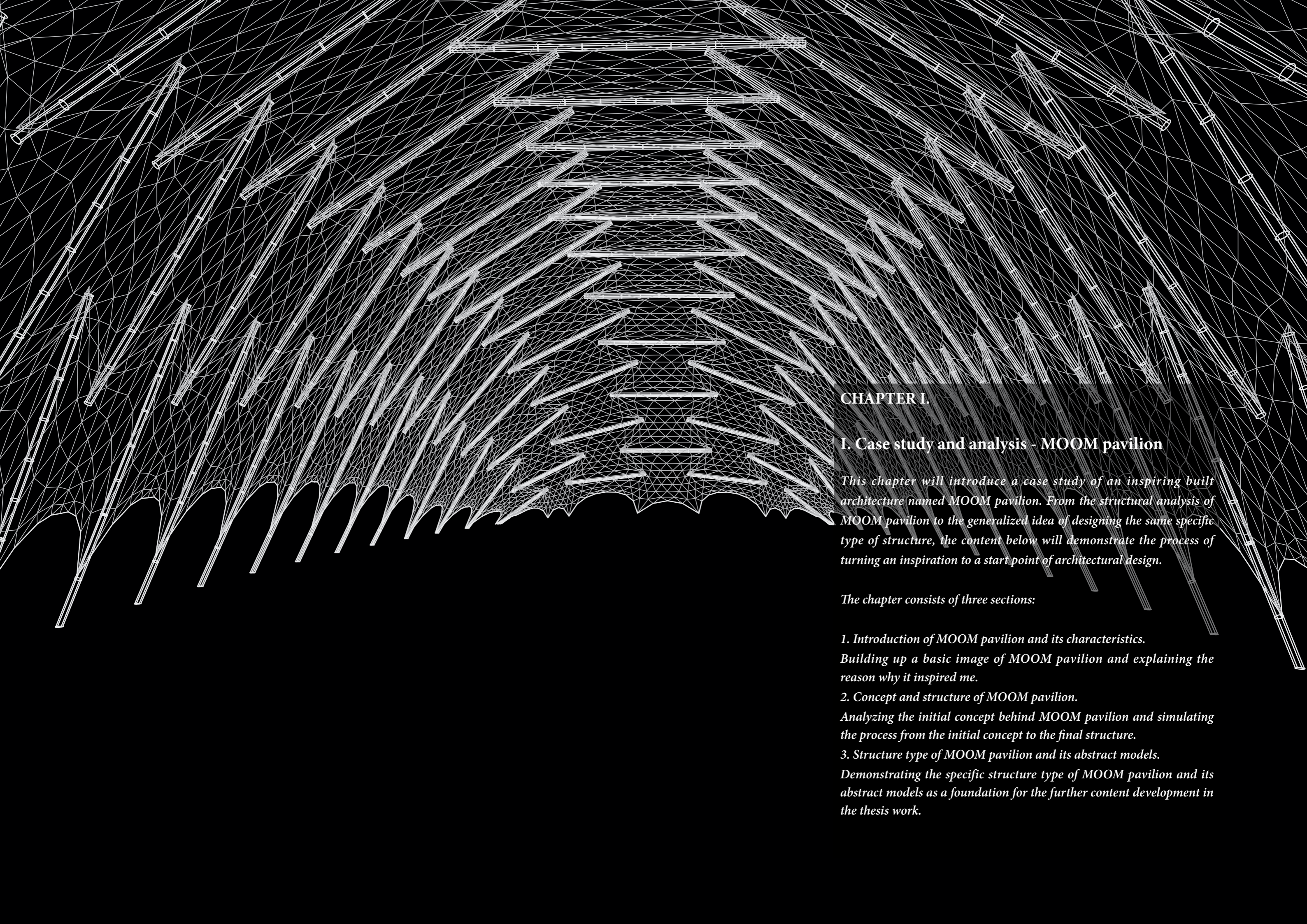

## CHAPTER I.

### I. Case study and analysis - MOOM pavilion

*This chapter will introduce a case study of an inspiring built architecture named MOOM pavilion. From the structural analysis of MOOM pavilion to the generalized idea of designing the same specific type of structure, the content below will demonstrate the process of turning an inspiration to a start point of architectural design.*

*The chapter consists of three sections:*

*1. Introduction of MOOM pavilion and its characteristics.*

*Building up a basic image of MOOM pavilion and explaining the reason why it inspired me.*

*2. Concept and structure of MOOM pavilion.*

*Analyzing the initial concept behind MOOM pavilion and simulating the process from the initial concept to the final structure.*

*3. Structure type of MOOM pavilion and its abstract models.*

*Demonstrating the specific structure type of MOOM pavilion and its abstract models as a foundation for the further content development in the thesis work.*

## I. Case study and analysis - MOOM pavilion

### 1. Introduction of MOOM pavilion and its characteristics.

MOOM pavilion is an experimental temporary pavilion designed by one of the partners of C+A coelacanth and associates, Kazuhiro Kojima, and was built in 2011 in Tokyo. The pureness and beauty of architectural tectonic have been performed well in the pavilion. From the photos (*Fig. 01; Fig. 02.*) illustrated below, the whole architecture look like a decent whole piece of cloud floating above the ground. And it is clear that there are just two functional elements which formed the whole architecture. One is a single layer of fabric that covers the whole space and encloses the pavilion from exterior environment, while allows sunlight to come through. Another functional element is a system of rigid sticks that support the whole piece of fabric above and shape the form of the pavilion.

Therefore, MOOM pavilion is unique and inspiring in the way that, traditional buildings mostly have the structure and the facade as two separate elements, while in MOOM pavilion, the structure and its facade behave as one element. The structure is the architecture.

Besides, unlike the conventional way of constructing architecture, piling huge amount of solid materials to form space and stabilize the structure, the structure of MOOM pavilion seems extremely light-weight with only two structural elements efficiently forming the overall structural shape, as well as reaching a specific spatial quality. Looking closer into the pictures, the way that all the sticks accommodate in the whole structure is special since they are totally separate from each other. In this way, MOOM pavilion differentiates with the most commonly used column and beam system structures, where the compression-bearing elements are always connected with each other to share the load from above. From the interior photo, it is clear that there is a specific coded pattern proposed from the beginning of design, and a clear structural principle which leads the way of composing the two structural elements correctly and efficiently. In comparison, the uniqueness of MOOM pavilion in the way of force efficiency and tectonic aesthetic triggers my deep interests and guides me to the further researches.



*Fig. 01.  
Exterior photo of  
MOOM pavilion from  
C+A coelacanth and  
associates official website.*



*Fig. 02.  
Interior photo of MOOM  
pavilion from C+A  
coelacanth and associates  
official website.*

## 2. Concept and structure of MOOM pavilion.

The initial motivation behind MOOM pavilion is based on a type of origami pattern named Waterbomb tessellation. The pictures (Fig. 03; Fig. 04.) illustrate an example of Waterbomb tessellation origami in 2 dimensional plan and 3 dimensional space. The pattern of Waterbomb tessellation inspired Kojima, thus he kept the same pattern as well as the Origami form as the initial geometrical shape for MOOM pavilion as shown in the pictures on the next page (Fig. 05; Fig. 06.). The last picture at the bottom illustrates the simulation of the final geometric form of MOOM pavilion based on the spatial Origami pattern.

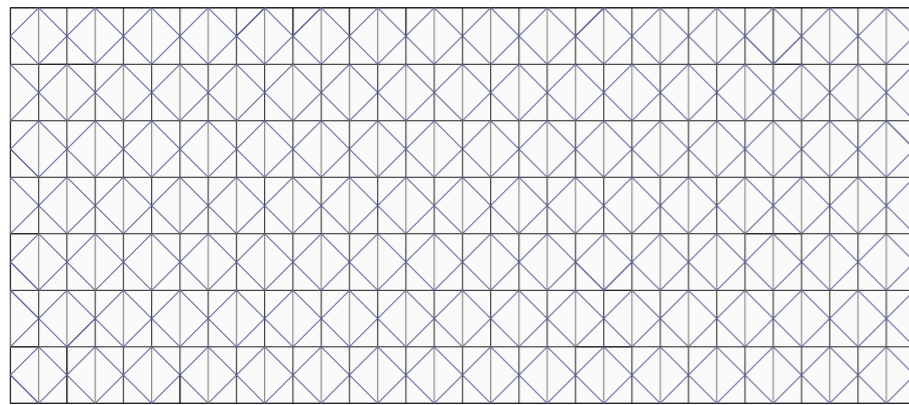

Fig. 03.  
2D planar pattern of  
Waterbomb tessellation  
origami

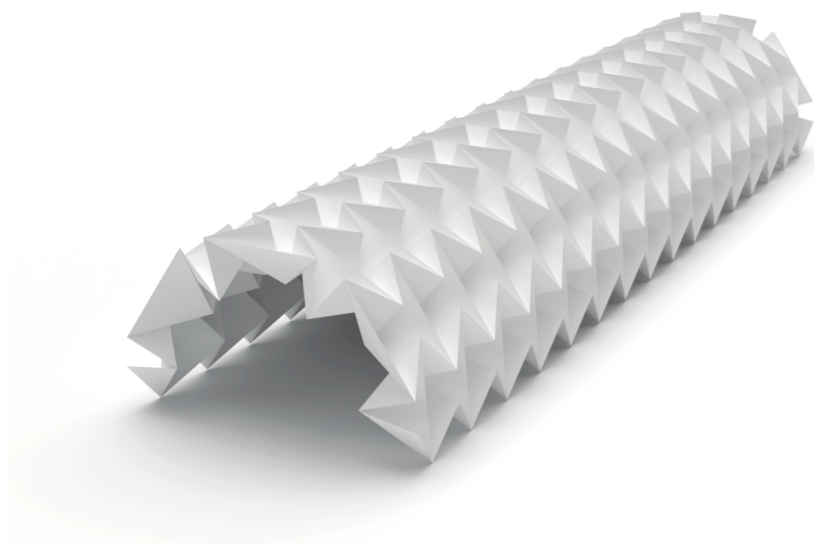

Fig. 04.  
3D spatial pattern of  
Waterbomb tessellation  
origami

By exploring the 3 dimensional Origami model, one specific pattern can be regulated that the peak edges which are colored in black in the diagram (Fig. 05) are always staggered and spacing out with each other while the red lines underneath the peak edges always constrain the peak edges in the correct positions. In the meanwhile, the red lines always go continuously without any breaks. In this way, the spatial pattern of MOOM pavilion could be abstracted into a strut-cable network as shown in the diagram. Compare with the final image of MOOM pavilion, it is clear that the Origami pattern has not been transformed topologically.

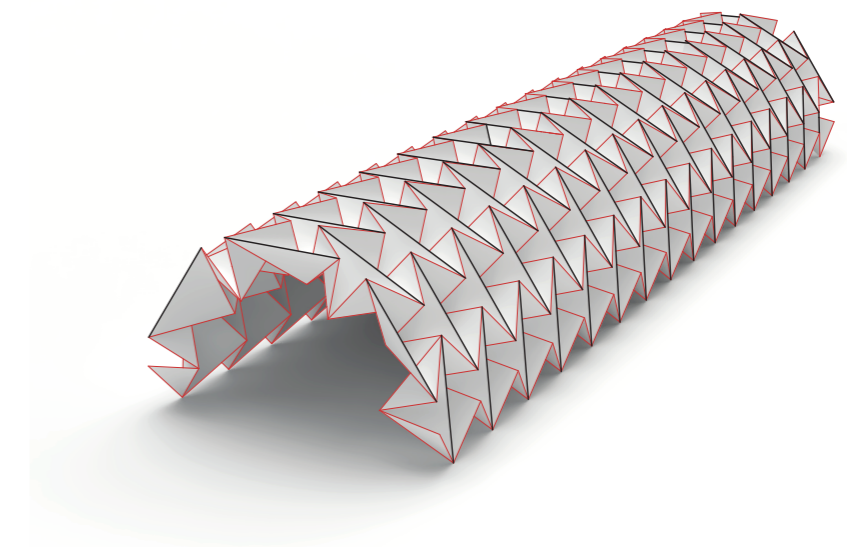

Fig. 05.  
Abstract 3D spatial  
pattern of Waterbomb  
tessellation origami



Fig. 06.  
Simulation of the  
final geometry form of  
MOOM pavilion

### 3. Structure type of MOOM pavilion and its abstract models.

Therefore, it is clear that the structure of MOOM pavilion is purely formed by two types of force elements, which are the rigid independent compression elements and the elastic continuous tension elements. Both of the elements tend to balance the forces of tension and compression by deforming and repositioning themselves, after which the system will reach a self-equilibrium state and the overall structure will be stabilized.

Thus, the structural principle of MOOM pavilion could be generalized as “Tensegrity” termed by Buckminster Fuller or “floating compression” termed by Kenneth Snelson. However, in the case of MOOM pavilion, there are both systems presented: the tensegrity system is visible in the main tension lines which are highly tensioned, and are almost linear fold in the fabric between the compression elements. The membrane, thus, could be regarded as continuously smoothing out of tension forces with main concentration along the mentioned fold tension lines. Therefore, an elastic membrane cooperates with the regulated and independent rigid struts together formed an extremely lightweight and successful experimental project: MOOM pavilion.

In conclusion, the spatial pattern of Waterbomb tessellation origami leads the way to build an initial geometric form for MOOM pavilion, and the rule of tensegrity bridges the method for the eventual self-equilibrium form-finding process. Creatively, Kojima substitutes the visible elastic tensional cables with an elastic membrane, so that the pavilion presents more clearly the beauty of tensegrity tectonic. 131 separated aluminum bars are “floating” in the ocean of white polymer membrane, MOOM pavilion successfully announces its identity as the world first membrane structure that cooperated with the tensegrity principle, which in this thesis I term it “membrane-tensegrity”.

*The discrete pattern of the rigid compression struts based on initial origami geometry.*

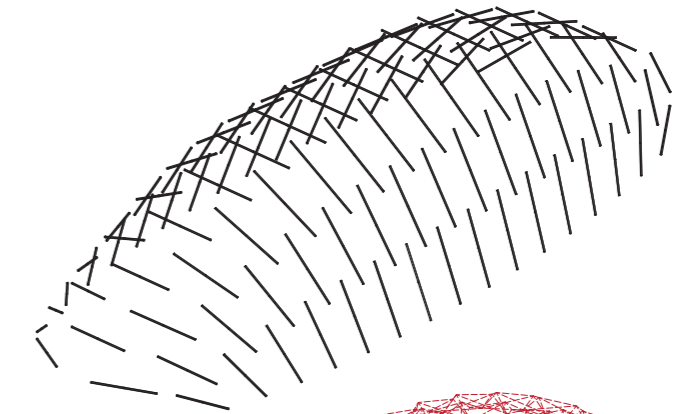

*Pattern of the continuous tension cables based on initial origami geometry.*

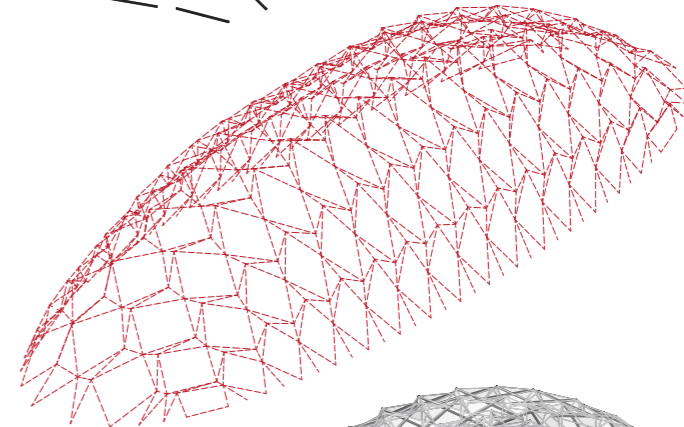

*Geometrical result after applying tensegrity principle into the origami geometry and reached self-equilibrium state.*

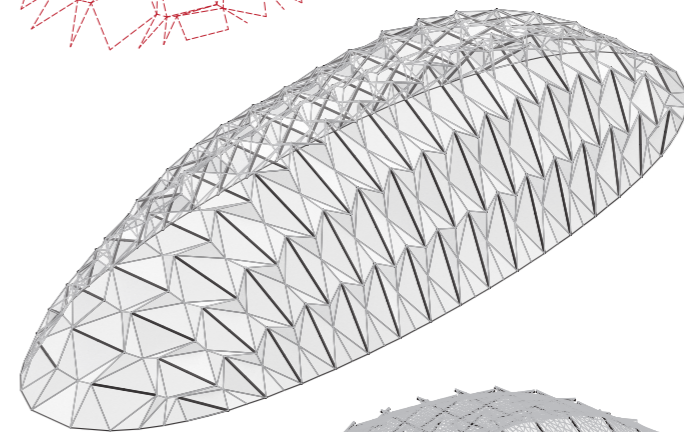

*Fig. 07. Final simulation of MOOM pavilion with the presentation of elastic membrane and detached rigid aluminum bars.*

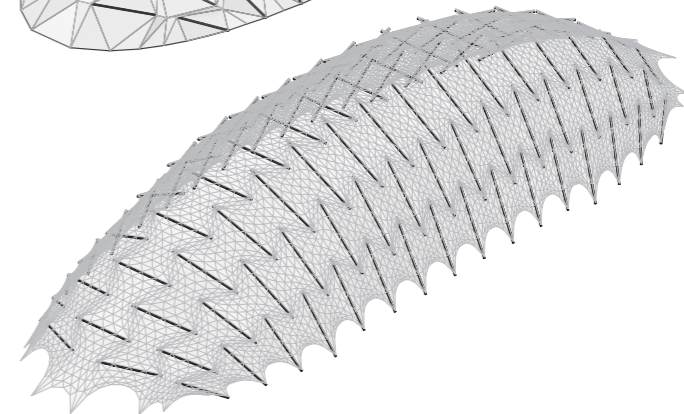





## CHAPTER II.

### II. Membrane-Tensegrity

*This chapter tends to build a sound image about Tensegrity. As a structural principle, tensegrity has been applied in nature, art and architecture. Besides, an introduction to the development on exploring and experimenting tensegrity as a structural principle applied in art and architecture in historical perspective. Moreover, the application of membrane into tensegrity structure will be demonstrated.*

*The chapter consists of three sections:*

*1. Tensegrity as a natural structure.*

*From case study to theory, introduce tensegrity as a natural structure principle has been applied and developed in a hierarchical way from Biology studies.*

*2. History of tensegrity and its classical models.*

*Story-telling about the development of tensegrity principle in a historical perspective. Besides, a brief introduction of classic tensegrity models is included.*

*3. Membrane and membrane-tensegrity structure.*

*From classic tensegrity to Membrane-tensegrity structure, the principle behind the transmutation will be introduced in this section, in the meanwhile, a brief introduction of two types of elastic membrane that have been commonly used in Architecture.*

## II. Membrane-Tensegrity

### 1. Tensegrity as a natural structure.

In order to build a sound knowledgeable image about membrane-tensegrity, it is essential to firstly understand Tensegrity. Tensegrity is one of the “simplest” and most efficient structural principle. It is based on a discrete distribution of isolated components of compression within a continuous net of tension. As shown in the diagram (*Fig. 08*) below, the independent struts in red are apart from each other while at the same time connected with the continuous tensional cables. In tensegrity structures, the compressed members which are rigid so that their tensional deformation can be ignored and they do not touch each other, while the pre-stressed tensioned members who have various values of elasticity depend on the various materials. After several iterations of deformation of the compressed-struts and stressed-cables network, tension and compression forces will be equivalent and balanced, where the structure reaches the self-equilibrium state.

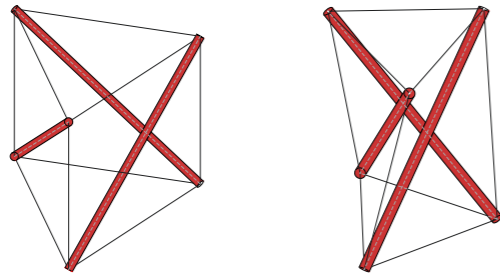

*Fig. 08.*  
*Three-strut*  
*tensegrity model*

Although tensegrity is a relatively new structural typology, it has been widely applied in nature during the process of evolution. The structures of human body as well as many living creatures on earth in multi-scales are constructed mostly in tensegrity principle. Since tensegrity had been discovered and described by Buckminster Fuller in 1960s, biologists had been studying tensegrity as a structural principle that has been possibly applied in nature from micro-scale: individual molecules to multiple body scales, and to mega-scale: the whole living organism, with various materials working in different hierarchies to build up a state that the structure of organism is able to respond to exterior interventions and reach equilibrium responsively.

To generally introduce how does tensegrity efficiently construct our cells and bodies, it is essential to start with cell structure and cellular tensegrity. The shape and mechanical stability of living cells are governed by an internal molecular framework which is known as the cytoskeleton (*Fig. 09*). Micro-filaments, micro-tubules and intermediate filaments compose the three major filaments components of the cytoskeleton. They are linked to themselves by various cross-linking proteins.

From the *Journal of Cell Science* 116 and the established models of cell mechanics, the cytoskeleton behaves like a discrete mechanical network. The pre-stressed filaments and pre-compressed microtubules equilibrating each other without any external supports. Through deforming and re-forming the whole structure, the whole cell will finally be stabilized. Consequently, a local stress can result in global structural rearrangements until a new equilibrium configuration is reached.



*Fig. 09.*  
*Neuron cytoskeleton*

## 2. History of Tensegrity and its classical models.

Tensegrity, was firstly described by Buckminster Fuller as an architectural principle (Fig. 11), while the birth of Tensegrity was in 1948 when artist and sculptor Kenneth Snelson produced his innovative “X-piece” (Fig. 13) after artistic explorations at Black Mountain College, where Buckminster Fuller was teaching.

Fuller is an iconic architect, engineer, and poet, who had imagined a world with full of unconventional structures that can possibly reach their stability through a pervasive tensional force, hence termed tensegrity. Fuller believed that natural forms were the result of matter being acted upon by force and, in 1917, he proposed that nature itself is a finite energy system consisting of the forces of tension and compression acting synergetically. Based on that, he started exploring and describing the synergetic principle of continuous tension with detached compression in structures in the 1920s. Besides, Fuller had always been concentrated on spherical forms as his personally preference. The “Biosphere” geodesic dome he designed as American pavilion for the 67th Expo in Montreal (Fig. 12) and the spherical tensegrity model displayed below (Fig. 11) are both the most well-known master pieces of Fuller. In 1948, he was invited to teach at Black Mountain College and his student Kenneth Snelson, who created the first structure which could be defined as “tensegrity”. The famous “X-piece” by Snelson with two X-shaped wooden struts suspended in the air by a taut nylon cable (Fig. 13). Unlike his teacher Fuller, Snelson would argue that tensegrity is a principle which is recognized only through man-made objects.

With the birth of the first “X-piece”, Kenneth Snelson had been credited for discovering the tensegrity principle by Mr. Fuller. Unlike researchers in architecture and engineer fields, Snelson mostly worked on small scale and modular sculptures which show clearly the beauty of tensegrity.

Forward to a bigger scale into musculoskeletal, according to *Theodore Dimon, Jr's* paper, *The Organization of Movement (2010)*, muscles everywhere in human body work in a partnership with the bones to produce a latticework of support (Fig. 10). Muscles in body structures are kept lengthened by the skeletal system, and instead of simply contracting, the muscles are suspended elastically in a latticework of bones. The skeletal system, as a varied and complex system of struts, maintains stretch on muscles and resists the pull of muscles, tendons, and ligaments. In the meanwhile, the elastic muscles maintain continuous tension to support the bones. In this way, the dynamic movement in tensegrity principle enables us to maintain support in the gravitational field with a minimum of effort and strain.

Overall, from the scale of cellular cytoskeleton to the lattice network of bones and muscles, the usage of multiple layers of tensegrity principle in different sizes with various materials all over different structural hierarchies composed an efficient and environmental responsive living mechanism.

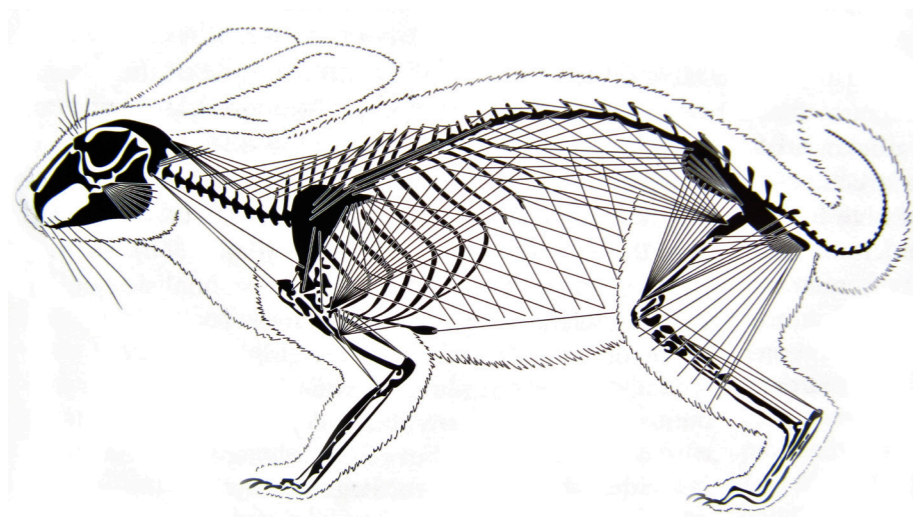

Fig. 10.  
Muscle-bone network  
in a bunny

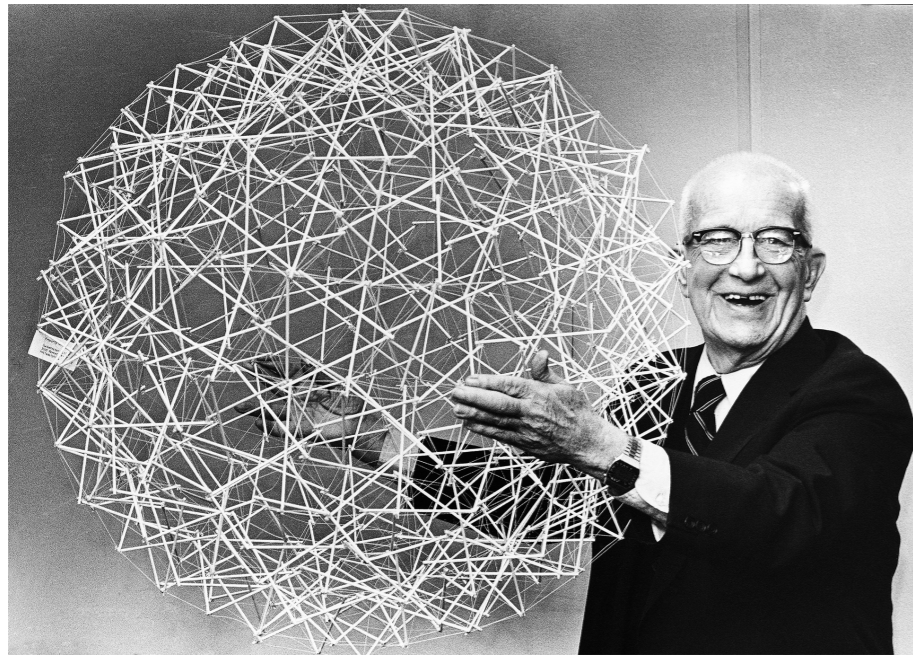

Fig. 11.  
R. Buckminster Fuller  
holds up his tensegrity  
sphere.



Fig. 12.  
Biosphere geodesic dome

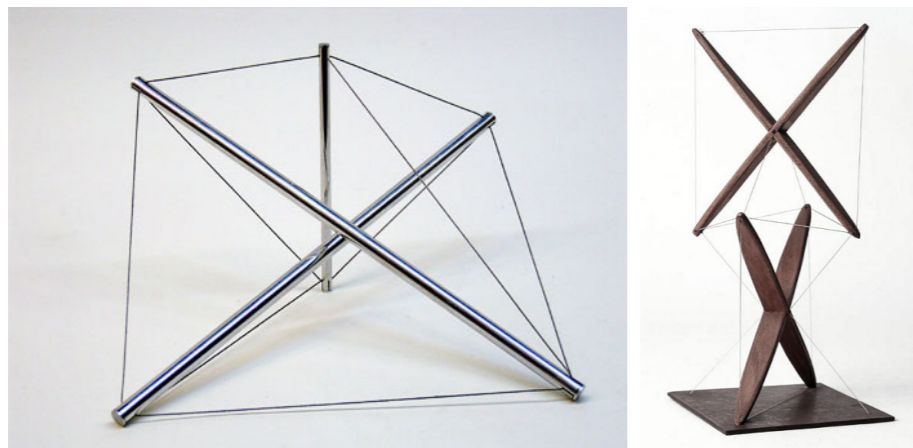
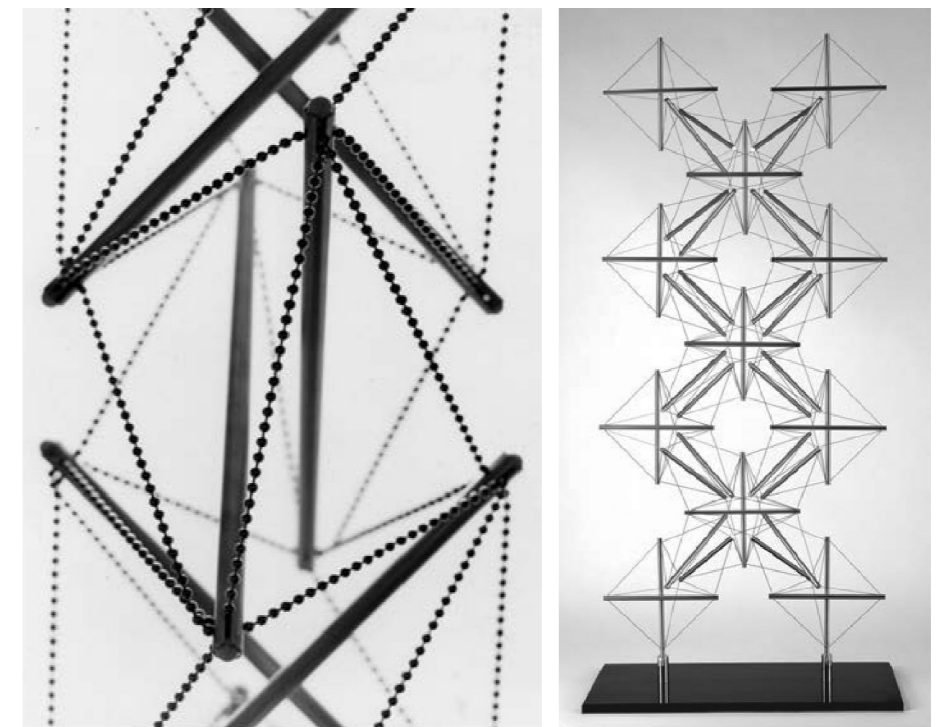

Fig. 13.  
Classic X-piece

In 1959, Snelson had begun his exploration with the conventional kite-frame and he found that the structure as a module could be potentially repeated infinitely in all directions. One of his famous experiments in the early time is the “BeadChain Tower” (Fig. 14). By smartly using bead-chain as the tension element, the calculation of the lengths of tensional element as well as the elasticity goes quickly and precisely.

Furthermore, after Snelson had applied for tensegrity patent, he began to experiment on planer models. Except the classic X model itself is a planar structure since the modular X piece could be repeated in x and y directions, he identified weaving with tensegrity by abstracting the woven elements as rigid compression components while remain detached, in the meanwhile, the tensional strings are symmetrically pre-stressed to form a planar equilibrium structure (Fig. 15). After the small-scale experimental models had been succeed, Snelson turned into structural scale and built a skeleton which is six feet square, weighing only twelve pounds. (Fig. 17)



left to right:  
Fig. 14.  
BeadChain Tower  
Fig. 15.  
Repeated X-piece  
sculpture by K. Snelson.

### 3. Membrane and membrane-tensegrity structure.

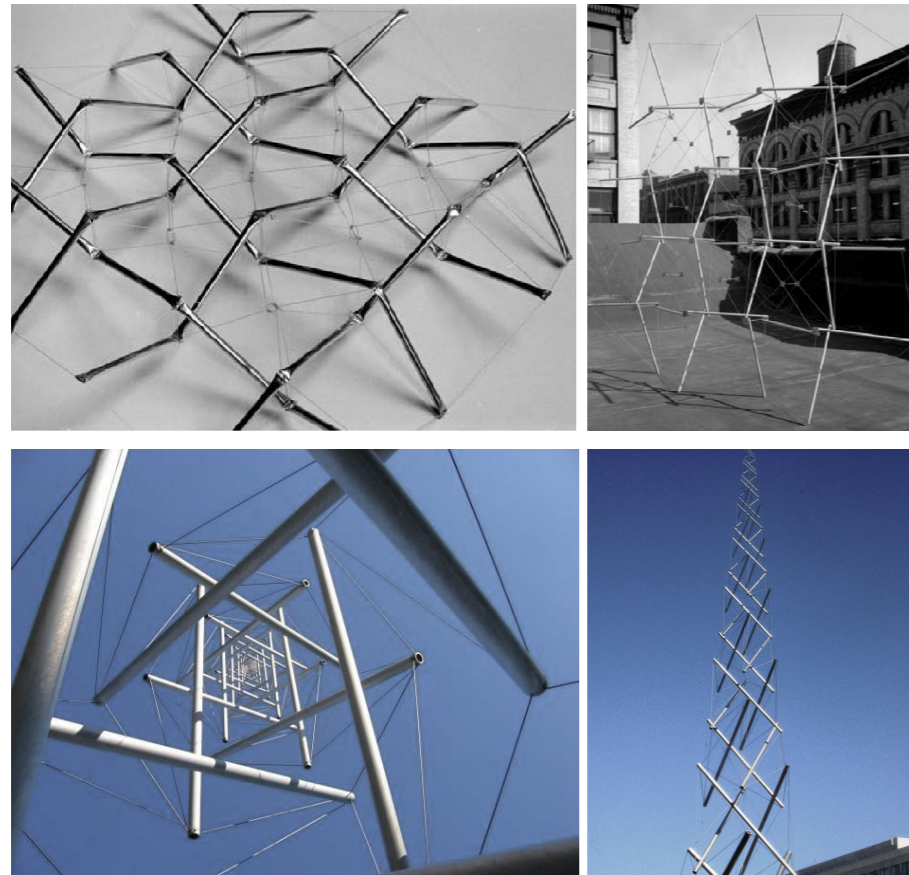

*left to right:*  
Fig. 16.  
*Weaving-tensegrity in planar, by K. Snelson.*  
Fig. 17.  
*Structural scale weaving-tensegrity sculpture.*

*left to right:*  
Fig. 18.  
*Needle Tower from bottom to top.*  
Fig. 19.  
*Needle Tower.*

Kenneth Snelson is a productive artists in the way of exploring and defining tensegrity with various sculptures as well as large scale structures, the Needle tower (Fig. 18; Fig. 19) is one of the most representative ones. The beauty of tensegrity and “floating compression” has been shown decently in Needle Tower.

After the efforts from both Buckminster Fuller and Kenneth Snelson, Tensegrity, as a decent and efficient structural principle has been brought on the table. And in the following 60 years, tensegrity, as a relatively new rule, inspires multiple disciplines especially in biology, medicine, and architecture fields.

As introduced above, the most of the tensegrity models that have been studied and constructed are in strut-cable skeletal forms and has been utilized in modular structures. Yet the goal in this thesis study is to apply tensegrity freely as a holistic principle instead of a modular principle for architectural design. Moreover, to apply tensegrity principle into architectural structure design, the skeletal characteristic will limit the functional possibilities of the design, since it does not provide any clear boundaries and divisions between exterior environment and interior spaces. Therefore, it is essential to efficiently combine possible covers with tensegrity models by following the rule of tensegrity.

Referring to membrane architecture, particularly the tensile structures, in which all the membrane are pre-stressed and fully tensioned when the structure stabilized. Elastic fabrics, applied in tensile structures and other membrane structures, are woven by millions of singular elastic fibers and overall present the ability of elasticity. Thus, elastic membrane could be possibly serve the same function as the elastic cables in the classic skeletal tensegrity structures. However, differs with the efficient strut-cable tensegrity structures, where there is always a single thread logically situated in between the two endpoints of struts in the tensional force vector direction, a continuous piece of membrane in tensegrity model stressed in hierarchical ways. Because of the transmission of tension force always goes for the shortest path, thus not all parts of the membrane will be fully stressed. Hence, critically, membrane-tensegrity is less efficient in the way of material usage compared to the classic models. Yet, having a solid architectural envelope as compensation makes membrane-tensegrity a worthy topic in architectural structure design.

According to two articles posted online named The Materials of Tensile Fabric Architecture and Using PTFE Glass Cloth by Architen Landrell, there are two types of membrane materials that have been most commonly used in membrane architecture, PVC (Poly Vinyl Chloride) coated polyester cloth and PTFE (Poly Tetra Fluro Ethlene, also named Teflon) coated glass cloth. According to the article, PTFE has been recognized as the highest quality architectural membrane for tensile structures, and PVC coated polyester had been used as an economical alternative to PTFE cloth.

PTFE is extraordinary in thermal performance, solar performance and lifespan as well as maintenance as a membrane material for architectural structures. The insulate properties of PTFE coated glass is similar to the performance of conventional glazing. And all PTFE coated glass cloths are inherently non-flammable while are able to transmit 15% of sunlight, and reflect 75% of sunlight. Thus, the structure could present ideal white color because of the reflection and natural interior light because of the transmission. Besides, as lightweight material with limited mass, PTFE fabric roofs are acoustically relatively transparent, but provide a degree of absorption and noise attenuation, which is particularly helpful for inner courtyards.

To sum up, the approach of applying elastic membrane into tensegrity principle in order to substitute strings frees more spatial possibilities in architectural design process.



Fig. 20.  
PVC polyester



Fig. 21.  
Tensile structure applied  
with PTFE



Fig. 22.  
Tensile structure applied  
with PVC polyester



## CHAPTER III.

### III. Generic digital tool for designing freeform membrane-tensegrity structure

*This chapter demonstrates the development of a generic algorithm for constructing freeform membrane-tensegrity structures from theory and digital tool study, to various experiments of simulations based on the theory.*

*The chapter consists of three sections:*

*1. Digital tools and experiments for tensegrity simulation.*

*Introduction of digital tools that used for computing and simulating.*

*2. Algorithm for constructing freeform tensegrity in theory and the development of a digital tool based on the algorithm.*

*Introduce an inspiring theory which describes a generic algorithm to construct freeform tensegrity structure in a theoretical approach.*

*Demonstrate and present the process of developing grasshopper definition as a universal design tool for simulating tensegrity structure from arbitrary initial geometry.*

*3. Generic algorithm of freeform membrane-tensegrity.*

*Demonstrate and present the behaviors of mesh surfaces during the tensegrity form-finding process. Building up two steps of form-finding relaxation to simulate fine membrane-tensegrity structure.*

*4. Optional geometric constrains for designs.*

*Listing multiple optional parameters that could influence the geometric form of membrane-tensegrity structures.*

### III. Generic digital tool for designing freeform membrane-tensegrity structure

#### 1. Digital tools and experiments for tensegrity simulation.

Membrane-tensegrity as a type of responsive structure that is dynamically searching for the equilibrium form where the internal tension forces and compression forces balance each other, when local or global forces apply on the surface. In order to generalize the structural concept of MOOM pavilion to open more architectural design possibilities, I would like to develop a digital tool which could simulate tensegrity structures in a generic and systematic way instead of being limited into modules. Essentially, the shapes of tensegrity structures are governed by the equilibrium of forces. Forces directly determine the final form of tensegrity structures as well as membrane-tensegrity structures. Therefore, basically the goal is to build up a digital relaxation process for pre-defined freeform geometries to approach force equilibrium state. Furthermore, the digital tool would contribute to the further fabrication and manipulation in architectural design.

During simulation, the form-finding behaviour demonstrates how the force functions reflect on the changes of the initial strut-cable composition. Tensional cables perform elastic deformation response to compression forces and the re-positioning of compression struts response to the deformation of tension cables. After that, the final pattern of both tension cables and compression struts accommodate in a stabilized tensegrity model which could be clearly defined when the forces are in equilibrium.

In order to develop a relatively precise computational form-finding simulation model of tensegrity, the computational tools are essential. In this thesis, the applied programs are Rhino 6 for 3-dimensional geometry modelling; Rhino 6 plug-in Grasshopper; Python in Grasshopper; Kangaroo physics; Kangaroo 2; as well as other plug-ins in Grasshopper like Weaverbird; Cocoon; Lunch Box etc. to develop a generic algorithm for freeform tensegrity form-finding.

Worth mentioning, Kangaroo is a powerful live physics engine for interactive simulation, form-finding, optimization and constraint solving. It can generate structures in static equilibrium in a simple and intuitive way by using dynamic relaxation.

To simulate the form-finding behaviours on struts and cables under forces in tensegrity, I started with observing the same behaviour on the simplest geometry, a planar triangle, under a defined vector force field before reaching its final equilibrium state. As shown in the diagram (Fig. 23.), I set up a generic singular layer triangle surface to begin with, and scaled each edge on the surface corresponding to the force value that they bear locally. Since the force value and density are the same on every edge in this case, each edge scaled the same value. As shown in (b), the orientation of face edges are defined in counter-clockwise. Hence, taking the start points of the edges and pulling them together with attraction forces (vector force shown in red lines) during the relaxation process. Thus, as shown in the last two graphs in the diagram, after multiple iterations of equilibrating and form-finding process in Kangaroo (the digital live physics engine which could simulate force interactions in real-time and reflect the result graphically in Grasshopper interface), the pulling behaviour has been stopped and the geometric form (with blue boundary) is stabilized, while spinning around with the defined force orientation yet without constant form-changing.

Fig. 23.

- (a) Initial mesh surface.
- (b) scale each edge equally in counter-clock wise.
- (c) Vector force field in the same direction.
- (d) start point pulling each other by the given vector force.
- (e) form stabilized while spinning along the force direction.

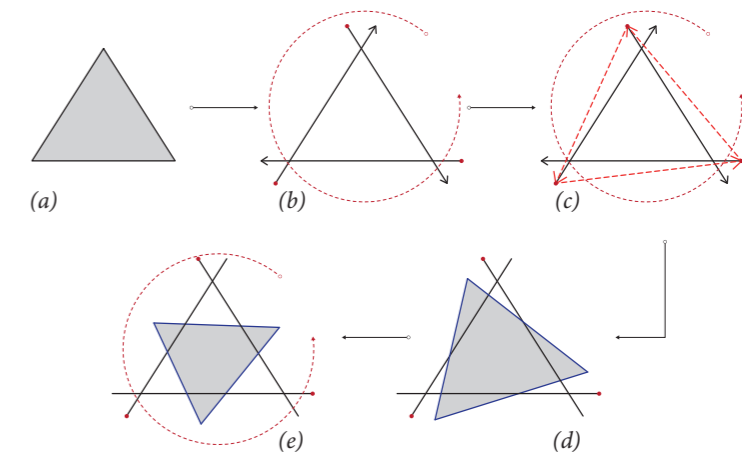



Having acknowledged the basic form-changing behaviour on a planar triangle under a vector force field, in order to observe the behaviours of struts and cables under the internal compression and tension forces interactions, I started constructing a simple tensegrity structure with only three compression elements and the relative connected cables.

As shown in the diagram (Fig. 24.), the same planar triangle is applied to begin with (a). First, the essential three rigid struts could be extracted from the initial triangle by isolating its edges and scaling the three edges in a certain scale based on their middle points (b). To clarify the behaviours of struts and cables when equilibrating internal compression and tension forces, I defined one value for scaling the edges as 1.2. Until then, the struts are prepared, although they are intersected with each other since they accommodate in the same plane from the planar triangle. Second, therefore, according to the rule of tensegrity that the compression elements should not touch each other, one of the endpoints on each edge, which could be chosen either in clockwise or in counter-clockwise, could be lifted to avoid intersections (c). Hereafter, the lines in red colour resemble the elastic cables in tensegrity, could be connected logically with the struts (d). In tensegrity principle, the struts and cables should be pre-compressed and pre-stressed to supply the corresponding forces, thus, the two elements could be regarded as springs with different defined elasticity in digital simulations. The three rigid struts are defined to be stiff springs that have no elasticity, while the cables are granted into various elasticities. The defined target length could resemble the elasticities of springs. As presented in the diagram, the values in the first structural result (e) is 1.0 times initial edge length for the cables, and 0.7; 0.4; 0.1 separately in the following three results, in the meanwhile, the length of the struts remains the same as 1.0. Therefore, it is clear that the more target length value decreases, the more elastic is the spring, and the more tension forces tend to be supplied.

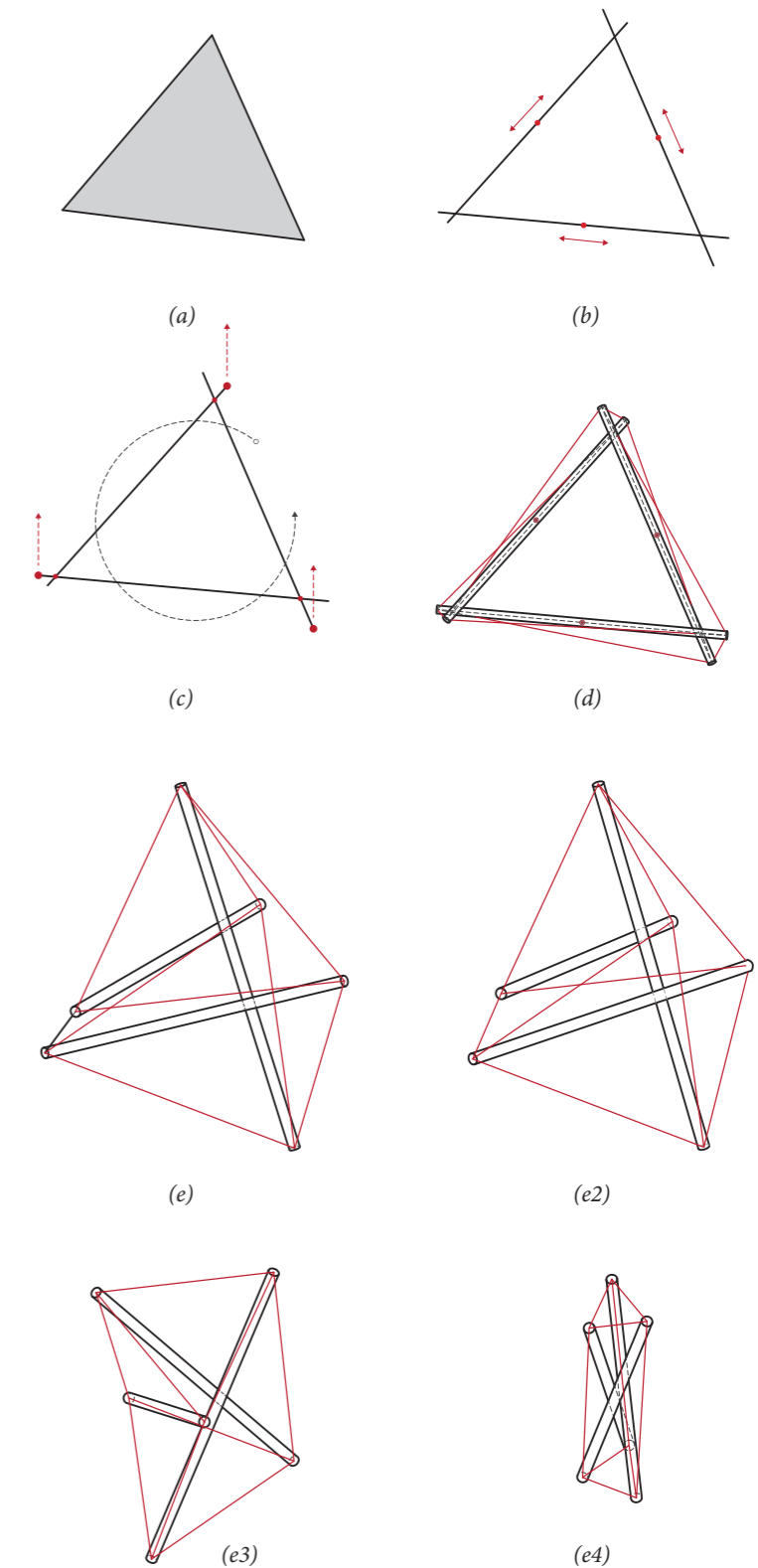

Fig. 24.  
From top to bottom shows the process of constructing a simple tensegrity model with only three struts from a planar triangle.

## 2. Algorithm for constructing freeform tensegrity in theory and the development of a digital tool based on the algorithm.

From the two experimental cases described above, the basic procedures of simulating tensegrity models are clear when the initial geometry is locally defined. However, there should be a more generic algorithm developed for tensegrity form-finding in order to free the initial geometry as well as the limitations of tensegrity design in architecture.

In order to develop a generic algorithm for tensegrity form-finding in architectural design from an arbitrary initial geometry, a solid methodology which orients the algorithmic development is essential. Referring to the paper *Interactive Freeform Design of Tensegrity* written by Tomohiro Tachi from the University of Tokyo, a novel method for flexibly designing tensegrity structures under valid force equilibriums will be a guidance for the corresponding algorithm development in this thesis. The goal that stated in Tachi's paper is to theoretically structure a logical and generic approach for tensegrity form-finding within a multidimensional space. Many existing methods introduce that using predefined parameters or an objective function in order to obtain a unique geometrical solution after form-finding process. However, from architects perspective, the predefined numeric parameters or functions are too abstract to reflect directly on spatial design. Therefore, instead of obtaining a unique solution from predefined parameters or functions, Tachi proposes an interactive design space with the possible and optional geometric constrains. Designers therefore will have more freedom to design with arbitrary initial geometries from the certain limitations based on different contexts and commissions.

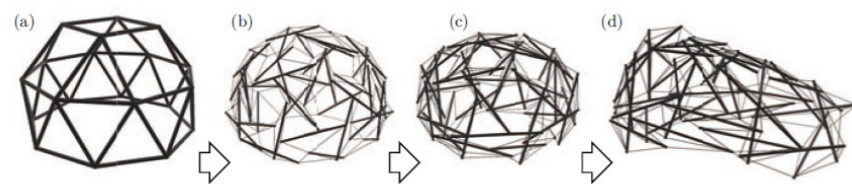

Fig. 25.  
 (a) Given polygonal mesh in 3D space.  
 (b) Generated topology related to the initial polygonal mesh.  
 (c) Valid initial configuration in equilibrium.  
 (d) An interactive freeform variation of (c).

Thus, the procedures for constructing a tensegrity structure consist of three main steps: 1. Topology Generation Step; 2. Form-finding Step; 3. Interactive Design Step. Importantly, in order to observe the behaviour of elastic membrane as the tensional member during force equilibrium and form-finding process, there should be an additional manipulation that substitute cables with membrane to form an overall self-standing membrane-tensegrity structure.

### Topology Generation:

Topology generation is very crucial during the whole process since it provides a clear structure of rigid struts and elastic linear connections as a basis for form-finding. According to Tachi's description, a strut-cable network that topologically the same as the initial mesh geometry could be constructed as the initial configuration for tensegrity form-finding. The following three steps demonstrate that a general given polygonal mesh could be converted into a strut-cable network.

01. Isolate each edge and independently rotate it with a certain angle that could be flexibly and interactively chose by architects along an axis passing through its midpoint parallel to the surface normal. These edges are defined as struts.

02. Connect the endpoints of struts that generated from 01 with cables to form each m-gonal closed loop corresponding to an m-valency vertex. For example, as shown in diagram (Fig. 28. (e)), there are five edges pass through vertex V, thus the valency on vertex V is five. Corresponding to the valency, the connections shown in blue lines form a 5-gonal closed loop.

03. Connect the endpoints of struts that generated from 01 with cables to form each n-gonal closed loop corresponding to an n-gonal facet. For example, in diagram (Fig. 28. (e)), the facet of face F colored in faint red is three since F is a triangle. Corresponding to the facet, the

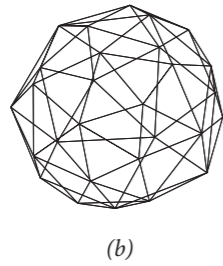
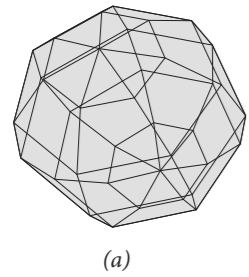

Fig. 26.  
 (a) Normal mesh polygon  
 (b) Remeshed mesh

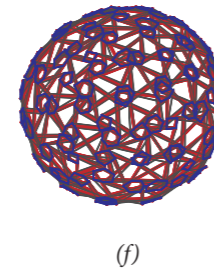
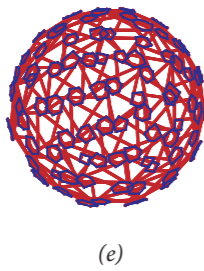
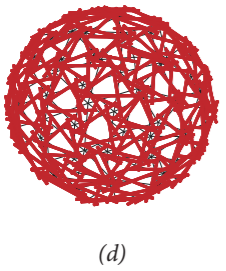
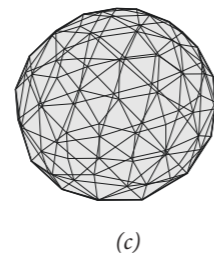
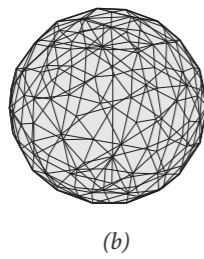
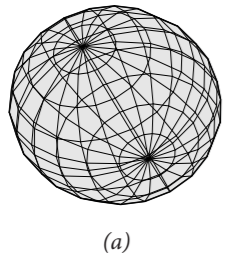

Fig. 27.  
 (a) Mesh sphere.  
 (b) 1 iteration remeshed.  
 (c) Stabilized mesh polygon after remeshing.  
 (d) Struts.  
 (e) Struts with connection 1.  
 (f) Struts with connection 2.

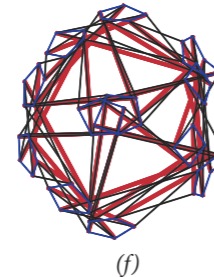
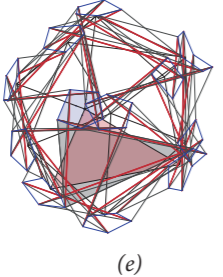
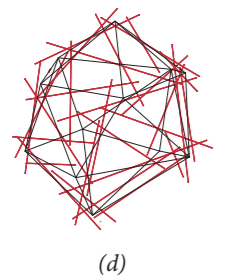
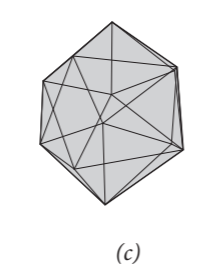
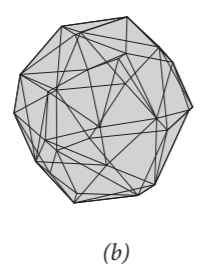
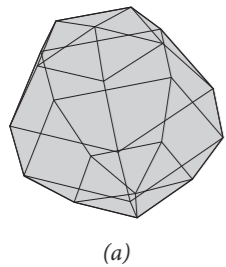

Fig. 28.  
 (a) polygonal mesh.  
 (b) 1 iteration remeshed.  
 (c) Stabilized mesh polygon after remeshing.  
 (d) Struts.  
 (e) Struts with connection 1.  
 (f) Struts with connection 2.

connections shown in grey lines form a triangular closed loop.

Following the description above, I started developing a series of experiments with various initial geometries. As shown in the diagram (Fig. 27.), I firstly started with a mesh sphere. In order to simplify step 03 above, it is less problematic to triangulate all the faces on the mesh geometry, therefore, the initial mesh sphere should be remeshed, so that the connections of endpoints described in step 03 will always be in triangular shape ( $n=3$ ), no matter how many types of facet are inherent in the initial geometry. Besides, after the remeshing process, the initial mesh sphere will not only be triangulated, but be converted into a plankton mesh which is a half-edge data structure contains multiple types of topological information within the initial mesh surface.

Next, the new mesh edges from the remeshed plankton mesh should be extracted and rotated as shown in the red lines in the diagram (Fig. 27.). The value of the rotation angle and the length of the edges are defined by architects, besides, the parameters could be interactively modified during the design process. Until then, the struts as compression elements for tensegrity form-finding is prepared.

It is obvious that the pattern of the generated struts matches reciprocal structure, since the orientation of rotation for each edge is identical, either clockwise or counter-clockwise (refer to Fig. 23.). Thus, to connect the endpoints on each strut correctly by following the step 02 above, the method of finding the closest neighbour points logically in the pool of endpoints on each edge applied as the quickest and clearest way to form the m-gonal closed loop corresponding to an m-valency vertex. However, to accomplish the cable connections by following the step 03 above, the approach of closest point finding is not suitable universally on freeform initial geometry since some errors might be generated if the shape and size of neighbour faces differ dramatically. Hence, a new

approach that constructing vectors based on the rotated edges with a certain direction corresponding to the embedded direction on each strut and connect start points on the vectors depend on individual mesh face.

After all three steps, as presented above (Fig. 27; Fig. 28.), the strut-cable topology is generated based on the topological information from the fed initial mesh polygon. Consequently, the initial configuration for tensegrity form-finding is prepared.

In the form-finding step, the initial configuration is modified constantly in order to have a valid equilibrium state. In tensegrity, the domestic forces which are searching for equilibrium are clear. The deformation of strut-cable topology caused by the pulling and pushing behaviors while the forces try to balance each other. From the strut-cable topology, the function and mission of each line is clear. During form-finding, all the positions and directions of struts tend to be changed continuously according to the deforming movement of cables while the parameters of strut lengths are always fixed. On the other hand, the elastic cable lines compromise the force equilibrium process by constantly changing their positions; lengths; and directions according to the constant deforming movement of struts. Moreover, other than the domestic forces embedded in the system, the exotic force, for example the gravity, is necessary to be considered for form-finding simulation.

During the process, the parameters, for example strut lengths; positions of the struts; cable elasticity; as well as the external force value are the key factors that directly influence the geometrical result of tensegrity structure. These parameters are flexible and largely influence the overall image of tensegrity structure, and they could be defined and interactively modified by architects reflect from the result of tensegrity form-finding. Continue experimenting three polygon mesh as in a

hierarchy of complexity (Fig. 29; Fig. 30; Fig. 31.), the results are shown below when the tensegrity form-finding are controlled by various parameters.

Fig. 29.

**Geometry: icosahedron**  
 Strut length: edge length  
 Strut rotation angle: 0.3  
 Cable elasticity: fully stressed  
 External force value: 0.0

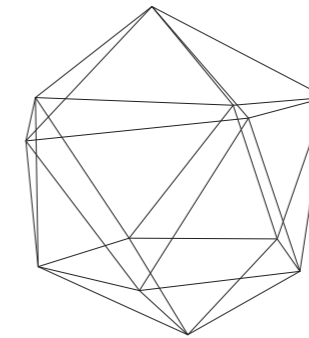

(a)

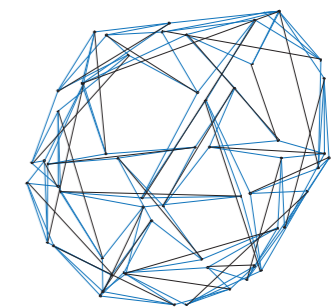

(a')

Fig. 30.

**Geometry: mesh sphere**  
 Strut length: edge length  
 Strut rotation angle: 0.3  
 Cable elasticity: fully stressed  
 External force value: 0.0

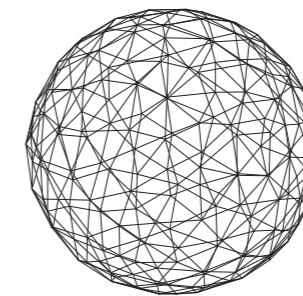

(b)

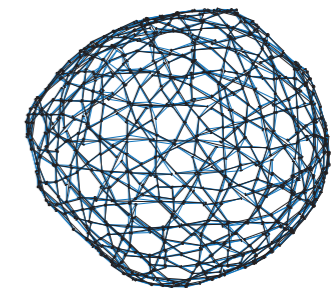

(b')

Fig. 31.

**Geometry: arbitrary mesh polygon**  
 Strut length: edge length  
 Strut rotation angle: 0.3  
 Cable elasticity: fully stressed  
 External force value: 0.0

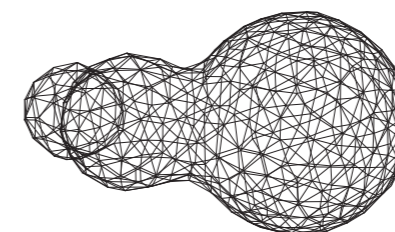

(c)

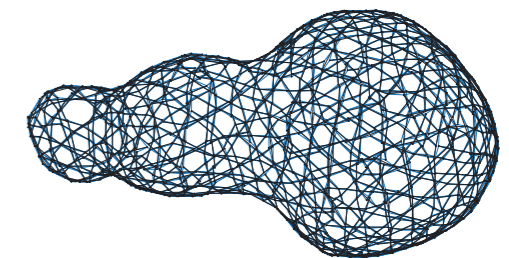

(c')

All three mesh geometries are evenly triangulated. Therefore, the form and complexity of tensegrity structure relates directly to the form and complexity of the initial geometry. According to the function of remeshing, when the remeshed edge equals to the average length of edges on the initial geometry, the complexity of the initial mesh geometry will not be changed during remeshing process.

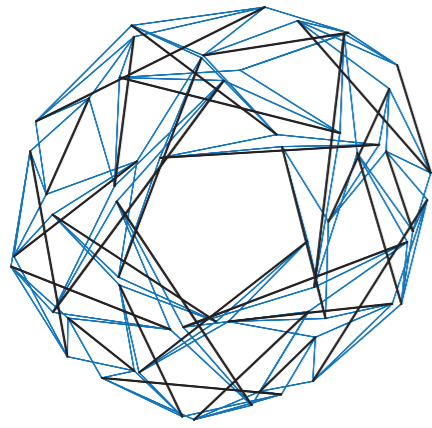

(a)

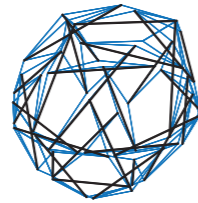

(a')

Fig. 32.  
 Geometry: icosahedron  
 Strut length:  
 left: 2.0 edge length  
 Right: 0.9 edge length  
 Strut rotation angle: 0.3  
 Cable elasticity:  
 fully stressed  
 External force value: 0.0

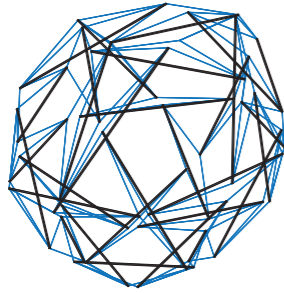

(b)

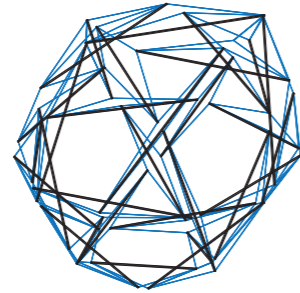

(b')

Fig. 33.  
 Geometry: icosahedron  
 Strut length: edge length  
 Strut rotation angle:  
 left: 0.6; right: 0.1  
 Cable elasticity:  
 fully stressed  
 External force value: 0.0

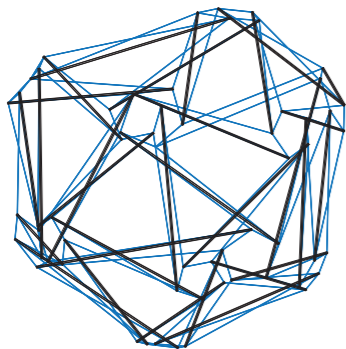

(c)

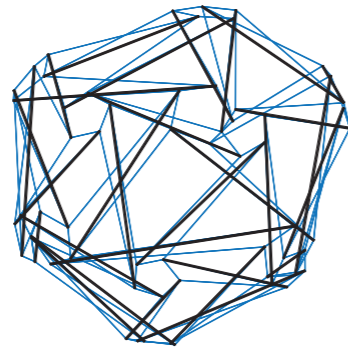

(c')

Fig. 34.  
 Geometry: icosahedron  
 Strut length: edge length  
 Strut rotation angle: 0.3  
 Cable elasticity:  
 left: fully stressed;  
 right: non-stressed  
 External force value: 0.0

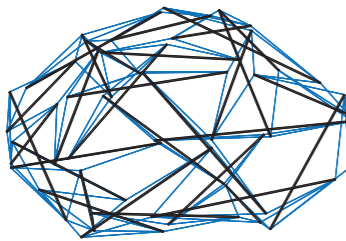

(d)

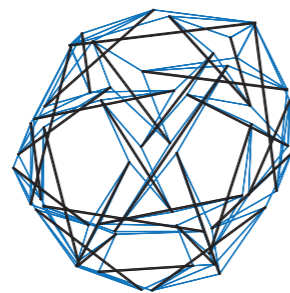

(d')

Fig. 35.  
 Geometry: icosahedron  
 Strut length: edge length  
 Strut rotation angle: 0.3  
 Cable elasticity:  
 fully stressed  
 External force value:  
 left: 10.0 point force  
 right: 0.0 point force

### 3. Generic algorithm of freeform membrane-tensegrity.

The approach of constructing tensegrity structure and simulating the form-finding process from defined given arbitrary geometries has been developed based on Tachi's theory. To sum up, the equilibrium form-finding within pre-compressed struts and pre-stressed cables could be translated digitally into the constant changing strut-cable topological configuration which generated from the given geometry. Correspondingly, architects can interactively design and modify the final tensegrity structural form by intervening the initial geometry and the parameters for generating the configuration, thus the design process becomes visible and controllable.

Furthermore, in order to develop a generic definition for membrane-tensegrity, it is essential to experiment the behavior of mesh surfaces represent membrane digitally during tensegrity form-finding process.

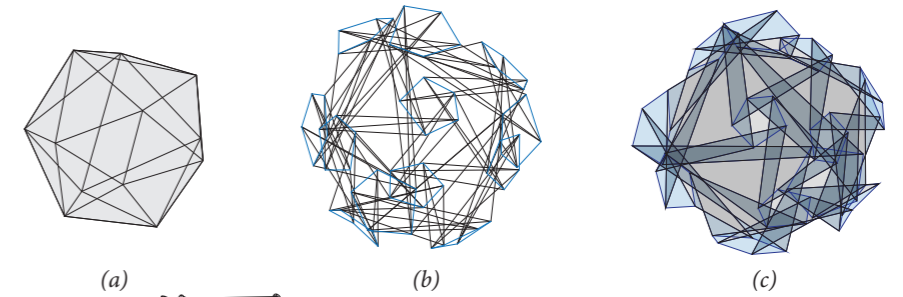

(a)

(b)

(c)

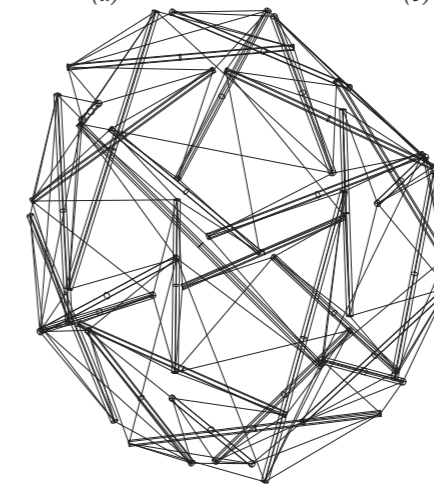

(d)

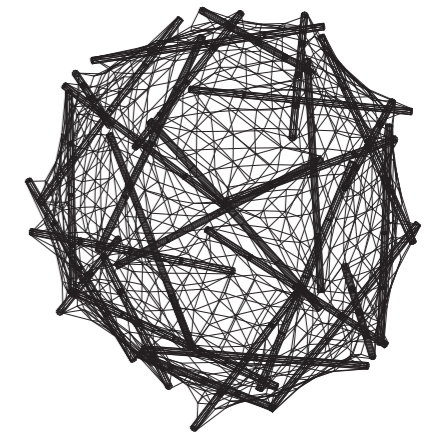

(e)

Fig. 36.  
 Geometry: icosahedron  
 Strut length:  
 1.6 edge length  
 Strut rotation angle: 0.3  
 Cable elasticity:  
 fully stressed  
 External force value: 0.0  
 Membrane pre-stress  
 ratio: 0.47

As mentioned, the topological strut-cable configuration is constructed based on the mesh edge curves, and the vital topological information for cable connections come from plankton mesh. Plankton mesh is a free and open library implementing the half-edge data structure for the initial polygon meshes; it stores the mesh topological information thus allows easier adjacency. Consequently, the constant changes of mesh behavior, which assembles membrane behavior during the whole form-finding process should be evaluated since the beginning, the initial mesh surface. Since the method of constructing strut-cable topology configuration manipulates on mesh edges only, the configuration of the corresponding surfaces should be generated logically as well to be a basis for the further membrane-tensegrity form-finding process. Referring to the structural pattern of the generated strut-cable system, there are three parts that consist the configuration by following the three steps proposed by Tachi. As illustrated in the diagram above (Fig. 36.), the isolated edges in black are the rigid struts, and the blue m-gonal closed loops corresponding to the local m-gonal valency; the gray n-gonal closed loops corresponding to the n-gonal local facet (in this thesis study  $n=3$ .) Following the topology pattern, the surfaces are closed logically as shown in the diagram. (Fig. 36. (c)) Consequently, after all the face segments are welded together, the simulated whole piece of membrane for tensegrity form-finding is prepared.

Yet, to make the self-equilibrium form-finding for membrane-tensegrity clearer, as well as easier to observe the behavior of membrane, I divide the process into two steps, as shown in the diagram, the membrane in the first force equilibrium form-finding has not been granted any elasticity, thus it does not influence the interactive form-changing between the strut-cable configuration as well as the final result of the tensegrity form. The first step could be defined as the strut-cable tensegrity form-finding with the illustration of closed membrane. After that, it will be the second step which is the final membrane-tensegrity form-finding simulation.

After the first tensegrity equilibrium state has been generated, I extracted the compression struts from the tensegrity structure for the second membrane-tensegrity form-finding. Besides, the key factor, membrane surface has to be extracted from the first form-finding process, since the positions and directions of struts and cables are newly defined after reaching equilibrium. Having the mesh surface which simulates membrane surface, it is necessary to refine the mesh in order to promote the accuracy of simulation. Subsequently, following the same approach of pre-stressing elastic cables in the first step, the refined mesh surface could be pre-stressed by a defined number or ratio between 0 and 1 depend on the elasticity of different materials. Until then, two key factors, the rigid struts and the elastic membrane are prepared for the membrane-tensegrity form-finding.

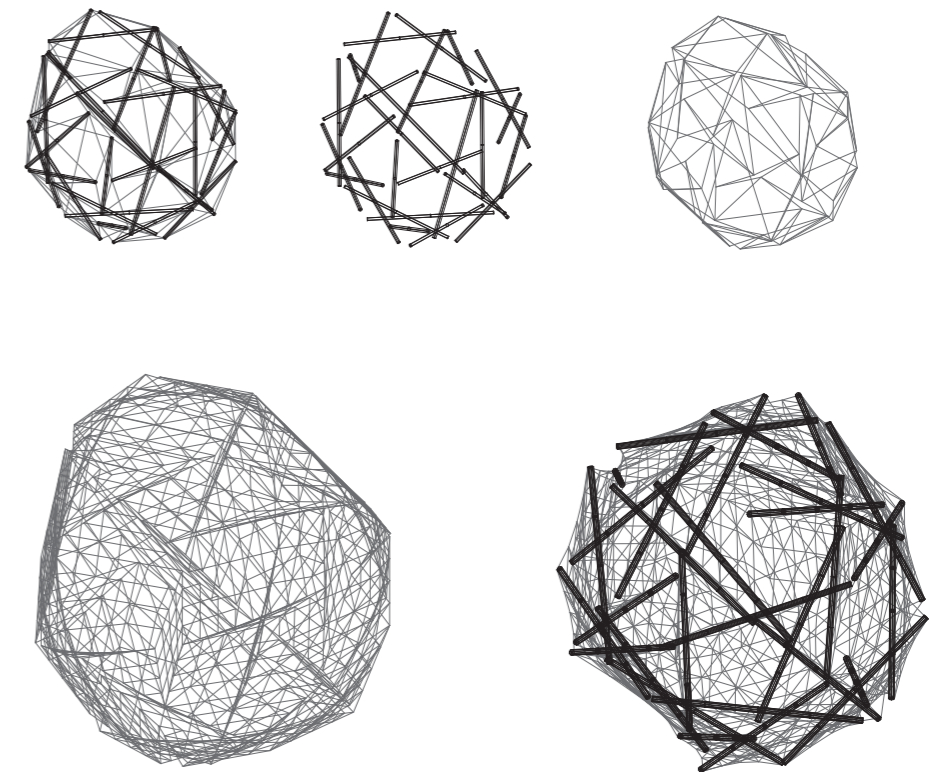

Fig. 37.  
Second membrane-tensegrity form finding with the same icosahedron.

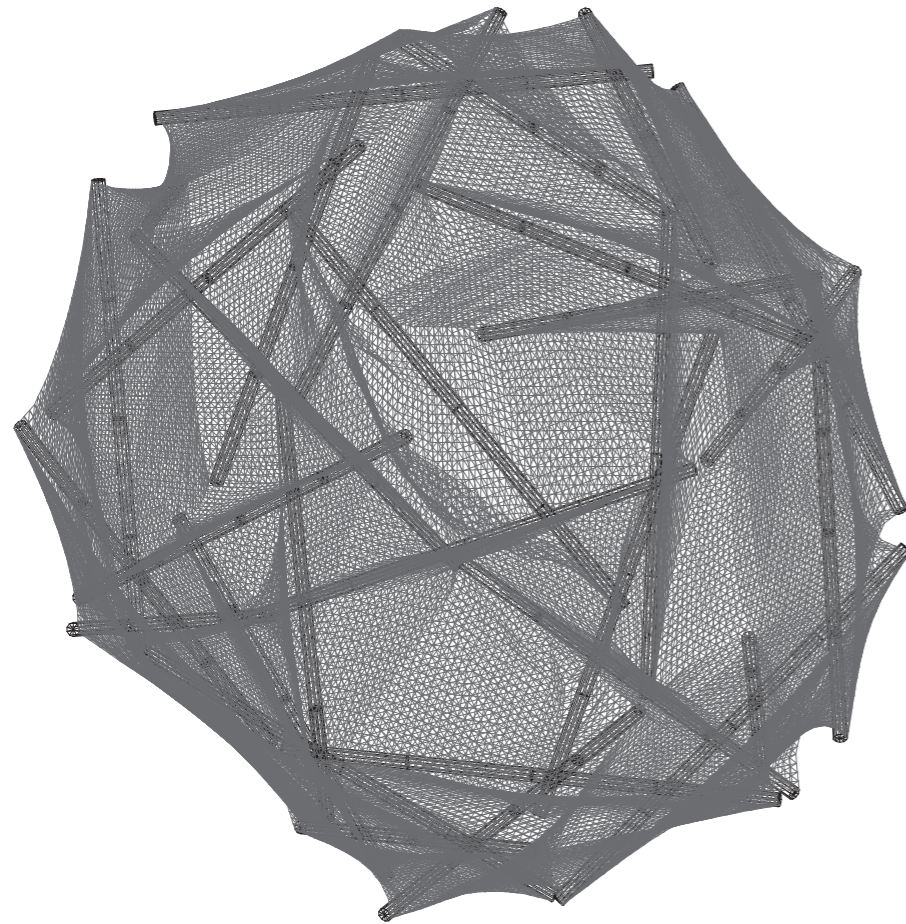

Fig. 38.  
*icosahedron  
membrane-tensegrity*

In conclusion, constructing membrane-tensegrity structures from arbitrary given geometries is a matter of simulating the constantly changing behaviors of the struts and membrane under the interactive interventions of compression and tension forces trying to balance each other and reach equilibrium. Thus, two of the most essential steps are worth being mentioned during the simulation.

First, constructing the strut-membrane configuration as a basis for the tensegrity relaxation form-finding. In order to construct a strut-membrane configuration which topologically the same as the designed initial geometry, a more abstract and clearer strut-cable topology configuration should be generated directly from the initial geometry, after which the strut-cable configuration could be transformed into the required strut-membrane configuration.

Second, the rule of having the discrete pre-compressed rigid elements and the continuous pre-stressed elastic elements must be clearly followed to simulate the tensegrity form-finding process which is controlled by the two interactive forces that try to balance each other and to define the final spatial configuration of membrane-tensegrity structure. Hence, feeding the different parameters to struts and membrane, as well as the cables separately, for example, rest lengths; elasticity; external forces etc. In order to simulate the physical properties of the rigid struts as the compression elements and the cables and membrane as elastic tension elements. More importantly, by granting different values to the two essential factors separately, the state of pre-compressed and pre-stressed could be simulated in a controllable way.

Thereafter, as the topology configurations described in the first step has been constructed, and the values of the corresponding parameters have been precisely defined by architects, the membrane-tensegrity form-finding could be visually simulated and serve as a basis for the possible practical fabrication process.

#### 4. Optional geometric constrains for designs.

Through the systematic and algorithmic design of freeform membrane-tensegrity structures, there are multiple chances where architects or designers could intuitively intervene the final structures, for example, designing the initial geometry which largely defines the geometric form of the eventual structure as well as defining the lengths and rotation angles of struts and the elasticity of cables and membrane.

Furthermore, referring to Tachi's theory, there are several optional geometric constrains which enormously free the limitations embedded in the structural design of membrane-tensegrity, and open the bigger possibilities for innovative architectural design and fabrication.

First, and the most helpful additional constrain is *Fixing to Reference*. The system enables the optional fixing of selected points to the chosen reference points or to the ground plane. Thus, the joints at the ground or attached with the reference points bear the structure weight and external load only, while the pre-stresses are balanced within the structure. Here, the application of membrane-tensegrity to architecture has been bridged since the multiple functional design of membrane-tensegrity according to its characteristics are opened. For example, the lightweight roof structure; pavilion; bridge design; as well as the bigger scale urban design. The design of the first membrane-tensegrity architecture MOOM pavilion described in the first chapter has applied this geometric constrains to set up the fixed points to the ground plane.

Second, forward from fixing specific points refer to the local conditions, the geometric constrain named *Fixed Length* enables the lengths of the defined elements in the strut-cable configuration keep the same value during the form-finding process. For example, after designing one configuration, the selected cables could be defined as the actuators for the form-finding, while other struts and cables stay the same lengths. Hence, the equilibrium form-finding could be reached locally according to the specific design requirement.

Moreover, the digital models of membrane-tensegrity structures becomes transformable. The transformation that can be realized from the relatively first generated structure by controlling the lengths of the actuators.

Last but not the least, the intersection avoidance of struts could ensure the rigid struts in the membrane-tensegrity system do not intersect with each other. Therefore, by applying pulling forces according to the local struts distribution, the intersection could be avoided. In order to distribute pulling forces locally, the distance between struts should be measured first. Thereafter, having the local distances, the value of the pulling force could be defined positively correlated to the local distances. However, the pulling forces would affect the equilibrium state in the whole system, because after the pulling forces functioned, the accommodation pattern of the struts is changed, so that the final result of the membrane-tensegrity form-finding tend to be changed correspondingly.





## CHAPTER IV.

### IV. Digital speculations of membrane-tensegrity structures.

*This chapter presents two design approaches from different perspectives of constructing generic free-form initial geometries for the developed digital tool. Correspondingly, two conceptual designs of membrane-tensegrity structures will be illustrated as demonstrators under two proposed design approaches.*

*The chapter consists of three sections:*

*1. Systematic and continuous design of membrane-tensegrity.*

*Indicating a design methodology in this thesis by comparing two different design methods from two built membrane-tensegrity structures.*

*2. Modular geometry repetition.*

*The first design approach of constructing generic freeform initial geometries for the digital tool will be introduced as modular geometry repetition.*

*3. Structural speculation of a membrane-tensegrity bridge.*

*With the guidance of modular geometry repetition design method, a freeform membrane-tensegrity bridge will be presented as the first demonstrator with a referencing environment.*

*4. Surface manipulation.*

*The second design approach will be introduced as surface manipulation for arbitrary freeform geometry.*

*5. Structural speculation of a membrane-tensegrity pavilion.*

*With the guidance of surface manipulation design method, a freeform membrane-tensegrity pavilion will be proposed as the second demonstrator with a referencing environment.*

## IV. Digital speculations of membrane-tensegrity structures.

### 1. Systematic and continuous design of membrane-tensegrity.

Referring to the design approach of MOOM pavilion, as analyzed in the first chapter, the elastic membrane is assigned as the continuous tensional member to substitute the connected multiple cables in the structure from the classic tensegrity model. In this way, the elastic fabric is constantly stressed and serves continuous tension, in the meanwhile balancing the compression from the rigid struts. Thus, as pure as the classic strut-cable tensegrity model, there are only two types of structural materials that force function interactively according to their properties.

Oppositely, other built structures like *Underwood pavilion* (Fig. 40.) designed by Prof. Reither and Prof. Wit and *Tension pavilion* (Fig. 41.) designed by StructureMode demonstrate a different approach which is closer to the classical way of manipulating tensegrity as modules yet further from my focuses in this thesis. Besides, instead of applying the elastic membrane as a continuous tensional member functions in tensegrity structures, the membrane is considered as an additional structural member that functionally covers the space and defines the boundaries between the interior space and the exterior environment. Meanwhile the focus of the design tends to be exploring the possible configurations of tensegrity structure in innovative ways.

According to the different focuses, I classify the design approaches of membrane-tensegrity structures into the systematic and continuous design of membrane-tensegrity, and the additive and modular design of membrane-tensegrity. In this thesis, the goal tends to be observing the behaviors of elastic membrane during the tensegrity form-finding process as a tension member, as well as the possible geometric results generated after the force equilibriums have been reached between the elastic fabric and the rigid linear struts. Thus, the method of systematic and continuous design of membrane-tensegrity will be applied in the following design.



Fig. 39.  
*MOOM pavilion.*



Fig. 40.  
*Underwood pavilion.*

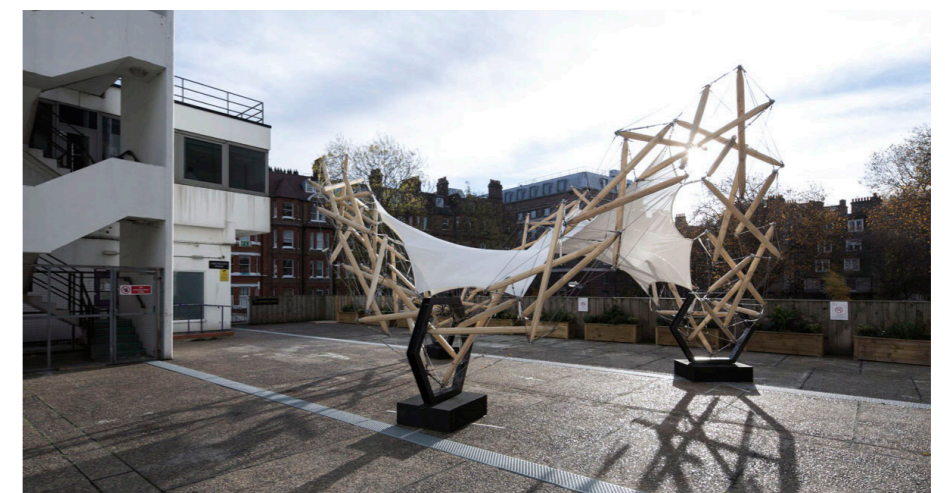

Fig. 41.  
*Tension pavilion.*

## 2. Modular geometry repetition.

Practically, in order to apply the developed generic digital tool into an interactive architectural design process, firstly and the most importantly, is to construct the initial structural form logically. As a starting point of design as well as the initial geometry fed to the computational algorithm, the pre-defined initial structural form determinate the final results directly. Consequently, optimized digital geometries tend to promote the design and compute process enormously. To obtain a relatively complicated spatial geometry that potentially exhibits various vivid spaces as the initial architectural form; a singular geometry could be adapted to start with. The singular geometry would be defined as a standard module with same properties that could be repeated infinitely with a well-defined pattern or along the pre-defined paths. In this way, the modular geometry, with a spatial volume, tend to grow in three dimensions freely and logically. Therefore, the eventual complicated geometry, with a recognizable structural pattern and plenty of hierarchical interior spaces, is quality enough to be applied to construct the corresponding membrane-tensegrity structures with the generic digital tool.

Here, I chose an archetype form of tensegrity, the tetrahedron, as the initial singular module to start the experiment. Besides, instead of a defined pattern, the tetrahedron module would grow along the indicated paths designed by architects. As a result, the populated tetrahedron complex would be a discrete approximation of the final shape; it allows for fast and flexible design with simple building blocks and through tensegrity relaxation afterwards for refinement (Fig. 42)

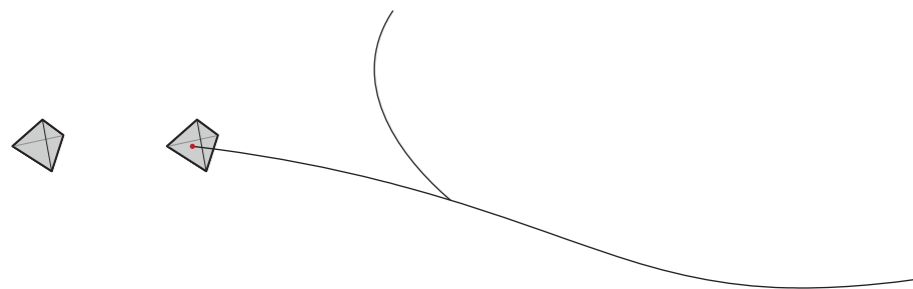

Fig. 42.  
Tension pavilion.

To populate the initial module tetrahedron along the given paths spatially, it is necessary to develop an algorithm correspondingly to open more design possibilities with efficiently generate an overall complicated geometry from a tetrahedron. With the algorithm, architects and designers could interactively modify the lengths of paths; paths quantities as well as the paths orientations. Consequently, the final form which is a complex of repeated tetrahedrons would response to the modifications immediately.

As shown in the diagram (Fig. 43), the algorithm utilizes basic algebra and vector calculations to create the modular tetrahedrons by a given side length. The inputs are curves which assemble the paths to populate and the side length of the tetrahedron. Firstly, the function starts by making an initial tetrahedron module on the start point of the first curve. Three tetrahedron base points are created on the world XY plane around the start point with one of the tips pointing away from the curve end as default. This equilateral triangle, serving as the base triangle, is then transformed into a tetrahedron by moving the curve start point or base triangle center point up by the calculated height of the tetrahedron.

Secondly, the algorithm would start checking curve and tetrahedron intersections and as it finds an intersection with the previous tetrahedron it will use the intersected tetrahedron face as a new base triangle, and with the face normal vector multiplied by the height making it easy to create the new tip.

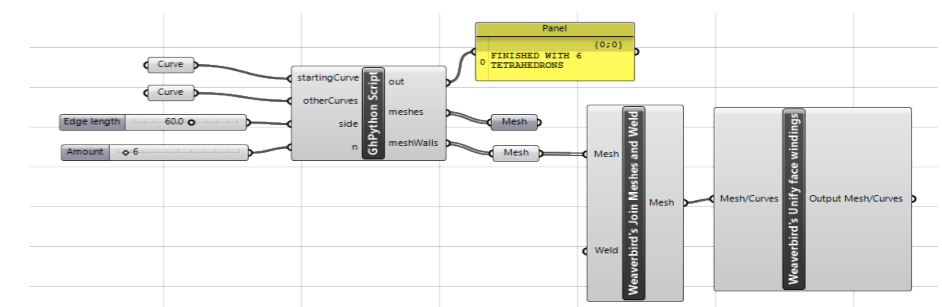

Fig. 43.  
Algorithm of populating  
modular tetrahedron  
along the given paths in  
Grasshopper interface.

Since then, the code proceeds in a straight forward way until it reaches junctions with other curves and where it then creates another instance of population to swarm the other curves as well. This process continues until there is nothing more to populate. Thirdly, as the tetrahedron modules have been populated along the given paths, the overlapped faces need to be demolished to derive a continuous single layer surface with spatial qualities as the final geometry as well as the initial geometry for the generic digital tool of constructing membrane-tensegrity structures.

The diagram below (Fig. 44.) demonstrates the process of populating a modular tetrahedron with the designed algorithm in two different edge lengths. The tetrahedron in left row has edge length as 40 and the one in right row has 20. Growing along the same path, there are 24 tetrahedrons generated in the left with larger volume, while 49 tetrahedrons generated in the right row with more spatial diversities.

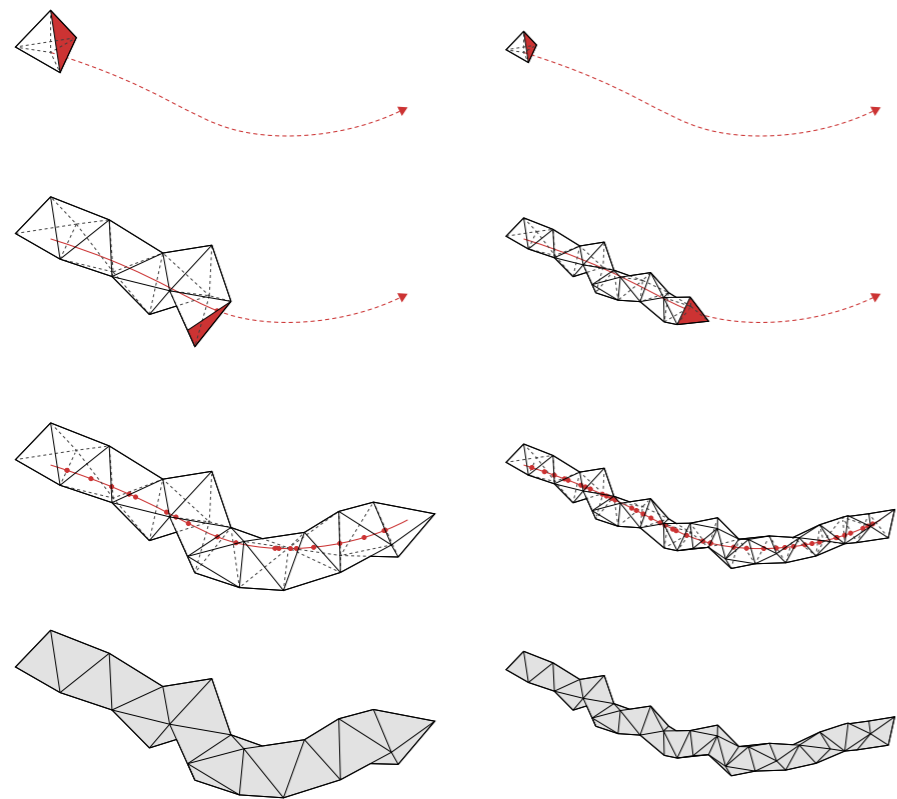

Fig. 44.  
Populating two sizes of modular tetrahedrons along the same path.

Aside from the two introduced possibilities, there are endless geometric results could be generated by the described algorithm, with three defined parameters: pre-defined paths; tetrahedron edge length; and the amount of tetrahedron modules to repeat. As a grid of the generated tetrahedron complexes displayed below (Fig. 45.) although the edge length of all the tetrahedron modules shares the same value, the final geometric forms present enormous differentiations after being repeated along the diverse spatial paths.

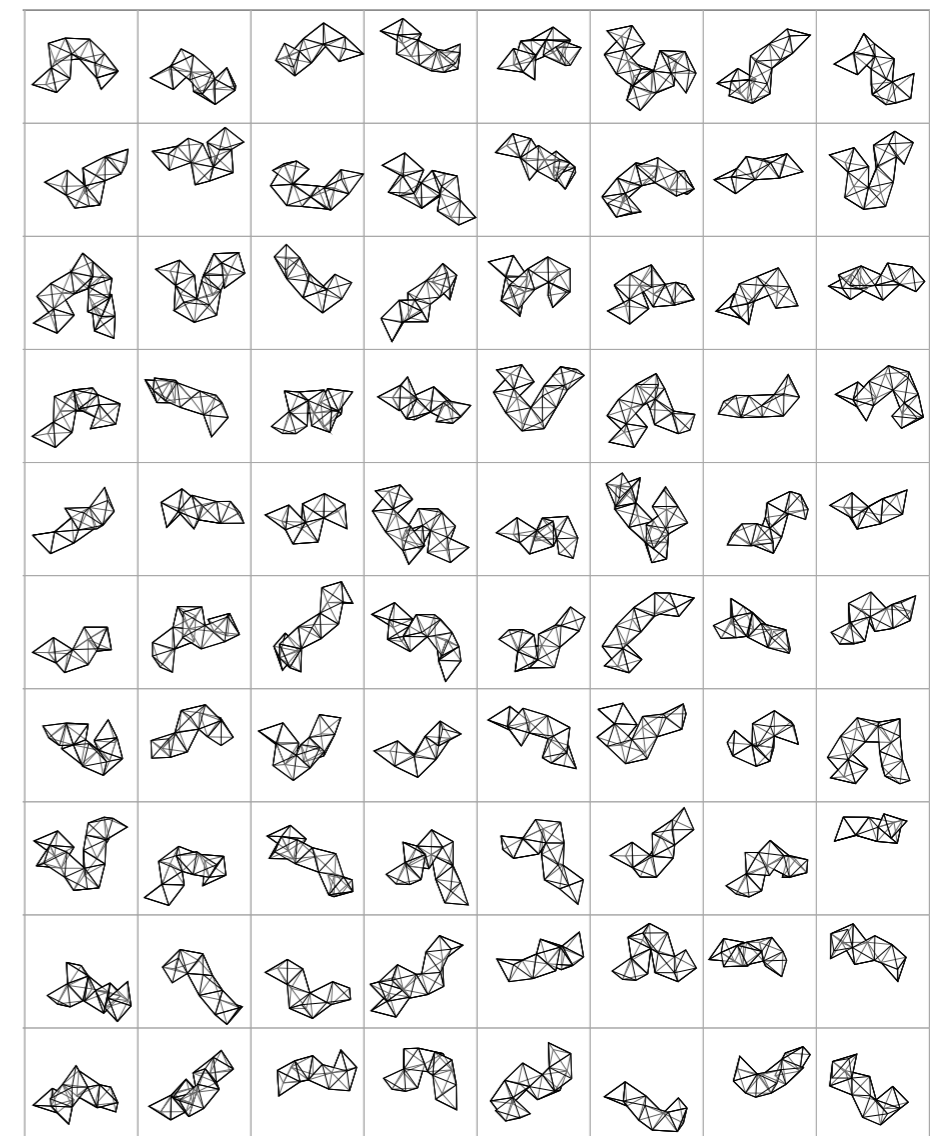

Fig. 45.  
Populating one standardized modular tetrahedron with different paths.

curve average length:  
150  
tetrahedron side length:  
30  
average count:  
16

### 3. Structural speculation of a membrane-tensegrity bridge.

Based on the introduced method, I indicate the potentials of the developed digital tool with a structural demonstrator as a linear bridge structure with two branches, which is generated with modular tetrahedron repetition along two linear and planar paths (Fig. 46.). From the generated spatial modular geometry complex, to the topological strut-cable configuration with membrane surface could be constructed by following Tomohiro's method. Consequently, the form-finding behaviors of the configuration under the functions of multiple forces from internal system and external physical environment are to be simulated accurately.

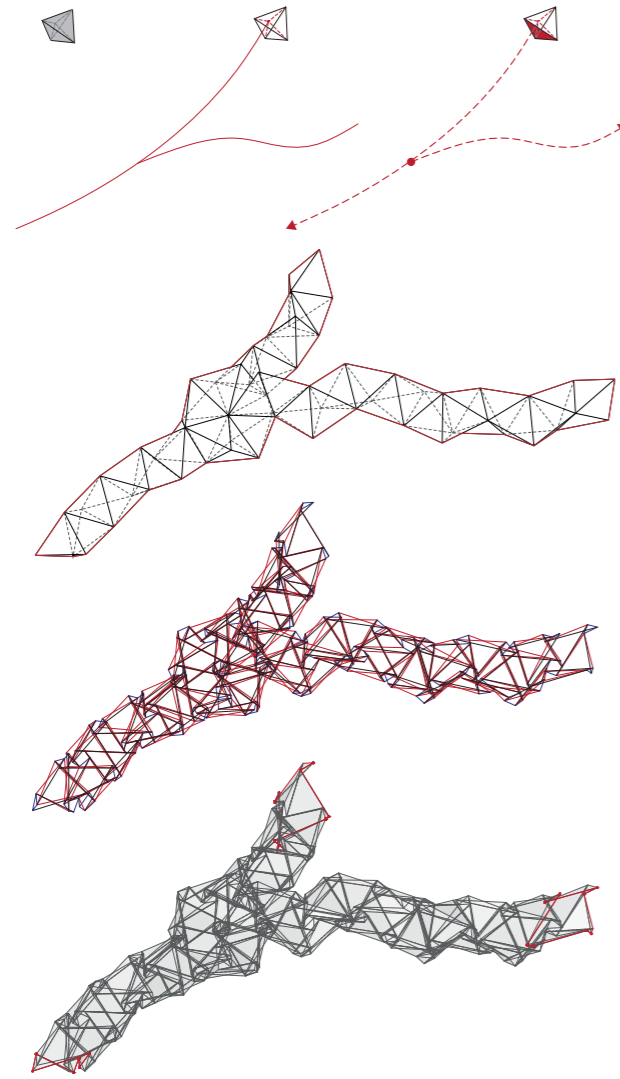

Fig. 46.  
One modular tetrahedron and the defined paths.

Fig. 47.  
Topological transformation from the initial geometry to the strut-cable configuration and the strut-membrane configuration.

The internal forces, which clearly are the continuous tensional force from the pre-stressed membrane and the independent compressional force from the pre-compressed rigid struts.

These two internal forces are the most vital forces and are easily defined by controlling the target lengths values for both elements in simulation. The target lengths values represent the allowance to have the object lengths scaled during the force-balancing process. Based on the material properties, the target lengths values for mesh membrane are always smaller than the initial mesh edge lengths as a result from their bending behaviors yet are always remain the same values for the struts since the bending behavior is too subtle to be considered for the pre-compressed struts. Besides the internal embedded forces, some necessary external forces are to be included to optimize the accuracy of the simulation. Most commonly, the forces from environment are gravity; wind load; and the possible point load from users. To simulate the force digitally, all the pre-defined forces in various types could be directly fed into Kangaroo in Grasshopper in parallel. (Fig. 48.)

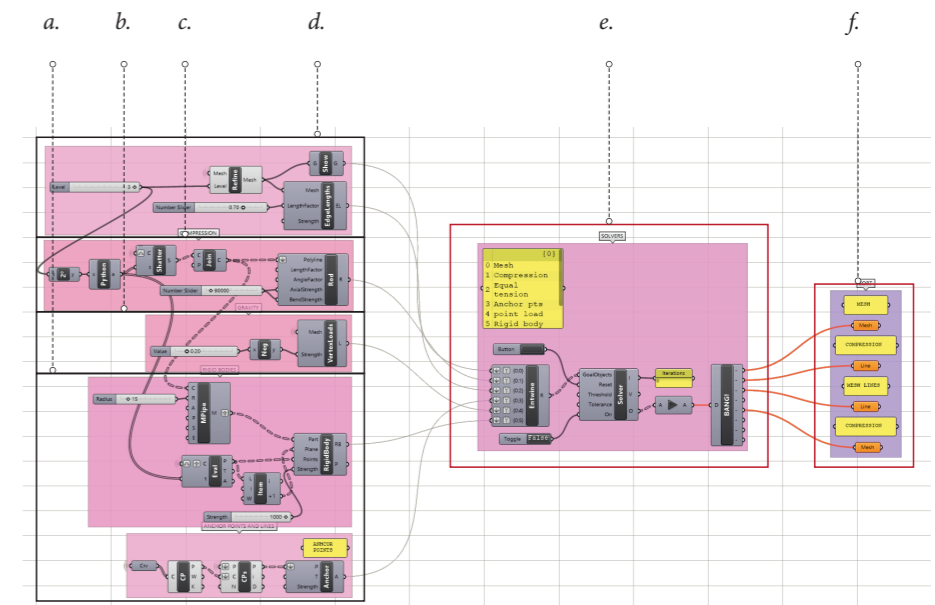

Fig. 48.  
a. Geometric constraints - defined anchor points.  
b. External force value.  
c. Pre-compressed rigid struts.  
d. Pre-stressed mesh elasticity.  
e. Kangaroo solver with all the parameters fed in parallel.  
f. Final structural result.

Except the forces, some optional geometric constrains are helpful for architectural design of membrane-tensegrity structures. For example in the bridge design, as the picture indicates above, the fixed points which will not move their initial positions during the force-balancing process would connect the structure with the ground plane, and therefore result in a more realistic digital simulation.

The force-balancing calculation through Kangaroo reflects on the structural form-finding process by each iteration, as the amount of iterations grows, the progress of self-equilibrium form-finding is visually illustrated. The calculation loop by Kangaroo repeats by iterations until the final force-equilibrium state has been reached, which correspondingly, the final stabilized structural form of membrane-tensegrity is determined.

Here the eventual result of the final bridge structure with a continuous interior path is demonstrated in the axonometric drawing with a list of determined parameter values. (Fig. 49; Fig. 50.) As indicated, there are two optional paths for users, one with more height varieties on the left and another with more flat shape for accessibilities.

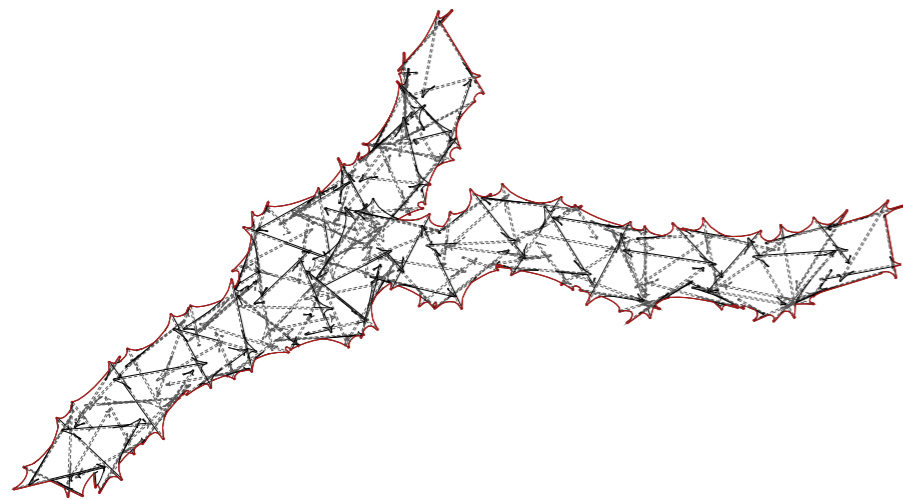

Fig. 49.  
Structural form adapted  
for bridge design.

Struts' length: 1.2  
Struts' rotation: 0.3  
Membrane elasticity  
value: 0.7  
External force: -0.1.

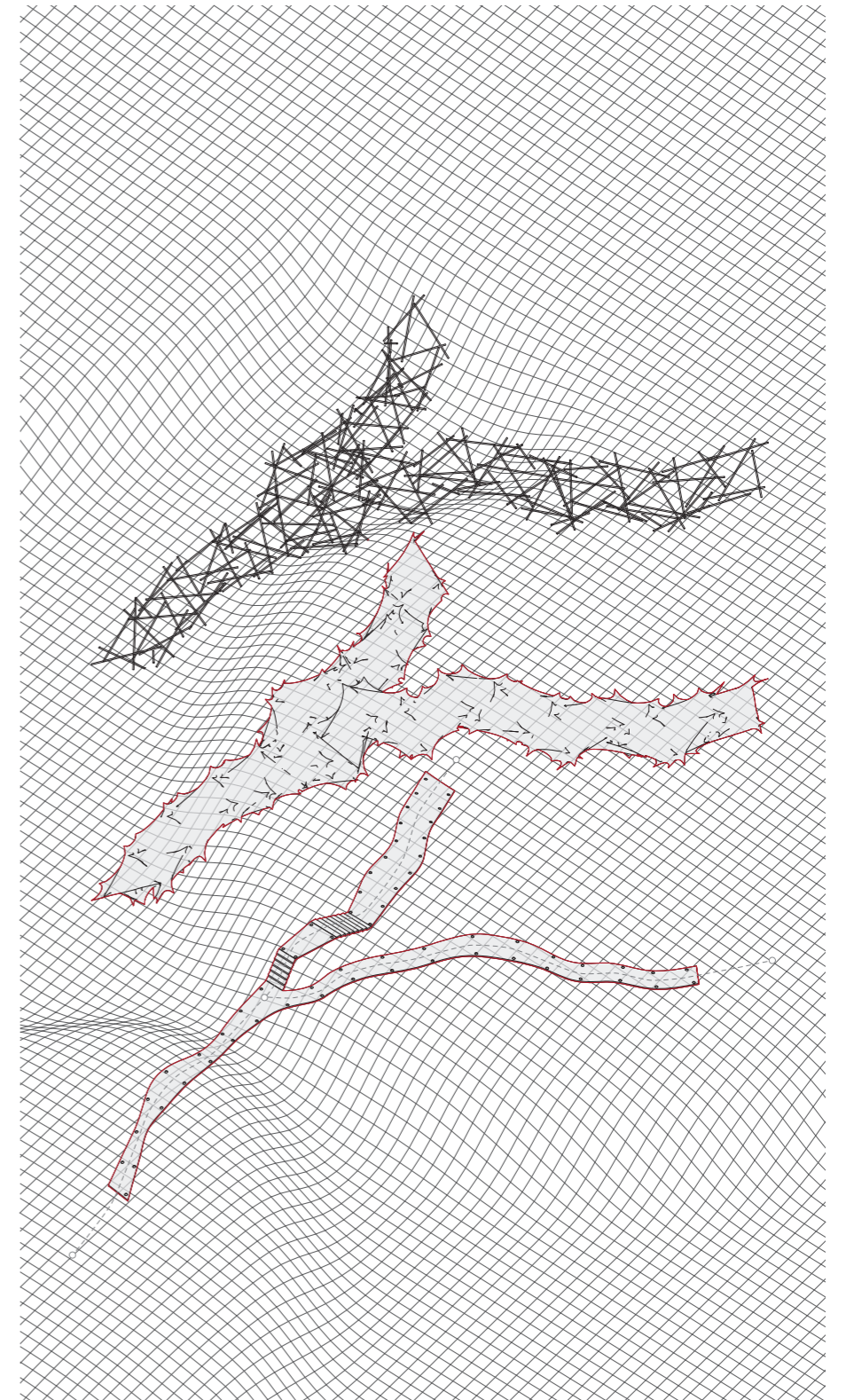
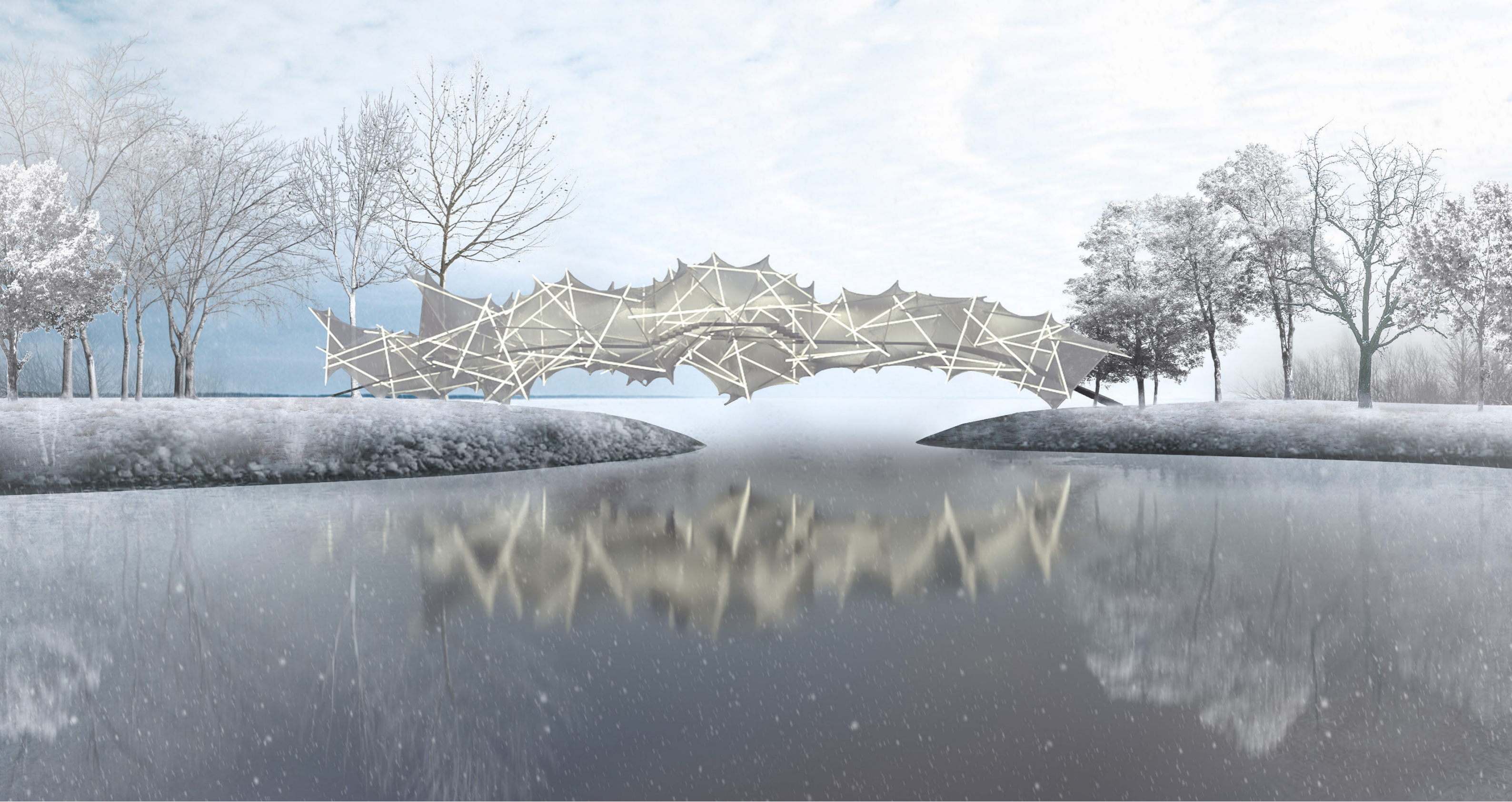
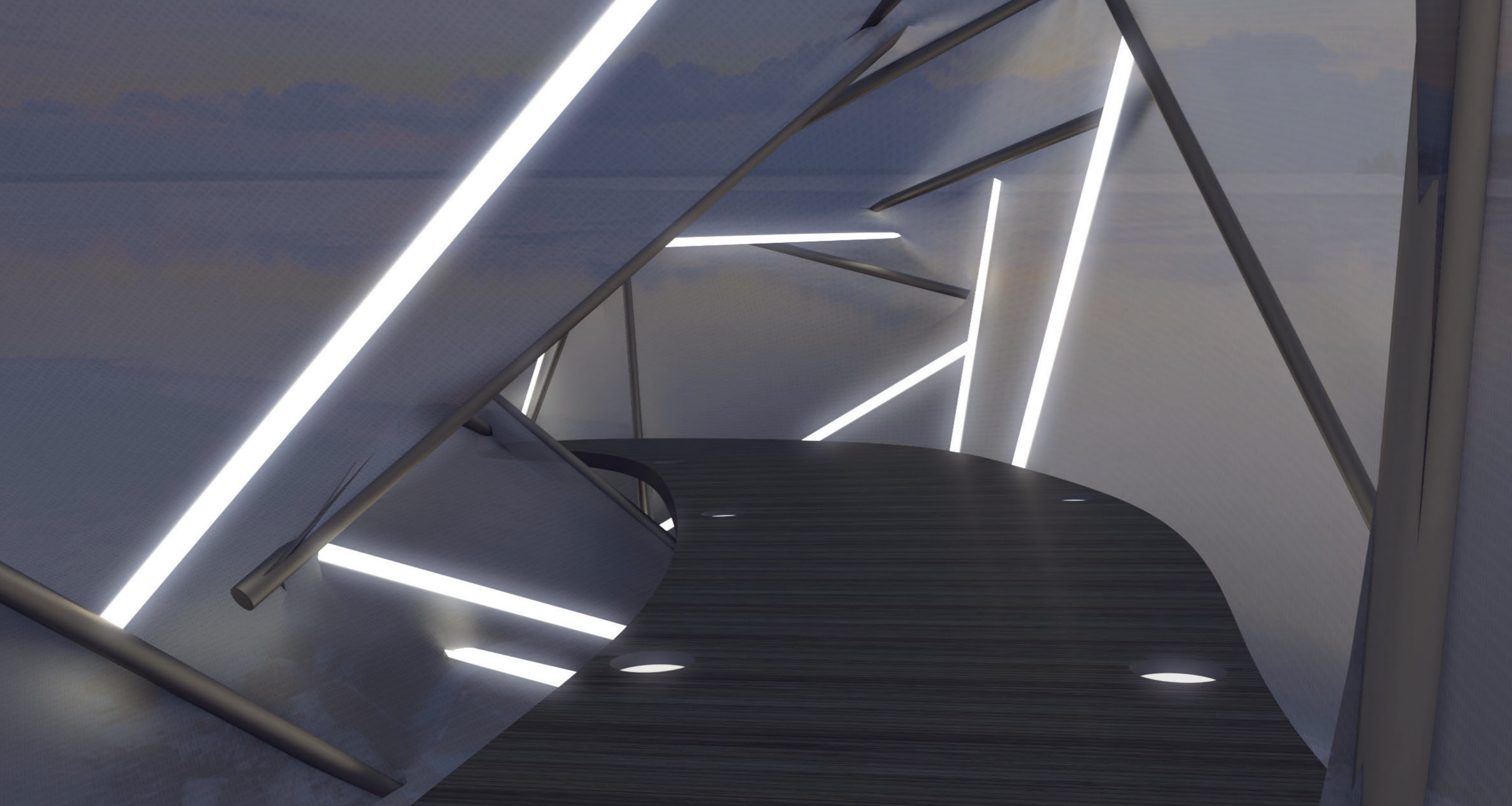

Fig. 50.  
Exploded axonometry  
drawing of the  
membrane-tensegrity  
bridge with the path.







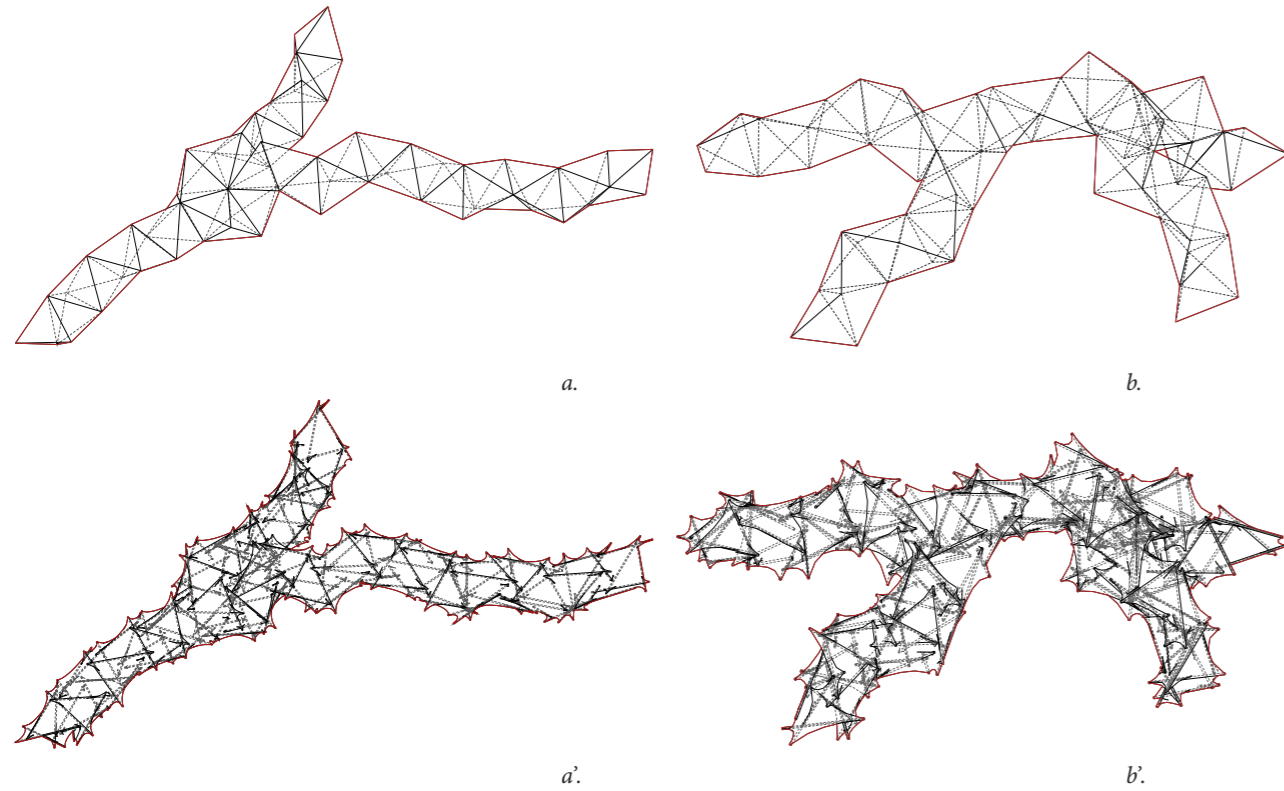

Fig. 51.  
*a. Initial geometry for the introduced bridge design.*  
*a'. Corresponding membrane-tensegrity structural result.*  
*b. A completely different initial geometry.*  
*b'. Corresponding membrane-tensegrity structural result.*

Nonetheless, the structural result of the membrane-tensegrity bridge is not unique. Having started with the same initial geometry as well as the same strut-membrane spatial configuration, the eventual structure forms vary after the force-equilibrating and form-finding process with various defined values for parameters. There are influential parameters for the bridge structures according to the described generic algorithm, which are the initial geometric form; struts lengths; struts rotation angle; membrane elasticity; anchor points; and the abstracted external force value.

As the comparable examples displayed in the diagram above (Fig. 51.), an initial geometric form which differs from the introduced shape (Fig. 51. (b), (b')) leads to a completely different membrane-tensegrity structural result through the same process with the same defined values for parameters.

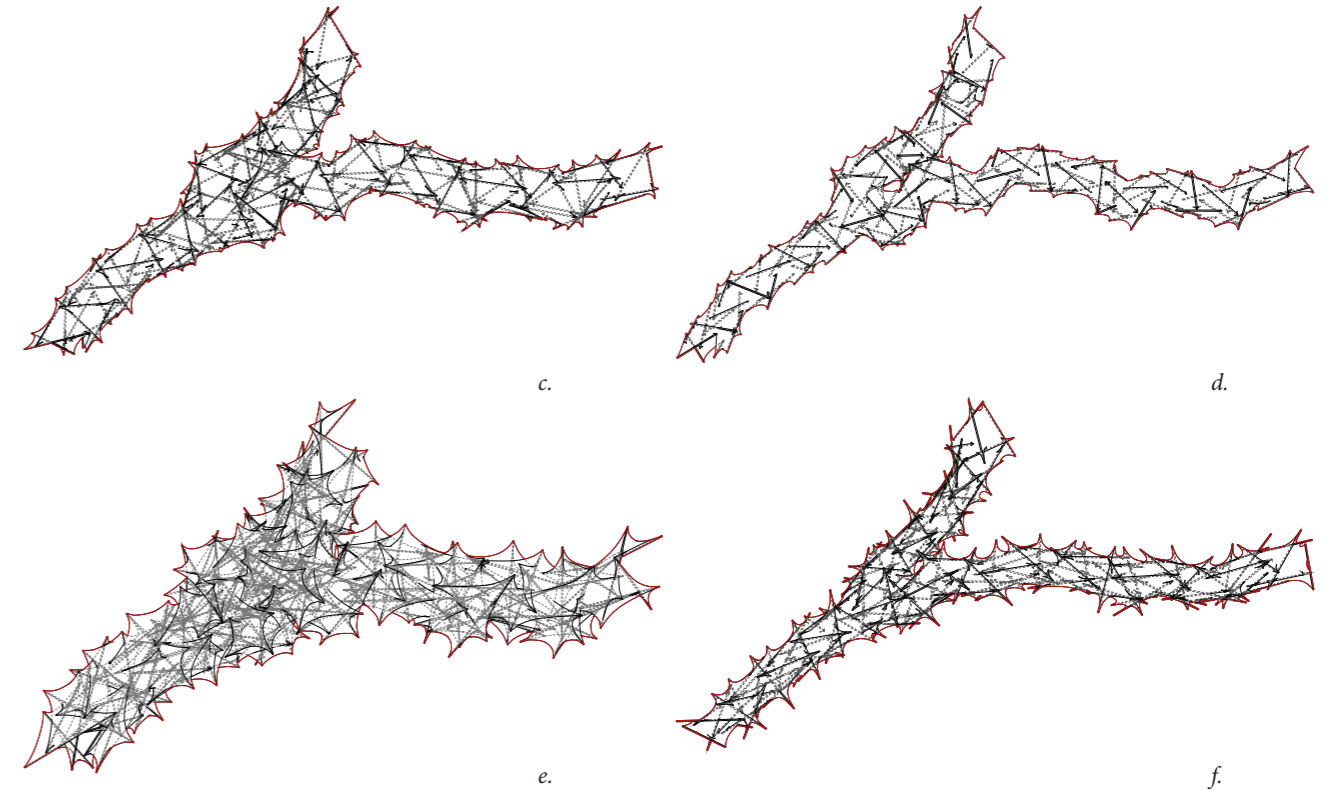

Fig. 52.  
*c. Adapted structure.*  
*d. Comparable case 01, with smaller struts' length and bigger rotation angle.*  
*e. Comparable case 02, with larger struts' length and rotation angle.*  
*f. Comparable case 03, with smaller membrane elasticity value.*

Yet, remaining the same initial geometric form to start with, the diagram above (Fig. 52.) indicates more possible membrane-tensegrity structural results with the granted parameter values differing from the adapted values in the design of the bridge structure.

Nevertheless, the modular geometries are not limited into a simple tetrahedron or platonic solid geometries. Theoretically, any freeform geometry could be applied as the initial module for generating a more complicated geometry which contains more spatial variates. Thus, architects could start designing freeform membrane-tensegrity structures through the method of modular geometry repetition to form the initial structural form. Afterwards, the developed digital tool would simulate the force-equilibrating process and present the possible structural results with the controllable parameters.

#### 4. Surface manipulation.

Referring back to MOOM pavilion, the structure is originally transformed from the spatial pattern of Waterbomb tessellation origami, which is a single-layer folded surface, as the initial geometry for the membrane-tensegrity relaxation. Remaining while extending the same approach of constructing the initial geometry, a single-layer freeform surface would be a well-defined initial geometry after the introduced manipulations in the following paragraphs.

Fundamentally, there are multiple geometric preferences on the initial single layered geometry to optimize the final structural form as well as to avoid the possible runtime error in the coded Grasshopper definitions which developed based on the generic algorithm. Here I propose three geometric preferences on freeform surfaces as well as their corresponding operations for optimization.

1. The digitally built freeform surface, no matter close or open; planar or spatial, should be transformed into a mesh geometry, since the mesh geometry contains all the topological information. After that, the corresponding triangulated mesh is required to keep every single mesh face as triangle, which means the facet value of the mesh for the following topological closed loop generation always equals to 3. In this way, the calculation of generating the facet-corresponding closed loop cable connections is efficiently simplified after the facet value is unified (Fig. 53.).

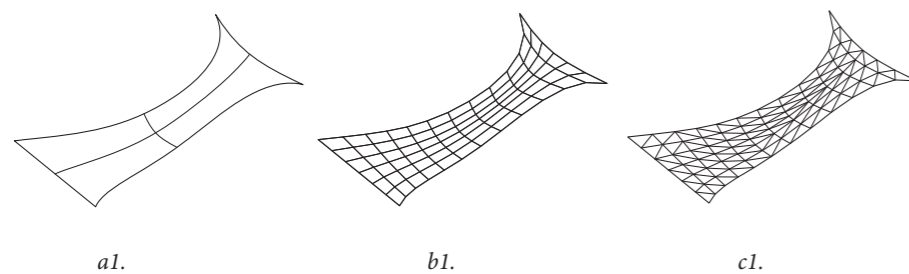
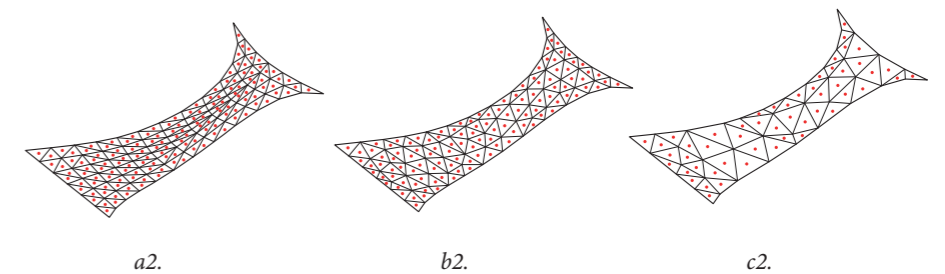

Fig. 53.  
a1. A freeform surface.  
b1. Transformed mesh surface.  
c1. Triangulated mesh surface.

2. Once the freeform mesh geometry has been triangulated, it is common that the edges lengths of individual triangles various depend on the local curvatures as well as the UV count. However, to enhance the accuracy of generating the valency-corresponding closed loop cable connections for the topological configuration, it is preferred to standardize the edge length of each triangle, since the method of constructing the loop is finding and connecting the closest points among all the neighbor points of each vertex after the mesh edges are rotated. The triangulated mesh geometry therefore should be interactively re-meshed in which way the existing mesh edges tend to be scaled, rotated and flipped depend on the defined edge length.

Fig. 54.  
a2. Triangulated mesh with center points on mesh faces.  
b2. Re-meshed surface with a defined standard edge length.  
c2. Reduced mesh surface after b2.



3. When the triangulated and re-meshed mesh geometry is prepared, the initially designed geometry is quality enough to be applied into the developed digital tool for the following generation of the topological strut-cable network. Whereas, to decrease the computation work load as well as to simplify and clarify the appearance of the final membrane-tensegrity structure, it is preferred to reduce the amount of mesh faces while remain the geometric shape. If the edge lengths of the reduced triangular mesh faces differ dramatically, re-meshing the whole mesh geometry with a given edge length value is necessary.

Moreover, there are additional operations to make the fine mesh more locally designed depends on certain circumstances or architects personal aesthetic preferences. In my experiments, I explored two methods, which are re-shape the prepared mesh geometry via attractor

points influencing the lengths of triangular mesh edges; and sub-divide the existing mesh faces by adding pyramids spatially on each face with a flexible value of distance given by architects. (Fig. 55.)

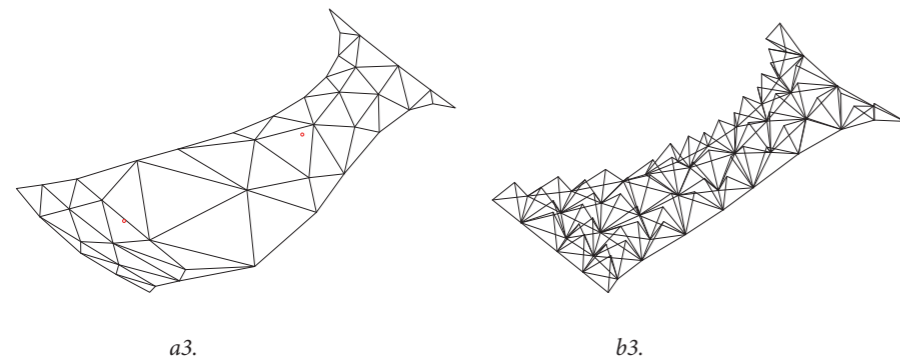

Fig. 55.  
a3. Re-shaping the manipulated mesh surface via attractor points.  
b3. Subdivided mesh surface.

In conclusion, an arbitrary freeform and single layer surface designed by architects or designers could be served as a fine initial geometry to start with, when it has been triangulated and re-meshed to obtain standard edge length as well as been optionally reduced the weight of face numbers. Worth mentioned, the preparation of the quality initial geometry is highly interactive with designers and architects since each step of manipulating the mesh geometry presents as a design decision which influences the final geometric appearance enormously, and the required parameters, for example mesh edge length; mesh face number; as well as the additional mesh re-shape, are determined by architects. Owning a flexibly designed and well-manipulated mesh surface, the basis for constructing membrane-tensegrity structure is settled.

## 5. Structural speculation of a membrane-tensegrity pavilion.

Based on the proposed surface manipulation method, here I propose a conceptual design of a membrane-tensegrity pavilion in order to experiment the structural transformation from an arbitrary spatial and single-layer surface to a completely self-standing membrane-tensegrity architecture with certain geometric constraints.

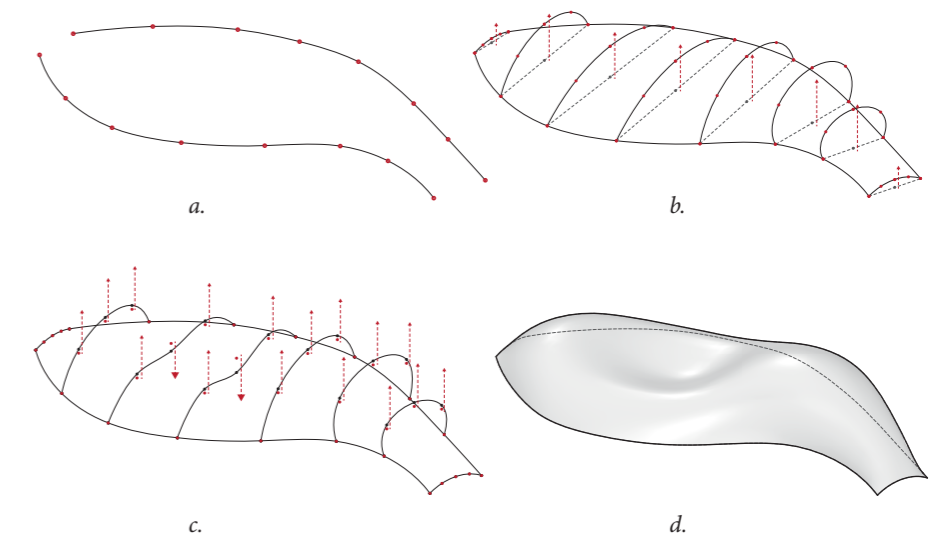

Fig. 56.  
Process of constructing a controllable freeform spatial surface.

To construct a controllable freeform spatial surface, I started with constructing two NURB curves which define the boundary of the spatial surface (Fig. 56 (a)). The curves are interpolated by two sets of points, with manipulating the positions of the points, the initial curves could be interactively controlled. Thereafter, a set of arcs could be constructed by lifting the middle points up in a set of defined values. The arcs along with the two initial curves consist the skeletal composition of the goal surface. (Fig. 56 (b).) In order to create a sequence of diverse spaces inside the continuous spatial surface, the positions of the points on arcs have been moved up and down in a pre-defined height range. (Fig. 56 (c).) With the surface skeleton constructed, a corresponding NURB surface could be lofted smoothly. Thus far, a freeform single layer and continuous surface has been logically constructed. (Fig. 56 (d).)

It is evident that the constructed smooth NURB surface presents one continuous interior space with various heights to set up diverse spatial identities as well as a variety of spatial experiences. The introduced method of surface manipulations could then start with the surface. As shown in the diagram, (Fig. 57.) the simple spatial surface could be easily transformed into a quality mesh with defined UV accounts, after which the simple mesh is triangulated with the similar sizes of individual triangle mesh face. To adapt the mesh surface as the initial structural form, an opening is necessary to be defined to function as the entrance of the final pavilion structure.

Eventually, with the approach of extruding spatial pyramids on each triangular face by a defined value, the single layer surface turn to be more spatially dynamic.

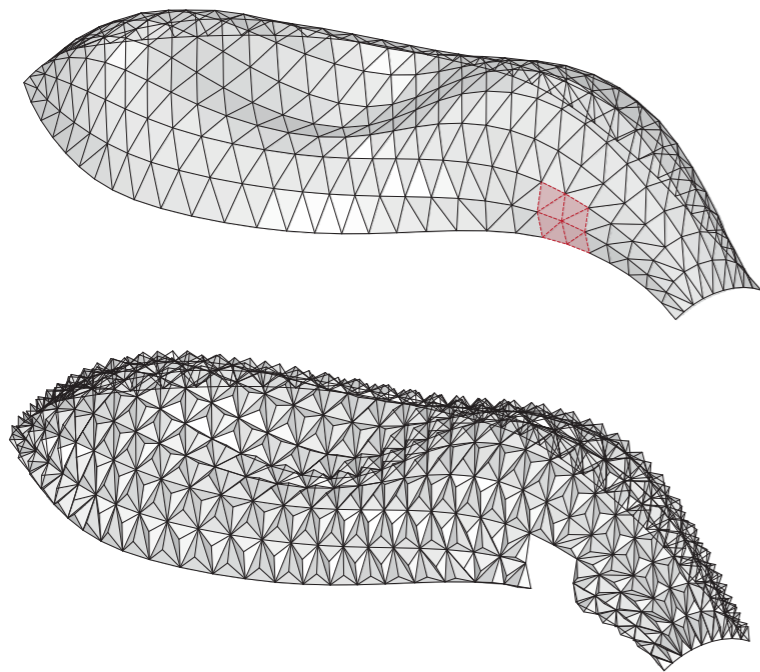

Fig. 57.  
From top to bottom,  
A manipulated mesh  
surface with the opening  
marked in red.  
The constructed initial  
structural form for  
membrane-tensegrity  
pavilion.

Through the same process as the design of bridge structure, the strut-cable topological configuration as well as the corresponding strut-membrane configuration are generated by applying the same digital tool with different defined values on struts length; struts rotation angle; membrane elasticity; gravity factor; as well as the positions of the anchor points. Like presented in the diagram (Fig. 58.), the transformed strut-membrane configuration remains the same topological pattern as the initial mesh surface.

The pre-compressed and the pre-stressed members are therefore composed, along with gravity factor as well as the defined anchor points, Kangaroo solver eventually present the equilibrium structural form after thousands of iterations.

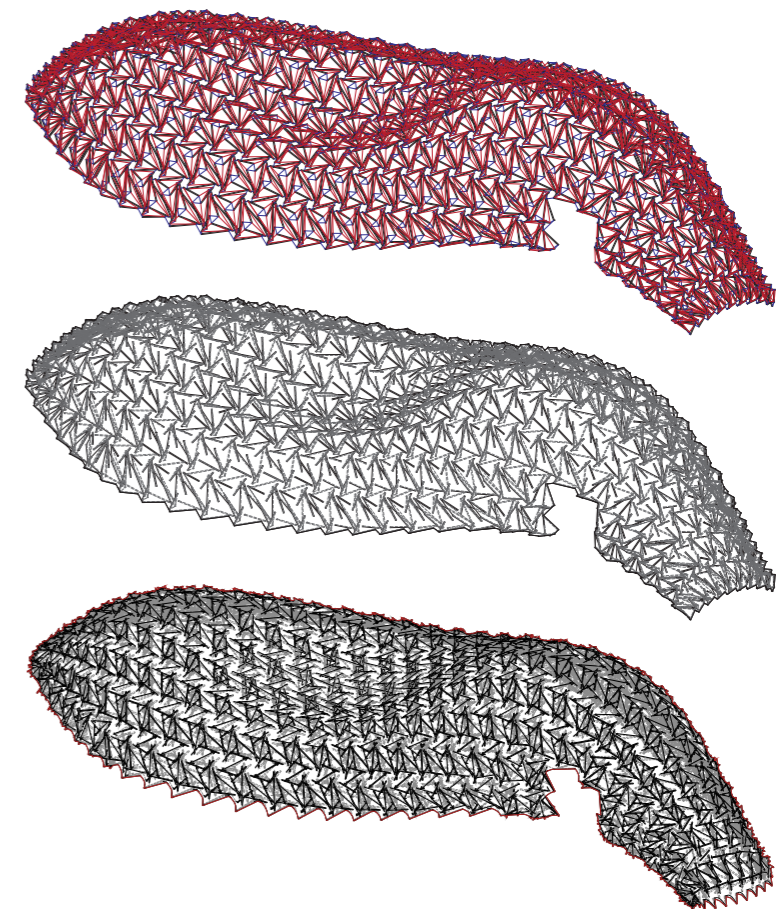
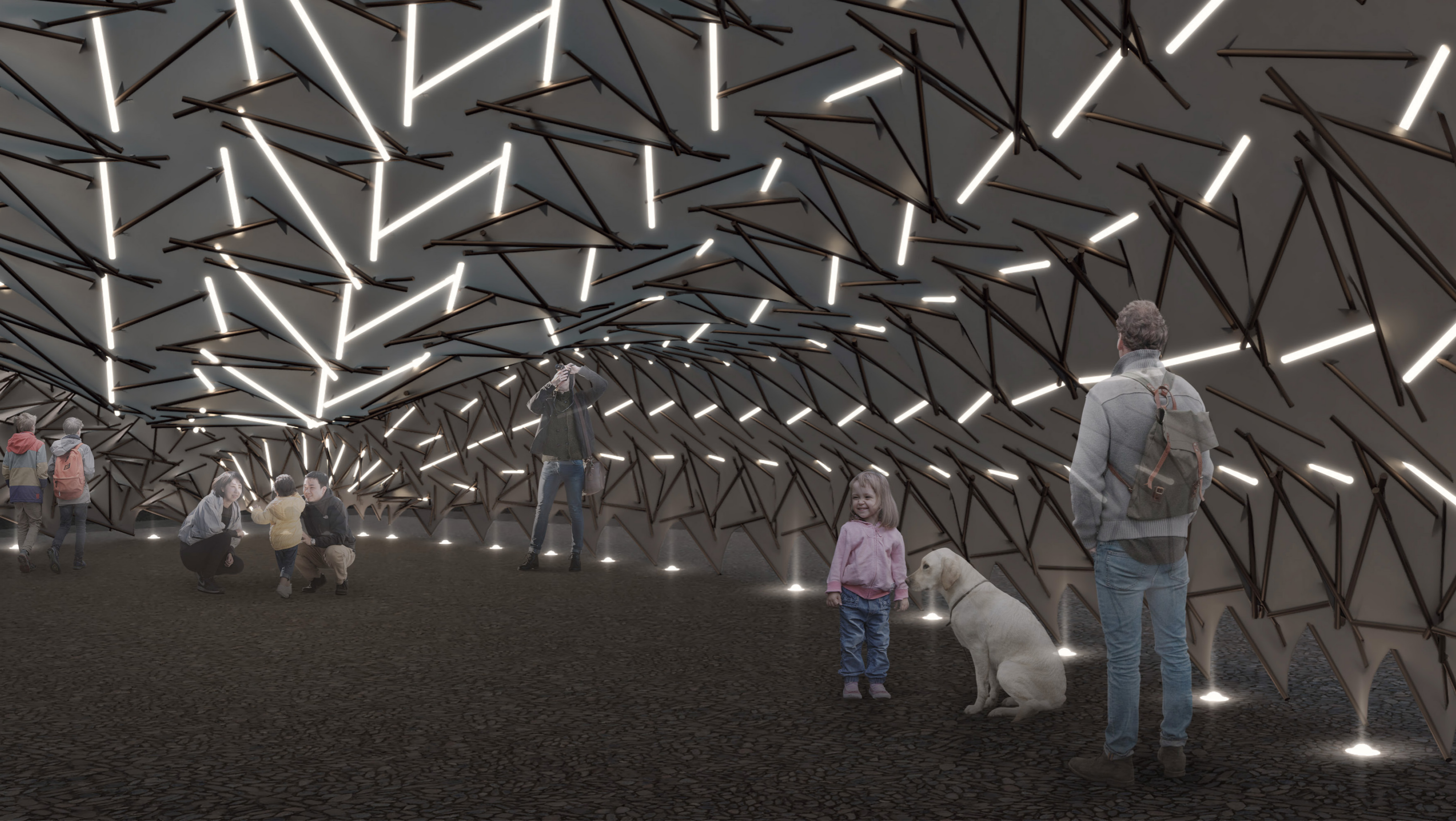

Fig. 58.  
From top to bottom,  
Strut-cable topological  
configuration  
transformed from the  
initial mesh surface.  
Strut-membrane  
topological configuration.  
Final structural result  
of membrane-tensegrity  
pavilion.







Nonetheless, the presented pavilion structural form and its interior space above are not unique. With the interactive modifications on the input values of the selected parameters, the solution space tends to be continuously changing before the final design decisions have been decided.

The diagram below (Fig. 59.) demonstrates more possible structural results based on the diverse input values from the constructed initial surface to the defined parameters and thus result in the corresponding changes on the final structural forms. The presented comparable examples are divided into three groups, illustrating a sequence of different structural solutions. The first two images indicate an absolutely different result by adapting a divergent initial mesh surface constructed with the same manipulation approach. Besides, the rest of the images present the differentiations of the eventual membrane-tensegrity structural forms with various parameter values on the same constructed initial mesh surface.

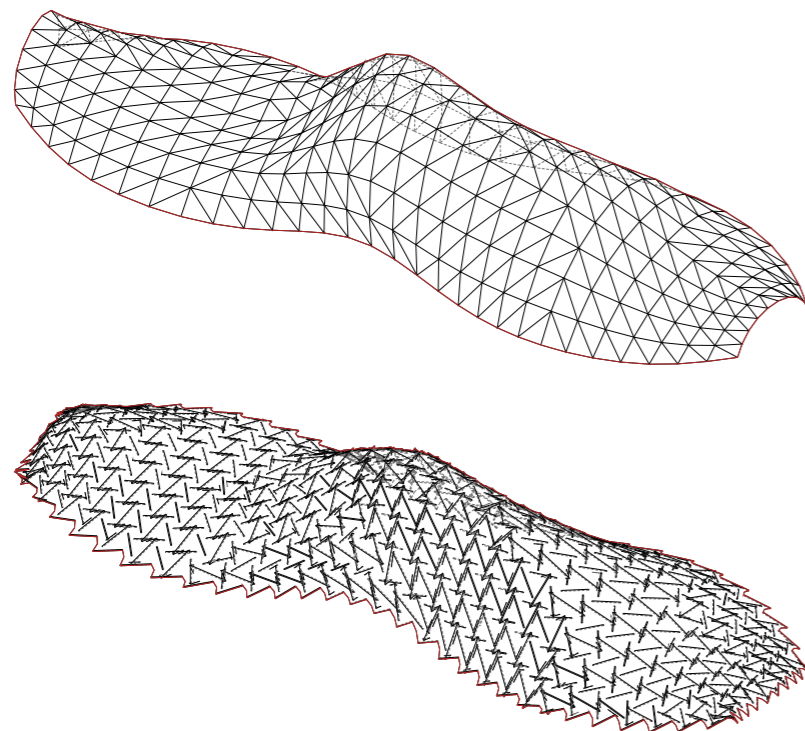

Fig. 59.  
Comparable case 01.  
From top to bottom,  
A completely different  
initial geometry.

Corresponding  
membrane-tensegrity  
structural result.

Parameter values:  
struts' length: 0,9  
struts' rotation: 0,4  
membrane elasticity: 0,5  
gravity factor: 0,2

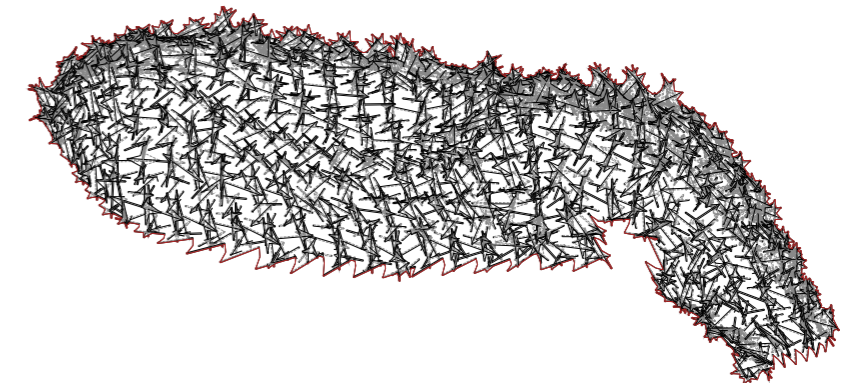

Fig. 60.  
Comparable case 02.  
struts' length: 1.2  
struts' rotation: 0.6  
membrane elasticity:0.25  
Gravity: 0.2  
The final structural form  
performs larger and  
more spiky.

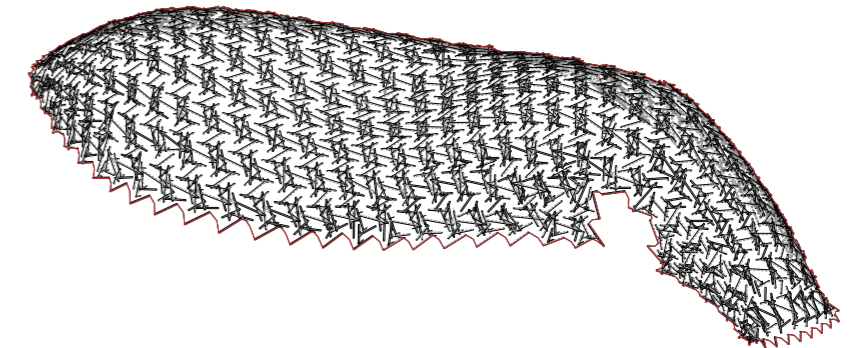

Fig. 61.  
Comparable case 03.  
struts' length: 0.8  
struts' rotation: 0.3  
membrane elasticity:0.25  
gravity: 0.2  
The final structural form  
performs smaller and  
more smooth.

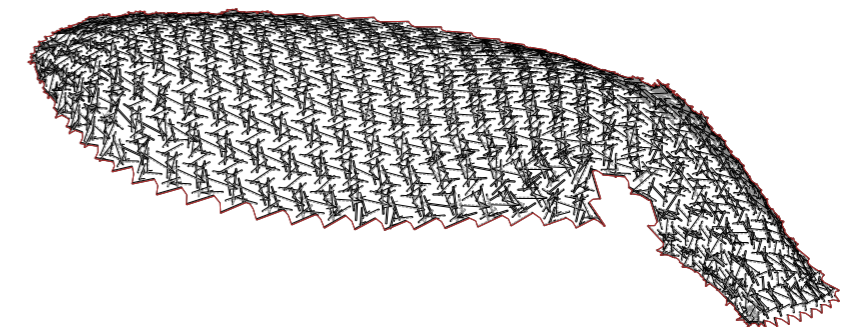

Fig. 62.  
Comparable case 04.  
struts' length: 0.8  
struts' rotation: 0.3  
membrane elasticity:0.25  
gravity: -1.0  
The final structural form  
performs more flat.

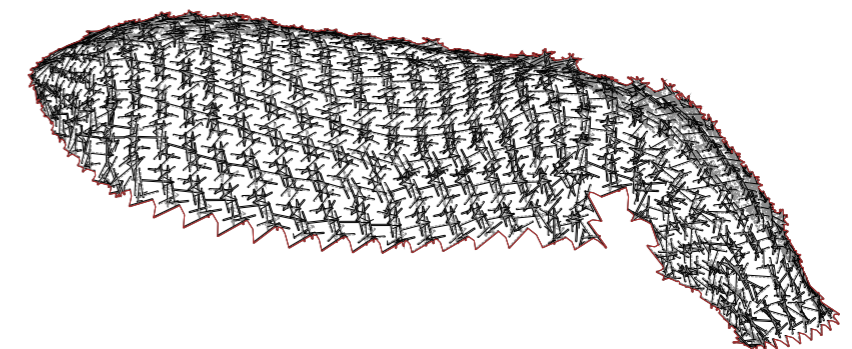

Fig. 63.  
Comparable case 05.  
struts' length: 0.9  
struts' rotation: 0.4  
membrane elasticity: 0.1  
gravity: 0.2  
The final structural form  
performs tighter.



## Conclusion

The research study of this thesis has been firstly triggered by a specific built architecture, MOOM pavilion. After abstracting and analyzing the force distributions in the overall structure, a relatively new structural type behind, tensegrity, has been revealed. Since then, the study is concentrated on acknowledging tensegrity and its structural philosophy. Forward from the classic tensegrity structures, an extended composition of tensegrity structure is proposed as membrane-tensegrity, with a continuous elastic membrane substitutes all the local cable connections in between the discrete rigid rods. Based on the structural principle as well as a generic algorithm proposed in the article “Interactive Freeform Design of Tensegrity”, a corresponding digital tool is developed digitally in Rhinoceros 3D and Grasshopper interfaces with their specific functions. The generic digital tool, which is a successful transformation from the written theoretical algorithm to a computational expression, with the real-time graphic presentations in the program interface by each digital manipulation (chapter II). It frees the limitations to construct tensegrity as well as membrane-tensegrity structures from pre-defined abstract geometries to freeform spatial geometries, and opens plenty of possibilities into creating new architectural structures and spaces with membrane-tensegrity structural type.

Moreover, since the relative knowledge on tensegrity and membrane-tensegrity, as well as the digital experiments on the diverse behaviors of two structural elements, result from multiple force interactions are accumulated, I started to experiment various approaches to apply the abstract digital algorithm to design and construct generic digital membrane-tensegrity structures with possible geometric constraints from the physical environment.

Inspired by Kenneth Snelson’s successful experiments on creating a diverse library of tensegrity sculptures in mostly small-scale modules. The sculptures in larger scales are mostly aggregated via repeating the

same smaller scale tensegrity modules which are originally transformed from the basic polyhedrons. I experiment the first design approach of constructing a well-defined initial structural geometry with modular geometry repetition. To clarify and simplify the repetition process as well as the following membrane-tensegrity transformation process, I adapt a tetrahedron as the basic module and populate the singular tetrahedron to form a relatively complicated spatial geometry via the given paths (chapter IV). The method turns out to be successful for designing freeform membrane-tensegrity structures generically. Therefore, I propose a conceptual design of a bridge structure with two branches. The initial structural geometry is constructed via following the method of modular geometry repetition, thereafter, with multiple values defined for the parameters, a corresponding membrane-tensegrity bridge structure is constructed digitally.

Although the method of modular geometry repetition could guide architects and designers to construct various freeform spatial geometries, it is limited by the basic modular polyhedron. To free the limitation, as well as referring back to MOOM pavilion, the second design approach is to construct a single layer freeform surface with multiple defined manipulations. Thereafter, I propose a conceptual design of a pavilion structure. Same as the first experiment, a corresponding membrane-tensegrity structure could be presented digitally from the manipulated fine spatial surface, through the force-equilibrating process in the algorithm.

Overall, this research study has successfully achieved the development of a generic digital tool for designing freeform membrane-tensegrity structures, combined with two design methods of creating well-defined initial geometries to start with. Hence, the researches bridge the gaps between architectural structure design and the abstract tensegrity principle.

Yet, aside from the achievement, there are some unsolved problems during the wide range of experiments. Digitally, when the force equilibrium state has been reached in the simulation, few compression struts intersect with each other after the compressional curves are piped with certain thickness. To solve the problem, further experiments in Kangaroo, Grasshopper tends to be helpful, since there are designed functions to avoid solid collisions during simulations. Besides, to receive more precise simulated structural results of membrane-tensegrity, additional forces under specific environmental conditions need to be considered, for example, the wind load; rain or snow load; earthquake force, could strongly influence the final outlook of the structure. Physically, the different material properties reflect directly on their behaviors in the overall structure. Thus, it is necessary to develop a further research on materiality of the rigid linear struts and the elastic single-layer membrane. Furthermore, the fabrication process as well as the intelligent work flow of physically constructing a membrane-tensegrity structure is to be discovered.

Finally, worth being mentioned, there are some open questions have been discovered during the whole study process. Digitally, there are other possible design methods of creating the well-defined freeform initial geometries aside from the introduced two approaches could be discovered to enrich more possibilities of constructing freeform membrane-tensegrity structures. Moreover, physically, the possible cooperations between membrane-tensegrity structures and the other structural types or installations would largely extend the structural potentials of membrane-tensegrity structures. For example, the possible combinations between membrane-tensegrity and pneumatic structures could result in more innovative membrane performances and potentially, various struts performances as well. In addition, the composition of membrane-tensegrity structures and the installed sensors would result in the more environmental responsive structures.



## APPENDIX

*In appendix, additional researches about the materiality for two structural elements, strut and membrane, in the proposed membrane-tensegrity structural designs will be introduced. Based on the basic calculation on structural quantities as well as the materiality, the necessary detail designs will be proposed referring to the existing prototypes.*

## Appendix

Here I would introduce some basic quantity calculations on the proposed conceptual designs, to extend the digital design approach to realistic fabrication. Constructing membrane-tensegrity structures from digital calculations and simulations to the corresponding physical structures takes a massive leap, therefore, a logical strategy for fabrication and construction should be necessarily developed as a guidance for the physical construction works. Firstly, the basic structural information as well as the material types should be demonstrated.

Referring to the two design proposal, 169 rigid struts with the same length of 4.80 meters each, and the elastic fabric which is approximately 870 square meters are required for the whole bridge structure, and 2353 rigid struts with the lengths in a range of 0.28 to 1.60 meters and the elastic fabric which is approximately 365 square meters are obligatory for the overall pavilion structure. Although big quantities of the compulsory materials are required, the structures efficiently utilize all the materials with their specialty to stabilize the interactions between forces.

For the membrane-tensegrity pavilion structure, with various strut lengths, constraining the struts with equal length could be considered to enormously promote the efficiency on pre-fabrication. The rigid linear struts, along with the tensional membrane could be simply pre-fabricated before constructing with couple of standard physical values. However, result from unifying the struts length, certain freedom of designing the initial geometry have make compensation. Firstly, all the edge lengths of the initial mesh need to be standardized from the beginning (as the initial geometry applied for bridge structure). Secondly, if the edge lengths on the defined initial mesh geometry vary, the struts lengths should be allowed to be flexibly stretched into a standardized target value during the force balancing actions.

However, in this way, critically, the structure could not be strictly identified as membrane-tensegrity structure since the rigid elements are pre-compressed as well as pre-stressed and present bending behaviors during the form-finding process.

After the basic quantities of the acquired structural elements are calculated, the materiality of the selected architectural materials could be then studied. Although there are mostly two structural elements desired in the overall structure with detail installations, plenty of adaptable materials could be experimented.

For rigid struts, most importantly, the selected materials should obtain enough stiffness to be pre-compressed and to bear the massive internal tension forces generate from every direction by the elastic membrane as well as some possible external forces, in the meanwhile, to avoid bending behaviors during the force-equilibrating process. Beyond that, the material for struts is preferred to be light-weight, aesthetically extraordinary and environmental-friendly. Among all the options, here I would introduce two types of metal materials which are steels and aluminum.

Metal as a type of architectural material has been massively applied into various designs and structures. The most commonly utilized metal includes lead; tin; zinc; iron; copper and aluminum. Each type of the mentioned metal material specializes in different functional field in architecture and structures. Considering about the characteristics of the struts in membrane-tensegrity structures, the iron alloy steel, and aluminum would be preferred. Steel is an alloy mainly of iron and carbon, as a stiff material, it also allows the possible elastic deformation.

Thus, it is ideal for the thin and linear struts in membrane-tensegrity structure compare to concrete and stone which present high-stiffness but extremely low elastic-deformation tolerance when the possible stretch occurs. Besides, its durability and renew-ability are out-standing compared to plastic and wooden materials. Steel does not lose its quality each time it is recycled compared to other recyclable material like plastics. Besides, there are copper-bearing steels, containing 15% to 25% copper to increase the resistance to atmospheric corrosion and result in good-looking brown color.

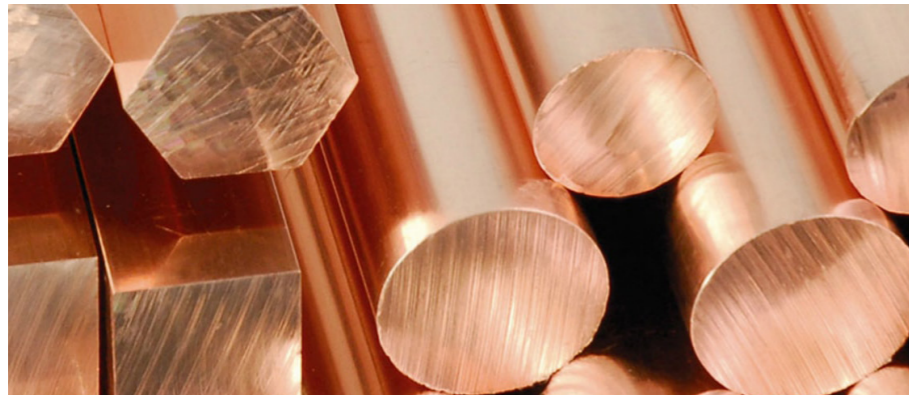

Fig. 64.  
Copper-bearing  
steel rods



Fig. 65.  
Stainless steel rods

However, with plenty of advantages, there are a couple of problems with using steels. First, steel tends to corrode easily in the moist environment without extra anti-corrosive coatings protecting the surfaces. Besides, steel conducts heat and cold well, thus it is not ideal to be exposed without any covers during cold winter seasons in Helsinki. Despite the few weaknesses, steel is one of the preferred material for struts.

Other than steel, aluminum could also be an ideal option. Similar yet different, aluminum is highly resistant to corrosion like copper, and it has the benefit of being a third lighter than steel with comparable strength. Moreover, aluminum could be recursively recycled without losing its quality.



Fig. 66.  
Aluminum rods

For elastic membrane, the materiality directs the force-equilibrating and form-finding process thus orients the final structural forms. As described in chapter II, PVC (Poly Vinyl Chloride) coated polyester cloth and PTFE (Poly Tetra Fluoro Ethlene) coated glass cloth are the most commonly used membrane materials for architecture and structures. PTFE glass is a low maintenance fabric which is superb for large scale and complex structures. It performs more extraordinary than PVC polyester in the perspectives of life expectancy; translucency; fire resistance; as well as thermal insulation and acoustic absorption. Referring to *Architen*, the tensile membranes could be manufactured to virtually any size and shape up to 1600 square meters in a single panel.

The membrane is made up from seam welded sections which are laser-cut into precise patterns. And for single skin PTFE with the thickness from 0.8mm to 1.0mm, it typically weights 1.5 kilograms per square meters. Therefore, based on the basic calculation, the PTFE membrane acquired for the bridge proposal would be approximately 1305 kilograms for 870 square meters and for the pavilion proposal would be approximately 547 kilograms in total for 365 square meters.

Having the structural materials selected, the connections between various materials are to be designed to construct the structures efficiently. In general, membrane-tensegrity structures are relatively not over-complicated to fabricate and to construct since there are purely two structural elements and multiple joint installations are compulsory. On the one hand, the connections between materials determine enormously on functionalities of the pre-stressed and pre-compressed materials thus effect the final geometric results on structures. According to the design proposals of the bridge structure and pavilion structure, there are two types of inherent connections, which are the joints between struts and membrane and the joints between struts and the fixed points pre-defined from the referencing environment.

Interrelations between struts and membrane could be regarded as unarticulated joints since the pattern of the discrete struts on membrane is determined in order to obtain the simulated forms. However, subtle relative motions are permitted in a defined range between struts and membrane in reality. Referring to the same type of internal joints in MOOM pavilion, the designed pockets, which present multiple scales corresponding to the various sizes of struts, sewed on membrane could smartly fix the positions for struts from the determined pattern, with minimum amount of materials, and in the meanwhile simplify the process of pre-fabrication.

Fig. 67.

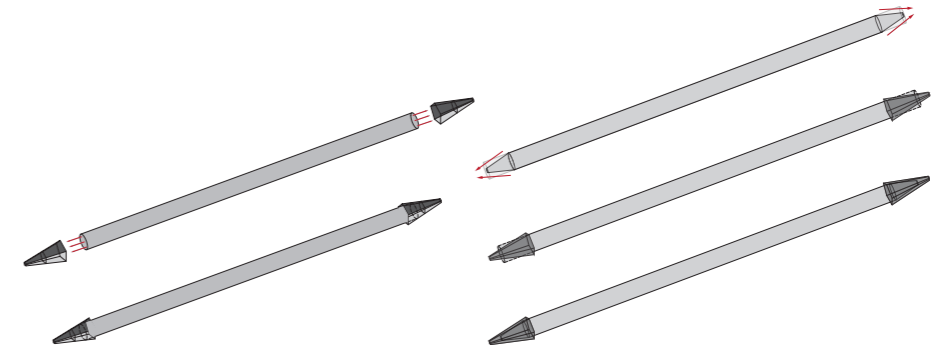

Adapting the design of simple pockets as the unarticulated joints with a tolerant space for relative movement in between struts and membrane result in a decent and humble surface outlook. Diagram in the next page presents a local pattern extracted from the digital simulation of the pavilion proposal. Moreover, in the perspective of material efficiency as well as the tectonic aesthetics, the rigid struts could be possibly function as an inherent ornament on the overall structures besides being solely the compression elements. Here, to match the concept of joint pockets, I propose one possible and simple geometric shape that tends to fit the pockets on membrane.

As shown in the diagram above (Fig. 67.), the endings on both sides of the metal struts could be gradually decreased from a certain defined distance in order to fit deeper inside the pocket. In this way, the influence on struts as rigid elements without bending deformations tends to be subtle. In the meanwhile, the gaps between struts and pockets shrink since the struts could fit better inside. Thus, the relative motions between struts and membrane could be reduced, making the attachment of struts and membrane more accurate.

As yet, with the design of pockets as additional installations attached on membrane, as well as the correspondingly modified form of struts, the internal joint between structural elements is defined.

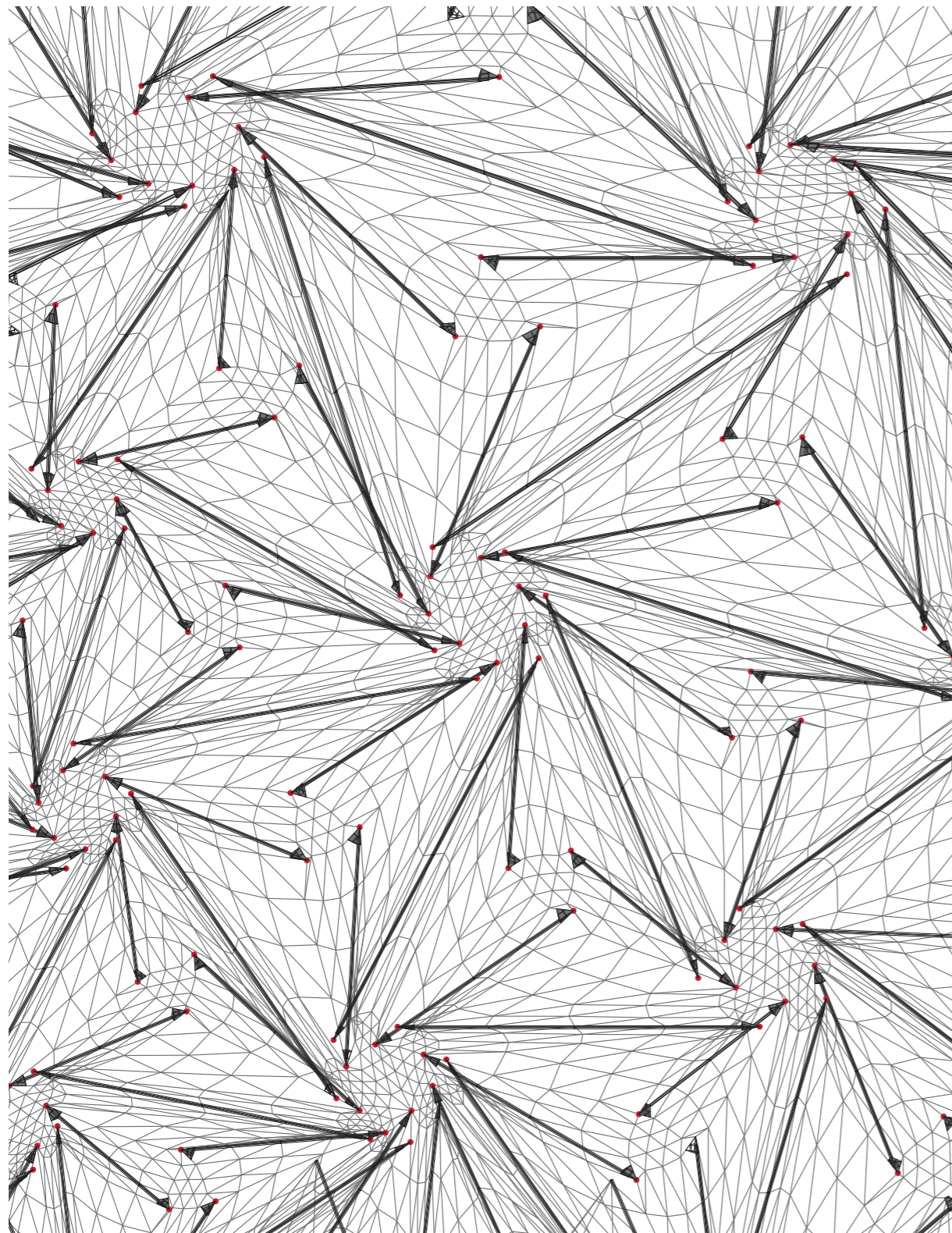

Besides the internal unarticulated connections between struts and membrane, the external connections between the membrane-tensegrity structure and the referencing environment should be considered in the design proposals of bridge and pavilion. Anchor points, which were selected as the fixed joints between structure and the ground plane, bearing the weight of the overall structure and the possible external forces by delivering the forces to the solid ground. The anchor points, in reality, would be represented by a robust installation with a relatively small volume, and the installation would have to be fixed to the solid referencing plane without relative motions in between. To clarify the connections between the anchored installation and the membrane-tensegrity structure, only the bottom rigid struts from structure with equal diameters would directly connect to the installations. Unlike the unarticulated internal connections, the connections between struts and the installations are articulated since the struts are allowed to rotate in any directions from the anchored installations. There are plenty of existing prototypes would satisfy the requirement for the described installation among the ordinary industrial products. Referring to the detail design in *Vanke Tsing Tao Pearl Hill Visitor Center* by *Bohlin Cywinski Jackson*, I propose one possible example of metal installation that attached to the ground and tends to fit locally the connected strut diameters. (Fig. 68.)

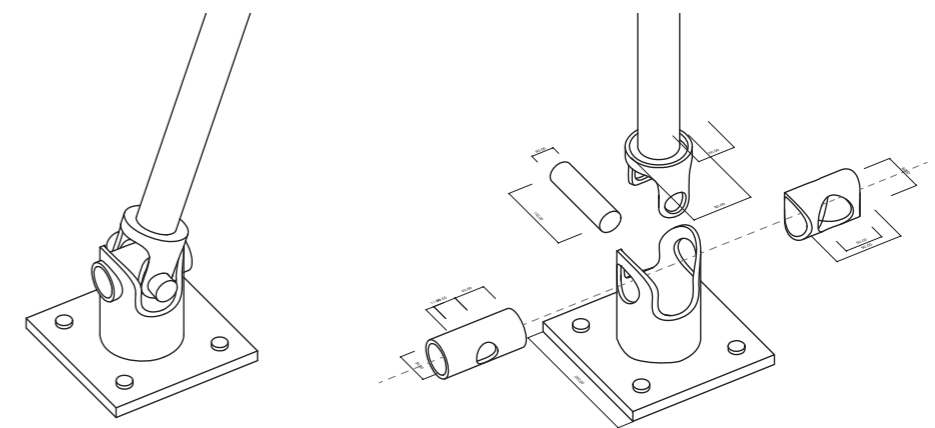

Fig. 68.

## Figure reference

Figure No.	Page		Figure No.	Page	
01	10	DETAIL, 2012, Minimalistic Lightweight Construction: Temporary Pavilion in Noda, DETAIL, Vol. 10/2012	19	24	Snelson, K., 1969, Needle tower II, [Digital photograph], < <a href="http://kennethsnelson.net/sculptures/outdoor-works/needle-tower-ii/">http://kennethsnelson.net/sculptures/outdoor-works/needle-tower-ii/</a> > [Viewed 31 October 2019]
02	11	Senda, S., 2013, MOOM Pavilion, [Digital photograph], designboom, < <a href="https://www.designboom.com/architecture/ca-coelacanth-and-associates-moom-tensegritic-membrane-structure/">https://www.designboom.com/architecture/ca-coelacanth-and-associates-moom-tensegritic-membrane-structure/</a> > [Viewed 31 October 2019]	20	27	Architen Landrell, 2009, The Materials of Tensile Fabric Architecture, [Digital photograph], < <a href="http://www.architen.com/articles/the-materials-of-tensile-architecture/">http://www.architen.com/articles/the-materials-of-tensile-architecture/</a> > [Viewed 31 October 2019]
09	19	The Institute of NeuroPhysiopathology, 2018, NeuroCyto, [Digital photograph], < <a href="https://inp.univ-amu.fr/en/teams/neurocyto-the-neuronal-cytoskeleton-in-health-and-disease">https://inp.univ-amu.fr/en/teams/neurocyto-the-neuronal-cytoskeleton-in-health-and-disease</a> > [Viewed 31 October 2019]	21	27	IbbeOsman, 2018, Roofing Fabric, [Digital photograph], < <a href="http://ibbeosman.me/roofing-fabric/">http://ibbeosman.me/roofing-fabric/</a> > [Viewed 31 October 2019]
10	20	Young, J. Z., 1981, The Life of Vertebrates. 3rd edn. Oxford: Clarendon Press	22	27	Architen Landrell, 2009, The Materials of Tensile Fabric Architecture, [Digital photograph], < <a href="http://www.architen.com/articles/the-materials-of-tensile-architecture/">http://www.architen.com/articles/the-materials-of-tensile-architecture/</a> > [Viewed 31 October 2019]
11	22	Associated Press, 1979, USA Philadelphia Buckminster Fuller, [Digital photograph], < <a href="http://www.apimages.com/metadata/Index/Watchf-AP-A-PA-USA-APHSL29028-USA-Philadelphia-/b678de2801744a59bc74a33c02d6a484/46/0">http://www.apimages.com/metadata/Index/Watchf-AP-A-PA-USA-APHSL29028-USA-Philadelphia-/b678de2801744a59bc74a33c02d6a484/46/0</a> > [Viewed 31 October 2019]	25	34	Tachi, T., 2012, Interactive Freeform Design of Tensegrity, Advances in Architectural Geometry 2012
12	22	Martin, H., 2015, Geodesic Dome, [Digital photograph], Architectural Digest, < <a href="https://www.architecturaldigest.com/gallery/buckminster-fuller-architecture">https://www.architecturaldigest.com/gallery/buckminster-fuller-architecture</a> > [Viewed 31 October 2019]	39	50	Pinterest, 2019, MOOM Pavilion, [Digital photograph], < <a href="https://www.pinterest.jp/pin/557742735088680943/">https://www.pinterest.jp/pin/557742735088680943/</a> > [Viewed 31 October 2019]
13	22	Snelson, K., 2019, X-piece, [Digital photograph], < <a href="http://kennethsnelson.net/sculptures/small-sculptures/x-piece/">http://kennethsnelson.net/sculptures/small-sculptures/x-piece/</a> ; <a href="http://www.tensegriteit.nl/e-xmodule.html">http://www.tensegriteit.nl/e-xmodule.html</a> > [Viewed 31 October 2019]	40	50	Riether, G. & Wit, A. J., 2016, Underwood Pavilion: A Parametric Tensegrity Structure, Advances in Architectural Geometry 2016
14	23	Snelson, K., 2012, The Art of Tensegrity, International journal of space structures, Vol. 27, No. 2 & 3, pp. 72	41	50	StructureMode, 2017, Tension pavilion – lightweight innovative tensegrity structure, StructureMode, < <a href="https://www.structuremode.com/projects/tension-pavilion/">https://www.structuremode.com/projects/tension-pavilion/</a> > [Viewed 31 October 2019]
15	23	Snelson, K., 2012, The Art of Tensegrity, International journal of space structures, Vol. 27, No. 2 & 3, pp. 74	64	88	Tamra, 2019, Bars & Profiles, [Digital photograph], < <a href="http://www.tamradhatu.com/bars-profiles.html">http://www.tamradhatu.com/bars-profiles.html</a> > [Viewed 31 October 2019]
16	24	Snelson, K., 2012, The Art of Tensegrity, International journal of space structures, Vol. 27, No. 2 & 3, pp. 74	65	88	Stainless Steel Overseas, 2019, Stainless steel round bar, [Digital photograph], < <a href="http://www.shinexsteel.com/stainless-steel-ss-round-bar-supplier-mumbai-maharashtra-vadodara-gujarat.php">http://www.shinexsteel.com/stainless-steel-ss-round-bar-supplier-mumbai-maharashtra-vadodara-gujarat.php</a> > [Viewed 31 October 2019]
17	24	Snelson, K., 2012, The Art of Tensegrity, International journal of space structures, Vol. 27, No. 2 & 3, pp. 74	66	89	Impol, 2019, Rods and bars, [Digital photograph], < <a href="http://www.impol.com/products/extruded-products/rods-and-bars">http://www.impol.com/products/extruded-products/rods-and-bars</a> > [Viewed 31 October 2019]
18	24	Math Tourist, 2010, Needle tower, [Digital photograph], Blogspot, < <a href="http://mathtourist.blogspot.com/2010/05/needle-tower.html">http://mathtourist.blogspot.com/2010/05/needle-tower.html</a> > [Viewed 31 October 2019]	68	93	Bohlin Cywinski Jackson, 2012, Vanke Tsing Tao Pearl Hill Visitor Center / Bohlin Cywinski Jackson, ArchDaily, < <a href="https://www.archdaily.com/467061/tsing-tao-pearl-hill-visitor-center-bohlin-cywinski-jackson">https://www.archdaily.com/467061/tsing-tao-pearl-hill-visitor-center-bohlin-cywinski-jackson</a> > [Viewed 31 October 2019]



## Bibliography

- Admin, I., 2015, Designing a Bio-tensegrity Exoskeleton, Interactive Architecture Lab, <<http://www.interactivearchitecture.org/designing-a-bio-tensegrity-exoskeleton.html>> [Viewed 31 October 2019]
- Architen Landrell, 2009, The Materials of Tensile Fabric Architecture, <<http://www.architen.com/articles/the-materials-of-tensile-architecture/>> [Viewed 31 October 2019]
- Bafna, J. & Farkade, J. & Chiou, J., 2018/2019, Digital matter – Tensigrami, Institute for Advanced Architecture of Catalonia, <<http://www.iaacblog.com/programs/digital-matter-tensigrami/>> [Viewed 31 October 2019]
- Bohlin Cywinski Jackson, 2012, Vanke Tsing Tao Pearl Hill Visitor Center / Bohlin Cywinski Jackson, ArchDaily, <<https://www.archdaily.com/467061/tsing-cao-pearl-hill-visitor-center-bohlin-cywinski-jackson>> [Viewed 31 October 2019]
- City of Helsinki, 2019, Helsinki map service, City of Helsinki, <<https://kartta.hel.fi/?setlanguage=en#>> [Viewed 31 October 2019]
- Dimon, T., S 2013, The Organization of Movement, AmSAT Journal, No. 3
- Fritz, S., 2011, The Very Fabric of Architecture: textile use in construction, Architonic, <<https://www.architonic.com/en/story/susanne-fritz-the-very-fabric-of-architecture-textile-use-in-construction/7000625>> [Viewed 31 October 2019]
- Horikawa, J., 2018, Grasshopper Tutorial: Origami Fold using Kangaroo 2, Youtube, <<https://www.youtube.com/watch?v=Fqob5Whr968>> [Viewed 31 October 2019]
- Ingber, D. E. & Landau, M., 2012, Tensegrity, Scholarpedia, <<http://www.scholarpedia.org/article/Tensegrity>> [Viewed 31 October 2019]
- Kluszczyński, P., 2019, Piotr Kluszczyński, Grasshopper3d, <<https://www.grasshopper3d.com/profiles/profile/show?id=PiotrKluszczyński&>> [Viewed 31 October 2019]
- Kojima, K., 2011, MOOM pavilion, C+A Coelacanth and Associates, <<https://www.c-and-a.co.jp/jp/projects/moom/>> [Viewed 31 October 2019]
- Martin, H., 2016, Buckminster Fuller's Geodesic Dome and Other Forward-Looking Architecture, Architectural Digest, <<https://www.architecturaldigest.com/gallery/buckminster-fuller-architecture>> [Viewed 31 October 2019]
- Piker, D., 2012, MeshMash!, Space Symmetry Structure, <<https://spacesymmetrystructure.wordpress.com/2012/09/20/meshmash/>> [Viewed 31 October 2019]
- Piker, D., 2013, New origami example, Grasshopper3d, <<https://www.grasshopper3d.com/group/kangaroo/forum/topics/new-origami-example>> [Viewed 31 October 2019]
- Piker, D., 2014, Dynamic remeshing, Grasshopper3d, <<https://www.grasshopper3d.com/profiles/blogs/dynamic-remeshing-now-with-feature-preservation-curvature>> [Viewed 31 October 2019]
- Piker, D., 2014, Freeform-tensegrity, Grasshopper3d, <<https://www.grasshopper3d.com/group/kangaroo/forum/topics/freeform-tensegrity?commentId=2985220%3AComment%3A1189115&groupId=2985220%3AGroup%3A120977>> [Viewed 31 October 2019]
- Piker, D., 2014, MeshMachine update, Grasshopper3d, <<https://www.grasshopper3d.com/m/blogpost?id=2985220%3ABlogPost%3A1085830&maxDate=2018-11-01T08%3A28%3A26.338Z>> [Viewed 31 October 2019]
- Piker, D., 2019, Kangaroo plug-in, Grasshopper3d, <<https://www.grasshopper3d.com/group/kangaroo>> [Viewed 31 October 2019]
- Piker, D., 2019, Plankton plug-in, Grasshopper3d, <<https://www.grasshopper3d.com/group/plankton>> [Viewed 31 October 2019]
- Ratschke, N. & Bögle, A. & Lindenberg, J., 2017, Parametric Analysis of Tensegrity-Membrane-Structures, IASS Annual Symposium 2017
- Rhino Grasshopper, 2018, Grasshopper Attractor – Weaverbird, Youtube, <<https://www.youtube.com/watch?v=kD7xHcECQ0k>> [Viewed 31 October 2019]
- Riether, G. & Wit, A. J., 2016, Underwood Pavilion: A Parametric Tensegrity Structure, Advances in Architectural Geometry 2016
- Snelson, K., 2012, The Art of Tensegrity, International journal of space structures, Vol. 27, No. 2 & 3
- Snelson, K., 2019, Kenneth Snelson personal website, Snelson, K., <<http://kennethsnelson.net/>> [Viewed 31 October 2019]
- Snelson, K., 2019, Tensegrity, Weaving and the Binary World, [Picture essay], <[http://kennethsnelson.net/Tensegrity\\_and\\_Weaving.pdf](http://kennethsnelson.net/Tensegrity_and_Weaving.pdf)> [Viewed 31 October 2019]
- StructureMode, 2017, Tension pavilion - lightweight innovative tensegrity structure, StructureMode, <<https://www.structuremode.com/projects/tension-pavilion/>> [Viewed 31 October 2019]
- Tachi, T., 2012, Interactive Freeform Design of Tensegrity, Advances in Architectural Geometry 2012
- Tibert, A. G. & Pellegrino, S., 2003, Review of Form-Finding Methods for Tensegrity Structures, International Journal of Space Structures, Vol. 18, No. 4
- Turkhiya, K. & Pankhaniya, K., 2017, Case Study: MOOM Pavilion, Tensegrity Membrane Structure <<https://khushkarstudio.wordpress.com/2017/04/26/case-study/>> [Viewed 31 October 2019]
- Wikipedia, 2019, Architectural metals, Wikipedia, <[https://en.wikipedia.org/wiki/Architectural\\_metals](https://en.wikipedia.org/wiki/Architectural_metals)> [Viewed 31 October 2019]
- Wikipedia, 2019, Tensegrity, Wikipedia, <<https://en.wikipedia.org/wiki/Tensegrity>> [Viewed 31 October 2019]
- Wolfe, A. & Nagda, M., 2012, Interactive Art and Computational Design, <<http://golancourses.net/2012spring/05/09/alex-wolfe-mahvish-nagda-waterbomb/>> [Viewed 31 October 2019]

## **Acknowledgement**

I would first like to thank my supervisor Prof.Dr.Toni Kotnik from the School of Arts, Design and Architecture at Aalto University. Professor Toni Kotnik has been constantly providing helpful suggestions on my researches in each step, from formulating my initial ideas to the final productions and presentations. This thesis study would never be possible to be accomplished in such a short time period without his great help.

I would also like to thank the other experts in ADS research group from Architecture Department in Aalto University, especially lecturer Luka Piškorec. I have received countless inspirations and relative knowledge from their passionate participation and input.

Finally, I must express my very profound gratitude to my parents and my friends, especially to my partner / assistant / therapist / technical consultant Janne for providing me with support and continuous encouragement throughout my studies and through the process of researching and writing this thesis. This achievement would not have been possible without them. Thank you.





