

# The Mathematics Enthusiast

---

Volume 14  
Number 1 *Numbers 1, 2, & 3*

Article 13

---

1-2017

## A Symbolical Approach to Negative Numbers

Paul M.E. Shutler

Follow this and additional works at: <https://scholarworks.umt.edu/tme>



Part of the [Mathematics Commons](#)

Let us know how access to this document benefits you.

---

### Recommended Citation

Shutler, Paul M.E. (2017) "A Symbolical Approach to Negative Numbers," *The Mathematics Enthusiast*.  
Vol. 14 : No. 1 , Article 13.

Available at: <https://scholarworks.umt.edu/tme/vol14/iss1/13>

This Article is brought to you for free and open access by ScholarWorks at University of Montana. It has been accepted for inclusion in The Mathematics Enthusiast by an authorized editor of ScholarWorks at University of Montana. For more information, please contact [scholarworks@mso.umt.edu](mailto:scholarworks@mso.umt.edu).

## **A Symbolical Approach to Negative Numbers**

Paul M.E. Shutler<sup>1</sup>

National Institute of Education, Nanyang Technological University,  
Republic of Singapore

**Abstract:** Recent Early Algebra research indicates that it is better to teach negative numbers symbolically, as uncompleted subtractions or “difference pairs”, an idea due to Hamilton, rather than abstractly as they are currently taught, since all the properties of negative numbers then follow from properties of the subtraction operation with which children are already familiar. Symbolical algebra peaked in the 19th Century, but was superseded by abstract algebra in the 20th Century, because Peacock’s permanence principle, which asserted that solutions obtained symbolically would actually be correct, remained unproven. The main aim of this paper is to provide this missing proof, in order to place difference pairs on a rigorous mathematical foundation, so that they may for the first time be the subject of modern classroom based research. The essential ingredient in this proof is a new physical model, called the banking model, a development of the hills and dales model used in schools in New Zealand, which besides improving upon current models in several respects, has the crucial advantage of being a true physical model, that is, the properties of negative numbers come from freely manipulating the model in the manner of a sandbox, not by following an abstract set of rules. Throughout this paper a close correspondence is drawn between negative numbers viewed as uncompleted subtractions and fractions viewed as uncompleted divisions, which suggests a practical notation for difference pairs as single numbers but whose digits are either positive or negative, the equivalent for integers of the decimal fraction notation for rationals. The banking model is the ideal tool for visualising such positive and negative digits, and examples are provided to show not only that this is a powerful notation for use at Secondary level, but also that it resolves some long-standing problems of the subtraction algorithm at Primary level.

**Keywords:** negative numbers, integers, fractions, rational numbers,  
symbolical algebra, Early Algebra, Chinese mathematics.

**AMS Subject Classification:** 97A30, 97D20, 97F40, 01A25.

### **Introduction**

#### **Status Quo**

It is a well known fact from the History of Mathematics that negative numbers were not widely accepted by mainstream European mathematicians until the Eighteenth Century, and then only after much controversy (Katz, 2009). By contrast, the arithmetic of rational numbers was known in essentially its modern form to Diophantus in the Third Century (Heath, 1910; Klein,

---

<sup>1</sup> paul.shutler@nie.edu.sg

1968) and the Ancient Egyptians possessed a system of unit fractions more than two thousand years earlier (Chace, 1979). It is therefore unsurprising that negative numbers are regarded as difficult to teach (Hitchcock, 1997; Hefendehl-Hebeker, 1991) or, as the *Report of the Cambridge Conference on School Mathematics* put it, “Perhaps no area of discussion brought out more viewpoints than the question of how the multiplication of signed numbers should be introduced” (Cambridge, 1963). Comparatively, the properties of rational numbers are greeted with far less trepidation, especially when armed with a suitable physical model. This difference in difficulty is also seen in the order of contemporary school curricula, with negative numbers, regarded as more abstract, generally delayed until secondary school, while fractions, viewed as more concrete, can be taught as early as lower primary.

While this may represent the status quo which has existed for many years, mathematics educators are naturally resistant to the idea that certain topics are difficult to teach, or can only be taught to the more able student. Indeed, each new generation of researchers seems to yield a fresh initiative for overcoming the barriers to entry into higher mathematics, such as the New Math in the 60’s and 70’s (Cambridge, 1963; Southampton, 1961) or the Reform Mathematics in the 80’s and 90’s (Cockcroft, 1982; Standards, 1989). Most recently, the 2000’s and 2010’s have seen the development of the Early Algebra movement, which aims to smooth out the abrupt jump from primary school arithmetic to secondary school algebra by selectively introducing certain kinds of algebraic thinking into primary schools (Carragher & Schliemann, 2007). Unlike the New Math and Reform Mathematics movements, both of which achieved mixed success, a key research finding already obtained by Early Algebra research is that young children are capable of a much higher level of abstract thought than previously believed (Mason, 2008). In particular, even children of lower primary school age have been found to be able to work with negative numbers, well before the point at which this topic is normally introduced (Bishop *et al.*, 2011; Wilcox, 2008; Behrend, 2006).

Concern over negative numbers is not confined to the Early Algebra movement, however, and the many research articles recently published on this topic show that important issues still remain unresolved (e.g. Almeida & Bruno, 2014; Bishop *et al.*, 2014; Bofferding, 2014; Leong *et al.*, 2014; Whitacre *et al.*, 2012; Selter *et al.*, 2012; Altıparmak & Özdoğan, 2010). All these articles feature classroom based research, where the mathematical content can be assumed fixed, and different teaching approaches are investigated. This article also aims to improve classroom teaching, but the exactly opposite way: it considers different approaches to the mathematics, and existing classroom based research is used to justify that what is proposed is worth trying with children. In other words, rather than searching for a pedagogy which matches the difficulty level of the mathematics, the difficulty level of the mathematics is lowered to match the available pedagogy. That changes to the mathematics should be possible at all is justified in the next section, which highlights unresolved mathematical issues in each of the three strands mentioned in the first paragraph, namely: the historical origins of negative numbers, their mathematical definition, and the physical models used in teaching.

### **Three Strands**

First, it is insufficiently widely appreciated that the History of Mathematics is a developing subject, with discoveries still being made, especially through new or improved translations (Robson, 2002; Netz & Noel, 2007). In particular, the historical development of mathematics is non-linear, and essentially the same concepts can arise at different times and places and in

different ways. A good example illustrating both of these points is *The Nine Chapters on the Mathematical Art* which, despite occupying the same pivotal role in Classical Chinese mathematics as Euclid's *Elements* did in Ancient Greece, has been available in full English translation only since 1999 (Shen, *et al.*). This contains a well developed system of negative numbers, but apparently without the controversies which dogged the acceptance of negative numbers by European mathematicians two thousand years later (Martzloff, 1997, p. 200). That negative numbers should have developed in China so much earlier and more easily than in Europe is surely of relevance to the debate surrounding the teaching of negative numbers today. Nevertheless, most of the articles which consider integers from an historical perspective focus on the canonical Hindu–Arabic–European succession (Hitchcock, 1997; Hefendehl-Hebeker, 1991; Katz, 2009) while Ancient Greek or Classical Chinese mathematics receive only an occasional mention (Bishop *et al.*, 2014; Gallardo, 2002; Sesiano, 1985).

Second, there are good reasons why integers could be taught *before* rational numbers, not after, (Freudenthal 1973, p. 280; Rowland, 1982, p. 26). Integers arise from allowing unrestricted subtraction, while rational numbers arise from allowing unrestricted division, and certainly subtraction comes before division, both logically and in terms of difficulty. More precisely, both the integers and positive rational numbers are *semigroup extensions* of the natural numbers (Bruno & Martínón, 1999; Hollings, 2014), constructed as ordered pairs under an equivalence relation, so that additive and multiplicative inverses exist. Viewed this way, there is an exact correspondence between integers and rationals under a transformation which replaces every addition with a multiplication and every subtraction with a division. Exactly this semigroup approach was adopted by many textbooks of the 60's and 70's (Keedy, 1969; Griffiths & Hilton, 1970; Campbell, 1970; Hunter *et al.*, 1971; Mendelson, 1973), which treated arithmetic rigorously, mainly for the benefit of school teachers, but the only systematic attempt to teach children this way, Nuffield Mathematics (1969), did not last. Why it failed is, again, surely of contemporary interest and yet, save for a note on Wikipedia (Wikipedia), the ordered pairs approach to negative numbers seems to have been forgotten.

Third, one reason why fractions are in practice easier to teach is the existence of a good physical model, namely, the cutting up of a quantity of matter, Avogadro's constant being so large that, for all practical purposes, any amount of matter is arbitrarily divisible. By contrast, the traditional number line model of integers, despite being the mainstay of classroom teaching for many years, has more recently been regarded by researchers as facing serious issues and to be in need of replacing (Freudenthal, 1973; Freudenthal, 1983; Rowland, 1982; Küchemann, 1981; Fischbein, 1987). In fact, in a debate reminiscent of the Ancient Greek debate over the indivisibility of the unit (Klein, 1968), it has even been argued that a physical model of negative numbers is an impossibility (Fischbein, 1987, p. 100), after all, how can you have less than nothing? Since integer arithmetic appears to require formal operations, in the sense of Piaget, lack of a suitable model would then confine negative numbers to secondary school (Galbraith, 1974). Although several alternative physical models have been suggested over the years, such as those based on electric charges or notions of credit and debt, these too have issues, and a suitable replacement for the number line is still lacking.

### **Contribution of this Article**

The three main parts of this article each focus on one of these three strands, starting with Part A which is a historical literature survey. A parallel is drawn between the use of negative

numbers in *The Nine Chapters* for solving linear equations and Cardano's use of imaginary numbers in the context of solving cubic polynomials, showing that these extended number systems were more easily accepted because they gave correct solutions to problems apparently not involving negative or imaginary numbers at all. At first the algebra was symbolical, but the failure to turn Peacock's permanence principle into a proven theorem led to a shift towards a more abstract approach based on ordered pairs under an equivalence relation. The high levels of abstraction involved were the most likely cause for the failure of this approach in the 60's and 70's. Early Algebra research indicates, however, that a symbolical approach to teaching is more likely to succeed where past abstract approaches failed.

Part B presents Peacock's (1845) symbolical approach to negative numbers. By analogy with rationals constructed as uncompleted divisions  $a/b = a \div b$ , integers are constructed as uncompleted subtractions or *difference pairs*  $a - b$ , where  $a$  and  $b$  are natural numbers, an idea originally due to Hamilton (1837). All the properties of negative numbers then follow simply from properties which the subtraction operation already possesses over the set of natural numbers. Indeed, the many different cases which normally have to be considered separately in integer arithmetic, according to the sign and relative magnitude of the numbers involved, always condense down to a single case. Moreover, a crucial advantage which difference pairs enjoy over the failed ordered pairs approach of the 60's and 70's emerges, that subtraction of difference pairs is defined not using the abstract concept of additive inverses, but concretely using a property of the subtraction operation with which most children are already familiar.

Part C introduces the *banking model*, which represents integers not as absolute amounts of money but as account balances supported by an indefinitely large amount of bank money. A mathematical proof is provided showing that it is a true physical model, that is, the properties of negative numbers arise solely by manipulating the model according to the laws of physics, not by following a set of abstract rules. Applying this proof to solve the key problem from *The Nine Chapters*, a means of proving the permanence principle in general becomes apparent, by constructing extended number systems as subsets of the natural numbers, not the other way around. In particular, the essential property which makes negative numbers useful is that they express how uncompleted subtractions effectively behave if, in a problem solving context, they are rendered completeable by including a sufficiently large additive constant.

A symbolical approach to negative numbers is therefore mathematically just as rigorous as the current abstract approach, and should work better in practice. So there is no obstacle to the use of difference pairs in the classroom where, for the first time, they can be the subject of modern education research methods. Such studies are beyond the scope of this article, but it concludes by looking at how difference pairs might be written in practice. The exact correspondence between integers, viewed as difference pairs, and rational numbers suggests a practical notation for difference pairs as single numbers but whose individual digits can be positive or negative, which is the equivalent for integers of the decimal fraction notation for rationals. Examples are provided to show how this notation could improve the subtraction algorithm taught in primary school, and the capability of the banking model to carry several registers in parallel makes it the ideal tool for visualising such computations. This notation can help represent and also evaluate power series, including those used to compute logarithms and for constructing spigot algorithms for  $\pi$ . Finally, some overall conclusions are drawn regarding the introduction of extended number systems and physical models in schools.

## Part A: Literature Review

### Historical Origins of Negative Numbers

*The Nine Chapters on the Mathematical Art*, a collection of solved problems dating from the Tenth to Second Centuries BC, is “the supreme Classical Chinese mathematical work” (Shen *et al.*, 1999). Chapter 8 is devoted to the solution of systems of linear equations by a procedure essentially identical to modern Gaussian elimination. For two equations in two unknowns with positive coefficients, it is always possible to permute the order of variables and equations so that Gaussian elimination never encounters negative numbers. For three equations in three unknowns, however, negative numbers can be unavoidable, even when both problem and solution can be expressed entirely in terms of positive numbers, an example of which taken from *The Nine Chapters* is shown in Figure 1. While it is possible to solve such cases without recourse to negatives, by carefully adding multiples of rows to other rows, the result is a more complicated algorithm. Instead, *The Nine Chapters* retained the simplicity of Gaussian elimination, accepting the need to work temporarily with negative coefficients, and formulated rules for manipulating negative numbers essentially identical to our own.

This stepping outside an accepted set of numbers in order to preserve the simplicity of an algorithm has a striking parallel with the case of Cardano’s solution of the cubic polynomial published in his *Ars Magna* in 1545 (Katz, 2009). After a linear shift to remove the quadratic term, Cardano showed the solution of the cubic polynomial in the resulting standard form  $x^3 = 3mx + 2n$  was  $x = \sqrt[3]{n + \sqrt{n^2 - m^3}} + \sqrt[3]{n - \sqrt{n^2 - m^3}}$ . In the case  $n^2 > m^3$ , when the cubic is called *reducible*, there is only one real solution, and Cardano’s formula gives it correctly. When  $n^2 < m^3$ , however, when the cubic is called *irreducible*, this formula involves apparently nonsensical square roots of negative numbers even though, surprisingly, the three solutions are in this case all real. While Viète showed that it was possible to avoid using “imaginary” numbers such as  $\sqrt{-1}$ , by employing trigonometric identities instead, this results in a quite different formula (Katz, 2009, p. 413). Instead, first Cardano himself then, building on his work, Bombelli and later mathematicians, showed that by working with such imaginary expressions it was possible to obtain all three real solutions correctly (Katz, 2009).

By the Nineteenth Century, the weight of results obtained using negative and imaginary numbers had convinced most mathematicians of their indispensability. Nevertheless, several influential figures pointed out that until these extended number systems had been placed on rigorous foundations, results obtained using them might be incorrect (Hitchcock, 1997, p. 18; Pycior, 1981, p. 27). This impasse was broken by George Peacock, who distinguished between *arithmetical algebra* (Peacock, 1842) where all expressions could be evaluated, and *symbolical algebra* (Peacock, 1845) where expressions could be uncompleteable. Arithmetical expressions were equal when they evaluated to the same number, but symbolical expressions were equal when one could be transformed into the other using the properties of the operations involved (Peacock, 1845, Art. 632). In his famous *principle of the permanence of equivalent forms*, Peacock argued (1845, Ch. 15) that working with negative and imaginary numbers did make sense provided they were manipulated using properties which the subtraction and square root operations already possessed over the positive real numbers. By respecting these properties one could be sure that solutions obtained symbolically, but which turned out to be real and positive, would necessarily be correct, that is, satisfy the original problem (1845, Art. 974).

$$\begin{aligned}
 R_1 &: 2x + y + 0 = 1 \\
 R_2 &: 0 + 3y + z = 1 \\
 R_3 &: x + 0 + 4z = 1
 \end{aligned}$$

$$R_3 \rightarrow 2R_3 - R_1$$

$$\begin{aligned}
 R_1 &: 2x + y + 0 = 1 \\
 R_2 &: 0 + 3y + z = 1 \\
 R_3 &: 0 + -y + 8z = 1
 \end{aligned}$$

$$R_3 \rightarrow 3R_3 + R_2$$

$$\begin{aligned}
 R_1 &: 2x + y + 0 = 1 \\
 R_2 &: 0 + 3y + z = 1 \\
 R_3 &: 0 + 0 + 25z = 4
 \end{aligned}$$

$$z = \frac{4}{25} \quad y = \frac{7}{25} \quad x = \frac{9}{25}$$

*Figure 1.* Problem 3 from Chapter 8 of *The Nine Chapters* and its solution via Gaussian elimination as given in that text, where the presence of so many zeros in the initial problem statement makes the use of negative numbers unavoidable.

### Mathematical Definitions

By the mid-Nineteenth Century Peacock's permanence principle had been widely accepted, but the lack of formal proof left some doubt whether symbolical algebra constituted a *rigorous definition* of negative and imaginary numbers (Pycior, 1982; Phillips). This difficulty was solved by Hamilton who, despite being an early critic of symbolical algebra, defined complex numbers in terms of ordered pairs (Katz, 2009; Hamilton, 1837). Although the operations defined on these

pairs were chosen to match the properties obtained from symbolical algebra, Hamilton stressed the difference between the two approaches: “In the THEORY OF SINGLE NUMBERS, the symbol  $\sqrt{-1}$  is *absurd*, and denotes an IMPOSSIBLE EXTRACTION, or merely IMAGINARY NUMBER; but in the THEORY OF COUPLES, the same symbol  $\sqrt{-1}$  is *significant*, and denotes a POSSIBLE EXTRACTION, or a REAL COUPLE, namely the *principal square-root of the couple*  $(-1,0)$ ” (Hamilton, 1837, *Couples*, Art. 13, original emphasis). Later Steinitz adopted the same approach to construct the field of fractions of an integral domain, except that the set of pairs in this case required also to be divided by an equivalence relation (Hollings, 2014, Sec. 2.1). It was then realised that the same formalism, which obviously applied to rational numbers, applied to integers as well, and this is the form which entered the textbooks (Keedy, 1969; Griffiths & Hilton, 1970; Campbell, 1970; Hunter *et al.*, 1971; Mendelson, 1973).

As Freudenthal notes, “the didactical value of [equivalence classes] is rather problematic” and “even the most severe mathematicians” do not really think in these terms (1973, p. 226). It is therefore unsurprising that the only systematic attempt to teach negative numbers as ordered pairs, the Nuffield Mathematics of the 60’s and 70’s (Nuffield, 1969), did not succeed. Despite anecdotal evidence that the sections devoted to negative numbers were in fact the most problematic (Galbraith, 1974; Rappaport, 1971), there is no actual research evidence dating from this period showing *why* the approach failed, only the unique study by Rowland from 1982 giving any insight into this question (Rowland, 1982). So although it seems clear that the very high levels of abstraction involved in teaching integers as equivalence classes of ordered pairs was to blame, one cannot be sure. Since ordered pairs evolved historically from symbolical algebra, however, this suggests teaching integers instead as symbolical expressions of the form  $a - b$ , which the equivalence classes supposedly represent. Recent Early Algebra research suggests that such an approach might well succeed.

Early Algebra does *not* mean pulling secondary school algebra down into primary school, but instead means attempting to bridge the gap between the two (Mason, 2008; Carraher *et al.*, 2008). To understand to what extent young children are capable of algebraic thought, the first step is to formulate a working definition of algebra, which is usually done in terms of generalisations (Jacobs *et al.*, 2007; Bastable & Schifter, 2008) in particular of two kinds (Carraher & Schlieman, 2007). First is the generalisation of *number*, such as a sequence of arithmetic equalities varying in a regular pattern,  $1 + 3 = 2^2$ ,  $1 + 3 + 5 = 3^2$ ,  $1 + 3 + 5 + 7 = 4^2$  (Kaput, 2008; Carraher *et al.*, 2006). Research has shown that primary school children are able to observe and verbally articulate such patterns, although writing algebraic expressions involving variables,  $1 + 3 + \dots + (2n - 1) = n^2$ , they find much more difficult (Bastable & Schifter, 2008). Second there is generalisation of *operation* (Jacobs *et al.*, 2007; Franke *et al.*, 2008), such as manipulating an arithmetic expression without changing its value,  $(45 - 7) + 17 = 45 + (17 - 7)$ , especially when, as in this example, the computational effort required is reduced as a result. This second kind of generalisation is known as *relational thinking* (Jacobs *et al.*, 2007; Franke *et al.*, 2008), essentially an application of Skemp’s *relational understanding* (Skemp, 1976) to arithmetic operations. That children possess this kind of relational understanding of operation, especially for differences  $a - b$  (Schifter *et al.*, 2008), supports the claim made in Part B that integers can be taught as difference pairs.

### Physical Models Used in Teaching

Introduced by Wallis in 1685 (Heeffer, 2011), the *number line* has become so ubiquitous



that it is hard to believe it is failing in its original purpose (Küchemann, 1981, p. 87). Yet studies have shown that children perform better on stand alone integer arithmetic than on number line tasks (Carr & Katters, 1984; Ernest, 1985), the opposite of what should happen if the number line were helping. This is because the number line is not a model in the strict sense (Heeffer, 2011), instead is “built... to fit step by step, through a system of artificial conventions, the rule of signs” (Fischbein, 1987, p. 100), also (Freudenthal, 1983, p. 437), or, more simply, “[it] does not have any compelling inner logic” (Ernest, 1985). Even the order of the integers on the number line, which is pedagogically crucial, is not self-evident, and children spontaneously produce the same alternative layouts (Temperley, 1912) that were debated historically (Hefendehl-Hebeker, 1991, p. 27; Thomaidis & Tzanakis, 2007). One weakness is that positions cannot be added, so each integer must confusingly be represented both as a *position on*, and as a *movement along* the line (Rowland, 1982, p. 24) the addition of positions and movements being asymmetric. One can dispense with positions and just add movements, but the lack of absolute location in the resulting *vector model* makes it dissimilar to the number line, and creates other pedagogic problems (Galbraith, 1974; Ulrich, 2012).

An alternative which became popular in the 60’s (Ashlock, 1967) and which outperforms the number line (Liebeck, 1990; Kaner, 1964) is the *electric charges model*, where integers are represented by electric charges, colour coded according to the sign, with the rule that positive and negative charges cancel. Freudenthal (1983, p. 439) credits Gattegno, but since coloured rods were already used in Classical China to represent signed numbers (Shen *et al.*, 1999; Martzloff, 1997), scientists most likely adopted the same convention when electric charges were found to behave the same way. One advantage of the charges model is that addition is symmetrical: one merely brings sets of charges together and allows whatever cancellation may happen. The cancellation of opposite charges is not, however, self-evident to children, who have little physics intuition at that age, so the model risks becoming merely an abstract representation. A major disadvantage is that, unlike the number line, which naturally allows counting below zero, arbitrary subtraction is not immediately possible as one cannot always see the charges one is trying to subtract (Rowland, 1982, p. 25). Sufficiently many positive and negative charges must first be created in pairs (Rowland, 1982; Ashlock & West, 1967; Kaner, 1964) and although physicists assure us that pair creation is true in nature, this is clearly even less part of children’s intuition than charge cancellation.

Models based on credit and debt encounter similar problems to electric charges, in that concepts familiar to adults may not necessarily be so to children (Peled & Carraher, 2008). Monetary models also suffer problems of visualisation in that, negative amounts of money not physically existing, children tend to think of debt not as a negative amount associated with one person, but as a positive amount associated with someone else (Peled & Carraher, 2008). Another model, which has the significant advantage over other models that the cancellation of positive and negative is intuitively clear as the filling in of a hole (Sawyer, 1964; Gibbs, 1977) is commonly taught in New Zealand schools as the *hills and dales* or *bumps and holes* model (New Zealand, 2014; Hughes, 2012). Its written form can, however, be unwieldy, since hills and dales cannot be stacked but must be laid out horizontally, and short cuts which make the drawing less tedious also make it less intuitive and more abstract. Each of these models do, however, illustrate separately four features we would ideally like to see: arbitrary subtraction, symmetrical addition, intuitive cancellation, and compact representation. Part C presents the banking model, essentially a development of hills and dales, which possesses all four.

## Part B: The Symbolical Definition of Integers

### Ordered Pairs *versus* Difference Pairs

Some insight into why an ordered pairs approach to integers failed in the 60's and 70's can be gained, despite the lack of evidence, by looking at corresponding evidence which does exist for fractions. Two studies close in time to Nuffield were the CSMS study 1974-79 (Hart, 1981) and the SEMS study 1980-84 (Kerslake, 1986) which showed that over emphasis on the parts whole definition meant children tended to think of a fraction as a pair of numbers, rather than as a number in its own right. This resulted in a range of conceptual errors, involving fraction equivalence and arithmetic operations, where children operated on numerators and denominators separately in ways inconsistent with their definition. The solution to this problem recommended at the time was to emphasise instead the concept of fractions as quotients  $a \div b$ , that is, symbolically as uncompleted divisions (Kerslake, 1986; Domoney, 2002), and evidence existed that such an approach might succeed. In particular, equivalence of fractions can then be interpreted as doing any part of the division which does make sense, for example,  $6 \div 8 = (6 \div 2) \div 4 = 3 \div 4$ . Recent Early Algebra research shows that primary school children can overcome the problems highlighted by these studies through working with fractions as uncompleted divisions (Empson *et al.*, 2011; Empson & Levi, 2011).

The corresponding approach for integers would define them symbolically as uncompleted subtractions or *difference pairs* of natural numbers  $a - b$ , an idea originally due to Hamilton (1837, *Pure Time Art.* 2). Equivalence of difference pairs would mean doing any part of the subtraction which makes sense (Rowland, 1982, p. 24), for example,  $8 - 5 = (8 - 2) - 3 = 6 - 3$ , and Early Algebra research shows this concept is within the ability of primary school children (Russell *et al.*, 2009; Russell *et al.*, 2011a; Russell *et al.*, 2011b). One can always cancel the smaller of  $a$  and  $b$  against part of the larger to give something wholly positive or negative, and hence recover the usual definition of integers as signed numbers,  $n - 0 = +n$  or  $0 - n = -n$  (Rowland, 1982, p. 25). It is well known, however, that children find confusing the three different senses in which the minus sign is traditionally used, namely as subtraction, negative and negation (Lamb *et al.*, 2012a, Lamb *et al.*, 2012b, Bofferding, 2010; Vlassis, 2008). Writing integers as difference *pairs* therefore has the benefit that the minus sign only ever means subtraction. In fact, following Peacock, if the notation is abbreviated by deleting the unnecessary zeros, that is, writing  $n$  for  $n - 0$  and  $-n$  for  $0 - n$ , then we recover the notation which *de facto* is used everywhere outside of lower secondary school classrooms.

Viewing integers symbolically as uncompleted subtractions is essential for understanding the ordered pairs approach used in textbooks of the 60's and 70's (Keedy, 1969; Griffiths & Hilton, 1970; Campbell, 1970; Hunter *et al.*, 1971; Mendelson, 1973). This is because ordered pairs were used as a means to rewrite symbolical statements in ways which avoided subtractions, so the resulting additive statements are then very difficult to understand unless compared with the symbolical original. For example, the symbolical equality of difference pairs  $a - b = c - d$  became the equivalence relation  $(a, b) \sim (c, d)$  when  $a + d = b + c$ , but even simple things, such as why every ordered pair is equivalent to either an  $(n, 0)$  or a  $(0, n)$ , are then hard to see. In the Nuffield approach, equivalence of ordered pairs was taught using this flipped addition (Nuffield, 1969), and although motivated in ingenious mechanical and diagrammatic ways, this was clearly something which children found difficult. Similarly, the way arithmetic operations were defined in the ordered pairs approach, and the point at which these two approaches differ,

cannot easily be understood without first seeing the symbolical original. Since Peacock's own derivation (Peacock, 1842; Peacock, 1845) was written in a style not easily accessible to a modern audience, and was spread over three dozen pages split between two volumes, the following summary is provided for the convenience of the reader.

### Integer Operations on Difference Pairs

First, when adding two expressions involving both additions and subtractions, all terms with the same sign can be added together provided the subtractions are completeable (Peacock, 1842, Art. 20), for example,  $(10 - 7) + (6 - 3) = (10 + 6) - (7 + 3)$  since  $3 + 3 = 16 - 10$ . Applying the permanence principle means asserting that this equality is still true even when the subtractions are not completeable (Peacock, 1845, Art. 548), so all the numbers can therefore be replaced by variables to yield the following *addition of difference pairs* formula:

$$(a - b) + (c - d) = (a + c) - (b + d). \quad (1)$$

Since one cannot immediately tell whether the pair  $a - b$  corresponds to a positive or to a negative integer, this definition of addition should handle in one step what are normally considered to be several different cases. For example, an (absolutely) larger positive added to a smaller negative  $+7 + -4 = +3$ , becomes  $(7 - 0) + (0 - 4) = 7 - 4 = 3 - 0$ , while a smaller positive added to a larger negative  $+5 + -9 = -4$ , becomes  $(5 - 0) + (0 - 9) = 5 - 9 = 0 - 4$ . The other two cases, two positives or two negatives added together, are also given correctly.

Second, when taking the difference of two expressions, the expression being subtracted can be added with the signs reversed, provided the subtractions are completeable (Peacock, 1842, Art. 23), for example,  $(10 - 7) - (6 - 4) = (10 + 4) - (7 + 6)$  since  $3 - 2 = 14 - 13$ . Applying the permanence principle means asserting that this equality is still true even when the subtractions are not completeable (Peacock, 1845, Art. 549), so all the numbers can therefore be replaced by variables to yield the *subtraction of difference pairs* formula:

$$(a - b) - (c - d) = (a + d) - (b + c). \quad (2)$$

Again, because the sign of  $a - b$  is not immediately obvious, this definition of subtraction should handle in one step what are normally considered to be several different cases. For example,  $+6 - -3 = +9$  is just  $(6 - 0) - (0 - 3) = (6 + 3) - 0 = 9 - 0$ , whereas  $-8 - -5 = -3$  is just  $(0 - 8) - (0 - 5) = 5 - 8 = 0 - 3$ , and similarly for the other cases. That subtracting a negative means adding a positive therefore follows from the property  $x - (c - d) = (x + d) - c$  which the subtraction operation already possesses over the natural numbers. Early Algebra research has shown that primary school children are able spontaneously to understand and articulate this property (Russell *et al.*, 2009; Russell *et al.*, 2011a; Russell *et al.*, 2011b), for example, as the computational shortcut  $x - 98 = x - (100 - 2) = (x + 2) - 100$ . Similarly, dividing by a fraction means multiplying by its reciprocal follows from the property  $x \div (c \div d) = (x \times d) \div c$  which the division operation already possesses, for example, as the shortcut  $x \div 5 = (x \times 2) \div 10$ .

If we define integers as difference pairs, to multiply integers requires the distributive law of multiplication over subtraction  $(a - b) \times (c - d) = ac - bc - ad + bd$  (Peacock, 1842, Art. 56). This formula can be justified using the area analogy shown in Figure 2, or by numerical examples such as  $(10 - 2) \times (10 - 2) = 100 - 20 - 20 + 4$ , since only this way of allocating

signs to the different terms yields the correct answer  $8 \times 8 = 64$ , and both the area analogy and this numerical example were used by Cardano himself (Heeffer, 2011). Applying the permanence principle (Peacock, 1845, Art. 569), the *multiplication of difference pairs* is:

$$(a - b) \times (c - d) = (ac + bd) - (bc + ad). \quad (3)$$

Again, this should neatly encapsulate in one formula what are traditionally regarded as several different cases. For example, a positive times a negative giving a negative,  $+3 \times -2 = -6$  is just  $(3 - 0) \times (0 - 2) = 0 - (3 \times 2) = 0 - 6$ , while a negative times a negative giving a positive,  $-2 \times -3 = +6$  is just  $(0 - 2) \times (0 - 3) = (2 \times 3) - 0 = 6 - 0$ .

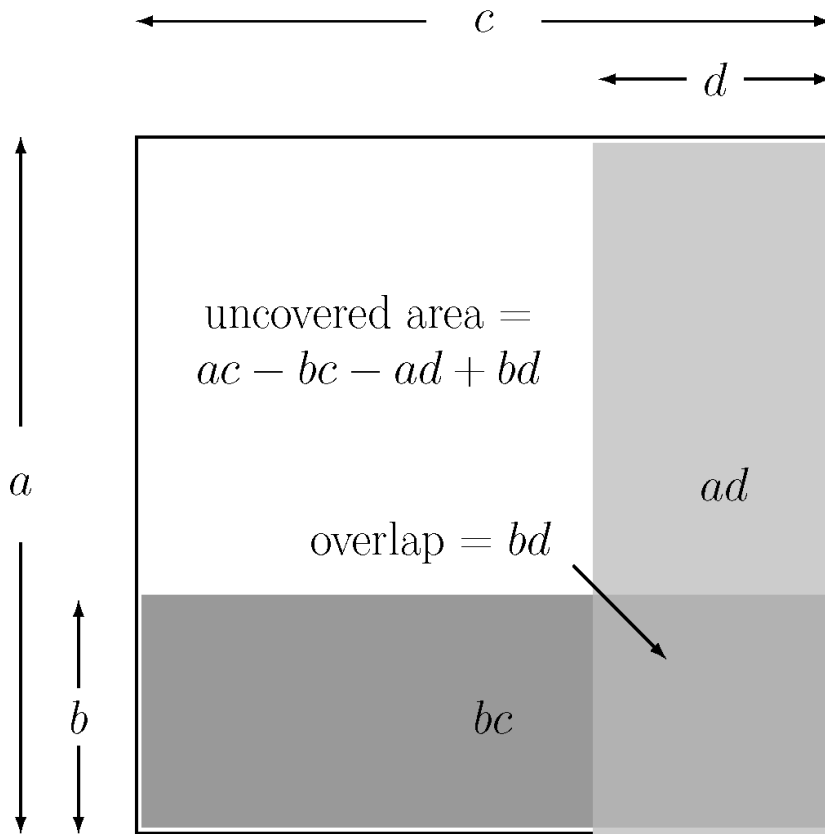

Figure 2. Area based derivation of the distributive law of multiplication over subtraction following the approach of Cardano (Heeffer, 2011), where subtracting the area of the shaded rectangles  $ad$  and  $bc$  from the area of the white square  $ac$ , double subtracts the square of overlap  $db$ , which must therefore be added to compensate.

### Advantages of the Difference Pairs Approach

The advantages of difference pairs over ordered pairs can be seen most clearly for subtraction, upon which the success of any approach to integers must be judged (Rowland, 1982,

p. 26) and which children in the SEMS study found the most difficult operation (Küchemann, 1981). Addition and multiplication of ordered pairs (e.g. Keedy, 1969) are simply Equations 1 and 3 rewritten as  $(a, b) + (c, d) = (a + c, b + d)$  and  $(a, b) \times (c, d) = (ac + bd, bc + ad)$ . Ordered pair subtraction is defined quite differently: since  $(a, b) + (b, a) = (a + b, a + b)$  is in the same equivalence class as  $(0, 0)$ , the class of  $(b, a)$  is the additive inverse of the class of  $(a, b)$ , hence  $(a, b) - (c, d) := (a, b) + (d, c)$ , but for children use of the unfamiliar notion of additive inverses here is highlighted by Rowland (1982, p. 26) as “rather subtle, and discontinuous initially.” For difference pairs, subtraction is defined quite symmetrically with addition, building on existing student knowledge of subtraction. Subtraction as addition with opposite signs does, however, have an equivalent in difference pairs, obtained by combining Equations 1 and 2:

$$(a - b) - (c - d) = (a - b) + (d - c). \quad (4)$$

To subtract a difference pair therefore means to add the ‘reciprocal’, that is, the pair with the terms reversed analogous to dividing by a fraction being to multiply by the reciprocal.

The distributive law of multiplication over subtraction is often used to justify the rules for multiplying integers, by replacing each subtraction by the addition of a negative. Thus, if  $(a - b) \times (c - d) = (+a + -b) \times (+c + -d)$  then  $ac + bd - bc - ad = +a +c + -b -d + -b +c + +a -d$ , so in particular  $-b -d$  must be positive, while  $-b +c$  and  $+a -d$  are both negative. It is interesting to note that Cardano, who was himself unsure of the existence of negative numbers, rejected the validity of this argument (Heeffer, 2011). For Cardano, the distributive law was just a means for computing areas correctly, in particular, the area  $bd$  must be added in this case because in the  $bc$  and  $ad$  terms it has already been double subtracted. Similarly Diophantus, who did not accept negative solutions, regarded the rules of signs primarily as the way to handle terms in equations correctly (Heath, 1910). To define integers as difference pairs is therefore to agree with both Cardano and Diophantus: the distributive law of multiplication over subtraction is just a property of the operations, and it is not the individual terms which are positive or negative, but rather the symbolical *expressions*  $a - b$  and  $c - d$  themselves.

Since fractions consist of *pairs* of elements from the set of natural numbers  $\mathbb{N}$ , the set of all rational numbers  $\mathbb{Q}$  is an apparently much larger set than the set of integers  $\mathbb{Z}$ , so the natural correspondence seems to be between  $\mathbb{Z}$  and the set of *Egyptian numbers*  $\mathbb{E}$ , that is, the whole numbers and unit fractions, as shown in Table 1 (Hefendehl-Hebeker, 1991). Using difference pairs, however, we can demonstrate that there is an exact correspondence between rationals and integers, as mentioned in Section 1.2, not as sets but in terms of the properties of their arithmetic operations. This correspondence is summarised in Table 2, where replacing each  $+$  (respectively  $-$ ) by a  $\times$  (respectively  $\div$ ) converts a formula involving difference pairs into the corresponding formula for rationals. This correspondence does not at first sight appear to extend to the last line of the table, that is, to the multiplication of integers and the addition of fractions, and in the past there has been no reason to consider this case at all. In fact, this is now possible in terms of difference pairs, although imperfectly because multiplication being defined as repeated addition is an inherently more sophisticated operation. Specifically, as explained in Figure 3, a positive times a negative being negative corresponds to the addition of fractions with like denominators, while a negative times a negative being positive (almost) corresponds to the addition of fractions with unlike denominators.

Table 1. Correspondence between the elements of the set of integers (regarded as signed numbers) under addition and subtraction, and the set of Egyptian numbers (natural numbers and their reciprocals) under multiplication and division.

set of integers $Z = \{\dots, \bar{3}, \bar{2}, \bar{1}, 0, +1, +2, +3, \dots\}$	set of Egyptian numbers $E = \{\dots, \frac{1}{4}, \frac{1}{3}, \frac{1}{2}, 1, 2, 3, 4, \dots\}$
$+n + \bar{n} = 0$	$n \times \frac{1}{n} = 1$
$\bar{n} + \bar{m} = \bar{\{n + m\}}$	$\frac{1}{n} \times \frac{1}{m} = \frac{1}{n \times m}$
$x + \bar{n} = x - +n$	$x \times \frac{1}{n} = x \div n$
$x - \bar{n} = x + +n$	$x \div \frac{1}{n} = x \times n$

Table 2. Correspondence between the properties of the set of integers (regarded as difference pairs) under addition, subtraction, and multiplication, and the set of rational numbers under multiplication, division and addition.

set of integers $Z = \{a - b : a, b \in \mathbf{N}\}$	set of rationals $Q = \{a/b : a, b \in \mathbf{N}, b \neq 0\}$
$(a - b) + (c - d) = (a + c) - (b + d)$	$a/b \times c/d = (a \times c)/(b \times d)$
$(a - b) - (c - d) = (a + d) - (b + c)$	$a/b \div c/d = (a \times d)/(b \times c)$
$x - (c - d) = x + (d - c)$	$x \div c/d = x \times d/c$
$(a - b) \times (c - d) = (ac + bd) - (bc + ad)$	$a/b + c/d = (ad + bc)/(bd)$

(a)

the order of  $\times$  and  $-$  swaps

$$(a - 0) \times (0 - d) = 0 - (a \times d)$$

but the negative  $d$  remains

the order of  $/$  and  $+$  swaps

$$a/d + c/d = (a + c)/d$$

but the  $/d$  remains

(b)

the order of  $\times$  and  $-$  swaps

$$(0 - b) \times (0 - d) = (b \times d) - 0$$

and the negative  $d$  and  $b$  become positive

the order of  $/$  and  $+$  swaps

$$a/b + c/d = (a \times d + b \times c)/bd$$

and the dividing  $b$  and  $d$  become (partly) multiplicative

*Figure 3.* Constructing integers as difference pairs allows a correspondence to be made between the multiplication of integers and the addition of fractions where: (a) positive times negative is negative is analogous to the addition of fractions with like denominators, and (b) negative times negative is positive is analogous to the addition of fractions with unlike denominators.

### Part C: A New Physical Model

#### Definition of the Banking Model

Unlike the models of integers considered in Section 2.3, the traditional model for fractions has no accepted name, so it is worth considering what one might call it. A good physical model for fractions should involve a substance which is soft enough to cut into pieces but which also retains its value afterwards. This explains why popular textbooks choices include bakery items, like pizza or cake, divided between hungry mouths, and not marbles which, being made of hard glass, cannot be cut up into fractions without destroying their usefulness. It is not unreasonable, therefore, to call this model the *baking model*, and indeed some of the earliest recorded examples of the use of fractions, Problems 1–6 of the *Rhind Mathematical Papyrus*, involved dividing numbers of loaves equally between several men (Chace, 1979; Gillings, 1962). Conceptually, the Egyptians were restricted to unit fractions, which in textbooks are traditionally represented hieroglyphically as a numeral surmounted by an oval, meaning a whole divided into a number of equal parts (Chace, 1979). To our modern eyes their concept appears limited, but it had the useful feature pointed out by Gillings (1962) that shares thus obtained were not merely equal, in terms of mass, but also were seen to be equal, that is, shares given out had identical visual appearances which helped avoid disputes.

An analogous physical situation for integers is if, with only \$5 in cash, you want to buy something costing \$8. In the absence of other sources of cash the situation is hopeless, since you cannot spend money which you do not have. If you are paying with a debit card linked to a bank account, however, and that account has a credit facility, then you *can* spend more than you have, by spending some of the bank’s money as well as your own. This situation is pictured in Figure 4, where your \$5 is a *stack* sitting on top of what is effectively an infinite amount of the bank’s money, so spending \$8 will result in a *well* \$3 deep in the bank’s money which represents your debt. This model should therefore be called the *banking model*, and is a development of the hills and dales model (New Zealand, 2014) in that the hills and dales can be stacked and measured as in Bartolini’s model (Bartolini, 1976). It overcomes some of the problems faced by previous attempts to incorporate notions of credit and debt (Peled & Carraher, 2008), because, not knowing exactly how much money the bank has, attention is on the stacks and wells, not the bank money round it, and the institutional impersonality of the bank means the debt must be personal to you and not merely a loan made by a friend.

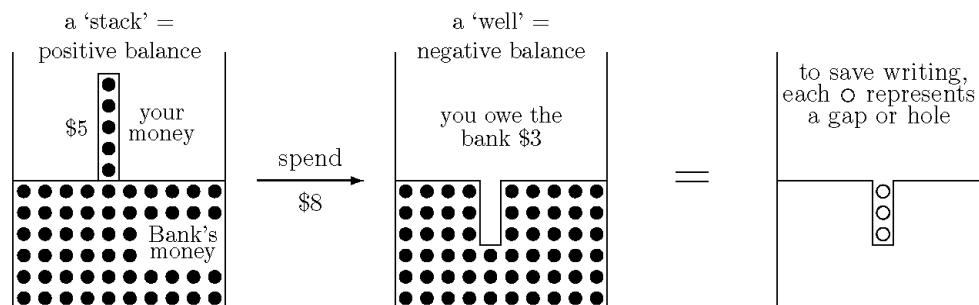
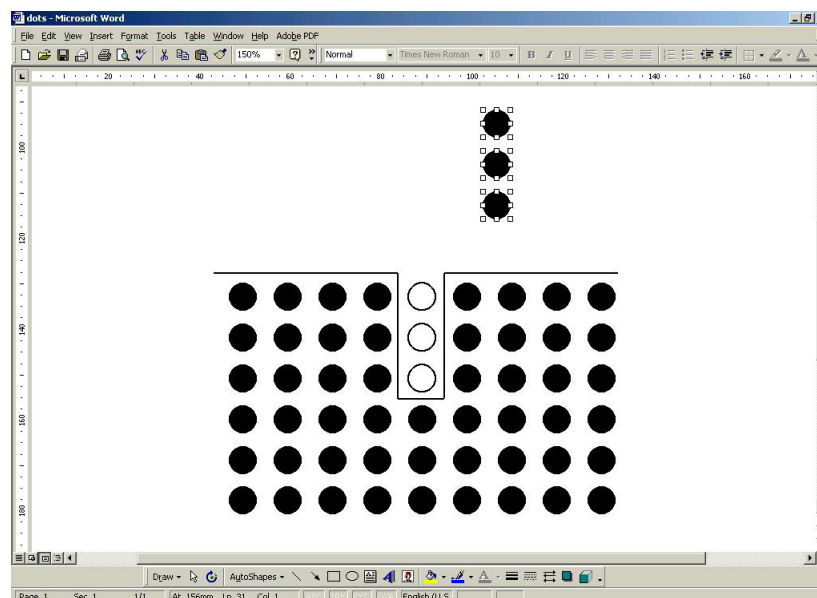

Figure 4. The banking model of positive and negative integers represented as stacks or wells, sitting on top of an indefinitely large amount of bank money.



To maintain this good intuition, bank money should ideally be represented as very many black circles ●, so that debt is clearly perceived as an absence of money. For ease of drawing, however, it is tempting to skip most of the black circles and represent the gaps by white circles ○ as shown in Figure 4, but this risks turning the model into just an abstract representation. To avoid this, a hands on component should be included in teaching, such as a manipulative with counters in a gravity driven frame resembling the “Connect Four” game (Connect Four). Less costly software alternatives exist, and the drawing facilities of many word processors and document viewers, such as Microsoft Word or Foxit Reader, are easily adapted for this purpose, allowing one to copy and paste many identical black circles, as shown in Figure 5. Other advantages of using software include: “snap-to-grid” features which line the circles up automatically in neat rows and columns; being able to select and drag several circles together as a block; dragging in many small steps to create short animations using the undo/redo function; being able to circulate prepared files to every child in a class over a network.



*Figure 5.* Use of “drawing” mode in MS-Word to represent the banking model, showing how to click and drag several black circles together as a block.

### Integer Operations in the Banking Model

As well as making arbitrary subtraction possible, another advantage of the banking model is that addition is symmetrical, two bank accounts being brought together and their balances simply combined. A sandbox analogy is useful here, the two bank accounts being thought of as two sand filled compartments juxtaposed, which are combined by removing the partition separating them. This is illustrated in Figure 6(a) in the case of the addition of two positives, where the two stacks are combined into one, like sweeping together two piles of sand. More interesting are the cases of the addition of a positive and a negative, shown in Figures 6(b)(c), where the well is partially or completely filled by material from the stack, depending upon their relative absolute sizes. The most interesting case is the addition of two negatives shown in Figure

6(d), where one well must be excavated more deeply in order to provide sufficient material to completely fill the other, but at this point the drawback of representing gaps as white circles becomes apparent. The tendency among students in this case is to draw the arrow in the wrong direction, imagining that gaps can be moved, when in fact it is only the actual dollars represented by black circles which can move, and in the opposite direction.

Of the six possible cases of subtraction, the two which involve subtracting an absolutely smaller integer from an integer with the same sign are shown in Figure 7. At first sight these two cases appear to be easy, because we can see within the stack or well what we are trying to take away, so we just reduce the height of the stack or the depth of the well accordingly. Figure 7(a)(b) are strictly speaking wrong, however, since in the banking model we should be adding or subtracting bank *accounts*, not amounts of dollars which are always natural numbers. Correct versions are shown in Figure 7(c)(d), where the stack is divided into two shorter stacks, or the well is divided into two shallower wells, before subtracting, which in our sandbox analogy would mean putting the partition back in, then taking one of the compartments away. In particular, Figure 7(d) shows that any flat part of the sandbox can represent a negative account balance if we first remove a few dollars, so even the subtraction of negative numbers is always a “natural” take away operation, that is, we can “see” what we are trying to take away. The other four cases, subtracting either from something absolutely smaller and the same sign, or from something with a different sign, are shown in Figure 8.

Multiplication by a positive integer poses no problems provided we regard multiplication as repeated addition, which from the above discussion we can already do. The cases of a positive times either a positive or a negative are illustrated in Figure 9(a)(b) where either the stacks are collected together into a single stack, or one deep well is excavated to fill up all the other wells. Multiplication by a negative is more difficult, perhaps impossible (Fischbein, 1987; Leddy, 1977), as our intuition for what this means physically is poor, so the usual solution is algebraic, based on the distributive law. For example, if  $-3 \times +5$  is added to  $+3 \times +5$  gives  $(-3 + +3) \times +5 = 0 \times +5 = 0$  then  $-3 \times +5$  must be the additive inverse of  $+3 \times +5$ , or  $-15$ . Given this, we can then similarly add  $-3 \times -5$  to  $-3 \times +5$  to give zero, hence  $-3 \times -5$  is  $+15$ . While there seems to be no definitive answer to this difficult problem, one way to remain within the physical model is to interpret multiplication by a negative as repeated *subtraction* rather than addition (Cotter, 1969). Figure 9(c)(d) illustrates  $-3 \times +5$ , which means take away three lots of  $+5$ , presumably from zero, which leaves behind three lots of  $-5$  to be added together, and  $-3 \times -5$  means take away three lots of  $-5$ , releasing three lots of  $+5$ .

### Proving the Permanence Principle

The many examples shown in Figures 6 to 9 may give a false impression that the banking model is just a set of abstract rules, but that it is in fact a true physical model can be proven mathematically. This is done by representing bank money as whole numbers of millions of dollars, customer money as small variations about these, then showing that integer operations become natural number operations, which can therefore be physically carried out. Using our earlier example, if the bank has \$3 million and we deposit \$5, then the bank will have \$3,000,005 which therefore represents the integer  $+5$ , then if we buy the T-shirt costing \$8 the bank will have  $\$3,000,005 - \$8 = \$2,999,997$  which represents  $-3$ . The abstract rules for the

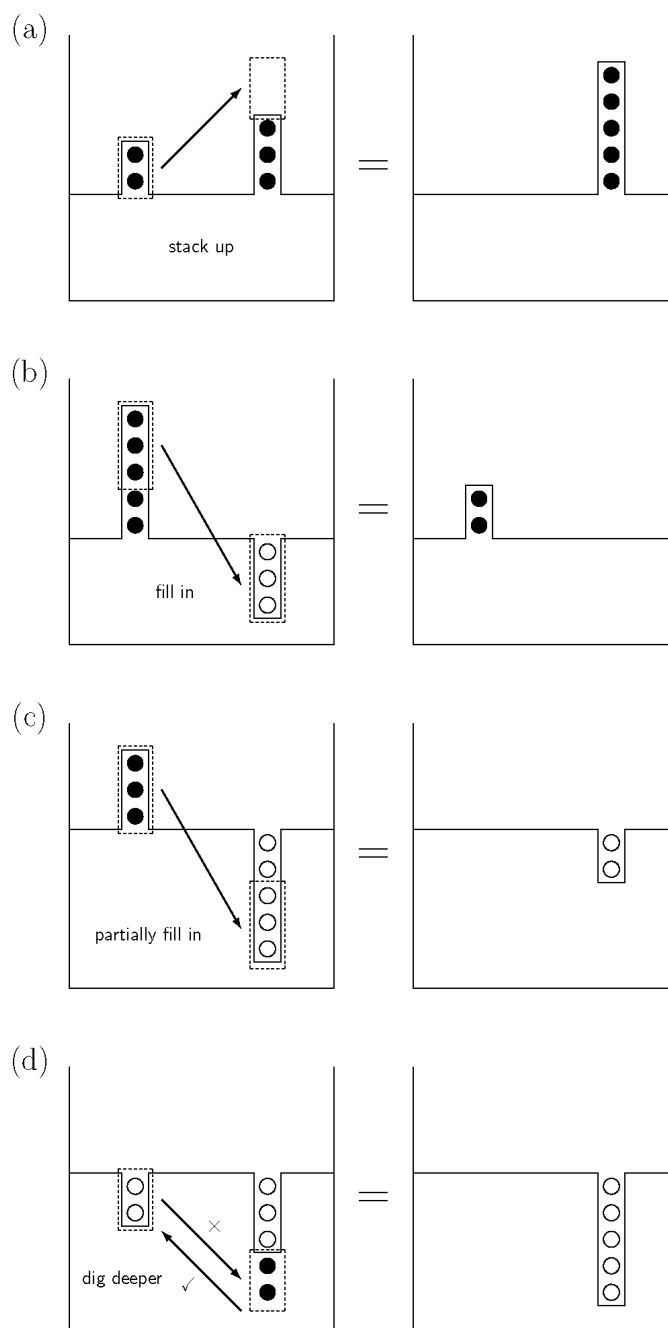

*Figure 6.* The four different cases of addition of integers computed using the banking model, illustrated by (a)  $+2 + +3 = +5$ , (b)  $+5 + -3 = +2$ , (c)  $+3 + -5 = -2$ , (d)  $-2 + -3 = -5$ . The dashed rectangles indicate the starting and ending location of the black circles which are to be moved between the first and second panels.

addition of positive and negative integers then correspond to ‘honest’ additions of large natural numbers, that is without recourse to the rules of signs, for example,  $+5 + -8 = -3$  becomes  $\$2,000,005 + \$3,999,992 = \$5,999,997$ . The rules of subtraction can also be verified as subtractions of large natural numbers, provided we are careful only to subtract a smaller number of millions, for example  $-3 - -5 = +2$  becomes  $\$3,999,997 - \$1,999,995 = \$2,000,002$ . The multiplication of positive and negative integers can be checked the same way, except that to avoid overflowing the display of the calculator it is better to switch to whole numbers of thousands rather than millions, then  $-3 \times +2 = -6$  becomes  $1,997 \times 2,002 = 3,997,994$ , while  $-4 \times -2 = +8$  becomes  $2,996 \times 1,998 = 5,986,008$ .

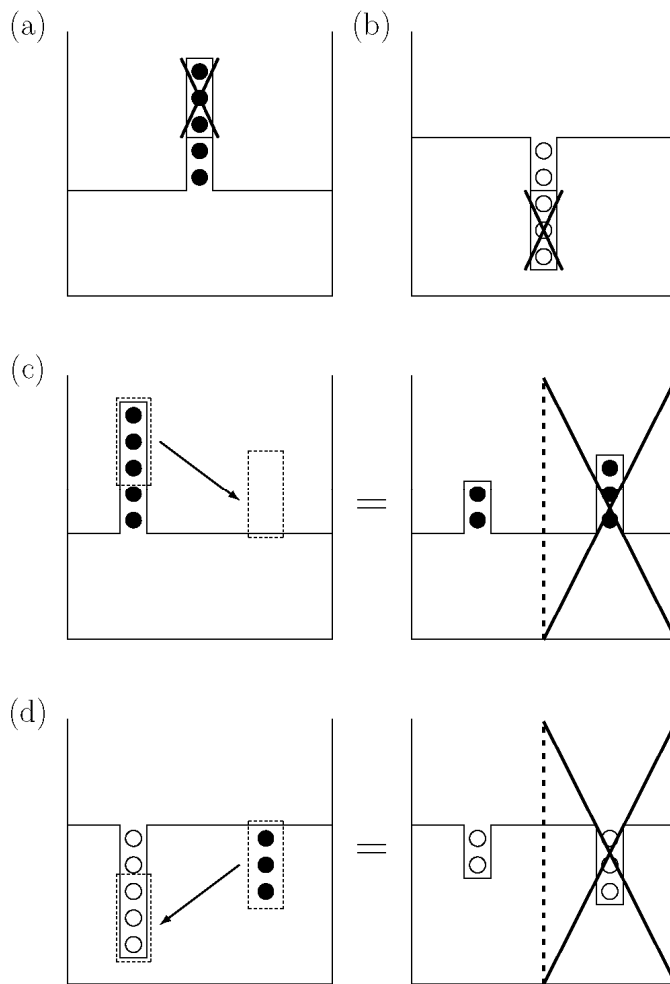
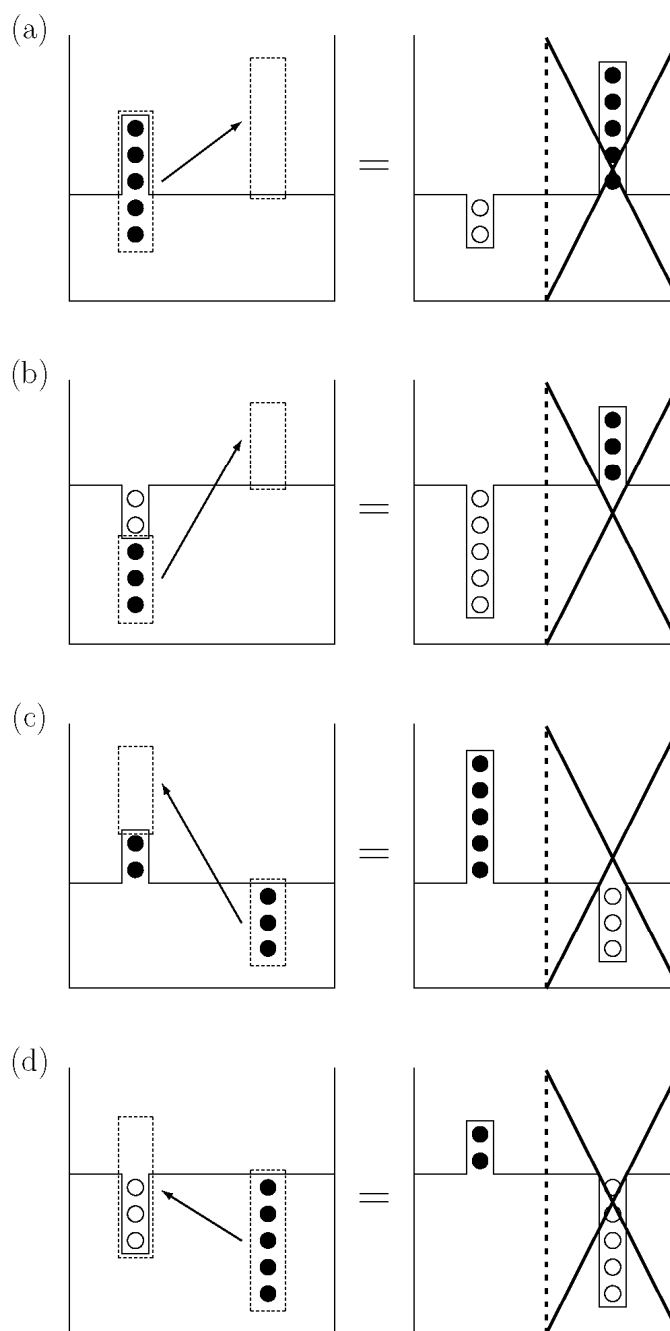

Figure 7. The two easiest cases of subtraction of integers computed using the banking model, illustrated incorrectly by (a)  $+5 - +3 = +2$ , (b)  $-5 - -3 = -2$ , then correctly by (c)  $+5 - +3 = +2$ , (d)  $-5 - -3 = -2$ , where the equals signs (=) represent what is true immediately before the subtraction is carried out, indicated by a **X**.



*Figure 8.* The other four cases of subtraction of integers computed using the banking model, illustrated by (a)  $+3 - +5 = -2$ , (b)  $-2 - +3 = -5$ , (c)  $+2 - -3 = +5$ , (d)  $-3 - -5 = +2$ , where the equals signs (=) represent what is true immediately before the subtraction is carried out, indicated by a **X**.

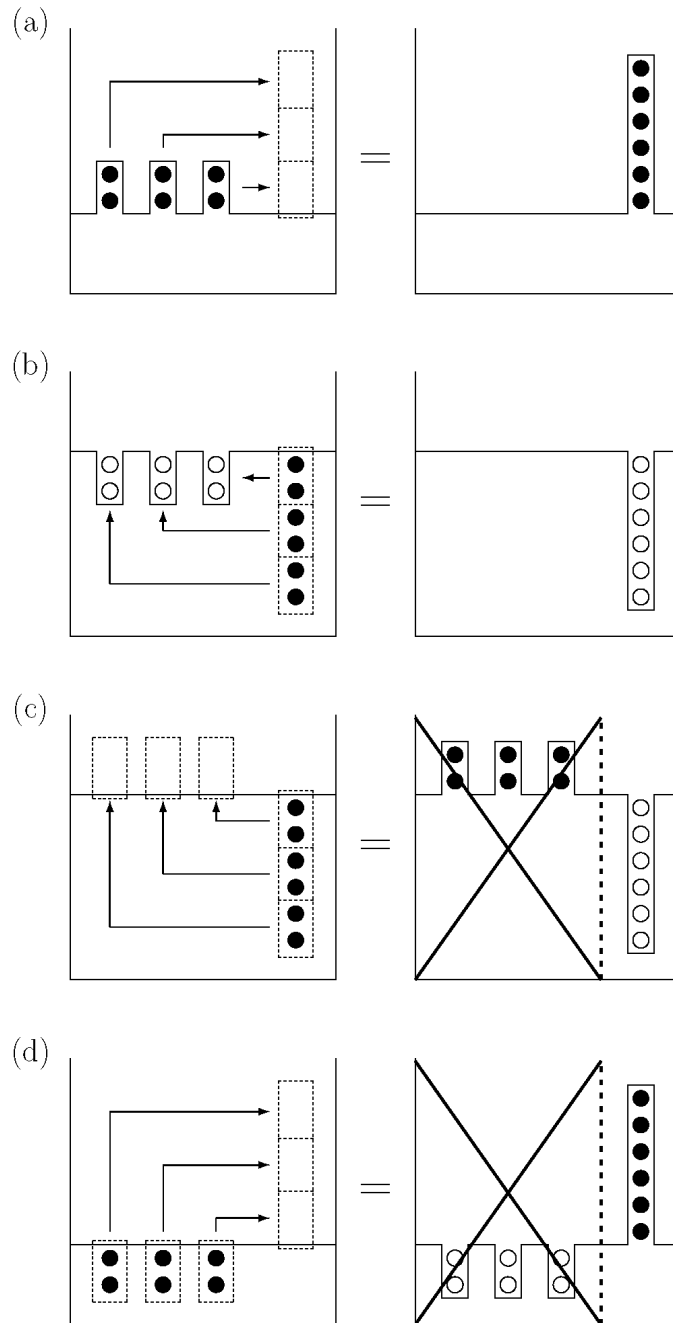

Figure 9. The four different cases of multiplication of integers computed using the banking model, illustrated by (a)  $+3 \times +2 = +6$ , (b)  $+3 \times -2 = -6$ , (c)  $-3 \times +2 = -6$ , (d)  $-3 \times -2 = +6$ , where multiplication by a positive is interpreted as repeated addition, while multiplication by a negative is interpreted as repeated subtraction.

$$R_1 : 2x + y + 0 = 1$$

$$R_2 : 0 + 3y + z = 1$$

$$R_3 : x + 0 + 4z = 1$$

$T =$  total of all three rows

$$T : 3x + 4y + 5z = 3$$

$$R_i \rightarrow R_i + 1000T$$

$$R_1 : 3002x + 4001y + 5000z = 3001$$

$$R_2 : 3000x + 4003y + 5001z = 3001$$

$$R_3 : 3001x + 4000y + 5004z = 3001$$

$$R_3 \rightarrow 2R_3 - R_1$$

$$R_1 : 3002x + 4001y + 5000z = 3001$$

$$R_2 : 3000x + 4003y + 5001z = 3001$$

$$R_3 : 3000x + 3999y + 5008z = 3001$$

$$R_3 \rightarrow 3R_3 + R_2$$

$$R_1 : 3002x + 4001y + 5000z = 3001$$

$$R_2 : 3000x + 4003y + 5001z = 3001$$

$$R_3 : 12,000x + 16,000y + 20,025z = 12,004$$

$$R_i \rightarrow R_i - ? \times 1000T$$

$$R_1 : 2x + y + 0 = 1$$

$$R_2 : 0 + 3y + z = 1$$

$$R_3 : 0 + 0 + 25z = 4$$

*Figure 10.* Problem 3 from Chapter 8 of *The Nine Chapters* and its solution using essentially the same row operations as shown in Figure 1, but where 1000 times the sum of all three original rows (the ‘bank money’) has been added to each row at the start, in order to avoid having to work with negative numbers.

If the whole numbers of millions in each of the ‘honest’ natural number computations in the above proof were replaced by zeroes, the result would be the difference pair computations used to demonstrate the properties of the integers in Part B. This suggests a way to prove the permanence principle for integers, that is, prove that solutions to linear algebra problems obtained via negative numbers are correct, by adding large constants so that all subtractions become completeable. As an example of how such a proof would work, consider the problem taken from *The Nine Chapters* shown in Figure 1, but first add 1000 times the sum of all three

rows to each of the rows, which we know leaves the solutions invariant. Figure 10 then shows exactly the same Gaussian elimination row operations as shown in Figure 1, except that because they now involve only ‘honest’ arithmetic on large natural numbers, since what were previously positive and negative integer coefficients are now small variations about the whole numbers of thousands, the solutions obtained must be correct. Since the thousands will always drop out in the end, we can dispense with them and work just with the uncompleted subtractions alone, and because the steps we will then perform symbolically would have been arithmetical had the thousands been present, the final answers will be correct. The rules of signs for negative numbers therefore simply express how uncompleted subtractions effectively behave if, in the context of problem solving, they are rendered completeable by the inclusion of a sufficiently large additive constant, as summarised in Figure 11(a).

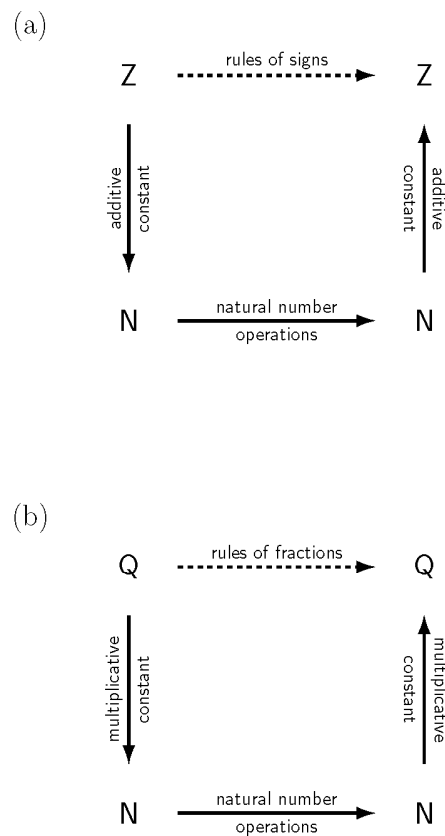

Figure 11. A proof of the permanence principle, where (a) the rules of signs, and (b) the rules of fractions, are converted into operations involving only natural numbers by the inclusion of sufficiently large additive or multiplicative constants, hence any solution obtained via negative or fractional numbers must be correct.

Similarly, the baking model is a true physical model of the rationals, as computations involving fractions become ‘honest’ natural number computations if the measurement ‘unit’ is a large whole number, for example,  $3/4 \text{ kg} \div 1/8 \text{ kg} = 750 \text{ g} \div 125 \text{ g} = 6$ . So we can prove the permanence principle for rationals, that is, show that solutions to a linear algebra problem obtained via fractions are correct, by multiplying by a large constant so as to make all divisions



completeable. A practical example of this is shown in Figure 12, where instead of solving the linear algebra problem using fractions in Figure 12(a), we first multiply all rows by 1000 which we know leaves the solutions unchanged. Figure 12(b) shows the same row operations, except that they now involve only ‘honest’ arithmetic on large natural numbers, since what were previously fractional coefficients are now small multiples below a thousand. Once we know we can always do this, we can dispense with multiplying by a thousand and just deal with the uncompleted divisions alone, regarding the rules of fractions as convenient shorthand for what would happen if the thousands were there. So the properties of fractions simply express how uncompleted divisions would effectively behave if they were rendered completeable, and hence correct, by the inclusion of a sufficiently large multiplicative constant, as shown in Figure 11(b).

$$\begin{aligned}
 \text{(a)} \quad & R_1 : x + y = 7 \\
 & R_2 : 5x + 2y = 20 \\
 & R_2 \rightarrow R_2/5 \\
 & R_1 : x + y = 7 \\
 & R_2 : x + \frac{2}{5}y = 4 \\
 & R_1 \rightarrow R_1 - R_2 \\
 & R_1 : 0 + \frac{3}{5}y = 3 \\
 & R_2 : x + \frac{2}{5}y = 4 \\
 & y = 3 \div \frac{3}{5} = 5 \quad x = 4 - \left\{ \frac{2}{5} \times 5 \right\} = 2
 \end{aligned}$$

$$\begin{aligned}
 \text{(b)} \quad & R_1 : 1000x + 1000y = 7000 \\
 & R_2 : 5000x + 2000y = 20,000 \\
 & R_2 \rightarrow R_2/5 \\
 & R_1 : 1000x + 1000y = 7000 \\
 & R_2 : 1000x + 400y = 4000 \\
 & R_1 \rightarrow R_1 - R_2 \\
 & R_1 : 0 + 600y = 3000 \\
 & R_2 : x + 400y = 4000 \\
 & y = 3000 \div 600 = 5 \quad x = \{4000 - 400 \times 5\} \div 1000 = 2
 \end{aligned}$$

*Figure 12.* A linear algebra problem solved (a) using the arithmetic of rational numbers, and (b) using only natural numbers.

## Conclusion

### A Practical Notation for Difference Pairs

The compact notation for a fraction  $n/m$ , which helps students think of it at least as a mathematical object if not a number, relies on our having two different symbols for division, namely the solidus  $/$  and the division sign  $\div$ . In fact, one could regard the solidus as the spiritual descendent of the ‘unit’ oval in Egyptian fractions, and interpret  $a/b = a \times / \div b$ , for example if  $/ = 1 \text{ kg} = 1000 \text{ g}$  then  $3/4 \text{ kg} = 3 \times 1000 \text{ g} \div 4 = 750 \text{ g}$ . In the same way, the  $a - b$  notation for difference pairs could be improved by inventing another symbol for subtraction, and in this Diophantus precedes us. Having no symbol equivalent to our modern addition sign, Diophantus wrote juxtaposed the terms which he intended to be added, just as today we juxtapose terms to be multiplied. He then collected positive and negative terms into two groups separated by a symbol  $\wedge$  whose origin is debated but which was probably an abbreviation for the Greek word ‘wanting’ (Heath, 1910). So, although Diophantus did not accept negative solutions, in a sense he had a system *more* advanced than integers, since his rules of signs were the generalisations of Equations 1, 2 and 3 to cases where the various terms  $a$ ,  $b$ ,  $c$ ,  $d$  are algebraic *expressions*, not just natural numbers.

A modern equivalent of Diophantus’ notation might be to write  $a - b$  as  $a \wedge b$ , the  $\wedge$  being a cue that  $a \wedge b$  is a single mathematical entity rather than an expression (Rowland, 1982, explored an alternative notation). We could even regard  $\wedge$  as the large additive constant and hence interpret  $a \wedge b = a + \wedge - b$ , for example,  $2 \wedge 5 = 2 + 3,000,000 - 5 = 2,999,997$ . We immediately run in the problem, however, that any difference pair *can* always be reduced to the form  $n \wedge 0$  or  $0 \wedge n$ , which uses more symbols than writing  $+n$  and  $-n$ , so as an alternative notation it does not have the clear superiority necessary to challenge traditional signed numbers. Furthermore, even if a compact notation such as  $a \wedge b$  were successfully introduced, it would still face exactly the same problems described earlier in Part B for fractions. Indeed, these problems are so great that it has even been suggested that fractions should be delayed until Secondary school (Hart, 1981, p. 81), their place taken by decimals for purposes of measurement (Freudenthal, 1973, p. 216). This does, however, suggest the following question: since decimals help prove the permanence principle, by converting rational arithmetic into ‘honest’ natural number computations, what notation for negative numbers corresponding to the decimal notation for fractions would the same reasoning applied to integers give?

Just as  $1/8 = 125/1000 = 0.125$  means rendering division by 8 as multiplication by 125 against a standardised division by 1000, applying the same reasoning to integers would render a subtraction as an addition against a standardised subtraction. In fact, one way to do this should already be familiar to those of us old enough to have been brought up on mathematical tables (Godfrey & Siddons, 1976) rather than electronic pocket calculators, namely *negative logarithms*. The inconvenience of mixing positive and negative logarithms was eased by writing the latter as a negative integer but with a positive decimal, for example,  $-0 \cdot 2357$  would have been listed as  $\bar{1} \cdot 7643$ , which is the difference pair  $0 \cdot 7643 - 1$ . The equivalent for integers would be to render a negative number as a negative power of ten plus the positive difference, for example,  $-34$  would be  $\bar{1}66$ , the difference pair  $66 - 100$ . In general, numbers do not have their leading digits in the same column, so operations involving numbers with leading negative digits would inevitably result in negative digits appearing in different columns. In the next section, therefore, we consider writing difference pairs as single numbers *any* of whose digits, not just the leading digit, can

be either positive or negative.

### Classroom Applications of Difference Pairs

Representing integers as single numbers whose digits are positive or negative, can avoid some of the problems Primary School children encounter using subtraction algorithms (Hart, 1989). For example, when subtracting a larger digit from a smaller, such as the  $5 - 8$  in the units column of  $72545 - 48198$ , rather than borrow from the column above, which is conceptually difficult, children often reverse the subtraction and write  $8 - 5 = 3$  instead. We can turn this weakness into a strength by encouraging children to do exactly this but to write the answer as a negative digit  $5 - 8 = 0 - 3 = \bar{3}$ , or for the subtraction as a whole  $72545 - 48198 = \overline{36453}$ . To restore the answer to standard form we *rectify downwards*, that is, convert each block of negative digits into its nines or tens complement by borrowing 1 from the positive digit above, thus we have  $\overline{36453} = [3 - 1][10 - 6][4 - 1][9 - 5][10 - 3] = 24347$ . This effectively separates digit subtractions within columns, and borrowing between columns, into separate phases, not interleaved as traditionally taught. Separate phases, an idea originally due to Babbage in the context of computers (McLeish, 1991, p. 204), can help children work faster and make fewer errors, is easily shown to be effective in both addition and multiplication (Shutler, 2010), and resembles suggestions made by Nuffield Mathematics (Nuffield, 1969, p. 32).

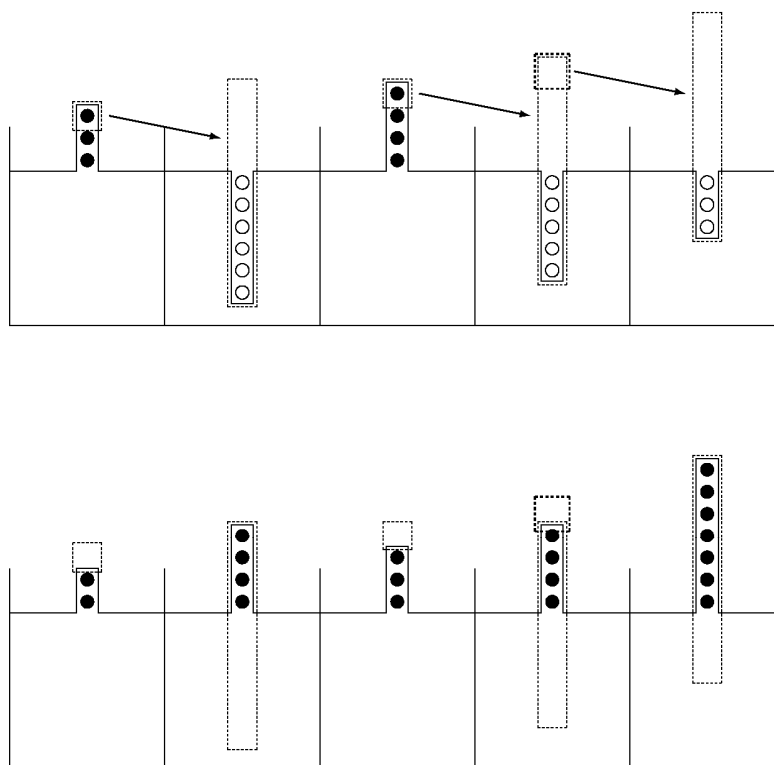

Figure 13. The cash register generalisation of the banking model illustrating the downwards rectification  $\overline{36453} = 24347$ .

The banking model is ideally suited to help children visualise positive and negative digits because it can *parallelise*, that is, represent two or more stacks or wells in parallel before combining them. By contrast, representing integers as arrows on the number line encounters the problem that different arrows may end up superimposed on each other and hence be hard to distinguish, a criticism made by Freudenthal (Freudenthal, 1983, p. 443). Integers with both positive and negative digits can be represented in the *cash register* generalisation of the banking model where, instead of one sandbox filled with \$1 coins, there are several adjacent to each other filled with \$1, \$10, \$100, ..., just as in a traditional retail cash register. Figure 13 shows how the output  $3\overline{6}4\overline{5}3$  from the above subtraction and also its downwards rectification can be represented in the cash register model in a way which makes it easier for children to understand. Arithmetic on whole numbers with both positive and negative digits can clearly be extended without any trouble also to addition and even long multiplication. For example, in the latter case, all one has to do is to extend the notion of times tables in the obvious way to both positive and negative digits e.g.  $\overline{3} \times 6 = \overline{18}$  and  $\overline{4} \times \overline{7} = 28$ .

Writing difference pairs as numbers with both positive and negative digits allows us to express power series such as  $1/(1+x) = 1 - x + x^2 - x^3 + \dots$  as decimal fractions. For example,  $1/(1 \cdot 1)$  is just  $1 \cdot \overline{111111} \dots$  and rectifying gives  $0 \cdot 909090 \dots$ . The Napierian logarithm series  $\ln(1+x) = x - x^2/2 + x^3/3 - \dots$  can also be written as a decimal provided we allow the digits to be fractional as well as negative. Thus  $\ln(1 \cdot 1)$ , an important ingredient in Napier's computation of his logarithm table, is just  $0 \cdot 1 \overline{1/2} \overline{1/3} \overline{1/4} \overline{1/5} \dots$  and rectifying downwards to remove both negatives and fractions (i.e.  $(1 \times 10) + \overline{1/2} = 9\overline{1/2}$ ,  $(\overline{1/2} \times 10) + \overline{1/3} = 5\overline{1/3}$ ,  $(\overline{1/3} \times 10) + \overline{1/4} = 3\overline{1/12}$ , ...) quickly yields  $\ln(1 \cdot 1) = 0 \cdot 095310 \dots$ . Finally, the same is true of the inverse tangent series  $\tan^{-1}(x) = x - x^3/3 + x^5/5 - \dots$  if we expand our notion of decimal fraction to include bases other than base ten, which in particular allows us to write  $\tan^{-1}(1/n) = \{0 \cdot 1 \ 0 \ \overline{1/3} \ 0 \ \overline{1/5} \ 0 \ \overline{1/7} \dots\}_{base \ n}$ . Computing  $\pi$  using well known identities like  $\pi/4 = \tan^{-1}(1/2) + \tan^{-1}(1/5) + \tan^{-1}(1/8)$  is then straightforward, and rectifying downwards yields  $\tan^{-1}(1/5) = \{0 \cdot 1 \ 0 \ \overline{1/3} \ 0 \ \overline{1/5} \ 0 \ \overline{1/7} \dots\}_{five} = \{0 \cdot 044314 \dots\}_{five}$ . The standard algorithm for converting to base ten (repeatedly multiplying by 10 and taking the integer part) yields a spigot algorithm more easily than those given in the literature (Rabinowitz & Wagon, 1995).

## Final Thoughts

We end by reviewing each of the three strands with which this article began. First, the lesson of history is that extended number systems are best introduced in the context of problem solving, a view with which Early Algebra research agrees (Carraher *et al.*, 2008). The use of negative numbers in China, and imaginary numbers in Europe, was thus more easily accepted because the equations being solved had solutions that were real and positive, and hence the

results obtained through the use of these extended number systems could be checked for correctness. The equations which caused controversy in Europe were ones whose solutions were negative or imaginary, hence could not be checked because the practical problems being represented were insoluble (Sesiano, 1985). Unfortunately, problems of the former type, such as the solution of cubic polynomials or simultaneous linear equations, are more advanced and hence fall later in the school syllabus, often leading to their being omitted entirely. Students generally encounter extended number systems first in problems of the latter type, such as the solution of quadratic polynomials or simple linear equations, but if the solutions are negative or imaginary the practical problem must be insoluble, hence the mathematics is reduced to purposeless algebraic manipulation. The parts of the school syllabus where extended number systems are introduced are therefore best delayed until children are ready to tackle the problems which these extended number systems were originally created to solve.

Second, extended number systems are best introduced symbolically, not abstractly as is currently the norm in teaching. Thus negative and imaginary numbers were first introduced in Europe as uncompleted arithmetic expressions, which from a modern computer science perspective is perfectly rigorous, since numbers are nothing more than strings of symbols manipulated according to certain rules. Nevertheless, a perceived lack of rigour led to their replacement by ordered pairs under an equivalence relation, which merely shifts the meaning out of the symbols and into the surrounding sentences and paragraphs. Unlike the traditional signed number approach, which at least retains the natural numbers as a subset, the ordered pairs approach to integers replaced the natural numbers wholesale by objects which did not resemble numbers at all, and failed in practice. By contrast, a symbolical approach based on difference pairs involves concrete arithmetic expressions which Early Algebra research shows even young children can understand and manipulate correctly. Thus, abstract approaches do not have a monopoly on rigour in mathematics, and more effort should be invested into researching other approaches which are equally rigorous but easier for children to learn.

Third, physical models should play a more important role in the introduction of extended number systems than just checking computational accuracy or the validation of conceptual understanding. Indeed one could even argue in the spirit of Klein (1968, p. 3) that physical models are the principal motivation for developing mathematics, and that extended number systems are important primarily as a means of describing them. Thus the early development of fractions in the Ancient World can be seen to have been primarily due to their usefulness in describing quantities of physical matter, atoms being so small that any amount of substance can effectively be arbitrarily divided. By contrast, the tardiness with which negative numbers were accepted in Europe might be traced back to the fact that the discovery of actual positive and negative charges was a relatively late event in modern science, indeed the banking model can be seen as simply Dirac's model of the anti-electron thinly disguised. In both of these cases, it was the physical reality that guided us towards a proof of the permanence principle, whereby fractions and negatives were embedded inside the natural numbers, rather than the other way around, so that the divisions and subtractions could be completed. A final, unanswered question is therefore in what way complex numbers can be constructed as a subset of the natural numbers, the answer perhaps lying in the realm of quantum mechanics, where imaginary quantities do indeed have a physical reality.

## References

- Almeida, R. & Bruno, A. (2014) Strategies of pre-service primary school teachers for solving addition problems with negative numbers. *International Journal of Mathematical Education in Science and Technology* **45**(5), 719–737.
- Altıparmak, K. & Özdoğan, E. (2010) A study on the teaching of the concept of negative numbers. *International Journal of Mathematical Education in Science and Technology* **41**(1), 31–47.
- Ashlock, R.B. & West, T. A. (1967) Physical representations for signed-number operations. *The Arithmetic Teacher* **14**(7), 549–554.
- Bartolini, P. (1976) Addition and subtraction of directed numbers. *Mathematics Teaching* **74**, 34–35.
- Bastable, V. & Schifter, D. (2008) Classroom stories: Examples of elementary students engaged in early algebra. In Kaput, J. J., Carragher, D. W. & Blanton, M. L. (Eds.) *Algebra in the Early Grades*, pp. 165–184. New York: Taylor and Francis.
- Behrend, J. L. & Mohs, L. C. (2006) From simple questions to powerful connections: A two-year conversation about negative numbers. *Teaching Children Mathematics* **12**(5), 260–264.
- Bishop, J. P., Lamb, L. L. C., Philipp, R. A., Schappell, B. P. & Whitacre, I. (2011) First graders outwit a famous mathematician. *Teaching Children Mathematics* **17**(6), 350–358.
- Bishop, J. P., Lamb, L. L., Philipp, R. A., Whitacre, I., Schappelle, B. P. & Lewis, M. L. (2014) Obstacles and affordances for integer reasoning: An analysis of children's thinking and the history of mathematics. *Journal for Research in Mathematics Education* **45**(1), 19–61.
- Bofferding, L. (2010) Addition and subtraction with negatives: Acknowledging the multiple meanings of the minus sign. In Brosnan, P., Erchick, D. B. & Flevares, L. (Eds.) *Proceedings of the 32nd Annual Meeting of the North American Chapter of the International Group for the Psychology of Mathematics Education; 2010 Oct 28–31; Columbus, OH*. pp. 703-710.
- Bofferding, L. (2014) Negative integer understanding: Characterizing first graders' mental models. *Journal for Research in Mathematics Education* **45**(2), 194–245.
- Bruno, A. & Martínón, A. (1999) The teaching of numerical extensions: the case of negative numbers. *International Journal of Mathematical Education in Science and Technology* **30**(6), 789–809.
- Campbell, H. E. (1970) *The Structure of Arithmetic*. New York: Meredith.
- Cambridge (1963) *Goals for School Mathematics: The Report of the Cambridge Conference on School Mathematics*. Boston, MA: Houghton Mifflin Company.
- Carr, K. & Katterns, B. (1984) Does the number line help? *Mathematics in School* **13**(4), 30–34.
- Carragher, D. W., Schliemann, A. D., Brizuela, B. M. & Earnest, D. (2006) Arithmetic and algebra in early mathematics education. *Journal for Research in Mathematics Education* **37**(2), 87-115.

- Carraher, D. W. & Schliemann, A. D. (2007) Early algebra and algebraic reasoning. In Lester, F. K. (Ed.) *NCTM Second Handbook of Research on Mathematics Teaching and Learning*, pp. 669–705. Charlotte, NC: Information Age Publishing.
- Carraher, D. W., Schliemann, A. D. & Schwartz, J. L. (2008) Early algebra is not the same as algebra early. In Kaput, J. J., Carraher, D. W. & Blanton, M. L. (Eds.) *Algebra in the Early Grades*, pp. 235–272. New York: Taylor and Francis.
- Chace, A. B. (1979) *The Rhind Mathematical Papyrus*. Reston, VA: NCTM Classics in Mathematics Education v.8.
- Cockcroft (1982) *Mathematics Counts: Report of the Committee of Inquiry into the Teaching of Mathematics in Schools under the Chairmanship of Dr WH Cockcroft*. London: HMSO.
- Connect Four [http://en.wikipedia.org/wiki/Connect\\_four](http://en.wikipedia.org/wiki/Connect_four)
- Cotter, S. (1969) Charged particles: A model for teaching operations with directed numbers. *The Arithmetic Teacher* **16**(5), 349–353.
- Domoney, B. (2002) Student teachers' understanding of rational number: part-whole and numerical constructs. *Research in Mathematics Education* **4**(1), 53–67.
- Empson, S. B., Levi, L. & Carpenter, T. P. (2011) The algebraic nature of fractions: Developing relational thinking in elementary school. In Cai, J. & Knuth, E. (Eds.) *Early Algebraization*, pp. 409–428. Berlin: Springer-Verlag.
- Empson, S. B. & Levi, L. (2011) *Extending Children's Mathematics: Fractions and Decimals*. Portsmouth, NH: Heinemann.
- Ernest, P. (1985) The number line as a teaching aid. *Educational Studies in Mathematics* **16**, 411–424.
- Fischbein, E. (1987) *Intuition in science and mathematics*. Dordrecht: D. Reidel.
- Franke, M. L., Carpenter, T. P. & Battey, D. (2008) Content matters: Algebraic reasoning in teacher professional development. In Kaput, J. J., Carraher, D. W. & Blanton, M. L. (Eds.) *Algebra in the Early Grades*, pp. 333–359. New York: Taylor and Francis.
- Freudenthal, H. (1973) *Mathematics as an Educational Task*. Dordrecht: D. Reidel.
- Freudenthal, H. (1983) *Didactical Phenomenology of Mathematical Structures*. Dordrecht: D. Reidel.
- Galbraith, M. J. (1974) Negative numbers. *International Journal of Mathematical Education in Science and Technology* **5**(1), 83–90.
- Gallardo, A. (2002) The extension of the natural-number domain to the integers in the transition from arithmetic to algebra. *Educational Studies in Mathematics* **49**, 171–192.
- Gibbs, R. A. (1977) Holes and plugs. *Mathematics Teaching* **81**, 19–21.

- Gillings, R. J. (1962) Problems 1 to 6 of the Rhind Mathematical Papyrus. *The Mathematics Teacher* **55**(1), 61–69.
- Godfrey, C, & Siddons, A. W. (1976) *Four-Figure Tables*. Cambridge: CUP.
- Griffiths, H. B. & Hilton P. J. (1970) *A Comprehensive Textbook of Classical Mathematics: A Contemporary Interpretation*. London: Van Nostrand Reinhold.
- Hamilton, W. R. (1837) Theory of conjugate functions, or algebraic couples; with a preliminary and elementary essay on algebra as the science of pure time. *Transactions of the Royal Irish Academy* **17**, 293–422.
- Hart, K. M. (1981) Fractions. In Hart, K. M. (Ed.) *Children's Understanding of Mathematics: 11–16. A Report of the Concepts in Secondary Mathematics and Science (CSMS) Project*, pp. 66–81. London: John Murray.
- Hart, K. (1989) Place Value: Subtraction. In Johnson, D. C. (Ed.) *Children's Mathematical Frameworks 8–13: A Study of Classroom Teaching*, pp. 8–45. Windsor: NFER–NELSON.
- Heath, T. L. (1910) *Diophantus of Alexandria: A Study in the History of Greek Algebra*. 2nd ed. Cambridge: CUP.
- Heffer, A. (2011) Historical objections against the number line. *Science & Education* **20**, 863–880.
- Hefendehl-Hebeker, L. (1991) Negative numbers: Obstacles in their evolution from intuitive to intellectual constructs. *For the Learning of Mathematics* **11**(1), 26–32.
- Hitchcock, G. (1997) Teaching the negatives, 1870–1970: A medley of models. *For the Learning of Mathematics* **17**(1), 17–25.
- Hughes, P. G. (2012) *Negative Numbers*. University of Auckland.  
<http://schools.reap.org.nz/advisor/Latest%20Lomas/Chapxx%20Negative%20.pdf>
- Hunter, J., Monk, D., Blackburn, W. T. & Donald, D. (1971) *Algebra and Number Systems*. Glasgow: Blackie.
- Hollings. C. (2014) Embedding semigroups in groups: not as simple as it might seem. *Archive for History of Exact Sciences* **68**(5), 641–692.
- Jacobs, V. R., Franke, M. L., Carpenter, T. P., Levi, L. & Battey, D. (2007) Professional development focussed on children's algebraic reasoning in elementary school. *Journal for Research in Mathematics Education* **38**(3), 258–288.
- Kaner, P. A. (1964) The addition and subtraction of negative numbers. *The Mathematical Gazette* **48**(364), 183–185.
- Kaput, J. J. (2008) What is algebra? What is algebraic reasoning? In Kaput, J. J., Carragher, D. W. & Blanton, M. L. (Eds.) *Algebra in the Early Grades*, pp. 5–17. New York: Taylor and Francis.



- Katz, V. J. (2009) *A History of Mathematics: An Introduction*. 3rd ed. Boston, MA: Addison-Wesley.
- Keedy, M. L. (1969) *A Modern Introduction to Basic Mathematics*. 2nd ed. Reading, MA: Addison-Wesley.
- Kerslake, D. (1986) *Fractions: Children's Strategies and Errors. A Report of the Strategies and Errors in Secondary Mathematics (SESM) Project*. Windsor: NFER–NELSON.
- Klein, J. (1968) *Greek Mathematical Thought and the Origin of Algebra*. Cambridge, MA: MIT Press.
- Küchemann, D. (1981) Positive and negative numbers. In Hart, K. M. (Ed.) *Children's Understanding of Mathematics: 11–16. A Report of the Concepts in Secondary Mathematics and Science (CSMS) Project*, pp. 82–87. London: John Murray.
- Lamb, L. L., Bishop, J. P., Philipp, R. A., Schappelle, B. P., Whitacre, I. & Lewis, M. (2012a) Developing symbol sense for the minus sign. *Mathematics Teaching in the Middle School* **18**(1), 5–9.
- Lamb, L. L., Bishop, J. P., Philipp, R. A., Schappelle, B. P., Whitacre, I. & Lewis, M. (2012b) High school students' conceptions of the minus sign. *Mathematics Teaching* **227**, 40–44.
- Leddy, T. (1977) Mis-directed numbers. *Mathematics Teaching* **78**, 26–29.
- Leong, Y. H., Tay, E. G., Quek, K. S., Yap, S. F., Tong, C. L., Toh, W. Y. K., Irni Karen Bt M. Z., Chia, A., Ong, Y. T., Nur Illya Nafiza M., Au-Chew, K. (2014) Redesigning a module on addition and subtraction involving negative numbers. *Mathematics Teaching* **241**, 47–50.
- Liebeck, P. (1990) Scores and forfeits – an intuitive model for integer arithmetic. *Educational Studies in Mathematics* **21**, 221–239.
- McLeish, J. (1991) *Number*. London: Bloomsbury.
- Martínez, A. A. (2006) *Negative Math: How Mathematical Rules can be Positively Bent*. Cambridge, MA: Princeton University Press.
- Martzloff, J-C. (1997) *A History of Chinese Mathematics*. Berlin: Springer-Verlag.
- Mason, J. (2008) Making use of children's powers to produce algebraic thinking. In Kaput, J. J., Carraher, D. W. & Blanton, M. L. (Eds.) *Algebra in the Early Grades*, pp. 57–94. NCTM
- Mendelson, E. (1973) *Number Systems and the Foundations of Analysis*. New York: Academic Press.
- Netz, R. & Noel, W. (2007) *The Archimedes Codex*. London: Weidenfeld & Nicolson.
- New Zealand (2014) Hills and Dales <http://nzmaths.co.nz/resource/hills-and-dailes>
- Nuffield (1969) Nuffield Mathematics Project. *Computation and Structure* ④. New York: Wiley.

- Peacock, G. (1842) *A Treatise on Algebra Volume I: Arithmetical Algebra*. Cambridge: CUP.
- Peacock, G. (1845) *A Treatise on Algebra Volume II: Symbolical Algebra*. Cambridge: CUP.
- Peled, I. & Carraher, D. W. (2008) Signed numbers and algebraic thinking. In Kaput, J. J., Carraher, D. W. & Blanton, M. L. (Eds.) *Algebra in the Early Grades*, pp. 303-327. New York: Taylor and Francis.
- Phillips, D. *George Peacock and the Development of British Algebra 1800-1840*. University of Cambridge, Faculty of Mathematics, Summer Undergraduate Research Reports. [http://www.maths.cam.ac.uk/careers/undergrad\\_summer\\_research/Phillips.pdf](http://www.maths.cam.ac.uk/careers/undergrad_summer_research/Phillips.pdf)
- Pycior, H. M. (1981) George Peacock and the British origins of symbolical algebra. *Historia Mathematica* **8**, 23–45.
- Pycior, H. M. (1982) Early criticisms of the symbolical approach to algebra. *Historia Mathematica* **9**, 392–412.
- Rabinowitz, S. & Wagon, S. (1995) A spigot algorithm for the digits of  $\pi$ . *American Mathematical Monthly* **102**(3), 195-203.
- Rappaport, D. (1971) The Nuffield Mathematics Project. *The Elementary School Journal* **71**(6), 295–308.
- Robson, E. (2002) Words and pictures: New light on Plimpton 322. *American Mathematical Monthly* **109**(Feb), 105–120.
- Rowland, T. (1982) Teaching directed numbers: An experiment. *Mathematics in School* **11**(1), 24–27.
- Russell, S. J., Schifter, D. & Bastable, V. (2009) *Research: Algebra in the Revision*. In *Greater Than: A Prepublication Report. Investigations in Number, Data and Space*. Pearson. <https://investigations.terc.edu/library/curric-math/algebrairevision.pdf>
- Russell, S. J., Schifter, D. & Bastable, V. (2011a) Developing algebraic thinking in the context of arithmetic. In Cai, J. & Knuth, E. (Eds.) *Early Algebraization*, pp. 43–69. Berlin: Springer–Verlag.
- Russell, S. J., Schifter, D. & Bastable, V. (2011b) *Connecting Arithmetic to Algebra: Strategies for Building Algebraic Thinking in the Early Grades*. Portsmouth, NH: Heinemann.
- Sawyer, W. W. (1964) *Vision in Elementary Mathematics*. Mineola, NY: Dover.
- Schifter, D., Monk, S., Russell, S. J. & Bastable, V. (2008) Early algebra: What does understanding the laws of arithmetic mean in the elementary grades? In Kaput, J. J., Carraher, D. W. & Blanton, M. L. (Eds.) *Algebra in the Early Grades*, pp. 413–447. New York: Taylor and Francis.
- Selter, C., Prediger, S., Nührenbörger, M. & Hußmann, S. (2012) Taking away and determining the difference – a longitudinal perspective on two models of subtraction and the inverse relation to addition. *Educational Studies in Mathematics* **79**, 389–408.

- Sesiano, J. (1985) The appearance of negative solutions in mediaeval mathematics. *Archive for History of Exact Sciences* **32**, 105–150.
- Shen, K-S., Crossley, J. N. & Lun, A. W. C. (1999) *The Nine Chapters on the Mathematical Art: Companion and Commentary*. Oxford: OUP.
- Shutler, P. M. E. (2010) Predator Arithmetic. *International Journal of Mathematical Education in Science and Technology* **41**(1), 69–79.
- Skemp, R. R. (1976) Relational understanding and instrumental understanding. *Mathematics Teaching* **77**, 20–26.
- Southampton (1961) *On Teaching Mathematics: A report on some present-day problems in the teaching of mathematics, being the outcome of discussions and lectures at the Southampton Mathematical Conference 1961, under the Chairmanship of Bryan Thwaites*. Oxford: Pergamon Press.
- Standards (1989) *Curriculum and Evaluation Standards for School Mathematics*. Reston, VA: National Council of Teachers of Mathematics.
- Thomaidis, Y. & Tzanakis, C. (2007) The notion of historical “parallelism” revisited: Historical evolution and students’ conception of the order relation on the number line. *Educational Studies in Mathematics* **66**, 165-183.
- Temperley, E. W. P. (1912) The introduction to the idea of a negative number. *The Mathematical Gazette* **6**(99), 339–340.
- Ulrich, C. (2012) The addition and subtraction of signed quantities. Wisdome technical report. [http://www.uwyo.edu/wisdome/\\_files/documents/ulrich.pdf](http://www.uwyo.edu/wisdome/_files/documents/ulrich.pdf)
- Vlassis, J. (2008) The role of mathematical symbols in the development of number conceptualization: The case of the minus sign. *Philosophical Psychology* **21**(4), 555–570.
- Wilcox, V. B. (2008) Questioning zero and negative numbers. *Teaching Children Mathematics* **15**(4), 202–206.
- Whitacre, I., Bishop, J. P., Lamb, L. L. C., Philipp, R. A., Schappelle, B. P. & Lewis, M. L. (2012) Happy and sad thoughts: An exploration of children’s integer reasoning. *The Journal of Mathematical Behaviour* **31**, 356–365.
- Wikipedia <http://en.wikipedia.org/wiki/Integer>