

University of Montana

## ScholarWorks at University of Montana

---

Graduate Student Theses, Dissertations, &  
Professional Papers

Graduate School

---

1993

### It's a M.U.D. M.U.D. M.U.D. M.U.D. world!: Experiments in self-reliance at the Missoula Urban Demonstration Project

Mark Waltermire

*The University of Montana*

Follow this and additional works at: <https://scholarworks.umt.edu/etd>

**Let us know how access to this document benefits you.**

---

#### Recommended Citation

Waltermire, Mark, "It's a M.U.D. M.U.D. M.U.D. M.U.D. world!: Experiments in self-reliance at the Missoula Urban Demonstration Project" (1993). *Graduate Student Theses, Dissertations, & Professional Papers*. 5270.

<https://scholarworks.umt.edu/etd/5270>

This Thesis is brought to you for free and open access by the Graduate School at ScholarWorks at University of Montana. It has been accepted for inclusion in Graduate Student Theses, Dissertations, & Professional Papers by an authorized administrator of ScholarWorks at University of Montana. For more information, please contact [scholarworks@mso.umt.edu](mailto:scholarworks@mso.umt.edu).

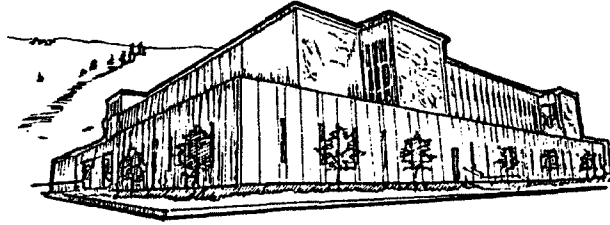

# Maureen and Mike MANSFIELD LIBRARY

The University of  
**Montana**

---

Permission is granted by the author to reproduce this material in its entirety, provided that this material is used for scholarly purposes and is properly cited in published works and reports.

**\*\* Please check "Yes" or "No" and provide signature\*\***

Yes, I grant permission

No, I do not grant permission

Author's Signature

Maureen and Mike Mansfield

Date: 17 Dec. 1993

Any copying for commercial purposes or financial gain may be undertaken only with the author's explicit consent.

It's a  
M.U.D., M.U.D.,  
M.U.D., M.U.D.  
World!

EXPERIMENTS IN SELF-RELIANCE  
AT THE MISSOULA URBAN DEMONSTRATION PROJECT

by Mark Waltermire

Presented in partial fulfillment of the requirements for the degree of  
Master of Science in Environmental Studies  
University of Montana  
1993

Approved by

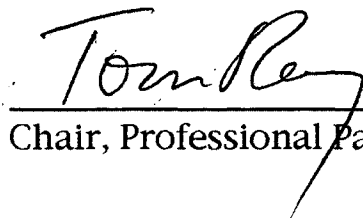

Chair, Professional Paper Committee



Dean, Graduate School

Dec. 28, 1993  
Date

UMI Number: EP40734

All rights reserved

INFORMATION TO ALL USERS

The quality of this reproduction is dependent upon the quality of the copy submitted.

In the unlikely event that the author did not send a complete manuscript and there are missing pages, these will be noted. Also, if material had to be removed, a note will indicate the deletion.



UMI EP40734

Published by ProQuest LLC (2014). Copyright in the Dissertation held by the Author.

Microform Edition © ProQuest LLC.

All rights reserved. This work is protected against unauthorized copying under Title 17, United States Code



ProQuest LLC.  
789 East Eisenhower Parkway  
P.O. Box 1346  
Ann Arbor, MI 48106 - 1346

TABLE OF CONTENTS

FOREWORD ..... 1

COMPOST — DO THE ROT THING ..... 7

    Compost Builds a Better Garden ..... 7

    My God, It's Alive! ..... 10

    Get It Cookin' ..... 12

    What to Toss In, and What to Toss Out ..... 15

    Bins, Bags or Sheets— Find a Form to Fit the Function ..... 17

    We Have Worms and You Can Too. .... 21

DO YOURSELF A FAVA — TRY GARDENING IN MISSOULA ..... 29

    Picking a Plot ..... 30

    Successful Seeds and Healthy Starts ..... 34

    Crops That Thrive ..... 36

    Climate-Induced Gardening Tips ..... 45

NON-TOXIC LAWN CARE — MAKE THE GRASS GREENER ON YOUR  
SIDE OF THE FENCE ..... 48

    I Know It's Just a Lawn, but Where Do We Put It? ..... 48

    The Dirt on Soil ..... 49

    Variety Is the Spice of Lawns ..... 50

    Seed Money ..... 51

    Grass Crowns and Weed Seeds ..... 52

    Tall Blades and Even Cuts ..... 54

    Don't Feed the Lawns ..... 57

    Long Drinks, Not Short Sips ..... 58

    Quackgrass and Webworms and Grubs, Oh My! ..... 60

SOME SAGE ADVICE ABOUT NATIVE-PLANT LANDSCAPING ..... 63

    Why? Because We Like Them ..... 64

    How to Swap Bunchgrass for Bluegrass ..... 67

    Weeding, Watering (and Awithmatic) ..... 72

STOP THE DRAFT! WEATHERIZE YOUR HOME ..... 75

    More Bats, Less Fueling — Insulating Your Home ..... 75

    Vapor Barriers ..... 77

    What to Insulate ..... 78

    How to Insulate ..... 80

    Gone with the Wind ..... 83

    Free Help ..... 85

ALTERNATIVE ENERGY — GIZMOS AND GADGETS THAT SAVE  
ENERGY AND MONEY ..... 88

    Choosing Alternative Technologies ..... 89

    Electricity from Sunlight ..... 89

    Compact Florescent Light Bulbs ..... 92

    Electricity from the Wind ..... 93

    Getting Aggressive about Passive Solar — Solar Heater,  
Solar Oven and Solar Food Dryer ..... 94

    Alternative Bathroom Technologies — On-Demand Water  
Heater and Toilet-Lid Sink ..... 100

    Home-Built Bike Cart and Studded Bike Tire ..... 105

AFTERWORD ..... 108

Page 1-7-94

## LIST OF ILLUSTRATIONS

PALLET BIN	18
GRASS PLANT VS. WEED PLANT	52
BLUEBUNCH WHEATGRASS	65
VAPOR BARRIERS AND INSULATION	80
PASSIVE SOLAR SYSTEM	95
SOLAR OVEN	99
SOLAR FOOD DRYER	100
TOILET LID SINK	103
HOME-BUILT BIKE CART	105
STUDDED TIRE	106

## FOREWORD

When you finally stumble across the Missoula Urban Demonstration project after meandering through the odd mix of comfortably worn houses of the Northside, you'll find two mostly rebuilt houses, both slightly the worse for wear, fronted by beds of bunchgrass, sage and other native plants that contrast strongly with the close-cropped grass lawns of the neighbors. Solar panels are leashed with wires to one of the houses, and a solar greenhouse sits behind the other. You'll see a backyard filled with vegetable beds, herbs, flowers, fruit trees and other plants. A string of compost bins take up a good portion of the back fence line of the property, separated from the railroad switching yard by a gravel alley and a large pile of scrap iron owned by the neighbors. The remainder of the land houses a small cottage that serves as the project office, two storage sheds filled with gardening gear and salvaged building products, and a rack filled with scavenged lumber.

The M.U.D. project serves as a site for individuals to experiment with and demonstrate self-reliant living skills. My involvement in the M.U.D. project, and its objective of self-reliance, comes as both a response to and product of my upbringing.

I grew in middle-class suburbia, exposed to middle-class suburban values. My parents practiced some of the traditional self-reliance passed on to them by their parents, but with a contemporary twist. We visited my grandfather's truck farm in the summers, helping pick raspberries, cherries, apples and vegetables. My siblings and I learned the joy of pelting each other with rotting

tomatoes as we picked them, and of building tiny dams in the irrigation water. We also learned the different taste of home-grown corn, and how raspberries are best picked at dawn.

Back in suburbia, I learned to take comfort from a pantry stocked with both home-canned vegetables and containers of Tang and instant cheesecake mix. My parents always maintained a backyard vegetable and fruit garden, but let Ortho stock the gardening shelves with pesticides to blast slugs, aphids and other pests, and a wide selection of fertilizers for every plant and season.

I grew up wavering between finding traditional self-reliant skills time-consuming chores I could easily discard for store-bought replacements, and feeling that those skills held something for me, even if they meant less convenience. I loved plucking fresh peppers off of our backyard plants, and I struggled every year, in vain, to grow a hundred-pound giant pumpkin for Halloween. As much as I enjoyed vacations to my grandfather's farm, I thought a full summer there, getting up at five in the morning to lug irrigation pipe to the corn field, sounded dreadful. And as much as I enjoyed the farm food on our visits, I still sneaked boxes of Nilla Wafers and bottles of Dr. Pepper into my room to snack on before bed.

After leaving home I found myself slowly swallowed into contemporary American culture. I felt pushed away from taking care of myself and pushed toward reliance on anonymous, corporate others to sell me food, clothing, transportation, shelter and energy. I was told to value comfort and convenience, with pre-packaged processed foods, a huge house filled with electronic devices and even consumptive entertainment, sitting idly in front of a television or



movie screen having no involvement other than ingesting what others provided.

I had no garden, no compost bin and nothing other than utility bills to interest me in cutting my energy use. But I had an unsettled feeling about living the way I did.

I later escaped the US to see others' cultures and lifestyles, prompting me to more deeply consider the personal and environmental implications of the lifestyle I choose. I saw more directly how the environment, both human and physical, suffers when its inhabitants lack of self-reliance. I began to recognize how the large-scale mechanized agriculture that supplies most store-bought food relies on fertilizers, pesticides and petroleum, taking its toll on air, water, soil and food quality. I saw how energy-intensive processing offers less-nutritious, potentially health-damaging food.

Here in Missoula I can see how transporting myself, my food, and the other consumer goods I buy swills petroleum and spews pollution. I only need to taste Missoula's winter air to be reminded of this problem. I can see how excessive packaging and frivolous disposable gewgaws deplete resources and create huge amounts of waste.

Homes also take excessive money and resources. I curse clearcuts, but the homes I've lived in have been built with new wood and new construction materials rather than reused or alternative materials. My appliances suck energy from dammed rivers, coal-fired and nuclear power plants, and other costly and polluting sources of power.

By buying mass-produced products made by people I can't see or know, I discourage people from within my community from developing self-reliant skills. I help my own community lose its ability to be self-reliant.

Missoula serves as a good example of this decline in community self-reliance. Here in the Garden City, we've lost the market gardens that lent Missoula its nickname; they've given way to condos and pavement. By purchasing food from chain supermarkets that import the produce of far-away corporate farms, I make it nearly impossible for local growers to live off of their agricultural work. I rarely know who produces my food, how they raise it, or how they treat their workers or the land it comes from. By buying anonymously produced products I take no responsibility for the effects of my purchases.

I've also paid for this reliance with my money and my time. I've felt forced to find jobs that pay enough for me to afford the cost others charge to satisfy my wants and needs. In turn, the jobs sap my time and energy, leaving me too tired to expend the effort to do for myself. Gardening, bicycling and walking, or pulling and pounding nails take time, and many of the technologies upon which I've felt dependent are too complicated for me to understand enough to repair or build, even with the time to try.

As I learn more about the effects of my reliance on anonymous others, I realize that I need to take more responsibility over satisfying my needs and wants. Developing self-reliant living skills gives me a choice — knowing how to do it myself allows me choose how to spend my time and feel more in control of my life. I can grow much of my own food and transport myself more often with my own

power, or with less energy-intensive and polluting means. I can learn how to build and revamp my own shelter, reusing and scavenging building materials to make it more energy efficient and less resource intensive. I can learn how to cut my reliance on the large-scale utility systems and to barter my skills directly with others who have developed their own. And I can share knowledge and skills with others, making my community more self-reliant.

A group of five people, including myself, established the Missoula Urban Demonstration project on property that formerly housed the Down Home Project and spawned Garden City Seeds. We wanted to continue the urban self-reliance work that had characterized the property for the previous ten years and to give people like ourselves a site to develop and demonstrate self-reliant living skills.

It's a work in progress, as it always will be. We're working toward making changes in our lifestyles, just as we're working to make the property become a place to apply the changes. Just as my pantry has home-canned beans next to hot cocoa mix, we have a site that reflects both our ambitions and our still-developing skills. We have extensive backyard gardens with vegetables, fruits, medicinal and culinary herbs; native plant landscaping; water- and energy-saving technologies including home-built bike carts and passive and active solar systems; a solar greenhouse; and an extensive composting operation. We also have plans to build a straw-bale greenhouse (using stucco-covered straw bales as insulation and components of the walls), finish revamping the houses, install more

passive-solar systems and plant more fruit trees, continuing in the direction we've set for ourselves.

We offer a variety of educational programs, including a workshop series on self-reliance topics ranging from organic gardening to solar electric technologies to salvage carpentry. We work in local schools helping kids learn about and participate in native-plant restoration, composting, alternative energy, and gardening.

The M.U.D. project also runs the Northside Community Gardens, where folks without home garden space can raise their own vegetables. At the community gardens we also grow food for the Poverello Center and the Food Bank of Missoula, run gardening classes with the local Head Start school, and run the Garden Program, helping low-income Missoulaans learn how to raise more of their own food.

This collection of articles gives an idea of the replicable activities of the M.U.D. project. I've written them to give others in Missoula an idea of our experiments in self-reliance and our experiences in trying to change our lifestyles, with the hope others will find them useful in their own attempts to live more responsibly.

## COMPOST

### DO THE ROT THING

Build a compost pile? Why? Why create a pile of reeking spoiled food? Why offend my neighbors? Why give neighborhood dogs a chance to indulge themselves in their most disgusting form of dogness — scavenging rotting morsels from my compost heap. Hell, why offend myself, having to step outside my back door and face a foul-smelling mound of putrid detritus?

Stroll through the woods, kick up the leaves and pine needles, and smell the sweet aroma of the forest floor. Reach down and feel the duff, the material under the leaves and needles. The black earth feels cool and moist, and crumbles easily between your fingers. You've found compost.

You can produce compost as sweet smelling as the black squirrel's carpet, and, in your yard, build compost bins as unobtrusive as patio furniture. And your garden craves compost — nothing you can add will help it more in the long run. Your flowers, vegetables and even your lawn will thank you profusely.

#### Compost Builds a Better Garden

Why does a garden crave compost? Think of the forest. Nearly every leaf, needle, twig, berry and flower petal that falls from the forest plants and hits the ground stays there and decomposes. Even the ones eaten by animals decay there as the animal's scat or, when the critter dies, as its body. As the organic matter breaks down, the

nutrients in these materials return to the soil where they're again available to new forest plants.

Now consider your garden. Every time you pull a carrot or trim your lettuce, taking the food away to eat, you remove nutrients. The nutrients in the carrot you eat come from the soil. Removing vegetables from the garden mines it, leaving the soil that much poorer for future plants. Composting your carrot peelings and greens, your leaves, coffee grounds and apple cores, lets you mimic the natural process that goes on in the forest. You can replace the nutrients you remove, leaving the soil in at least as good shape as you found it.

Compost does more than replace lost nutrients. If you garden here in the bed of old Lake Missoula, you've noticed the largest impediments to spading in this valley are the polished round rocks that lurk just under the surface of the soil. Once you remove the rocks, silt from the bottom of the lake or the sediment brought down by the rivers makes up the soil of much of the Missoula Valley. This soil grows knapweed profusely, but doesn't work well for gardens until we help it out. That's where the compost comes in.

Water drains through our soils like iced tea through a bladder. The humus (decomposed organic matter) in compost helps our soils retain moisture by adding structure to the soil. Since most garden plants are native to much wetter climates than the semi-desert of Missoula, they benefit greatly from having more moisture available to them. And you'll have to water less often when your soil stays moist longer.

A mix of broken down plant materials, compost holds all the nutrients necessary for healthy plant growth. Compare the sixteen or so macro- and micro-nutrients plants need for growth contained in compost with the three nutrients found in most commercial plant fertilizers, and you'll opt for the compost. Compost has a timed-release benefit, releasing nutrients to the soil and plant roots slowly. The nutrients, wrapped up in the organic matter, are available to the plants as they need them rather than all at once as with the water-soluble commercial fertilizers.

### Elements Needed by Plants

Macronutrients

Nitrogen

Potassium

Phosphorus

Micronutrients,  
or trace elements

Calcium

Magnesium

Sulfur

Iron

Chlorine

Copper

Manganese

Zinc

Molybdenum

Boron

Compost also helps buffer soil pH — it keeps the soil from becoming too acidic or alkaline. Nutrients undergo chemical changes in both too acidic and too alkaline soil, making them unavailable to plants. Compost makes sure plants can get the nutrients they need.

The humus added by compost improves the tilth, or structure, of the soil, helping plants' roots work their way through the ground, encouraging earthworms and other beneficial organisms to aerate the soil, and reducing erosion.

One more reason to compost: Thirty percent of landfill-bound waste is leaves, grass and other compostable yard waste. By composting all organic matter rather than flushing it into the waste stream we can reduce the amount going to the dump by fifty percent.

My God, It's Alive!

Compost happens. We see it happening in the forest. But how does it happen in our back yards? Well, it's an orgy of countless tiny critters called microbes. When you build a compost pile these critters, present everywhere and hovering around looking for a hunk of food to decompose, dive in.

The first microbes to attack the pile are called psychrophiles, even to their faces. Famished from their long stints of hovering they dig in quickly and furiously reproduce. Before long they, in the processes of living, start to generate a good deal of heat and actually cook themselves out of a home, if the compost pile is large enough to contain the heat (three by three by three feet makes a suitable size



except in the dead of winter). The psychrophiles only tolerate temperatures from 28 to 55 degrees F., which they quickly exceed.

But not to worry, the mesophiles are on the way. Mesophiles live at temperatures between 40 and 110 degrees F., and ably take over from the cool-loving critters. They, too, dive in voraciously and build up a population that, in the process of living and loving, makes a home too hot for them to reside in.

Once again another variety of microbe is ready to move in. This time the thermophiles invade the pile, and really get it steamy. They live at temperatures above 100 degrees F., and won't get cooked out. Head for Yellowstone and you'll find thermophiles in boiling geothermal pools, happily decomposing who knows what, but still there and active. Your compost pile, inhabited by these heat-lovers will reach a temperature of 150 degrees or so within about three days, and stay there for at least a week, after which it will slowly cool down as the microbes eat all the food available to them and leave to hover about again.

But the party in the pile isn't yet over. As the pile cools, actinomycetes, fungi, and various macroorganisms move in to feast on the material left by the microbes, which have broken it down to the point where the larger organisms can feed on it. You may not recognize the name actinomycetes, but you probably recognize their smell. Return again to the forest. That sweet, fungusy smell you get when you kick the duff under the trees comes from these organisms. Look closely at black decomposing plant material, and you'll see white web-like material winding through it. That's they.

Mushrooms and other fungi also help further break down the organic material. And hordes of macroorganisms move in to eat the decaying plant material or to eat other macroorganisms. You can find worms, isopods (sow bugs and pill bugs), springtails, millipedes, beetles, and predatory centipedes in compost piles. And with a properly managed pile, you won't see the larger macroorganisms, the mice and dogs — just keep your compost breaking down quickly, avoid adding meat, cheese or other animal products, and keep a strong frame, like pallets, around the bin.

### Get It Cookin'

How do you get this process moving? Easy. Think decomposition. It occurs everywhere organic material sits — in the woods, in your refrigerator, under your fingernails and in compost piles. The first rule of composting: If decomposition is your goal, you can't mess up. It will happen. However, if hostile-odor free, relatively quick decomposition is your aim, you can help it along.

Your compost needs three things: air, water, and a correct carbon-to-nitrogen ratio.

Let's start with air. If you've ever smelled grass clippings stored in a sealed garbage can or garbage bag for a week, the reason the stuff reeks is because it's breaking down without oxygen. The microbes that break down compost work either anaerobically (without air) or aerobically (with air). The putrid grass clippings have made themselves home to the anaerobic microbes since air can't circulate around the material. These anaerobic microbes produce eye-watering gasses as they work their way through their

compost banquet, and to foster pleasant relationships with neighbors you'd best avoid making anaerobes feel at home in your compost. So, let it breathe.

When you build your compost pile start with some loose brushy stuff on the bottom, to let some air creep up through the pile. Use open material to hold in the sides — we use scavenged pallets. (The wooden supports heavy materials rest on when they're delivered to businesses, pallets measure about three feet by three feet and are easy to get from local grocery stores, plumbing supply stores, and the Missoulian.) As you build up the pile, add occasional layers of compostable material with lightweight bulk, like straw and hay.

Another trick: place a couple of old five-foot-long two by fours, three-inch or so diameter pvc pipes, or other , similar thickness, nontoxic materials vertically in the pile and layer the compostables around them. When you have the pile at the desired size, yank the boards or pipes out and you'll have air passages through the material.

Like most of us, microbes wither away without water and drown when submerged. You need to give them some water, but not too much. The penalty for allowing your pile to dry out is minor — the material will just sit there. However, allowing your pile to become too wet will cost you more — too much water means too little air, and we've already talked about what that means. You'll have an extended family of anaerobes moving in and your pile will start belching out the putrid gasses.

Keep your compost pile the consistency of a wrung-out sponge, moist, but not sopping. As you build your pile, layer dry and wet ingredients (for example, dry leaves and kitchen scraps, or grass clippings and straw). Most green, fresh material appears solid. But like ourselves, which we proudly think consists of muscle, sinew, skin and bone, green material contains a great deal of water. Anyway, the green material, as it breaks down, releases the water it contains, helping build the moisture level in the bin. In the summer months, when evaporation is high, you may need to add water to your bin. If you're trying to break down soggy materials, you may have to add extra dry stuff. Just keep an eye on it. No, keep a hand in it, and make sure it stays at the wet-sponge consistency.

As the final requirement to get your pile to break down at a decent rate, you need a good carbon-to-nitrogen ratio. Simply stated you need to balance the amount of carbon in your pile with the amount of nitrogen. These two elements are the primary foods of the microbes, and they need about thirty parts of carbon to one part nitrogen. Don't panic — forget the home chemistry kit and organic chemistry text. Instead, check Table 1 to get a rough idea of what you're putting in, and let your compost tell you when you have it right. Too little nitrogen, and your bin won't heat up or break down (check the moisture content first — it won't work if it's too dry either). Too much nitrogen and it will smell of ammonia, as the microbes spew out the excess nitrogen.

### Carbon-to-Nitrogen Ratios of Common Compostables

Material	Carbon-to-Nitrogen Ratio
Leaves (freshly fallen)	25:1
Leaves (dried out over winter)	50:1
Grass clippings	25:1
Legumes (peas, beans, alfalfa, etc.)	15:1
Manure	15:1
Manure with bedding	23:1
Kitchen scraps	25:1
Straw	50:1
Wood chips (without bark)	400:1

### What to Toss In, and What to Toss Out

We add what organic material we get to our bins. We don't stick to a strict recipe but instead toss in what we have available. When we get around to it we bring in a pickup truck load of manure, but often we compost without it, and we often mix in a bale of old straw or hay when we can scrounge one. We use plenty of kitchen scraps, coffee grounds, grass clippings, leaves, pine needles, dead plants and weeds (the seeds can go through the compost and sprout later if it doesn't heat up enough, so watch you don't put your nemesis weeds in if they're seeding).

Make sure you add only organic materials to your compost bin. Add nothing non-biodegradable or, guess what, it won't biodegrade. So no metal or plastic. Also, leave out rubber (yes, it's an organic material, but it won't break down) and colored paper (we leave out

all but unbleached paper, because we don't want the inks, dyes, and bleaching residues in our garden).

Watch out for roses and raspberries. The microbes eat the stalks away from the thorns and leave the stickers to get you when you handle the finished compost. Diseased plants have the potential to spread their disease through the finished compost, so compost these plants separately and take care where you use this compost, or burn the plants. We leave out meat, cheese, and all fats. These attract pests and give the microbes, who seem to prefer to stay vegetarian, problems with breaking them down.

Leave out pet litter from carnivorous animals, especially dogs and cats — these can spread diseases to you and others. And watch out for pesticides that can come through in manure, grass clippings and other vegetable matter. Some of these chemicals will continue to kill throughout the composting process, and may even remain active in the finished compost. Tordon, a widely used herbicide, can kill your tomatoes even after it has traveled through a cow fed on sprayed hay, and the contaminated manure has been through your compost bin and spread on your garden.

Tree prunings and other twigs and sticks take their time composting. The bark breaks down, but the woody material can take several trips through the pile to compost. If you dislike sorting out partially broken down sticks, chip them before adding them to your pile, or make a separate pile you can leave to break down over a long period of time.

Last, don't waste your money on compost activators and lime. Activators, concentrated microbes to populate your pile, are

unnecessary — the critters are already present in the air and on your organic material in sufficient numbers to get your bin going.

Remember, decomposition is going on all around anyway; you're just trying to manage it differently with your pile. And lime, meant to adjust the pH of the bin, provides nothing essential to the compost.

### Bins, Bags or Sheets— Find a Form to Fit the Function

Now that you know how to keep a pile working, how about building it? Well, it depends on which type of composting you want to do: sheet, trench, can, bag, fast pile, slow pile, biodynamic, U.C. Ogden 3-pile, Indore, or none of the above. Actually, all you have to do is remember rule number one: If decomposition is your goal, you can't mess up. Forget the complicated recipes and labor-intensive techniques. They work, but unless you want to marry your compost bin, let the microbes do the work and spend your time growing your vegetables. Any technique that allows for a good mix of water, air, carbon and nitrogen in a workable ratio, and hungry microbes, will do fine.

The compost bin is the method most people use to compost. A few more options work well here in Missoula, but don't feel limited by these. Feel free to adapt and create, doing what works best for you and your garden.

The pallet bin: We've made our compost bins from two materials, wooden pallets and rebar (the iron bars used for reinforcing concrete, available at building supply stores and at Pacific Recycling). We salvage our pallets and buy our rebar when we can't find it used. To build the bin:

- Pound two, four-foot pieces of rebar at least a foot into the ground and slide a pallet upright onto the rebar, so it stands up like a wall.
- Butt two more pallets up to the first one at ninety degree angles, forming what looks like a child's play fort.
- Slide these two pallets over rebar also.
- Lean a fourth pallet against the front of the bin, and you have it.

The pallets have large air gaps between the pieces of wood, allowing for plenty of air circulation, the wood lasts for four or five years before disintegrating, and the whole assembly is just the right size to keep a compost pile large enough to maintain its temperature during cold spells and small enough so the pile doesn't compress itself and go anaerobic.

This method gives us one more advantage. When you add a second (or third, fourth, fifth, sixth and seventh, as we have) pallet arrangement to the side of the first, with the two bins sharing one side, when it comes time to turn the pile, all you have to do is pull a pallet up from its rebar supports, and you can fork the decomposing material into the next bin without having to lift it out.

### PALLET BIN

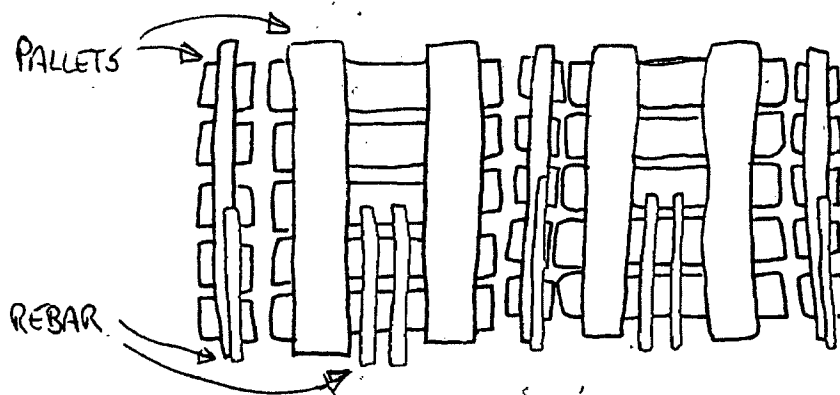



To build the pile itself, start with some brushy stuff to allow for ventilation under the pile, then start layering whatever you have to compost, keeping in mind the dry and wet potential problems and the carbon-to-nitrogen ratio. Keep the layers only a couple of inches thick, or mix the material before adding it. Watch out for too many leaves — they tend to mat down and prevent water from moving down through the pile, making the layers below dry out. Mats of leaves can also prevent air from flowing through, leading to the appearance of the dreaded anaerobes. Mix your leaves with other materials as you layer them in, or shred them before adding them.

Pile the material about three feet high, check the moisture and add water if necessary, then let it sit. After a day it will start to heat up. After three, the microbes will have it hot. You can check the center of the pile, where the microbial activity is at its most frantic, by inserting a long thermometer or by jabbing in a metal pipe and allowing it to heat up. If the pipe isn't blocked up, steam will soon come out the end protruding from the pile, and when you remove it, the end that invaded the thermophiles' domain will feel downright hot.

Turn the pile when it starts to cool down, in the summer after two weeks or so, and in the winter after a month. When you turn it, make sure you place the undecomposed material on the outside of the first bin on the inside of the second pile. This makes sure the microbes can get at the whole mess of material you've provided them, and you end up with completely composted organic matter.

After another three weeks in summer or another six in winter, your compost will be done and ready to spread on your garden. Sieve

it if you need to using a half-inch or so wire mesh, then get it in the garden. Use it now and use it lavishly. Unless you smother your plants, your garden can't get too much. Dig it in before planting, mulch with it, dig it in after clearing your beds, and pile it around your dormant perennials in the fall. Put a few inches on your lawn in the fall, too, to give it some nutrients for spring.

Here's a quick checklist of the process:

- Put down brushy stuff
- Layer compostables
- Check the moisture
- Let it compost, checking the temperature now and again
- Turn it when it's cool
- Let it finish composting
- Use it in your garden

Sheet composting works well on large areas with easily composted material, such as manure and grass clippings. With this method, you just spread the stuff on a field and let it sit. A few weeks before you're ready to plant, till it under and that's it.

We use this method on our community gardens, spreading leaves, coffee grounds, grass clippings and manure, then tilling them under. Within a few weeks of typical spring weather, the material has broken down enough for us to plant.

Trench composting provides you with another method of adding the material directly to your garden. Trenching gives you the advantage over sheet composting of getting the stuff underground

and out of sight and smell, but it takes more work. You need to first dig a trench through your garden about two feet deep, then dump in the compostables. Mound it over with soil, and let it go for a few months, making certain it gets enough water (water it as you would garden plants, getting the water to soak down to the compost).

We've trenched compost over winter, and have had good luck getting it to break down by spring. Two warnings, though: Dogs will untrench the material as it ripens if you don't bury it deeply enough, and onions often decide to grow rather than compost — come spring you may have a bed sprouting onions where you thought parsnips would go well.

Can and bag composting give you an opportunity to compost anaerobically and keep the odors sealed up. With this relatively effort-free method, you just mix the material together in a plastic bag or garbage can, seal it up and let it sit in the sun for at least six weeks. This method will punish you if you sneak a sniff before it's done. But when it's finished, it's fine-smelling, nutrient-rich compost.

### We Have Worms and You Can Too.

If you're living in apartments or have limited space or enthusiasm for backyard composting you can still turn your kitchen scraps into plant food. With worm-box composting you allow thousands of red wigglers, housed in a box in your home, to consume your compostables. They break down scraps in less time and space than traditional composting methods but take a little more care.

Worm-box composting is simple. You find or build a suitable container; provide some straw, shredded newspaper or leaves for bedding material; and add your kitchen scraps along with a writhing mass of composting worms. The worms live in the bedding material and rapidly plow through the kitchen scraps, leaving a rich fertilizer called worm castings.

You need only provide an adequate-size container, keep the bedding material moist but not wet, provide enough worms to eat your scraps and enough scraps to feed your worms, and keep the temperature of the box reasonable for the squirmers inside.

You can make a container out of anything that won't fall apart with use and won't poison your worms. We use boxes we've built ourselves out of exterior grade plywood and scrap lumber, costing us about \$40.00 to make. Others we know have used plastic bins, styrofoam coolers, and even garbage cans. The container need only be large enough, about six cubic feet of volume per person producing compostables. (You can vary this according to diet — vegaphiles produce more, vegaphobes less). For one person, then, a box one foot deep, two feet wide and three feet long will suffice. Double the volume for two people, and quadruple it for four. You get the idea. The designs we've used are in figure 1. Worms like feeding on the surface, so keep the container comparatively shallow.

One caveat: worms breath air, just as we do, so make sure your container will provide plenty. Avoid tight-fitting lids, and if you use a material that doesn't breath, including plastic and metal, cut vent holes. Consider lining the inside of containers with corrugated cardboard, which will please the worm in two ways: they will get

some air from the air spaces the cardboard will provide, and they will have additional organic material to snack on.

Once you have your container ready, add the bedding material. We've tried shredded newspaper, straw and hay, and leaves. Others use partially composted manure or shredded cardboard. You can use anything that provides the worms a moist space to live, has enough fluff to allow air to circulate, and that the worms can eventually eat and break down. Straw and hay remain our favorite because they're easy to get, break down easily and provide for plenty of air circulation. Shredded newspaper works fine, too, although I worry about the petroleum derivatives in the inks. Leaves have been my least favorite because they tend to mat down, decreasing ventilation and trapping water.

The bedding material needs to be moist, but not wet, about the consistency of a wrung-out sponge. You'll need to check the moisture of your box every couple of days to make sure it stays sponge-like. Bins can get too wet, drowning the worms, and wooden boxes in particular tend to dry out. We introduced a local kindergarten class to the idea of composting and wormboxes last year, and one young student volunteered that she had placed a couple of worms in her mailbox during the summer and they turned to wood. Don't let this happen to your wrigglers.

As for the worms, you'll need about a thousand, or one pound, to start a two-person bin. The worms reproduce like mad, though, so don't worry about having to few. Just keep a watch on the food supply for a few weeks, making sure it doesn't rot before the worms

get to it, and soon you'll have enough to consume everything you'll want to give them.

These worms you'll be using aren't earthworms, though. These are composting worms, *Aesinia foetida*, also called manure worms, red wigglers and redworms. They live on rather fresh organic matter, material that has yet to break down, as opposed to the earthworms in your garden who eat decomposed organic matter. You can find them in compost bins and manure piles, and can tell them from earthworms by their color — red — and their frantic activity. They wriggle like grunge fans in a mosh pit.

You can get a supply from a friend with a wormbox (once you have yours started, you'll soon have plenty to split off for someone else), from a mail order classified in the back of a fishing magazine (these are the worms use for bait, but don't confuse them with the fat-bodied nightcrawlers, which won't work at all in your bin), or from a local shop or person selling worms for bait.

Now the worm chow. Worms eat anything organic, with a few exceptions. We add no meat to our bins, although I know of people who do. Worms like it, but so do dogs, mice and rats, which all have no place in a worm bin. Oils and fats give the worms a hard time, and when they have a hard time eating something, it starts to rot. You'll enjoy your bin more if you avoid letting this happen. Likewise, avoid pet litter. Cat scat, in particular, can spread a couple of dangerous diseases by releasing the pathogens to the air. Moderate citrus — worms pick at the rinds, taking their time putting them down. Balance orange and grapefruit rinds with other materials, and chop them up some to give the worms an easier time attacking them.

Everything else, as long as it has food value for the worms, disappears quickly. Worms are fond of egg shells, and by all means, give them coffee grounds. Worms love a caffeine buzz, and will attack a pile of coffee grounds like there's no tomorrow.

Feed them as much as they'll consume or as much as you have to feed them, whichever comes first. Keep an eye on the bin — if the food is piling up without getting eaten, cut the rations for a few days until the worms are able to put it all down. (Or feed them more coffee.) When, after a few weeks, new additions to the worm population start popping out of their little cocoons, you'll be able to add more food. Don't worry about the population exploding beyond the box, raiding the fridge and harrasing the cat — the worms will regulate their population by how much food is available.

Add the food in piles, with plenty of bedding material underneath it, and a little on top. Keep the food together enough so the worms will have a nice feeding site, but don't let it get so packed down air can't get into the pile. And try not to allow the bedding material to get too packed down, for the same reason.

After a few weeks, you'll begin to see the rich, brown, sweet-smelling casting build up in your bin. These worm castings make extraordinary fertilizer. Castings contain higher levels of nutrients than does compost, and our houseplants almost purr when we add a half-inch or so to the soil around them. Our garden, too, loves the addition of these nutrients.

We rotate where we add food to our bin to help us harvest the castings. We start adding food in a pile at one end of the bin then slowly work our way to the other end, taking a couple of weeks to go

from one end to the other. By the time we're at the second end so are the worms, having eaten their way from one end of the box to the other. The original end will have been eaten and be ready for harvesting.

You can harvest the castings by lifting them out and placing them in a big pile on a sheet of newspaper in a lit spot. Because these worms hate light, whatever worms you pull out with the castings will make a quick dive for the bottom of the castings pile. You can then lift off the top of the pile and remove it, allowing the worms to further wriggle their way down. Continue removing castings and encouraging the worms to dive down, and by the time you've reached the bottom part of the pile, the worms will be huddled together with the last of the castings. You can then drop the mass of worms back into the bin. Add more bedding material to the spot where you've harvested the castings, and you're done. We harvest every three weeks or so when our worms are going strong.

Keep the bin in a site where the worms will have a comfortable temperature to wriggle. They enjoy most temperatures from 55 - 75 degrees F., but can tolerate five or ten degrees higher or lower. Too hot and they'll suffer, and too low and they'll slow down considerably. Don't let them freeze, or they'll stop completely. Most bin owners keep them in a basement or heated garage, but I've known some who keep their box outside year-round, insulating it heavily in the winter and shading it in the summer. We keep ours in our kitchen, where it doubles as a bench for our kitchen table. Although dinner guests often act unsettled when told what they're sitting on, we have a convenient compost site and an handy seat.



We call these containers worm bins only because worms make up the most evident population of the container. Along with the worms come a variety of organisms that assist the worms in their work turning your scraps into fertilizer. Springtails, sow bugs, millipedes, white worms, and mites make up a few of the critters in the bins. These all help break down the scraps, and cause no problems in the bin or in your home. Centipedes sometimes move into bins, looking for a snack of their own. These predators will eat worms and other organisms, so you may want to remove them, although they probably can't eat enough to slow down your bin.

Other, less welcome, inhabitants of bins are the fruit flies. Their eggs come in on citrus skins, banana peels and other fruit, and they then start hatching out. These pesky little gnat-sized flies are harmless, eating only fruit, but periodically they become a nuisance when they leave the bin and dive bomb our breakfast juice. They seem to inhabit worm bins as readily as worms, making them, as far as we've been able to tell, impossible to eradicate. A couple times a year, their population booms and you'll start noticing them in the area you have the box. You can trap them with open glasses of vinegar or beer, which they fly into and drown, or by hanging sticky strips of yellow fabric or paper smeared with a sticky sugar-containing substance, such as honey. Fruit flies are the only reason we sometimes bemoan our choice of using our bin as a bench in our kitchen — otherwise we'd have a perfect composting system in a perfect place.

Don't worry about offending yourself and your neighbors.  
Worry instead about your garden and lawn. You can take better care  
of your plants by giving them your own, home-rotted compost, and  
keep your and your neighbor's nose happy, too.

DO YOURSELF A FAVA  
TRY  
GARDENING IN MISSOULA

Here you are, living in the Garden City. You've watched your neighbors haul in club-sized zucchini from their yards, and you've talked yourself out of snitching a juicy red tomato. You're green with envy over their garden.

You make your pilgrimage to the farmer's market every Saturday morning, but it's not the same. You want to pull your own carrots, clip your own greens and dig your own spuds.

Me, too. Summers wouldn't cut it without a garden. But how do you garden in a city? How do you find space if you rent an apartment? How do you grow your own vegetables when Missoula summers have only three months between pepper-slaying frosts? And what do you grow?

Learning to garden takes gardening. You need to get your hands dirty. But fret not, even first-time gardeners get plenty of food from their garden, and even life-long gardeners lose their cabbage crop now and again.

We've fouled up a few crops of our own here at the MUD project, but we've learned from and enjoyed the effort. For Missoula-area gardeners, especially those gardening here for the first time, I have some recommendations that will short cut you past some of the mistakes we've made. I'll fill you in on Missoula's community gardens, give you some ideas of where to garden at your home, give a description of a M.U.D.-project designed and built wheelchair-

accessible garden bed, suggest how to choose seeds and container plants, toss in some suggestions of close-to-foolproof crops, and give some tricks to gardening with Missoula's fickle weather.

### Picking a Plot

Community Gardens: If you need garden space, head for the community gardens. You'll get a plot and access to water, and best of all, neighboring gardeners from whom to learn. At the Northside Community Gardens we provide compost bins, mulch materials and manure, and seeds for low-income gardeners. We also loan out sprinklers and tools, and we're available for help and advice, aided by a decent library of gardening books.

We charge \$10.00 for the gardening season and offer a work-trade in lieu of cash. Plots run out quickly, though. We have only thirty-two spaces, of which we reserve several for growing food for the Food Bank and Poverello Center, for Head Start school classes, and a few for other educational programs.

We assign plots first come, first served, giving priority to Northsiders without home garden space. We require everyone who wants a plot to show up for our season-opening work party, where we divide up the gardens into plots, make paths, set up the compost bins and eat large amounts of donated bakery goods. Call us at 721-7513 to find out donut flavors and to get more information on the gardens.

The university also has community gardens near the University Golf Course at the corner of South Ave. and Higgins Ave. ASUM (Associated Students of the University of Montana) runs the 48-plot

gardens, charging \$25.00 for students and \$30.00 for non-students. Call ASUM at 243-2451 for more details.

Unfortunately, Missoula lacks other formal community garden space. With enough vocal interest, perhaps the city and county will do what other similar sized cities do and integrate community gardens in with parks, giving Missoulaans more of a chance to live up to the Garden City designation.

Home Gardens: If you want to garden at home, you'll need to find a space for your veggies. Look for a sunny location. Trees can shade your garden, and some, especially shallow-rooted varieties, will out-compete vegetables for nutrients and water.

Our Siberian elm has made for a particularly poor garden tree. The bed nearest the tree dries out as quickly as a worm in a mailbox, and we've had pitiful luck with vegetables grown near it. I've spent hours digging around the garden bed and cutting out elm roots that go after the water and nutrients, to little avail. We suggest gardening away from these pests.

I'm all for ripping out lawns and replacing them with gardens. If you have one to rip out, go ahead. Water it well, then flop the sod green side down. Water it occasionally, chop it up with a spade after several weeks, and turn over the straggler patches of grass that insist on trying again. In a few months, with little effort, you'll have a bed for vegetables, complete with its own compost — the old grass. We've successfully done in a good patch of lawn on our property this way, although we've replaced it with native plants instead of vegetables

We've also tried smothering grass with black plastic, which we've scrounged from construction sites. Smothering works to kill the grass after a few weeks of summer sun, but it also kills beneficial organisms in the soil, leaving it worse off in the long run. Earthworms especially suffer from this technique.

When you have a site in mind, check the soil. You want to grow your veggies in ground that wasn't previously used as a driveway, sandbox or dump. With enough compost you can work wonders with awful soil, but you might as well start with soil that has plants growing in it. If your soil grows healthy weeds, it can grow healthy vegetables (but rarely both together). The trick to keeping down weeds in weed-seed infested soil is to mulch it heavily. Most weeds need sunlight to germinate. Mulching with straw, grass clippings or other materials will block the light the weed seeds need and keep them from sprouting.

You can find good soil here in the Missoula Valley. Sadly, the site of the valley's best soil, silt-loam over six feet deep and fertile enough to grow pumpkins the size of elephants, sits under the future Walmart. Instead of pumpkins it will grow discount consumer goods. I'll curse their choice of a site to build every time I uproot another rock from our community gardens and heave it toward our ever-growing pile of stones.

If you, too, have the more typical cobbled soil of the valley, you can still grow those pumpkins. The key is to enrich the soil. Add compost or manure. Pile it on and work it in. We put on a couple of inches before we plant and again after we clear our garden beds in the fall.

We make our own compost, and we've found manure easy to get within twenty miles or so. Keep your ears (or nose) open for anyone raising goat, sheep, llamas or rabbits. These manures all work well in gardens. We've found cow and horse manure less valuable because these staples of the settled West have less efficient stomachs and pass through weed seeds, which you need less of in your garden. Their compost is also hotter than goat, sheep, llama and rabbit manure, and needs to age for several months before you use it or it will burn your plants.

Watch out for pesticide-laden manure (this goes for grass clippings you use for mulch as well). Tordon, a commonly used and potent broadleaf herbicide, can move from an animal's feed into its manure, through the composting process, and do in your tomatoes. Ask your manure source if the animals ate sprayed hay.

Don't go overboard on manure, unless you compost it first. Too much will encourage your plants to put too much effort into producing greenery, and you'll get tall, spindly plants with pitiful root systems. If you're eating the roots, as with carrots, you'll find little to munch on.

We've also found a few problems with bedding material, especially hay, in the manure we've brought in. When we've spread this stuff over our garden, we've regretted it. Weeds come in with the hay, and we've found nothing better at choking out our plants than the cakes that form over the winter when manure and bedding material mold themselves together into a plaster. We lost an entire garlic crop to this oversight. Compost such manure before using it.

The composting process will destroy most weed seeds as well as breaking the mix down.

Wheelchair-Accessible Garden Beds: If you're in a wheelchair, you can still garden either at home or at the Northside Community Gardens. We've built a half-dozen raised beds accessible to wheelchairs; at our community gardens, at people's homes and at Eagle Watch Estates, an apartment complex for people with mobility impairments.

The beds are about thirty inches tall and twelve feet long. The sides angle in from top to bottom, making room for gardeners to fit their knees, feet and wheelchair footrests under the beds so they can more easily reach the plants and soil. The beds are thin enough so a gardener can reach at least half-way across from either side.

We build the bins out of almost entirely salvaged materials. Mountain Press Publishers have provided us with wooden skids, solid pallets on which they receive their books, which we knock apart and reassemble for the sides. We line the inside with plastic scavenged from Conlin's Furniture — they receive all their mattresses, sofas and other furniture wrapped in heavy-gauge plastic— which keeps the soil from contacting and rotting the wood, and helps hold in moisture.

If you're interested in gardening one of our beds, call us.

### Successful Seeds and Healthy Starts

Select seeds with the same care you select a site. Ten for a buck seed packets will give you inferior veggies. The seed companies that



can afford to sell their seeds at such prices grow their seeds where the plants grow best, in climates with plenty of precipitation and long summers. They grow varieties adapted to these climates, not to the peculiar conditions of western Montana. If you want vegetable varieties that grow well in our short, cool, dry summers, buy your seeds from companies that grow and market northern-climate-adapted varieties, including Garden City Seeds in Hamilton.

Some crops, even those grown from climate-adapted seed, can't go from seed to fruit in one of our short summers. These warm-weather crops, including tomatoes, peppers and eggplants, all need more time between frosts than Missoula gets. Nevertheless, you can get a harvest from these plants by planting starts, or seedlings. You can either buy seedlings or start the plants indoors before the season and plant them out after the last frost of the spring (which usually occurs two nights after you've transplanted your frost-sensitive plants). The Missoula Valley is usually safe from frost by the first of June.

If you choose to buy starts, again invest in varieties grown for this climate. Warm-weather plants need more time than our climate gives them, but some varieties still do better than others. Our cool nights slow down warm-weather plants here. Tomatoes, peppers and eggplants either won't set fruit or the fruit stays tiny and won't ripen. But climate-adapted varieties overcome these conditions and give you a crop — they're bred to thrive on cool nights.

Both Freddy's Feed and Read, the Good Food Store and the farmer's market offer good quality seedlings each spring grown by local growers from carefully selected seed.

Lest you make a run for the discount plant greenhouse-warehouse, organically grown starts outperform chemically fertilized varieties. The blasts of chemical fertilizer given many mass-produced seedlings to get them large and green seems to prevent them from taking off once you transplant them. You'll spend more but get better vegetables and healthier plants when you buy local, organically grown starts grown from climate-adapted seed. Ask the grower about the varieties and conditions used.

### Crops That Thrive

If you've never gardened, or if you have gardened and harvested nothing but weeds and bug-ridden embarrassingly scrawny veggies, we've had a few plant varieties grow well enough to threaten a take-over of our garden.

So if you're worried about the hue of your thumb — if you think it may be some color other than green — or if you're worried about how much time you have to spend on your garden, here are the MUD project's closest-to-foolproof garden recommendations:

#### Greens

*Red, Green and Yellow Orach:* When gold miners moved into the mountains of Montana they brought with them seeds of vegetables they thought would make it in the tough climate. Orach, pronounced oar'-ack, was one of these varieties, and they were right about its ability to survive the tough weather. Garden City Seeds markets a variety taken from orach plants found growing near the ghost town of Bannock.

The plant can grow over six feet tall and has spade-shaped leaves up to six inches long and nearly as wide. You can eat the young shoots and greens raw in salads or cooked in any way you'd cook spinach. It has a mild flavor, more mild than spinach, with a slightly salty taste.

My favorite way to prepare orach is to steam the largest leaves for a minute or so and sprinkle a little lemon juice and soy sauce or tamari over them. I then eat them and wonder why anyone plants spinach when orach produces more greens and stays edible in the garden for so much longer — spinach goes to seed early in the spring and becomes virtually inedible while orach goes to seed later and stays tasty even after starting to bolt.

Orach comes up as soon as the snow melts, if you plant it in the fall. If you plant in the spring, you can put it in as soon as you can get into your garden without drowning your shoes in muck. The seed likes to be near the surface of the soil, and seems to germinate better where it seeds itself in our garden than where we seed it.

It seeds itself so well we needed to plant it only once, leaving some plants to go to seed every year (although we insist on trying to get it to grow where we predetermine it should grow, and plant it anyway). It pops up in unexpected places in our garden each spring, and when it doesn't interfere with other plants we want, we leave it.

The red, yellow and green varieties taste and grow similarly, but have different colored leaves. Red orach especially astounds guests when you serve it in a salad. The color of a good red wine, it has a sheen that catches the light and impresses the most snooty of food snobs.

*Kale:* Here's a tough-as-nails but tender-as-toast green. I suggest trying blue Scotch-curl and conserva, two particularly hardy varieties.

Related to cabbage, cauliflower, broccoli and Brussels sprouts, kale has ruffled edible leaves that grow up to a foot long. These two varieties of kale are virtually indestructible when it comes to weather. I just checked our garden, and after nearly a week of cold with temperatures down to minus 10 degrees F., the kale is still alive and green. As it warms up to 30 degrees F. or so new leaves start coming out, and away it goes.

As impressive as its ability to withstand cold, is kale's resistance to insect attacks. Some summers our cabbage gets riddled with cabbage worms, turning it into coleslaw on the stalk. But bugs barely touch the kale. The worms leave it for us, indicating their poor taste in vegetables, because kale has wonderfully rich flavor. It tastes faintly of cabbage, but rarely gets the metallic pungent flavor. Kale tastes especially good when other greens disappear from the garden after a hard frost. The starch in the leaves turns to sugar, and the leaves become as sweet as candycorn, but with flavor.

When the leaves are young, small and tender, they work well in salads. As they age and get larger, they're better cooked. I like them steamed for a minute or two, spiced up with some sautéed garlic, and put over rice. Kale also gives you a healthy dose of nutrients, including plenty of Vitamin C and iron.

*Curly Cress:* If you have problems planting seeds too close together and getting masses of stunted plants, here's a salad green that tolerates such treatment. As an added bonus, with cooperative weather you can harvest ten short days after planting.

Curly cress, also called pepper grass, tastes like a tiny bit of good mustard wrapped in a crisp lettuce leaf. It looks almost like a curled parsley plant, but with smaller leaves.

Let curly cress grow two to four inches tall, then clip it with scissors or your fingers and add it to salads or sandwiches. If you leave some greenery when you cut it, it will come back for more cuttings (this harvest method is known as the cut-and-come-again technique, and also works well for leaf lettuce).

*Mizuna:* Another of the exotic greens to impress food-snob friends, mizuna gives you a chance to grow a green with taste galore that takes minimal care. Mizuna has lettuce beat leaves down for flavor and appearance. It has serrated leaves as orderly as a saw blade, and a nut-like flavor. Again, you can sow it thick and use scissors to harvest it. It, too, comes back after a cutting if you leave the tiny new leaves at the center of the plant.

*French Sorrel:* If you like the slightly sour bite of a good glass of fresh lemonade on a hot and thirsty summer day, you'll love the taste of French sorrel. This green comes up early, stays around all summer, and since it's a perennial comes back next year, too. It forms twelve-inch diameter clumps of long upright leaves, which you can put into salads or soup.

The only secret to keeping sorrel going is to cut down the flowering stalks during the summer to encourage it to produce leaves instead of seeds.

You can get sorrel from cuttings or from seed. Both ways work well, although cuttings will get it established in your garden more quickly. Ask someone with a plant to dig out part of their plant, and split it with you, or find it at the farmer's market. Garden City Seeds has the seed, if you prefer to try this approach.

### Root crops

*Potatoes:* Spuds give you a tasty and bountiful crop. The Bitterroot Valley was once a hotbed of potato production, and we've found spuds thrive in Missoula, too. Although we sometimes have a tough time separating the potatoes from the rocks when we dig them, we've had phenomenal luck raising plentiful, good-tasting, pixie-football-sized taters. I suggest caribe, sangre and yellow Finn varieties for flavor and hardiness.

Caribe has purple skin and dry flesh, great for baking. Digging potatoes is fun enough, but add the pleasure of finding purple taters, and you'll have a new favorite fall tradition.

Sangre spuds, with red skin and creamy flesh, grow large and near the surface, making them easy to dig. We've pulled out Sangres nearly big enough to feed a family of four and require a wheelbarrow to move them. They make good early potatoes, too, if you dig them earlier in the summer when they're smaller.

Yellow Finns, too, grow large and plentifully. They also have creamy flesh, with a yellow hue to it. Yellow Finns are as fun to dig

as summer clouds are to watch — just as you can search clouds for intriguing forms, you can pull up the spuds and see animals in their odd shapes.

Just as with other seeds, invest in good seed potatoes. A seed potato is simply a small spud. Once planted, the new shoots emerge from the eyes of the tuber, head up through the soil, and form the plant. New tubers form on the roots of the new plant. Reputable seed companies offer quality seed potatoes, free from disease and ready to grow. Garden City Seeds offers all three varieties, plus several others.

Old Missoula gardeners insist the time to plant potatoes is either on Good Friday or St. Patrick's Day, depending on their preferred spring holiday. Put them in sometime near these dates, and you'll do fine. We plant ours when we feel like it in the early spring, in trenches four to six inches deep, covering the seed potatoes with a little dirt and then a few inches of straw to start our mulching.

Mulching our spuds has helped them immensely — we continue to bury our taters with straw or hay as they grow. When the plants work their way up through the mulch we add more, until we have at least ten inches piled over the whole bed. The mulch holds the moisture in so the bed dries out less quickly, and it shades the soil so it stays cooler. Spuds appreciate the moist, cool soil, and respond vigorously. Developing tubers also turn green when exposed to sunlight and become inedible. Mulching saves the close-to-the-surface taters from greening.

*Garlic:* Even if you're not a garlic eater, it belongs in your garden. Not only can you munch on a clove or two and breathe on annoying house guests, but it helps keep insect pests from your garden.

Garlic also makes for attractive gifts, if you're willing to part with it. Think of how thankful your friends and family will be when you braid up a half-dozen garlic heads and give them as presents.

Garlic grows from cloves, so if you find good, locally grown eating garlic, you'll have good planting garlic. Garden City Seeds sells several good varieties.

Garlic grows best when planted in the fall, from September until the soil freezes up. To plant it pull apart the bulbs into individual cloves. Leave the skin on. Select the largest, undamaged cloves, and set the smaller ones aside for eating. Plant the cloves singly about six inches apart and two inches deep, and cover the whole area with six inches of straw. The straw will help insulate the garlic over the winter protecting it from the worst of the cold, and come spring it will work as a mulch to hold down weeds and keep in soil moisture. The garlic will come through the straw when it sprouts in the spring.

Harvest the garlic around mid-July, when the leaves start turning yellow. Wait until four of five have yellowed about half-way down the stalk. After you've dug them, let the bulbs dry for a few days in a shady site, clean them gently by brushing off the easily removed dirt by hand.

### Other Veggies



*Fava Beans:* Every few years Missoula gardeners wake up on a chilly June morning to find their beans zapped by an unexpected freeze. Every few years Missoula gardeners wake up on a chilly August morning to find their beans zapped by another unexpected freeze. Regularly, we get hit with a frost when we don't expect it, which makes growing freeze-intolerant plants difficult. You can still get beans, though, even if it snows a foot on the first of July by planting fava beans.

These beans enjoy conditions that peas like, germinating in cool soil and growing vigorously in cool weather. You can plant them as soon as you can get into your garden, and the beans will be ready to pick by mid-July.

Fava beans grow into nearly four-foot-tall masses of beautiful glossy green leaves, with purple and white blossoms attractive enough to plant as ornamentals. The beans grow in up to eight-inch-long stout pods. You can pick the beans when the pods fill out (gently squeeze the bulges in the pod to see if the beans have ripened), then shell them out like lima beans. Or you can let them dry and use the shelled-out beans like any other dry bean.

Favas have a taste somewhere between a pea and a bean, with a full bean flavor but plenty of sweetness. We steam our green favas, adding garlic before eating them, or we add them to pasta sauce or soup. Our Italian neighbor, who calls them "favi," lets his beans dry on the plant. He shells them out and, following a recipe his mother brought over with her from Italy, soaks them until he can remove and discard the skin. He then grinds up the meat and adds it to red pasta sauce.

## Flowers

*Johnny-Jump-Ups*: These little violets jump up. One minute we're looking out at snow-covered beds, we then turn our backs, and when we turn back around our garden is covered with gold, deep blue and white flowers. We've even found them blooming under straw mulch in the middle of a cold February. And we never plant them.

*Johnny-Jump-Ups* usually grow low to the ground in dense clumps about six inches across. They bloom nearly all summer long, as long as they have enough water. The dime-sized blooms come in varying mixes and shades of blue, purple, yellow, gold and white. Adding to their attractiveness, they're edible, with a mild wintergreen flavor. We've found they spruce up a cake as well as any frosting, and they give salads a blast of color.

These flower also help us with our raised garden beds. We've piled the soil up into long, thin beds about two feet across. The raised beds allow plants to send their roots deeper into the concentrated topsoil, and since the beds sit up higher they warm up more quickly in the spring when the sun hits them, allowing us to plant them earlier in the year. One problem with raised beds is that soil collapses from the edges into the paths that surround them. Our volunteer *Johnny-Jump-Ups* solve this problem by allowing us to surround our raised beds with them, holding the soil together with a living edge.

*Sunflowers:* I'd betray myself if I didn't mention sunflowers. They, too, characterize our garden without our planting them. They spring up of their own accord in the late spring, and our yard glows golden come August.

We have a multiple-headed variety similar to the wild species. They grow about six feet tall with upwards of a half-dozen three-inch diameter blooms per plant. They range in color from nearly white to deep gold rimmed with crimson, and bloom for weeks on end.

The birds love them, too, swarming in and gorging themselves as soon as the seeds start to form. They also scatter the seeds around the yard for next year's crop, keeping spontaneity in our plantings.

### Climate-Induced Gardening Tips

*Mulch:* Mulching eases the difficulty of raising vegetables here like little else. By covering the soil around garden plants with a material that breaks down, including grass clippings, leaves, straw and coffee grounds, we've decreased our watering significantly as well as our weeding.

Tomatoes, peppers and eggplants appreciate greatly having the soil around them covered, as do potatoes. Mulching kale and other hardy greens gives them an even easier time making it through the cold snaps. And beans, corn and squash likewise benefit from added moisture and less weed competition.

Pick your mulch by what's available. Grass clippings, as long as they're unsprayed, are one of our favorites, as are coffee grounds. We get our grass clippings from St. Mary's Cemetery, right next to

our community gardens (lest you think we remove the clippings from our small lawn).

To get coffee grounds, we've placed fifty-gallon barrels behind several local caffeine joints, which they graciously fill with their dregs. We collect the barrels every couple of weeks, wrestling them home and dumping them on our garden beds, thereby increasing exponentially the metabolic activity of our earthworms. An inch of coffee grounds surrounding our beans this past year cut our watering by at least half and our weeding almost entirely. Grass clippings did the same for our tomatoes, peppers and eggplants.

Mulch your plants after they've emerged, keeping the material an inch or so away from the plants' stalks. Avoid mulching tender greens, including lettuce, or they will rot. Knock down weeds before mulching or they will pop up through the stuff, and remember that just as mulch keeps the moisture in the soil from evaporating as quickly, it keeps moisture from above from working its way down to the soil as quickly. You'll have to water less often, but more thoroughly.

*Soak your seeds:* Growing many frost-sensitive plants in the Missoula valley can be a crap shoot. Every few years, including the past two, we get an early fall freeze that nails squash, beans and corn before their fruit ripens. You can cover your plants with plastic, sheets, blankets or other material and hope for the best, and you can also extend the season the plants can grow by getting them to germinate earlier. Corn and beans especially benefit from soaking.

Warm-season crops need warm soil to germinate. Missoula gets its cool rainy season in May, June and early July, when these seeds need sunlight on the soil to warm it up enough for them to sprout. We force our seeds to germinate by soaking them in water for a day, then placing them on trays lined with moist cloth. We wrap the trays with plastic to hold in the moisture and let them sit inside where it's fairly warm for a couple of days. By then the seeds have begun to sprout, and we carefully plant them as we would unsoaked seeds, keeping the shoot pointing upwards through the soil. This allows us to plant earlier than we could otherwise, and it cuts the time of emergence of the plants by up to ten days.

A late spring freeze still endangers the seedlings, but covering them on nights when frost threatens will usually save them, and if you lose them, you can still soak and plant again.

Give gardening a try. You'll probably notice your neighbors longingly eyeing your orach and favas, wondering how they can get their hands on them. And as you remember your past garden envy, you'll probably find yourself giving them some.

## NON-TOXIC LAWN CARE

### MAKE THE GRASS GROW GREENER ON YOUR SIDE OF THE FENCE

When a house goes up in Missoula, and most anywhere else in the U.S., lawn goes around it. We accept lawn as landscape as we accept pavement for streets. But lawn makes for a difficult-to-care-for and energy-, water- and time-intensive yard.

Think of the climate of the Missoula Valley. Bunchgrass, not bluegrass, has adapted to our rainfall. If you want bluegrass, you're going to have to work for it. It needs Kentucky conditions — plenty of water and deep rich soil. And it may help if you talk to it in a nice slow drawl now and again.

Even with the odds stacked against Kentucky blue in Montana, we've found we can keep our lawn healthy and attractive without using artificial fertilizers and pesticides, and we've found organic lawns are healthier and ultimately easier to care for than Nitrogreen Chemlawns. We've chosen where to put our lawn, we enrich the soil with generous fall feedings of compost, we let clover grow in it, we let it grow longer but cut it evenly — leaving the clippings on, and we water infrequently but deeply.

#### I Know It's Just a Lawn, but Where Do We Put It?

Rather than as default landscaping, choose to plant lawns where they serve a purpose: perhaps sunbathing, picnicking, and croquet. For other areas consider plants that take less water and work and make formore interesting and attractive landscaping.

Landscape with native plants, which know how to live with our thirteen or so inches of precipitation and our capricious winter weather. The less you do for them the better they do. Try that philosophy on your lawn and see bluegrass become yellowgrass.

Even with my tirades against bluegrass we have lawn on our property. Am I a hypocrite? Well, not because of this. I want our lawn. It serves as a gathering place for us — we have a picnic table and places to sit, and we often eat there in the summer. We avoid the croquet, though — too close to the vegetables, which take poorly to whacks with wooden mallets.

### The Dirt on Soil

To start, healthy lawns need healthy soil, something rarely found on developed lots in this valley. To be resilient to drought and pests grass plants need deep roots that reach down to moist, even-temperature soil. Grass also needs soil with plenty of humus (decomposed organic matter) with its wide range of nutrients, water-retention ability and tilth (loose, workable structure).

If you've ever tried to dig a shovel more than six inches down into the soil in most parts of this valley, you've seen that round, polished rocks constitute a good portion of what lies under our feet. These stones and the rest of the rocky debris left by Lake Missoula and the rivers that have run through our valley give bluegrass little of what it needs for deep root systems. If glacial till were humus, we'd be in gardeners' paradise. But with topsoil at a premium, we need either to enrich our soil before planting grass or add organic matter to established lawns.

If you haven't yet seeded your lawn, check how much topsoil you have. Your grass needs at least eight inches, so add some before planting. Also, work in four to six inches of compost before seeding.

Most of us lack the luxury of being able to add top soil and compost to our soil before putting in a lawn. We have established lawns over pitifully thin soil and have difficulty keeping the grass thick and green. If you have such a lawn, you have a couple options: you can dig up the lawn and add topsoil and compost, or you can spend some time building the soil with the grass in place. If you're like me, you'll choose the latter. We add compost every fall (about two inches over the entire lawn), and we never remove the grass clippings when we mow — they add much-needed organic matter to the soil, mulch the grass plants, and contrary to what the lawn plugger companies want you to believe, play no part in thatch build up.

### Variety Is the Spice of Lawns

Lawns were first grown in a wet and fertile land much different from Missoula to do just what we enjoy lawns for. But they looked different. They had dozens of species of low-growing flowers and grasses, giving them a large amount of diversity and color. Only recently have we decided that lawns need to be monocultures of a single grass species. This idea is rough on your lawn, just as it is for any monocropped area. Pests zero in, and diseases run rampant. And we're stuck calling everything that isn't grass a weed, ferociously spraying it or yanking it out. Planted as a monoculture your lawn



needs more care than if it were a mix of species, and keeping it healthy is difficult.

If you set aside the worship of monoculture carpet, you can solve this problem. Add variety to your lawn. Use several varieties of grass seed — even small areas of lawn have different conditions, so one variety will do well where another won't, as in the shade of a tree. Add clover to your mix, and you'll have a self-fertilizing lawn. (The clover, in the legume family, fixes nitrogen from the air making it available to the grass with which it grows.) Or add low-growing flowers, perhaps daisies or chamomile, to your lawn. And look into drought-resistant, deep-rooted grass species rather than the standard Kentucky bluegrass. Seed companies have recently made available seed mixes with buffalo grass, many varieties of wheatgrass, wild rye, and several fescues, all deep-rooted grasses that will need less care and water than traditional bluegrass mixes.

Tom Cook, a researcher at Oregon State University, has produced a variety of seed mixes containing noninvasive, deep-rooted grasses mixed with legumes and flowers. Cook has selected varieties that grow well together, tolerate mowing, won't crowd each other out, and are drought tolerant, needing less than half the water of a conventional lawn. The flowers mixed in make for a striking lawn, which winds up looking more like a meadow than a typical sod patch. Cook's mixes are available from small, regional seed companies, including Garden City Seeds, Abundant Life, and Bountiful Gardens.

Seed Money

Seed is not the place to look for the blue-light special. Good quality seed carries a premium price. Consider, though, that you'll be watering less, weeding less and fretting less, and you can be more sure your grass will take when you use quality seed. In the long run you'll more than make up for the difference in price. Buy your seed from a reputable seed company that specializes in providing seed adapted to our climate. Find seed with the characteristics you want and pay the premium price — you'll save in the long run.

### Grass Crowns and Weed Seeds

So why all this talk about deep rooted? What is it that makes for a healthy grass plant? Let's look at the structure of the plant.

Grass differs from most other plants in that it grows from a crown rather than a meristem, or growth tip. For those who don't know a crown from a meristem in the ground, here's a diagram of a grass plant:

### Grass Plant vs. Weed Plant

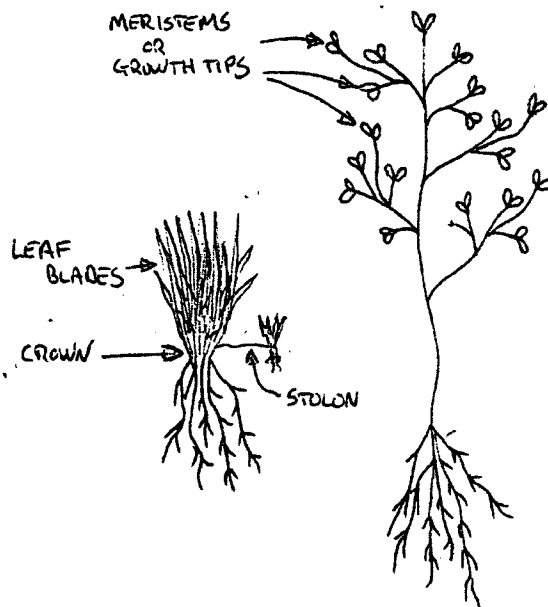

The grass plant sends up its leaf blades from the crown, while most plants grow from their tips. This means that when you chop grass off its growth area remains well beneath the cut. The weeds in the lawn when chopped along with the grass, however, lose their growth tip (the meristem) and have a significant burden put on them to replace it. Grasses have adapted to countless centuries of being grazed on by ungulates and others, making them able to thrive after having been cropped.

Grass plants are also able to cram themselves into areas they inhabit. A typical 1000-square-foot lawn, say 25 by 40 feet, has roughly 1,000,000 grass plants.

Deep roots help grass plants by giving them access to more water and nutrients. In the heat of summer and cold of winter, the deep roots also help the plants keep a more even temperature. Deeper soil stays cooler in the summer and warmer in the winter — it softens the temperature extremes because it lies under the insulation of the top layers of soil and plants.

Roots also serve as the food storage portion of grass plants. In winter, when the tops of the grass plants are dormant, the roots hold the nutrients necessary for the grass to shoot up in the spring. Deeper roots allow for more food storage and a healthier, more robust comeback by the lawn when winter ends.

Deep roots involve more than genetics — you can encourage standard varieties of grass to lengthen their roots, too, although the deep-rooted drought-resistant varieties will send their roots even

deeper. You can still make a Kentucky bluegrass lawn less water intensive by changing the way you water and cut it.

### Tall Blades and Even Cuts

Dredge up your memories of high school biology and sort through to find the part about photosynthesis. As you doubtlessly recall, photosynthesis is the process plants use to convert sunlight to food. The green color of the leaves of plants is chlorophyll, a chemical that plants manufacture to aid in trapping the energy of sunlight. The green in grass leaf blades serves this purpose, and these leaf blades give your grass its food. It makes sense that your grass wants its blades — it needs to feed itself. And to maintain a deep root structure, it needs plenty of food from its leaves.

I know I said grass thrives on cutting, but the cutting grass has learned to thrive on involved teeth chomping down on it irregularly, not metal blades whacking it off bi-weekly. I'm not encouraging you to dump your mower and graze your lawn, just change the way you mow and the frequency.

Let your lawn grow a longer than you're used to — keep it two to two and a half inches long. This length gives the grass enough blade area to photosynthesize to its crown's content, giving it enough energy to maintain its roots and fight off diseases and pests. The higher grass will also shade the soil, reducing evaporation and requiring you to water it less. Longer grass also grows slower. Short-cropped grass, frantically trying to get some leaf area back to produce food, will grow much more quickly, meaning you'll have to mow more often.

But that's not all. Taller grass shades out weeds, too. Most common garden weeds germinate when exposed to sunlight, and pop up in bare spots or closely cropped spots on your lawn. Longer grass keeps these weeds in their seeds.

Most mowers come with adjustable height settings, except for some push mowers. To raise the height of one of these push mowers, try wrapping a length of black plastic irrigation pipe, available at plumbing supply stores, around the tires, and screwing it in place over the tires with one and a half inch self-tapping wood screws, screwing through the plastic pipe and into the tire.

All right, let's deal with looks. A long-haired lawn doesn't mean a scraggly, unkempt lawn. Lawns look tidy when they're mowed evenly; they don't have to be mowed short. I always find a lush green lawn, with longer blades, more welcoming than a chopped off, spikey, yellow-green lawn.

Keeping your grass long is only part of mowing for health. Like a child at the barber's, grass also appreciates not having too much removed at one time. Try to take only one third or less off per cutting. To keep the lawn at two and a half inches, then, you need to cut it when it reaches around three and a half inches.

Keep your mower sharp, too. Dull blades bruise and yank, just as do dull scissors at the barbers. Your lawn will recover from a cutting that much more quickly if cut cleanly. Dry lawns cut more easily than wet ones. Wet grass tends to wrap itself around the mower blades and to flatten out on the ground, making it difficult to cut. Wait until your lawn dries before cutting it, and if it gets matted down, rake it up before cutting it.

One last item about mowing, perhaps the most important one: Leave the clippings on the lawn. Don't rake them and bag them. Every time you remove clippings from your lawn, you're removing the nutrients held in the blades of grass, meaning you'll eventually have to replace those nutrients with some sort of fertilizer to maintain the lawn's health. Leaving the clippings allows the nutrients to return to the soil.

Leaving clippings also helps mulch the grass plants. Mulch holds in moisture and helps moderate soil temperature, so your lawn will require less frequent waterings and your grass will have less chance of drying out, burning up, or freezing out.

Clippings provide nutrients for more than the grass plants. One pound of healthy soil contains about 900 billion organisms. The microbes in the soil surrounding the plants feast on the clippings, breaking them down so other helpful organisms such as earth worms can eat them, with the nutrients eventually making their way back to the grass plants.

If you're worried about the dreaded thatch building up in your lawn because you're leaving your clippings, rest easy. Thatch results from over-fertilization, which causes the grass plants to get a little excited with their stolon growth. Stolons are above-ground reproductive shoots that, with proper conditions, allow plants to clones themselves. If you've tried growing strawberry plants, you've seen the stolons, with a miniature strawberry plant at the end of each one, shooting out during the summer. The varieties of grass plants we use for lawns reproduce the same way, which allows them to fill in the gaps. When you dump on too much nitrogen, they react

by going stolon crazy, sending out these runners like Walmart sends out new outlets. After a while, the surface of the ground is a mat of stolons, choking the plants.

### Don't Feed the Lawns

So take it easy with the fertilizer — it often does more harm than good. In addition to thatch, over-fertilization with quick-release fertilizers can harm the soil structure, killing off microbes and other organisms that inhabit the soil. Microbes and other critters play a huge part in cycling nutrients and maintaining soil conditions that healthy plants need. Too much nitrogen can also encourage the grass to generate excessive leaf blade growth at the expense of roots, leading to weakened plants. Plus, if you leave your clippings, you leave the nutrients, making adding more unnecessary.

If you need to fertilize, use compost. Compost has the nutrients the plants need, but releases them slowly as the plants need them. It will aid the microbes and other organisms and will help build the soil for the long term. Add an inch or two in the fall, spreading it evenly over the whole yard.

Grass plants spend the spring converting the stored food in their roots into leaves, quickly forming a nice green lawn. They spend the summer taking it easy, trying to get through the hot weather they don't much like. Come fall and the cooler temperatures, they get active again, this time photosynthesizing as quickly as possible and storing the food back in their roots, preparing for winter dormancy and the spring's new growth. The time to fertilize, then, is in the fall, when the grass needs food to store. Fertilizing in the

spring and summer aids the weeds in the lawn as much as the grass — most lawn weeds come on in the early summer, just when the grass is starting to take it easy due to heat. Fertilizing then will give weeds a boost and your lawn a variety of plants you don't want.

### Long Drinks, Not Short Sips

Lawns need water, even the less water-intensive varieties. But lawns don't need as much water as most people give them. They waste water, money and the health of their lawns by watering too often and too shallow.

Your grass isn't stupid — if water is available near the surface, it will develop roots to get at the shallow water, sparing itself the effort of going deep to find it. In the long run the plants will suffer from their laziness, though. A dry hot spell will heat up the surface of the soil, drying it out and cooking the plants. Likewise, in the winter, the top of the soil experiences much more severe temperature swings, something your plants can also do without. Practice the tough love of lawn care — force your grass plants to send their roots down deep by watering deep. It's for their own good.

Rely on the soil and grass to tell you when to water. Since Missoula's weather doesn't operate on a schedule, watering effectively can't either. Allow the top inch or two of the soil to dry out before watering. Plunge a shovel down into your lawn and pry it back to see the soil layers. If the top few inches are dry, set a slow sprinkler on the lawn and let it go. Don't fret about the shovel in the lawn. Tamp the pried up area back together, and the grass will



quickly cover up any trace of your digging, and will probably appreciate the aeration.

Your grass, too, will tell you when it needs water. It turns a blueish color when under drought stress, the leaf blades curl up from the edges and footprints stay evident when you walk on it. When it starts to show these signs of thirst, give it a drink.

Water slowly so the water penetrates instead of pooling and running off. You need to add about two inches of water to penetrate the soil six to eight inches, the depth your grass' roots need to reach. Set a coffee can out on the lawn while you're sprinkling — when it has two inches of water in it, you've added two inches to the lawn. If you want to check to see how deeply the water has penetrated, once again, use your shovel. Pry back the grass and have a look.

In a typical Missoula spring you shouldn't have to water. Our rainy period usually runs until nearly the beginning of July, and watering when the skies do it for you is a waste. Hold off until the soil starts to dry out, and you'll force the grass to look deeper for its water. After summer hits, you should only have to water every seven to ten days, making sure you water deeply.

Grass has adapted to hot, dry summer months by going dormant. A healthy lawn will turn brown when it gets hot, saving itself for the cooler, wetter days of fall. Most of us, however, have little tolerance for a brown lawn in summer, and insist it stay green. Watering will help, but don't expect miracles. Let your lawn rest at least a little during the dog days, and it will respond energetically come fall.

## Quackgrass and Webworms and Grubs, Oh My!

So what about pests? How can you keep the nasty critters off your lawn without using a petroleum-based, nasty-smelling, toxin? Well, if you've worked to enrich the soil, taken it easy with the fertilizer, watered deeply and infrequently, left your clippings and cut your lawn high with a sharp mower, you've probably done it already. Healthy plants make for healthy, pest-free lawns. Grass-destroying bugs and grass diseases see your neighbor's scalped, over-fertilized, shallow-rooted grass as weak, vulnerable, easy prey. They'll tend to steer clear of yours.

If you do have problems, you don't need to hit the chemical bin. You can take care of weeds by hand pulling them. Remember, longer grass will shade them out, and mowing will knock them back — they have a much harder time coming back than grass does. And the thick healthy grass that you're on your way to having will one day choke them out.

You'll need to dig out quackgrass, crabgrass and other wide-bladed grasses once they're established in your lawn. Reseed or allow the rest of your grass to take over the bare areas from where you've removed these weeds, and tend to your remaining lawn carefully. In time, it will thicken up enough to choke out these grasses. A longer lawn will keep crabgrass out, so be careful not to scalp it when you mow.

For webworms and grubs, two of the most common lawn pests, a couple of organic treatments are available. By looking carefully at diseased plants, you'll see the grubs or webworms, which will be busily gnawing off the leaf blades at the crown or chomping through

the roots. Rake the diseased area, and expose the critters. Your neighborhood bird population will soon come in to clean it up. Beneficial nematodes will also work to keep a wide variety of pests at bay. These microscopic animals will attack the pests before they get your grass. You can buy beneficial nematodes through organic gardening suppliers, including Garden City Seeds.

Moles, too, are easily taken care of without pesticides. Moles move in when their favorite foods are present, namely grubs. Rid your lawn of grubs, and you'll rid your lawn of moles. Build up the health of your lawn, use beneficial nematodes, and expose the grubs to the birds, and you'll send the moles off to find grubs somewhere else.

A quick note on dandelions, a discordant note for you dandelion haters: Dandelions, with their deep tap roots, don't compete directly with grass plants. Actually, they benefit the grass by bringing up nutrients from down deep, and breaking up the hard soils below the surface. They're also nutritious greens, and, damn it, have very nice flowers that are as much a part of spring as apple blossoms. But if you must remove them, use a dandelion digger. If you cut the root an inch or so under the surface, they won't come back (much to my disappointment).

Take another look at your landscaping choices. If you're keeping that lawn, try taking care of it without pesticides and store-bought fertilizer. If you give some thought to your mowing, watering and feeding of it, you'll find you have more time to lie on it rather than toiling over it.

Page 62 - Blank

SOME SAGE ADVICE  
ON  
NATIVE-PLANT LANDSCAPING

I confess. I dislike lawns. Well, not every lawn, just the gratuitous ones. I like the ones that have cleat marks, picnic tables and swings, but the ones that just sit there, begging for water, vex me. They get their water, too, by the creekful, along with fertilizer, herbicides and a weekly scalping with a noisy-as-hell, exhaust-belching mower.

As a relatively care-free alternative to gratuitous lawns, I've come to appreciate native plants — species that have lived in the Missoula Valley since the days after Lake Missoula last drained. In the valley, for the most part, we've either paved over the native plant communities or replaced them with needy lawns. These lawns take care — time, water and energy. Uniform and tidy, they demand as much creativity as a paint-by-the-numbers kit and yield as banal a result. I'd like to see us put native plants back in the valley, wherever practical.

You can work native plants into your yard, too. Consider them for sites you don't need in lawn, or for areas with non-native plants for which you'd like to find replacements.

I'll tell you why we've planted part of our property in native plants, and how we went about finding them: by buying container plants, by salvaging them and by seeding them in. I'll also discuss how we maintain the plants once we've put them in, and how we keep the worst of the weeds at bay.

Why? Because We Like Them.

Native plants, adapted to our climate and soils, live on the thirteen inches of precipitation we receive each year, and better than we humans they tolerate the fickle Missoula winters and the dry (well, usually dry) Missoula summers. And they thrive in the cobbled river- and lake-bottom soils that cover the valley floor. Once established, they provide easy-to-care-for landscaping. They know how to live here, so forget about watering or fertilizing — just let them grow. Compare that with a bluegrass lawn, always nagging you for attention.

The native plants living in the Missoula Valley, except those bordering the rivers or in other comparatively wet areas, comprise bunchgrass communities. Bunchgrass, grasses that grow in individual clumps, make up only part of the diverse plant life that once covered the valley. Sage, rabbitbrush, penstemon, bitterroot, yellow bell, several bunchgrass species and dozens of other wildflowers, shrubs, and plants make up bunchgrass communities.

Bunchgrasses grow from a couple of inches in height to several feet tall. The bunches range from a couple of inches across to a foot or more, and they dot the land they grow on like polka dots cover a banker's tie. Unfortunately for the native plants, cows and horses find most bunchgrasses tasty, and eat them like we eat hors d'oeuvres at a party. The bunchgrasses disappear quickly on overgrazed land, making them increasingly rare even on land that hasn't been developed.

## Bluebunch Wheatgrass

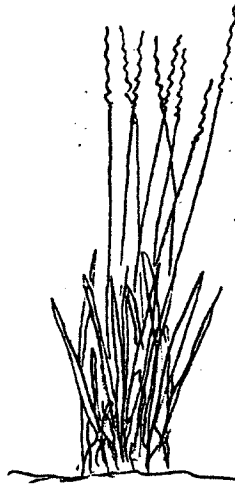

Learning about what makes the Missoula Valley, the place you call home, distinct gives another reason to put in native plants. You'll get a dirt-under-the-fingernails knowledge of which plants are native here and how they grow. I've found I have a much greater appreciation for the peculiar landscape of Missoula, and the arid West in general, since I started learning about what preceded me in living here. I find myself more attached to where I live.

The next time you cruise down the strip see if you can differentiate Missoula from any other chain-store infested American city, well paved and lightly manicured around the edges with grass and a shrub or two. Except perhaps for Torrey's, the weirdly wholesome food island in the Albertson's parking lot (ironically backed up to its antithesis, Little Caesar's Pizza), Missoula's strip is every other town's strip. We might as well be Fresno or Pueblo.

Looking up out of the valley you can see the difference, though. Missoula is ringed with hills: Mt. Sentinel, Mt. Jumbo, Waterworks Hill, Blue Mountain, the South Hills. These hills and the mountains behind them stamp the location on Missoula. And where we haven't yet paved and built on them, these hills still carry the plant life that identifies the Missoula Valley. Allowing these plants to grow on your property will give you a constant reminder of where you live and how it is distinct from other places.

Aesthetics also play a part in my decision to landscape with native plants. If you've wandered up Mt. Sentinel, Mt. Jumbo or any of the other hills around Missoula in the spring, you've seen the rich colors of the wildflowers offset by the green clumps of grass. Think of having this variety of textures and colors in your yard.

Even in the dry days of August, when the native plants have sent their energy back down to their roots awaiting the fall rain, I like how the dry brown clumps of bunchgrass look. Like a well-ordered, or carefully disordered, dried-plant arrangement, bunchgrasses have a form that fits the land. They look comfortable on Mt. Sentinel on a hot August day, and in a cold February snow and wind storm. And they look comfortable in our front yard.

Since I've started working to replace our lawns with native plants, I watch my steps more carefully as I work my way up and down Mt. Sentinel, dodging the bunchgrass clumps and fringed sage when I slip off the trail. I even self-righteously harangue, under my breath, hikers who cut the trails, stomping plants and eroding the soil around them.



You, too, will come to appreciate the native plants as you begin to learn them, and you won't be alone. Birds also enjoy native plants — some animals adapted to the plant life of the valley will revisit the site if you return their accustomed food sources. We won't be seeing pronghorn on the Northside, but we do see pine siskin and grosbeaks. Restoring native plants restores wildlife.

### How to Swap Bunchgrass for Bluegrass

Establishing landscaping with native plants involves more than taking a quick trip to the nursery, chatting with a salesperson, and picking up a bag of seed mix and some plants. You can't roll out bunchgrass sod, and nurseries carry few natives. But don't worry — getting a bed of native plants going takes only as much work as getting a lawn going, and you'll learn something in the process.

How you go about selecting plants depends on how picky you want to be about your landscape choices. Do you want to restore the native bunchgrass community with an aim to return your land to its pre-Missoula status? Do you want to attract birds with seed-producing plants and shrubs for cover? Or hummingbirds with colorful nectar-producing flowers? Do you have native flowers you especially like? Or do you just want to put in what you can get hold of so long as it's native, and let the plants decide which are appropriate for the site by either growing or dying?

We've tried several approaches. We've bought container plants of native species and planted them in, we've collected seed and scattered it, we've taken cuttings and dug suckers from friends'

plants, and we've salvaged plants from sites doomed to be bulldozer's blade.

Container plants give you the quickest, easiest way of planting native species. But this method has limitations: you'll shell out plenty of money for container plants; you may find a native species but the variety may be from somewhere else, making it less adapted to our particular conditions; and you may have the trouble we've had getting some container-grown plants to survive transplanting.

Most nurseries carry native varieties, but only a few. You won't find bunchgrass, and chances are the species you find will be from seed or root stock gathered elsewhere. However, Bitterroot Native Growers in Corvallis has a good selection of native plants and can tell you where their varieties come from. Unfortunately, they concentrate on large-scale restoration work, including strip mines. You may have a tough time getting them to sell you the quantities you want. They do, however, try to make some plants available at the Missoula Farmers Market, and have sold plants from a greenhouse at Garden City Seeds' retail outlet in Hamilton.

We prefer introducing native plants by seed rather than by planting container plants for three reasons: we've been able to start some plants we otherwise wouldn't have been able to since some species won't transplant and aren't available as container plants; collecting seeds has required us to learn the plants, giving us a much better knowledge of what grows where as well as when it blooms and sets seed; and the seed we've collected ourselves has been free.

To collect seed, find a native-plant identification book (you can get hold of several good ones — we use *Vascular Plants of West-Central Montana — Identification Guidebook* by Klaus Lackschewitz, put out by the Forest Service and available at Forest Service Headquarters on Pine and Pattee St., and *Rocky Mountain Wildflowers* by Craighead, Craighead and Davis). Then, once again, take a hike. Seeds start to ripen in May on the earliest blooming plants and continue through the summer. Seeds are ready to collect when they fall easily from the stalk or seed head. Don't over collect, though. You want the seeds, but so do other animals. Leave them some food. And leave some seed for the plants to reproduce themselves. One more caveat: collect from several different plants of the same species to make sure you get some variation in your seed stock.

We plant our seeds the way we expect they plant themselves. We sprinkle them over the ground, lightly scraping the surface of the dirt to allow the seeds to have the protection of bits of soil around them. We plant them in the summer and fall, when they would otherwise fall from the plants that produce them.

Many native seeds require stratification to germinate, meaning they need to go through a freeze-thaw cycle, sometimes repeatedly, before they will sprout. To germinate them, commercial growers put them in a refrigerator for a few weeks, wrapped in moist cloth or paper, and covered with plastic. You can simply plant them in your native bed in the fall, allowing the freezes and thaws of winter to do the work for you.

My favorite way of getting native plants has been to salvage them. Salvaging plants makes sense for several reasons. They're free, they're local and adapted, they'd otherwise be trashed, and we get species we otherwise would never see. Although we've learned many of the local plant species, many are still unknown to us. Take a quick look at *Vascular Plants of West-Central Montana — Identification Guidebook*. You'll find a tome the size of a big-city phone book, crammed full of listings of plant species. Not all live in the Missoula Valley, but thumbing through it gives you an idea of the huge variety of species that do. By salvaging clumps of bunchgrass along with the vegetation surrounding it, we've introduced a surprising number of plants we noticed later and identified as natives.

We've worked with John Pierce, a botanist voluntarily heading up the Toole Park native-plant revegetation project, to find sites around the valley destined for bulldozing. We've gone in before the machines get there, dug up the natives and transplanted them onto our property and in Toole Park, on the riverfront between the Madison and Higgins St. bridges.

These salvaged natives have nearly all taken on our property. Only a few species with tap roots have died. We have Montana's state grass and Montana's state flower both thriving in front of our houses — bitterroots bloom amidst bluebunch wheatgrass in early June.

Watch where you dig your natives though. Please leave alone sites that aren't destined for destruction — we have few relatively undisturbed sites left and I'd hate to lose them. Mt. Sentinel and Mt. Jumbo especially deserve more attention to preserving their native

bunchgrass communities. As these two sites show, bunchgrass community species compete poorly with knapweed and a few other introduced weeds when it comes to reseeding. Once they're gone, they're gone. Instead, target areas destined for development. Ask for permission from the developer before putting potholes in the property, though. Or volunteer to help John with the riverfront plantings, and you'll learn both the native plants and about sites from which to salvage.

If you're curious about when to dig native plants, we've transplanted natives whenever we can get our shovels through the soil. Most bunchgrass community plants grow whenever water is available to them, going dormant during the summer and resuming their growth with the fall rains. They continue growing through the winter when temperatures allow. We've dug and planted in the spring, summer and fall, and the plants have all done well so long as they've had enough water to get them reestablished.

We try to dig a good chunk of root with our plants — a root ball as big around as the above-ground part of the plant and as deep as is practical. With our cobbled soils, though, you won't be able to dig deeply, and the roots of many plants go down into the subsoil as much as seventeen feet. Just get what roots you can.

Plant them in holes as large as the root area of the plant you're putting in, and firm up the soil around them, but don't stomp it down. Give them weekly water during the hot, dry times of the first summer, allowing their roots to become reestablished, and you'll have it.

## Weeding, Watering (and Awithmatic)

Several native plants, bitterroots included, dislike something about our aquifer water, perhaps the dissolved minerals. If you can use rain water (from a barrel under a gutter) or river or irrigation-ditch water, you're natives will appreciate it.

Whatever you do, don't beef up your soil. Native plants like our poor, rocky soils. Weeds usually like better soils, and although the natives will grow in the better soils, so will the weeds. Poor soils will save you plenty of weeding work before the natives take over.

Most common weeds of our area thrive in areas that get plenty of water, including gardens and lawns. Once you cut their water, as you will with a native-plant bed, they'll disappear within a few years. You may need to weed them out for the first year, but the lack of water will soon allow the natives to take over. However, three of the worst local weeds don't fit into this pattern. Knapweed, sulfur cinquefoil and leafy spurge all come from Eurasian climates similar to Missoula's. Coming from dry climates they know how to grow with our amount of precipitation. And because these weeds come from elsewhere, local plant-eating pests don't know them as food. Having nothing to slow them down they out-compete local species.

**Knapweed:** Bee keepers like this Eurasian import because it blooms after nearly every native plant has packed it in for the hot months. It gives the bees mid-summer food. Knapweed is kin to bachelor buttons and resembles this common garden flower. Look for dime-sized pinkish-purple blossoms with ragged petals, coming out in July and August, and lasting into the fall. The plant grows up to three feet tall and has long (up to six inches), thin leaves with rough,

indented edges. Knapweed, a short-lived perennial, has a long tap root and, unless the soil is moist, is as tough to pull as a tooth. Pull it anyway, or as much of it as you can.

Sulfur cinquefoil: Look for a ten- to thirty-inch-tall plant with leaves that have finger-like projections, or petioles — forget your French, cinquefoil has between five and seven. The petioles have rough edges and shock the uninitiated with their resemblance to marijuana leaves. The sulfur comes from the sulfur-colored, half-inch wide, rose-like blooms. If you find knapweed stubborn to pull from dry ground, you'll find sulfur cinquefoil downright obstinate. Cinquefoil, too, you need to make the effort to pull.

Leafy spurge: Growing in patches with stems up to three feet tall, leafy spurge has a distinctive umbrella-shaped top. The blooms have a sickly yellow-green color, and the inch-long, lance-shaped leaves turn an attractive orange-red color in the fall. You can see huge patches of it on Waterworks Hill and on the west side of Mt. Jumbo. You can quickly tell spurge by plucking a leaf — if the torn edges exude a white fluid, it's spurge. Watch it though, some people react to this latex substance and develop a rash. And going beyond the obstinacy of the other two weeds, you can't pull this one out. It's roots go down about twenty feet. To rid yourself of it, find it when it's small (tear a leaf of any plant you suspect of being spurge and look for the latex — you'll be wrong once in a while and damage a plant you want to keep, but you'll learn to tell it soon enough), and break it off at ground level or below if you can. Check the site again every week or two in the summer and keep snapping off the small plants. Before too long it will give up.

Find those spots in your yard where cleat marks are absent, where you wouldn't think of plopping down a picnic table or setting up the croquet hoops. Think of the pleasure you'll get seeing native flowers pop up in the spring, and seeing bunchgrass seedheads waving in a breeze. Plant these areas in natives. You'll have the pleasure of knowing you don't have to mow, and every time you pass the bed, you'll know you're in Missoula.



## STOP THE DRAFT! WEATHERIZE YOUR HOME

Huddled in your armchair, grouching about the cold that keeps you under a blanket rather than sweeping the kitchen floor or writing a long-overdue letter? Grumbling about your heating bill, knowing that come January it will cost you more than a month's feed for a Doberman? Here's how to warm up and save energy without hiring a professional to help out.

The most important step you can take to keep your home warm using less heating fuel and saving money on heating bills is to adopt three dozen rabbits and have them hop vigorously about your home, thereby heating it. No, wrong. Sorry. Weatherize — by properly weatherizing your home, insulating and sealing off drafts, you can dramatically increase your comfort and decrease your heating costs.

We've taken the two houses on our property and worked to weatherize them, trying out many different materials and techniques. We've looked into types of insulation, what we need to insulate, how to install the materials, how to cut drafts from sneaking through and around window and doors, and how to get financial and technical help.

### More Bats, Less Fueling — Insulating Your Home

Insulating your house is like covering your torso with a jacket — it means trapping pockets of air around a heated space to prevent the warmth from escaping to the cooler outside. Your jacket keeps

your body heat trapped, just as well-insulated floors, walls, windows and ceilings of a house keep it comfortably warm using less energy.

Building insulation comes in three general types: loose, bat and rigid foam.

Loose insulation is the fluffy stuff typically blown into walls and attics, and often made from cellulose (recycled newspaper or wood fibers) treated to retard fire. You can use it to fill gaps between rafters (the wood beams that support your roof) or studs (the wood beams that run vertically inside your walls and hold up the wall surfaces).

Bat insulation is made from the hides of small flying mammals. No, wrong again. It's the pink rolled stuff hawked by the pink panther, who has been reduced to crass commercialism after the demise of his benefactor Peter Sellers. Made from spun fiberglass or mineral wool (ever tried to shear a rock?), it often has a foil backing, and you can roll it out between rafters in your attic or between floor joists (the wood beams that support your floor boards).

Rigid foam insulation uses petroleum products — plastics — to create plywood-sized sheets of insulating material you can slap up over flat surfaces including cement walls, foundations and ceilings.

You can tell the insulating value of your material by checking its R-value, a statistic stamped onto the product or its packaging. (I've included R-values for unlabeled or scavenged insulation in the table following this discussion.) R-value indicates the heat resistance of the material, the ability of material to keep heat from passing

through it, calculated per inch of product. Standard building materials have R-values between 0.5 and 1.0, which means they pass on the heat from one side of them to the other like a sneeze passes a cold. They help little when placed between a 65-degree living room and a 14-degree yard. Insulating products have R-values between 2.1 and 7.7, offering substantially more resistance to passing heat. Remember R-values indicate resistance per inch, so adding inches multiplies the resistance (three inches of R-3.5 equals R-10.5).

### R-Values of Common Insulating Materials

Mineral Wool Bats	3.5
Fiberglass Bats	3.1 — 3.5
Mineral Wool (Loose Fill)	2.8
Cellulose (Loose Fill)	3.1 — 3.7
Vermiculite (Loose)	2.1 — 2.3
Perlite (Loose)	2.3 — 2.7
Polystyrene Boards (Rigid)	3.6 — 5.3
Polyurethane Boards (Rigid)	5.8 — 7.7

(from *Do-It-Yourself Home Weatherization Guide*)

### Vapor Barriers

Insulation often comes with a vapor barrier attached, especially bat type, which often comes with foil attached to one side. A vapor barrier keeps the air on the two sides of it from mixing, somewhat like what an inversion does to Missoula's air. With insulation, the vapor barrier keeps moisture-laden air inside the

insulated area from mixing with cooler, dryer air outside, and thereby preventing condensation and water damage.

Warm air holds more moisture than cold air. In your house cooking, washing dishes, and bathing put warm, moist air into the air. When warm air contacts cold air and starts to cool, the moisture comes out as condensation. In your home, this condensation can collect in insulation, waterlogging it and causing the wood around it to rot. It can also become so heavy it can bring down a ceiling.

By placing a vapor barrier between a heated area and the insulation, you keep the warm, moist air from contacting the cool, dry air and prevent condensation problems. If your insulation comes without a vapor barrier, you can use plastic sheeting. If you have spaces insulated without a vapor barrier and you decide not to put one in, make certain they have adequate ventilation across the cold side of the material so condensation won't cause problems.

### What to Insulate

Look up. That ceiling looks downright passive, but don't let it fool you. It sucks heat away like a kid with a crazy straw slurps chocolate milk. More quantitatively, the Bonneville Power Administration (B.P.A.) in their *Do-It-Yourself Home Weatherization Guide* (available free at the Missoula Public Library) states that up to 45% of a uninsulated home's heat goes up through the roof. This heat waste warrants some work to hold it in.

Try walking across your floor barefoot some winter day and if your home is like mine, your toes, like a mood ring, will change from pink to violet. Uninsulated floors over unheated basements or crawl

spaces waste heat. As the heated air in your house rises and escapes, cold air can come in through the foundation and straight up through the floor, freezing your feet. The B.P.A. suggests insulating floors or basement walls to R-19.

Walls, too, can bleed heat, and the B.P.A. suggests R-11 insulation for them. But if walls can bleed heat, windows can hemorrhage. Poorly installed, single-pane, or weathered windows with leaky frames not only leak heat, but often allow drafts to flow through your home. And these drafts, even if they add up to little direct energy loss, make you feel damn uncomfortable — tempting you to crank up the thermostat to compensate for the chill you feel. And there comes further energy loss.

Pipes and ducts, too, need insulating. You can lose more heat to the air from an uninsulated hot-water pipe than arrives at a faucet, and water heaters consume a large portion of a home's energy. You need to insulate air ducts when they travel through unheated spaces, for the same reason.

Last winter I returned to Missoula from a long vacation and found the cold weather had infested my plumbing, freezing it up and splitting several pipes. I opened a trap door through my bathroom floor to thaw my pipes and replace some pieces, and left it open overnight to allow some warmth to get to them. Roused by my bladder in the wee hours I shuffled to the bathroom and, with one arm reaching for the light switch, I dropped through the open trap door, meeting the toilet with my ribs on the way down. Don't let this happen to you — I suggest saving fuel, time, money, and cartilage by wrapping your pipes. B.P.A. suggests using R-3 or higher insulation.

## How to Insulate

Insulating can involve fiberglass rashes and dust-blackened snot, but it also means less energy waste. And the discomfort of a day's work in the attic is a small price to pay for a winter of cozy comfort.

Simply stated, you line the warm side of the area you are insulating with a vapor barrier, then spread the insulation on the cold-facing side. For an attic, this means the insulation goes between the vapor barrier and the roof or under the insulation on the floor of the attic. In the basement the vapor barrier goes directly under the floor with the insulation below it for an unheated space, or the insulation is sandwiched between the basement walls and the vapor barrier in a heated basement.

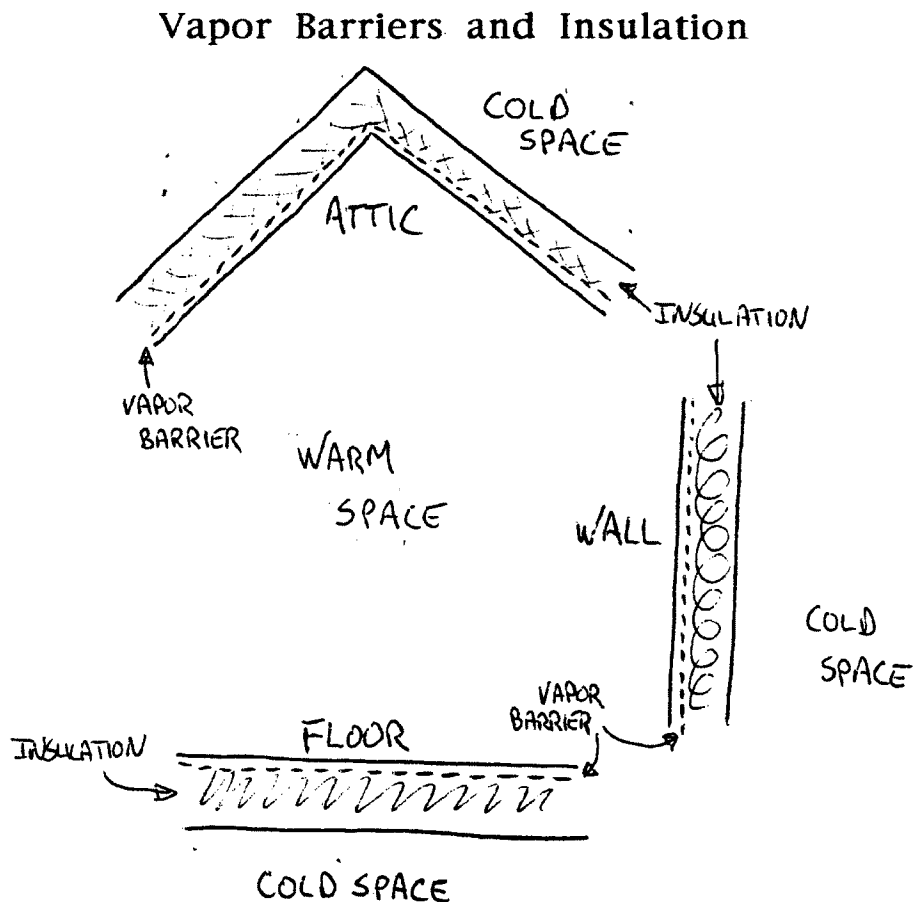

We've dumped bagful after bagful of scavenged loose-fill insulation into the attic space of one of our homes, the one with the rib-eating trap door. Since insulating the attic, I've had no problem with frozen pipes, even at outdoor temperatures below previous pipe-freezing cold snaps. True, I had to wear a dust mask to avoid sucking in old dust while I spread the stuff, and I emerged from the attic with dark grey skin. But I'd rather wash off layers of dust than drop through the floor.

To find the number of inches of insulation you need to apply, first find the R-value of the insulation you will use. Then divide the R-value to which you want to insulate by this number, and you have the number of inches you need.

Windows lend themselves to a variety of insulation options from cheap, easy and fairly effective (if somewhat unsightly) to expensive, difficult and extremely energy efficient.

On the cheap end, you can do wonders with duct tape and plastic. Try either taping or nailing with wood lath (thin wood pieces) plastic sheeting over single-pane windows you won't be opening in the winter, leaving a few-inch gap between the glass and the plastic. The air pocket you create between the two will be your insulation. You can easily scrounge plastic from furniture outlets, which bring in their mattresses and other home furnishings heavily wrapped. They toss the plastic and usually give it away gladly rather than send it to the dump.

If you don't like the opaque plastic or the look of duct tape or lath, you can buy transparent plastic shrink-to-fit kits at hardware

stores. You apply the plastic to your window frames with the aid of a hair dryer — the hair dryer's heat shrinks the wrinkles out of the plastic once you've put it up, and you're left with an insulated window nearly as clear as it was when uninsulated.

More expensive are various insulating shutters and curtains. These work by trapping air much like the plastic sheeting, but often have additional insulation built in and also work in the summer months to keep out the sun's heat.

Putting up storm windows costs more, but provides a more permanent option. Make certain you seal the storm windows so air can't leak around the glass or frames. Likewise, replacing existing single-pane windows with more expensive multi-pane units will save energy, although it will take many years of energy savings to pay back the cost of the windows, more years than with other energy saving options.

To learn more about window insulation systems, check out another free publication, *Window Insulation, How to Sort Through the Options*, put out by the Montana Department of Natural Resources and Conservation and available through the county Cooperative Extension Office on Alder St.

You can insulate pipes wrapping them in a spiral fashion with fiberglass insulation strips, overlapping the strips by one half as you go around the pipe. Or, you can use foam pipe-insulation sleeves, which simply slip over the pipes. Insulate ducts just as you do any other space in your home, making sure the joints between sections of ductwork are sealed with duct tape so air can't escape.



We've had good luck scavenging insulation. Contact contractors who are dismantling buildings, and see if they are removing either loose fill or bat insulation. Both, although dusty, are easily reused.

For helpful drawings and step-by-step help in applying insulation, pick up a copy of B.P.A.'s *Do-It-Yourself Home Weatherization Guide* at the library.

### Gone with the Wind

Experts disagree on how much energy a poorly sealed house — a home with air seeping in around doors and windows and through other gaps — wastes. Montana Power says air infiltration is the most wasteful yet easily correctable problem a homeowner or renter can fix. Consumer Reports, in its October 1993 issue, states that drafts play only a small part in overall energy loss (but drafts make up only a part of air infiltration). So much for the experts. I say, when I feel a cold draft creeping up the back of my neck I'm eyeing the thermostat, ready to crank up the heat. Even if drafts cause little direct heat waste, turning up the furnace does.

For comfort reasons, weatherization to cut drafts makes sense. And since it's cheap and easy to do yourself, chances are it will save money, too. Weather-stripping, caulking, and otherwise sealing your home from drafts and air leaks comprise most of the work you can do to seal your home.

Meant to block drafts from creeping around doors and windows, weather-stripping comes in a confusing array of designs and materials. To dispel the confusion, Consumer Reports, in the October 1993 issue, went to the trouble of buying, installing and

testing all the products they could get their hands on, and distilled their test results down into one tidy table. To further distill the information, here are my recommendations:

Doors: EPDM rubber tape is an easy to install, self-sticking foam-rubber-like material that seals well in houses like mine where nothing is square or even and flexibility is essential. I have reservations about the adhesive, though — they stick for a while for me, then lift off. Plus, just what is ethylene-propylene-diene monomer, and what other polysyllabic compounds get spewed out in its manufacture? Other options include reinforced silicone, which works and lasts well but can be a pain to install, and tubular rubber and vinyl, which work well but wear out more quickly. Last on Consumer Report's list, and making a poor showing around the doors of my house, is reinforced felt, which does everything well except seal.

Door bottoms: Vinyl door seals with several separate sweeps top Consumer Reports' list. I've tried a few different designs, and agree — the single sweep varieties cost less, but leak, and the vinyl sweeps seal better than felt.

Windows: If you're not going to be opening the window during the cold months, seal it off with plastic, tape, or rope caulk (a clay-like material that comes in pencil-thin strips you can press into gaps with your fingers — a do-it-yourselfer's play dough). Tack up scavenged plastic with wood lath (thin wood strips) leaving a couple-

inch gap between the plastic and glass and making sure the plastic is well sealed. Hardware stores also sell the plasticizing kits with less opaque material that seals your windows like shrink wrap.

If you plan to be opening your windows, you can still weatherize them by helping them close more snugly. Consumer Reports recommends plastic tension seals, or v-seals, that fit snugly between windows and their frames. Most of the materials that work around doors will also work around windows.

Window and Door Frames: Air can flow in around door and window frames alike. Weatherize these with caulk, a goop-in-a-tube that, with minimal skill and a \$5.00 caulk gun, you can direct into cracks and gaps around your home. It hardens into a still-flexible sealant that will stop air and water from creeping into your wall. Caulk, like paint, comes in many types. You have a choice of latex, silicone, acrylic, butyl and various combinations of the four.

Consumer Reports, again in its October 1993 issue, rates a couple dozen varieties as to their flexibility, resistance to mildew and dirt, and how well they weather. I suggest, after getting gassed by the solvents in the non-latex varieties, to stick to (figuratively) the water-based types. These latex and silicone/latex varieties work well, don't require paint thinner for clean up, and don't leave your house smelling like a refinery for the three days until they've cured. And when you perform the inevitable elbow in the goop trick, you can wash the stuff out.

Free Help

To further assist you in weatherizing your home, Montana Power Company has several assistance programs.

**Free Energy Audits:** MPC offers a limited number of free energy audits for homes they supply with gas or electricity. Their priority is cutting electric use, but they also help out gas customers, giving priority to those with exorbitant bills. The auditors will install low-flow showerheads and sink aerators (to cut water and hot water use); put in compact fluorescent light bulbs (which use about 1/5 the electricity of standard incandescent bulbs); help with weatherstripping, caulking, and door sweeps; wrap water heaters; test appliances for carbon monoxide fumes; test your home for air infiltration; and give you written recommendations of further energy saving measures you can take. To set up an audit, call MPC at 549-2301.

**No-Interest Loans:** As part of their energy audit program, MPC offers no-interest loans to homeowners for cost-effective energy conservation measures recommended in the audit reports. These loans usually go for insulation, sometimes for new heaters, and rarely for window replacement.

**LIEAP (Low-Income Energy Assistance Program):** MPC, through Energy Share, provides money to the Human Resource Development Council (HRDC) to help low-income residents (owners and renters) cut their energy bills. HRDC prioritizes the people they help by evaluating the condition of the applicant's home, the energy consumption of the residence, and applicant's income. The program offers weatherization help and assists some low-income residents

directly with their energy bills. The program provides assistance to people whose income are less than 150 percent of the federal poverty level. You can request an application from HRDC, 617 S. Higgins in Missoula, ph: 728-3710.

So stop your grouching, and start weatherizing. Not only will you make your home more comfortable, but you'll warm yourself with the activity.

## ALTERNATIVE ENERGY

### GIZMOS AND GADGETS THAT SAVE ENERGY AND MONEY

Today we started hooking up a strange mix of salvaged and donated materials into a system that uses sunlight to heat my house. We've accumulated a Sanford and Son's pile, with pieces of coolers, corrugated fiberglass roofing, metal pipes and plumbing scraps. We're molding the mix into an alternative energy system we can use to shrink our dependence on Montana Power.

This system is one of several experiments in alternative energy we're playing around with at the M.U.D. project. We've been trying to convert salvaged materials into home-built technologies for some time now, and we've been investing in other technologies we have yet to figure out how to build ourselves, when they save energy. We do it for several reasons. We're curious, and we enjoy putting odd things together and trying to make them work. We want to live here as responsibly as we can, trying to rethink and reduce our part in our culture's reliance on damaging energy-generating technologies. And we want to live less expensively, cutting our energy expenditures so we can use our time for things other than making money to pay for electricity, natural gas and petroleum.

Whether you resent your utility bills and the costs of your car, or your reliance on petroleum products and all it entails, investing in alternative energy technologies can ease your worries, too. Although simply changing your habits when it comes to using energy can save more than investing in alternative technologies, these gizmos can help. So go ahead and turn down your thermostat at night,

weatherize and insulate your home, turn off lights and appliances when you're not using them, and ride your bike and walk when you can — then look into investing a bit to further your energy savings.

### Choosing Alternative Technologies

Deciding which alternative energy technologies to explore and invest in often winds up more difficult than understanding the intricacies of how they work. Once you've decided that you want to explore the options, how do you go about finding out which options to explore?

We've based our decisions largely on serendipity. We've latched onto alternative technologies others have introduced us to or we've stumbled across, when they fit with what we can afford and when they provide a less resource-intensive alternative. To date we've experimented with technologies that offer alternatives to home heating, MPC-provided electricity, conventional water heaters, electric and gas ovens, automobiles for around-town use, conventional lighting, and bathroom sinks.

We look carefully at the cost of the alternative, first seeing if we can afford it and then evaluating the long-term cost. With alternative technologies people talk about the pay-back period, the amount of time your new technology takes to save in energy costs the amount money you payed for the item. We, too, look at the pay-back period, but we also take a hard look at the up-front cost and our scant budget.

### Electricity from Sunlight

Active solar, the media darling of alternative technologies, is a glamorous but expensive, complicated, high-tech alternative. Active solar generates electricity from sunlight, and can potentially wean us completely from electric utilities and gas-powered vehicles. But don't hold your breath. You'll be bluer than a huckleberry before active solar allows us to maintain our current high energy consumption and automobile dependent lifestyles.

Solar electric technology has a high price tag, and, not surprisingly, its cost is multiplied by the amount of electricity you want it to produce for you. Solar panels cost plenty, as does the various electronic hardware you need to buy to get them to feed your lights and appliances. And since you'll probably prefer turning on your lights when the sun isn't shining and the panels aren't cranking out the current, you'll need a bank of batteries to store the previously generated power.

Living in Missoula, with our sunless winter skies, gives us an additional problem. Solar systems have their own form of Seasonal Affective Disorder, and you'll need to invest in more storage ability to make up for the lack of recharging from the sun in the wintertime.

Solar electric systems at current electricity rates cost more to purchase and set up than you will save by avoiding MPC electricity bills, assuming you're on the grid. For remote locations, where you have to pay through the nose for the electric company to wire you up, solar makes sense. And for some specific applications, such as running a greenhouse fan, these panels are worthwhile investments.

We have six large solar electric panels feeding electricity to five batteries, which in turn power the lights and computer of our



office, and a large portion of one of our homes. We've benefited from a loan of part of the gear and discounts on most of the rest of it, allowing us to try out the technology. Even with the help, the solar setup still took a chunk out of our budget, and it will take years to repay in savings on utility bills, assuming our batteries last.

More practical but less glamorous are the other solar electric setups on our property. We ventilate our sun-heated greenhouse with a solar-powered fan — a small fan hooked to a small solar panel. This setup works without a battery since we only want the greenhouse cooled when the sun shines, eliminating the weak link of the system. New, this setup costs about \$300.00.

We've also rigged up a solar setup to run a portable lap-top computer. The panel for this operation costs only about \$50.00, and the computer has its own battery for the panel to charge.

Last, we have a rechargeable battery charging system. Transporting ourselves around town on bikes requires us to have battery-powered lights for night riding. Since we're reluctant to buy, use and toss standard batteries, which have extremely toxic ingredients, we've bought rechargeable batteries. We have both small solar chargers, panels the size of index cards, to recharge our batteries, and a charger hooked into our home-power setup. The low cost of a battery charger (\$15.00 to \$30.00, plus \$2.00 - \$9.00 per AA battery, depending on quality and toxicity) makes economic sense when you add up the cost of piles of disposable batteries.

Give this technology time, though. Solar systems will someday become cost effective for ordinary electrical applications. Electricity rates will climb, and solar panels have plummeted in cost over the

past decade or so, as has much of the rest of the gear you'll need to set up a system. What's still to come is the battery technology.

Currently, pardon the pun, batteries are expensive, easy to ruin, built with toxic materials and heavier than black holes. Plenty of money and effort is going into research on new battery technologies, which should eventually increase safety, reliability and efficiency and bring down costs.

If you're considering trying out a solar electric setup, remember that the larger the load, the more expensive the gear you'll need. Start by reducing the amount of electricity you use, a wise move even without hooking up to solar panels.

Solar electric setups can power light bulbs and other low-wattage appliances fairly well, but when it comes to powering refrigerators, freezers, electric heaters, washing machines and even some small appliances like toasters, you'll wind up investing a bundle on batteries. However, you can find newfangled relatively low-energy versions of home appliances. You'll pay several times more to start with, but again, they'll pay you back in energy savings in the long run. Better yet, learn to live with fewer appliances.

Our system can power lights and low-power appliances like computers, stereos, T.V.s and V.C.R.s, but won't handle a refrigerator or freezer, or even a toaster oven. These take too much power, and until we spring for the expensive, energy-efficient appliances, we're stuck on the grid powering these items.

### Compact Florescent Light Bulbs

An easy way to significantly cut your electricity use is to install compact fluorescent light bulbs. MPC has been offering reduced-price compact fluorescent light bulbs on and off for a year or so — if you haven't yet taken MPC up on its offers, do so. Compact fluorescent bulbs save 80 percent of the electricity of a conventional incandescent bulb and last up to 15 times longer. Even at full price (around \$15.00), these bulbs make sense financially. At the subsidized prices MPC offers, they're a deal to jump at.

We've installed compact fluorescents in nearly every socket in our homes. We've tried over a half-dozen varieties, and we have some clear preferences as to size and quality of light. Check out the quality of light the compact fluorescent bulb you want to use. I avoid the circular bulbs that glow like halos around a central balast (the part that sparks the light). Although I can't tell most compact fluorescents from standard incandescent bulbs, but these space-station-shaped bulbs give off the glaring white fluorescent light that brings on memories of dreary days in school cafeterias. Also check the size of the bulb. They sometimes are too large to fit in fixtures, so go with the style that fits the function.

### Electricity from the Wind

Wind energy provides another potential alternative to the grid but again requires heavy initial investment and has some drawbacks for Missoula Valley use. You need to put wind generators up in the wind, above the tree and roof lines of an urban area. Your neighbors and the city building department may balk at the idea of a forty-foot eggbeater whirring above your home, and you'll need, for your own

peace of mind, to make sure your apparatus stays vertical during Hellgate winds.

We helped our across-the-street neighbor set up a wind generator, mounting it on a thirty-foot pole in her back yard. The raising of the steel pole turned into an adventure beyond what she had expected, and we quickly took it down. Cities have power lines in the way of falling poles, as well as porches, cars and chimneys. The wobble in the pole convinced our friend to shorten her pole, even though it meant less efficiency due to broken wind patterns below the tree and roof lines.

A further problem with wind-powered generators is that since they spin, they have moving parts. Moving parts wear out, and they need maintenance. A friend of ours on the east slope of the mountains between Great Falls and Helena tried a wind generator for several years, but ditched it when it repeatedly chose to break down in the winter. Climbing a thirty-foot pole in below freezing temperatures with the wind whipping by convinced my friend to try solar panels instead. Again, look for improvements in wind-generator designs, but consider them more for rural applications than urban.

### Getting Aggressive about Passive Solar

Moving down the price scale for alternative technologies, we've run into a variety of passive solar items. Passive solar items trap the sun's heat, using it to warm water or air. Most household uses have it either supplement or replace conventional water heaters and furnaces. Even with Missoula's winter skies passive solar makes sense, although with our lack of winter sun, supplementing rather

than replacing conventional air or water heating is probably the best we can hope for.

Our passive-solar heating system, the scrap-pile compilation, starts by heating water in a passive solar panel — a panel containing copper tubing covered by copper foil, all painted black. The sunlight shines through a sheet of transparent fiberglass on the front, and the black-colored metal absorbs its heat. The metal transfers the heat to water flowing through the tubing, and the tubing transports the heated water to a storage tank. The water flows from the storage tank through a radiator with a fan behind it. The fan blows air over the radiator filled with hot water, thereby heating a portion of my house.

Passive Solar System

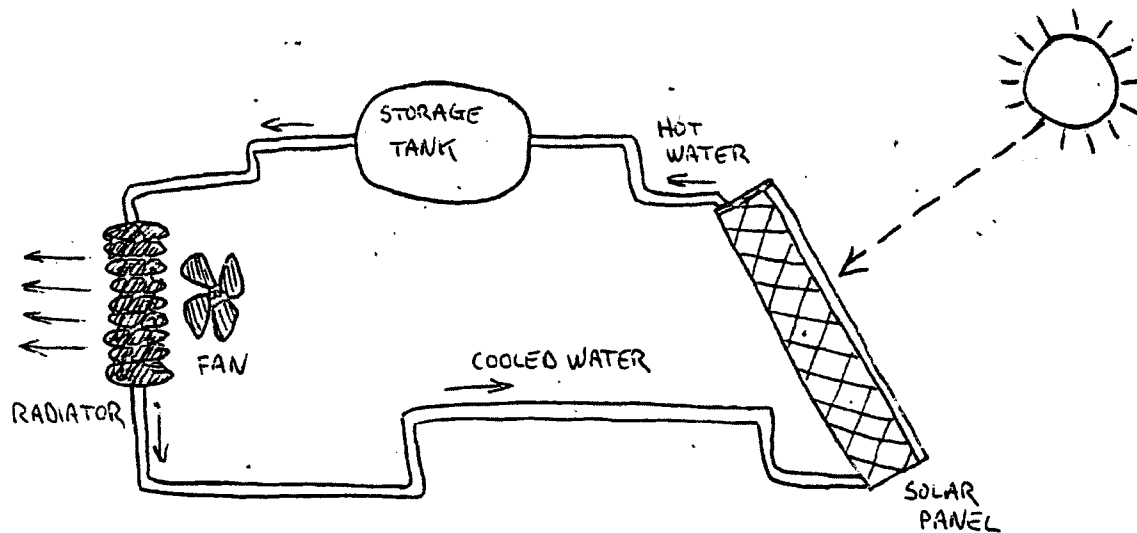

The water flows through the system by convection — since heat rises, the hot water flows up through the solar panel, out the top and to the storage tank. The water flowing up pulls water into the bottom of the panel, which is connected to the bottom of the radiator. The

water leaving the radiator pulls water from the storage tank to the radiator, where the fan cools it down as it moves through the coils. This cooled water then flows back to the panel, where it heats up again, ready to resume its journey.

The only part of the system that requires electricity is the fan, but we'll make the sun do that work, too. We'll take a trip to the junk yard, find a car with an intact fan assembly, yank it off and install it in our system. Car electrical devices run off car batteries, which are 12 volt, direct current (abbreviated DC), power sources. Solar electric panels also produce DC power (different from the 110 volt, alternating current, or AC, power you get from the utility company), which most owners store in 12-volt batteries. So, with a solar panel, we can power our fan, and since we only want it to run when the sun shines, and water is flowing through our hot water system, we won't need a battery.

The other parts of the system came from a variety of sources. Back in the seventies, the era of grand and glorious plans for solar energy, with the government shelling out the dollars to help the industry, Missoula had a branch of AERO, the Alternative Energy Resource Organization in town— a Helena-based non-profit that works to promote alternative energy and alternative agriculture primarily in Montana. AERO West had an office on Spruce St., next to the current City-County Health Department, and provided an alternative-energy library and workshops to local residents, as well as having a series of passive solar panels mounted on its roof that it used to heat its office and library. AERO West went south with the alternative energy funding crash of the early 1980s, and the solar

panels went into the garage of Scott Sproul, one of AERO West's founders. Thanks to Scott, one of these panels now lives at M.U.D., and we're working to again make it a demonstration.

The heating unit to which we will hitch the solar panel came from an old walk-in cooler in a food supplier's warehouse bought by Mountain Press Publishing. Since books store well without refrigeration, Mountain Press gave us salvage rights to the cooler assembly and a batch of copper tubing plumbed into it. Previously mounted on the ceiling, the cooler mechanism is a simple radiator with a fan behind it. Coolant flowed through the radiator and the fan blew air across the coils, refrigerating the walk-in space. Unfortunately for our ozone, the coolant had escaped its system and had headed up to do its damage. We took down the radiator and fan assembly and will pump the hot water that comes from our solar panel through it, having the fan blow air across the coils and heat our space.

Touring the city, you can see many passive solar systems operating on both homes and businesses. Dredge up your memories of the oil boycott of the seventies and the Carter-era energy credits, and you'll see its remnants. These technologies were more than tax write-off boondoggles, usually. They worked, and many still do. And even though the government first trashed the tax credits and then largely ignored the technologies during the twelve subsequent years, passive solar still makes economic sense. You can, with a significant but not exorbitant initial investment, purchase (or build) and install a passive solar system on your home. Depending on the system you

choose, your initial investment can be repaid in a few short years with the money you save on your energy bills.

Systems with similar objectives to the one we built but with tested results, are available from solar supply companies, if you are reluctant to try making one yourself. They cost upwards of \$2,000, plus installation.

Much of the world has been introduced to another solar technology that we in the US. rarely see. Solar cookers give a fuel-free alternative to other ovens, and cost relatively little to buy or build. We've tried one out and have found it can heat up to 450 degrees when in direct summer sun — hot enough for almost any cooking you want to do.

Our cooker consists of an insulated plywood box about two feet square, lined on the inside with foil. The cooker has a door in the front, just like any other oven, but the lid lifts up, revealing a glass top over the foil-lined cooking chamber. The lid, hinged at the back and also covered with foil, props up over the chamber. When you set it in the sun, the lid reflects sunlight down into the chamber and the oven heats up, dramatically. For demonstrations, cookies make for the most favored baked items, but we've also tried grains — rice and bulger — that have also worked well.



## Solar Oven

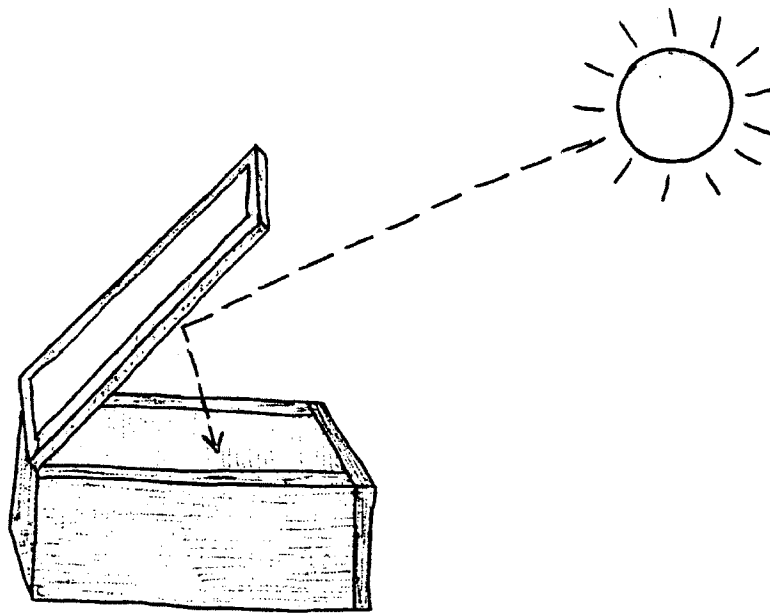

Through the spring and summer crops come in en masse. Fruits and vegetables come in floods at M.U.D. Wanting to use all we can of our crops, we've looked for ways of preserving what we can't consume immediately. We can some foods, but canning takes canning jars, lids and rings, canners and pressure canners, and plenty of power to boil plenty of water. And canned foods often lose their pleasant textures and flavors when put through the rigors of water baths. We freeze some produce, too, but freezers only hold so much, and take their own share of energy. We've added one more home-built technology to our energy-saving repertoire to avoid some of these problems: a solar food dryer.

Our solar food dryer is a box with a chimney. We took an old herb dryer, a plywood box with screen shelves, and painted it black to absorb the heat of sunshine. To add to its heating, we attached an air chamber to the bottom, a glass-fronted sloped tube painted black on the inside. Sunlight goes through the glass and hits the inside of

the tube, the heat is absorbed by the dark-colored interior, and the air in the chamber heats up. Because hot air rises, air travels up through the tube, into the box holding the shelves, over the food on the drying screens and out a vent at the top. In the process, the food dries.

As insurance for cloudy days, we've installed three light bulbs in the bottom of the dryer, with foil shields between the bulbs and the drying racks to protect the food from too much heat. The light bulbs produce enough warmth to maintain the temperature of the dryer, so food won't rot when the sun doesn't shine.

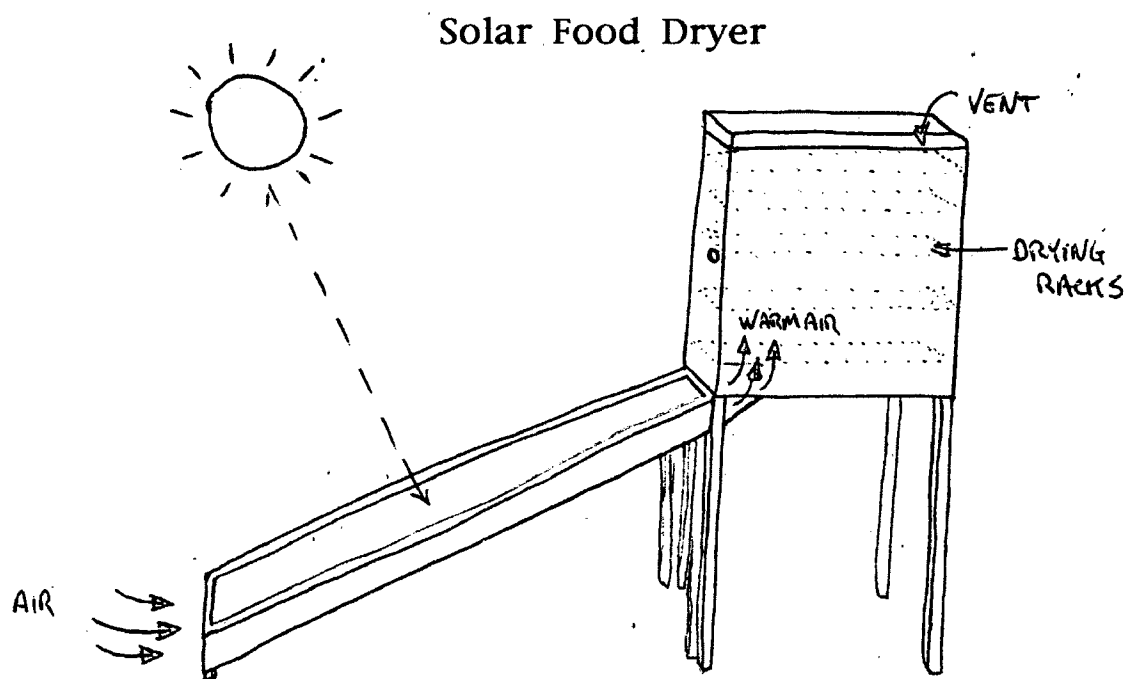

### Alternative Bathroom Technologies

Bathrooms provide useful sites for other alternative technologies: on-demand water heaters, toilet sinks and low-flow shower heads.

On-demand water heaters are standard in countries with more expensive energy costs. Travelers to Asia and Europe will see metal boxes, about three feet tall, two feet wide and eight inches deep mounted on the walls of bathrooms. These boxes replace the storage tank water heaters to which we in the US. have grown accustomed.

Instead of keeping a volume of water hot, on-demand heaters heat up water only as you need it, saving the energy otherwise lost to the air. The heaters have a series of gas jets underneath a radiator. When you turn on a hot-water spigot, water moves through the radiator and the jets turn on, blasting the water with heat. By the time the water leaves the heater and heads toward your faucet, it has been heated to the desired temperature. As soon as you turn the water off, the gas jets turn off.

We installed one of these heaters on our bathroom wall three years ago, replacing a new but expensive-to-run electric storage tank heater. We allowed the water to first flow through the unplugged water heater, letting the heat in the room to warm it up passively, then plumbed it on to the on-demand heater. It now provides all the hot water to our admittedly small house, including a bathtub and shower. We noticed an immediate two-thirds reduction in our electric costs, without a significant rise in our gas use. We figured we paid back the cost of the machine, which we bought at a significant discount, and the rest of the installation materials within two years. At full price, the pay-back period would have been longer, but still less than five years.

We had to cut a vent hole in our bathroom ceiling and up through the roof for the exhaust pipe and plump both water and gas to the heater, which challenged our beginning plumbing and building skills, but we were still able to do ourselves. The heater itself takes up only a little more room than a medicine cabinet and bolts easily into the wall.

The whole operation, heater, vent and plumbing parts, will cost you less than \$1000.00 to install yourself for a heater the size of ours. Larger units for larger houses are available, as are smaller units for single sinks or bathtubs.

You can also cut water use in your bathroom significantly through alternative technology devices, although once again, changing your habits will cut usage just as much without costing you a penny. Shorten your time in the shower, turn off the water when you're brushing your teeth and shaving, and drop a two-liter plastic pop jug, filled with water, in your toilet tank. Then take a look at alternatives to invest in. And although our fast-moving aquifer offers us plenty of water here in the Missoula Valley, it still needs to be pumped and transported, involving significant energy use. Wastewater treatment involves more energy use.

Start with your shower. Installing a low-flow shower head, which breaks the water into tiny droplets, can cut water use by 75 percent without sacrificing comfort. Likewise, installing sink aerators on faucets will significantly cut water use without changing the practicality of the spigot.

Beyond adding a pop bottle to your toilet tank, which cuts the amount of water needed to flush the toilet by the amount of water

contained in the bottle, you can install a toilet lid sink. These devices, which I've been told are popular in Japan, send the fresh water that normally goes straight into the toilet tank after a flush through a faucet and sink that replaces your toilet lid. You have fresh water to wash your hands, and the gray water drains through the sink and into the storage tank, readying the toilet for another flush.

### Toilet Lid Sink

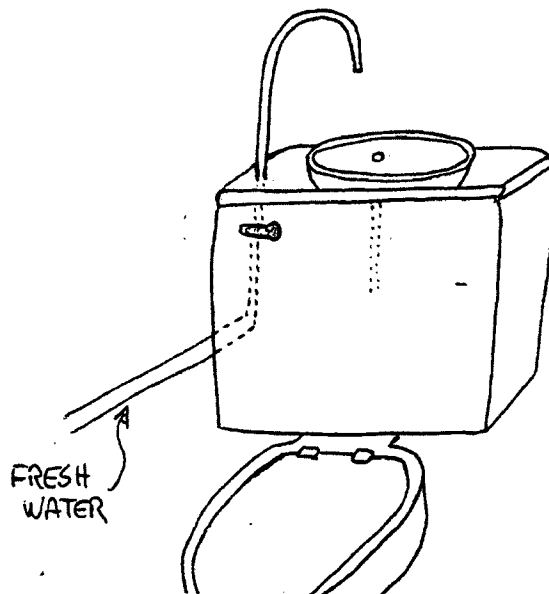

We've used our toilet lid sink for over a year now, in a bathroom the size of a broom closet. We struggled with ideas of how to find room between the toilet and the shower for a sink, but never figured out how. Spotting the toilet lid sink in an alternative energy catalog led to the solution. We saved space and water, and have even prompted others with sinkless bathrooms to try their own.

### Alternative Transportation

After leaving your bathroom in the morning, think about how you're planning on transporting yourself around town. Walking gives you a free alternative, if you don't count the cost of the shoes, and bicycling, too, offers a relatively cheap alternative. For the cost of a year's automobile insurance, you can buy a good quality used mountain bike.

But what about hauling groceries, or taking kids to school? Well, don't count bikes out too soon. Bike carts fulfill many of the functions of automobiles. Our homemade bike cart, costing about \$80.00 in parts, has hauled 300 lb.. of potatoes across town. Although that much weight took some effort to maneuver, carrying a load of groceries poses a minimal challenge. And hauling a kid too young to ride her or his bike would cause little problem. Think of the satisfaction you can have about not contributing to the lung-clogging brown mass of air hovering over our valley most of the winter.

We built our bike cart out of steel tubing; nuts and bolts; two used twenty-inch bicycle rims, tires, tubes and axles; a bike trailer hitch (about \$8.00 at the bike store), a partial sheet of used plywood, and a couple of yards of used cloth. Check the diagram for a quick idea of how ours went together.

# Home-Built Bike Cart

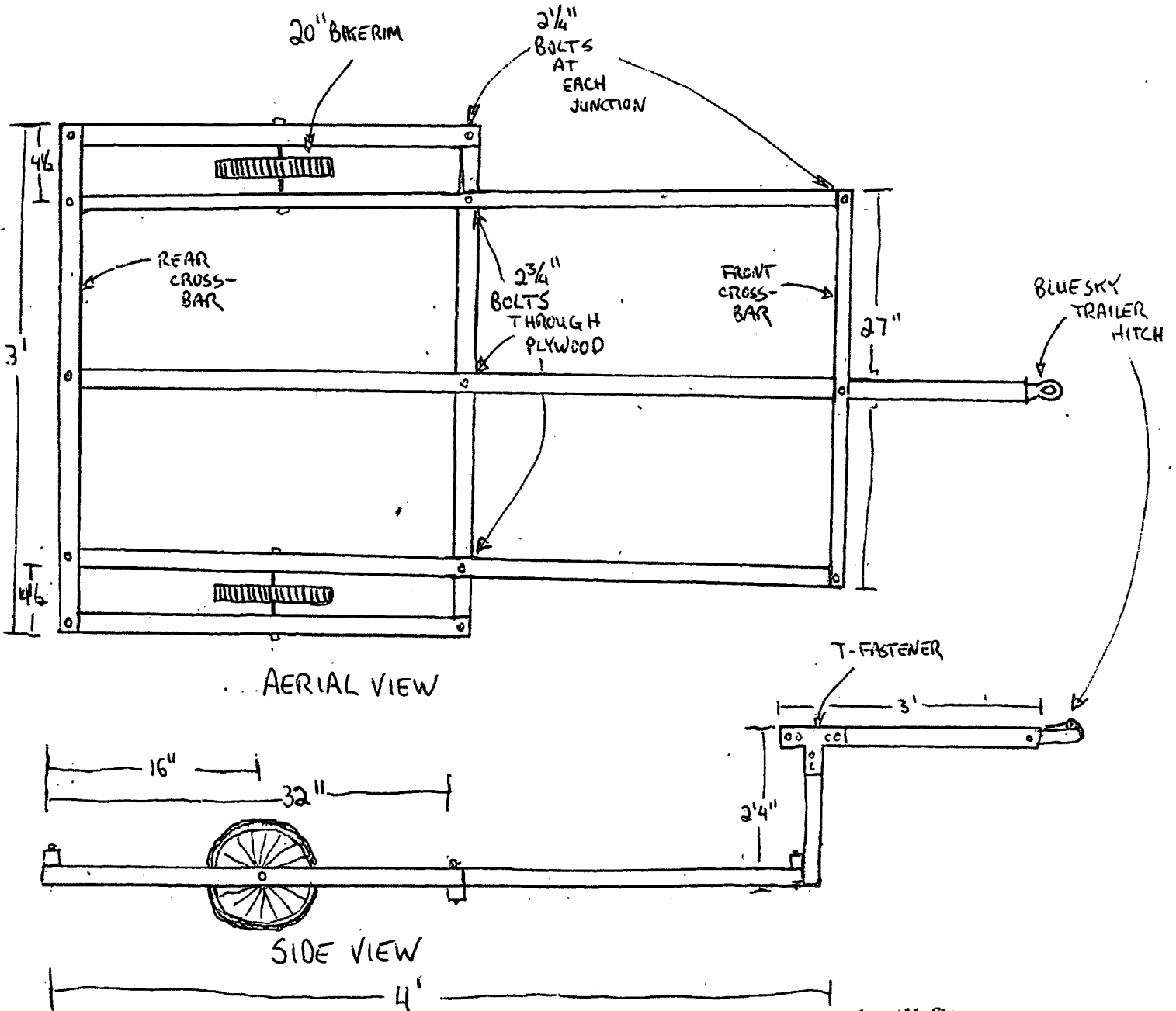

Use rear axles for the wheels — they're longer, and will fit through the steel tubing. Cut a 3/8- or 1/2-inch-thick plywood base, 27 inches wide by 46 inches long for the floor of the cart, attaching it in front of the rear cross-bar and behind the front cross-bar. Bolt it to the frame using the three center bolts.

Does the idea of two-wheeled slides on snow-packed streets keep you from peddling in the winter? You can slow the skids with studded bike tires.

To stud bike tires, find an old knobby tire, a shot bike tube or a roll of always useful duct tape, and thirty or so 3/8-inch self-tapping wood screws, available at hardware stores. Send the screws through the tire from the inside to the outside, going through the knobs of the tire. Space them on each side of the center ridge of the tire, about a half-inch to both sides of center, placing one screw every inch and a half as you work your way around the tire. When you've placed all the screws, line the inside of the tire with the old tube, slit down the middle so it opens up wide enough to cover the inside of the tire, or run a layer or two of duct tape around the inside. Then remount your tire on the rim, and you have it.

### Studded Tire

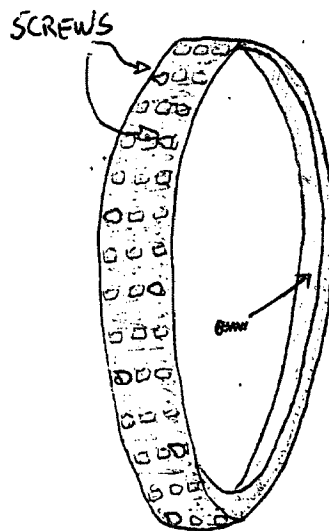



Two warnings: the front tire is the most important to stud — when your back tire slips you can often recover, or at least slide your bike down with some semblance of control. When your front tire goes, so do you. Second, running studded tires on clear pavement sounds like an electric mixer gone haywire. It's most annoying, and it grinds down the screws in no time. If you have an old rim, keep the studded tire mounted on it, and swap back to the regular tire when the streets start to clear. Otherwise, take the time to switch tires.

Give alternative-energy devices a try. You don't have to follow our lead and accumulate piles of parts to reassemble into Rube Goldberg contraptions, although I'd like to see your version if you do. You can work many inexpensive devices into your existing energy systems and save plenty of power in the process.

## AFTERWORD

These articles give a glimpse of what we do at the M.U.D. project. They explain some of the tangible activities on which we spend our time, but not all. I've edited out some of the experiments that we still know too little about to recommend, and a few phenomenal flops.

The articles also give little idea of how we work. We run the M.U.D. project by consensus. We make decisions mutually, so if one of us gets a wild hair about planting turnips in the raspberry patch, we all must agree to allow turnips there before we seed them in. We try to involve everyone here equally in the decisions that affect the project, to make sure the responsibilities and work, and the decision-making power, are divided equally. It sounds happily egalitarian, and it often is. It also makes for frequent, intense meetings, and lots of talk before work gets done.

The longer I practice the consensus skills I'm learning, the more I appreciate them. My frustration at the pace has eased, enough for me to appreciate the clarity offered by working through decisions deliberately.

Consensus also offers me support in taking on M.U.D. project work. Sometimes I question my choices of activities when I work alone — it's often hard to maintain enthusiasm for attaching pieces of salvaged junk together when I'm doing it alone. When I have others who are equally invested in working the project through, my enthusiasm builds.

Consensus also forces me to take responsibility for my choices. I can't cede responsibility to some higher authority — nor can the other participants in the process. We all have to decide for ourselves what is important and why. Beyond that, we need to listen to and work with the feelings and opinions of each other, or we can't make decisions. This eventually results in a more considered decision, first personally and then jointly.

The support and confidence I receive from the consensus process parallels the benefits I receive from other M.U.D. project activities. I've discussed some of our activities here in detail, and I've discussed my political reasons for taking part. What I have yet to discuss are my personal reasons.

The political reasons work their way into my personal reasons for living this way. I want to live in a healthy Missoula Valley, and I want to do my part to make it that way. I climb Mt. Sentinel regularly for the same reason I salvage native plants — I want to keep myself healthy and vigorous, just as I want to keep my surroundings healthy and vigorous. I curse the inversions when they fill our air with grit, just as I feel unpleasantly slothful when I've indulged in too many cookies and haven't found my way up the mountain.

Three years ago a friend wrote an article about the project, published by a national environmental magazine. The last paragraph quoted me describing why I've chosen to work here. He wrote:"I love rummaging around in the soil and pulling up potatoes. It's fun,' he smiled."

The editor of the magazine sent the article to me to check over before she put it in, and I, embarrassed by the quote, deleted it. She put it back in and published it. I'm still embarrassed, but the quote is accurate. I smile when I dig potatoes.

I also enjoy tinkering with solar panels, and I get a thrill out of getting out on my bike the day after a Hellgate wind and hearing the front tire crunch through the snow. I probably smile while I ride, too. And that's why I do it.