

University of Montana

## ScholarWorks at University of Montana

---

Graduate Student Theses, Dissertations, &  
Professional Papers

Graduate School

---

2014

### The Role of NADPH Oxidase in the Modulation of PP2A

Nicole M. Byrnes

*The University of Montana*

Follow this and additional works at: <https://scholarworks.umt.edu/etd>

**Let us know how access to this document benefits you.**

---

#### Recommended Citation

Byrnes, Nicole M., "The Role of NADPH Oxidase in the Modulation of PP2A" (2014). *Graduate Student Theses, Dissertations, & Professional Papers*. 4197.

<https://scholarworks.umt.edu/etd/4197>

This Thesis is brought to you for free and open access by the Graduate School at ScholarWorks at University of Montana. It has been accepted for inclusion in Graduate Student Theses, Dissertations, & Professional Papers by an authorized administrator of ScholarWorks at University of Montana. For more information, please contact [scholarworks@mso.umt.edu](mailto:scholarworks@mso.umt.edu).

THE ROLE OF NADPH OXIDASE IN THE MODULATION OF PP2A

By

Nicole M. Byrnes

B.S. Human Physiology, 2010  
The University of Oregon, Eugene, OR

Thesis

Presented in partial fulfillment of the requirements for the degree of

Master of Science  
in Neuroscience

The University of Montana  
Missoula, MT

February 2014

Approved by:

Sandy Ross, Dean of The Graduate School  
Graduate School

Darrell Jackson, Chair  
Department of Biomedical and Pharmaceutical Sciences

Jesse Hay  
Division of Biological Sciences

Michael Kavanaugh  
Department of Biomedical and Pharmaceutical Sciences

Scott Wetzel  
Division of Biological Sciences

**The Role of NADPH Oxidase in the Modulation of PP2A.**

Chair: Dr. Darrell Jackson

**ABSTRACT**

Transient, but severe global ischemia results in AMPA receptor (AMPA) mediated delayed neuronal death (DND). AMPARs, a major glutamatergic receptor in the CNS, are heteromeric complexes composed of GluA1 - GluA4 subunits. Most AMPARs in the hippocampus are  $\text{Ca}^{2+}$ -impermeable due to the presence of the edited form of the GluA2 subunit. Ischemia results in a down-regulation of GluA2 mRNA and protein expression, resulting in the expression of GluA2-lacking,  $\text{Ca}^{2+}/\text{Zn}^{2+}$ -permeable AMPARs. It has been indicated that these GluA2-lacking AMPARs play a key role in promoting DND following ischemic injury. Recent studies report that an oxidative stress signaling pathway is responsible for the ischemia/reperfusion-induced changes in AMPAR subunit composition. Studies suggest that NADPH oxidase, a superoxide generator, is the source that initiates the oxidative stress-signaling cascade during post-ischemic reperfusion. We observed that inhibition of reactive oxygen species (ROS) generated by mitochondria and xanthine oxidase failed to diminish the oxygen-glucose deprivation/reperfusion (OGD/R)-induced degradation of GluA2. However, inhibition of NADPH oxidase did diminish the OGD/R-induced degradation of GluA2, supporting a role for NADPH oxidase in the oxidative stress-signaling cascade. We also demonstrated that the treatment of acute adult rat hippocampal slices to OGD/R results in the sustained activation of PKC $\alpha$  and sustained Ser880 phosphorylation of GluA2, priming the subunit for internalization. Inhibition of NADPH oxidase resulted in a decrease in activated PKC $\alpha$  and Ser880 phosphorylation of GluA2. The objective of this study was to investigate the role of NADPH oxidase in modulating PKC $\alpha$  activity. PKC $\alpha$  activity is positively regulated by increases in  $\text{Ca}^{2+}$ , therefore any enhancement in  $\text{Ca}^{2+}$  concentrations will increase PKC $\alpha$  activity. Oxidative stress and NADPH oxidase activity have been linked to effecting  $\text{Ca}^{2+}$  levels, therefore, inhibition of NADPH oxidase activity during OGD/R could potentially dampen PKC $\alpha$  activity through the attenuation of oxidative stress-enhanced rises in  $\text{Ca}^{2+}$  entry and intracellular  $\text{Ca}^{2+}$  release necessary for PKC $\alpha$  activation. A second possibility is that PKC $\alpha$  may be redox sensitive and its activity could be increased with oxidative stress. A third possibility is that the phosphatases responsible for regulating PKC $\alpha$  activity may be attenuated by a NADPH oxidase-mediated signaling cascade. Here, we show that protein phosphatase 2A (PP2A), a phosphatase responsible for the dephosphorylation and inactivation of PKC, undergoes a NADPH oxidase-mediated increase in phosphorylation, which has been reported to inactivate the phosphatase. Collectively, these results identify a mechanism that may underlie the post-ischemic-induced degradation of the GluA2 subunit.

## TABLE OF CONTENTS

TITLE	i
ABSTRACT	ii
TABLE OF CONTENTS	iii
LIST OF ABBREVIATIONS	iv
LIST OF DIAGRAMS	v
LIST OF TABLES	vi
LIST OF FIGURES	vii
INTRODUCTION	1
SPECIFIC AIMS	12
MATERIALS AND METHOD	13
RESULTS	16
DISCUSSION	35
IMPACT	37
BIBLIOGRAPHY	41

## **LIST OF ABBREVIATIONS**

ABP - AMPAR binding protein

aCSF - Artificial cerebral spinal fluid

AKAP - A-kinase anchoring protein

AMPA -  $\alpha$ -amino-3-hydroxyl-5-methyl-4-isoxazole-propionate receptor

BDNF - Brain-derived neurotrophic factor

CNS - Central nervous system

DND - Delayed neuronal death

FAD - Flavin adenine dinucleotide

FCCP - Carbonyl cyanide 4-(trifluoromethoxy)phenylhydrazone

GluA1 - Glutamate receptor subunit, 1

GluA2 - Glutamate receptor subunit, 2

GRIP1 - Glutamate receptor interacting protein 1

IRI - Ischemic/reperfusion injury

LTP/LTD - Long term potentiation/depression

NADPH Oxidase - Nicotinamide adenine dinucleotide phosphate-oxidase

NBT - nitroblue tetrazolium

NMDAR - N-methyl-D-aspartate receptor

NOX - NADPH Oxidase

NT-3 - Neurotrophin-3

OGD/R - Oxygen-glucose deprivation/reperfusion

PICK1 - Protein interacting with C kinase 1

PKC - Protein kinase C

PP1 - Protein phosphatase 1

PP2A - Protein phosphatase 2A

ROS - Reactive oxygen species

rtPA - Recombinant tissue plasminogen activator

SDS-PAGE - Sodium dodecyl sulfate polyacrylamide gel electrophoresis

SFK - Src family kinase

## LIST OF DIAGRAMS

<b>Diagram 1:</b>	Calcium permeability of AMPARs	2
<b>Diagram 2:</b>	The PKC family	4
<b>Diagram 3:</b>	Model for the regulation of AMPAR internalization by GluA2 C-terminal phosphorylation and GRIP1/ABP and PICK1 interaction	5
<b>Diagram 4:</b>	Structure of PP2A	6
<b>Diagram 5:</b>	Structure of the core region of NADPH oxidase (NOX) enzymes	11

## LIST OF TABLES

<b>Table 1:</b>	Expression of NOX enzymes in CNS regions	10
<b>Table 2:</b>	Reasons for translational failure of neuroprotective agents from pre-clinical to clinical studies	38

## LIST OF FIGURES

<b>Figure 1:</b>	GluA2 is selectively degraded following OGD/R exposure	17
<b>Figure 2:</b>	NADPH oxidase activity contributes to reactive oxygen species generation during reperfusion	19
<b>Figure 3:</b>	Inhibition of NADPH oxidase attenuates the OGD/R-induced loss of GluA2	22
<b>Figure 4:</b>	Inhibition of mitochondrial and xanthine oxidase ROS generation fails to rescue the OGD/R-induced loss of GluA2	24
<b>Figure 5:</b>	The OGD/R-induced increase in Ser880 phosphorylation of GluA2 is blunted with inhibition of NADPH oxidase	26
<b>Figure 6:</b>	The OGD/R-induced increase in activated PKC $\alpha$ associated with PICK1 is blunted with inhibition of NADPH oxidase	29
<b>Figure 7:</b>	PP2A undergoes Tyr307 phosphorylation following OGD/R exposure	31
<b>Figure 8:</b>	Inhibition of NADPH oxidase attenuates the OGD/R-induced increase in PP2A Tyr307 phosphorylation	33



## **INTRODUCTION**

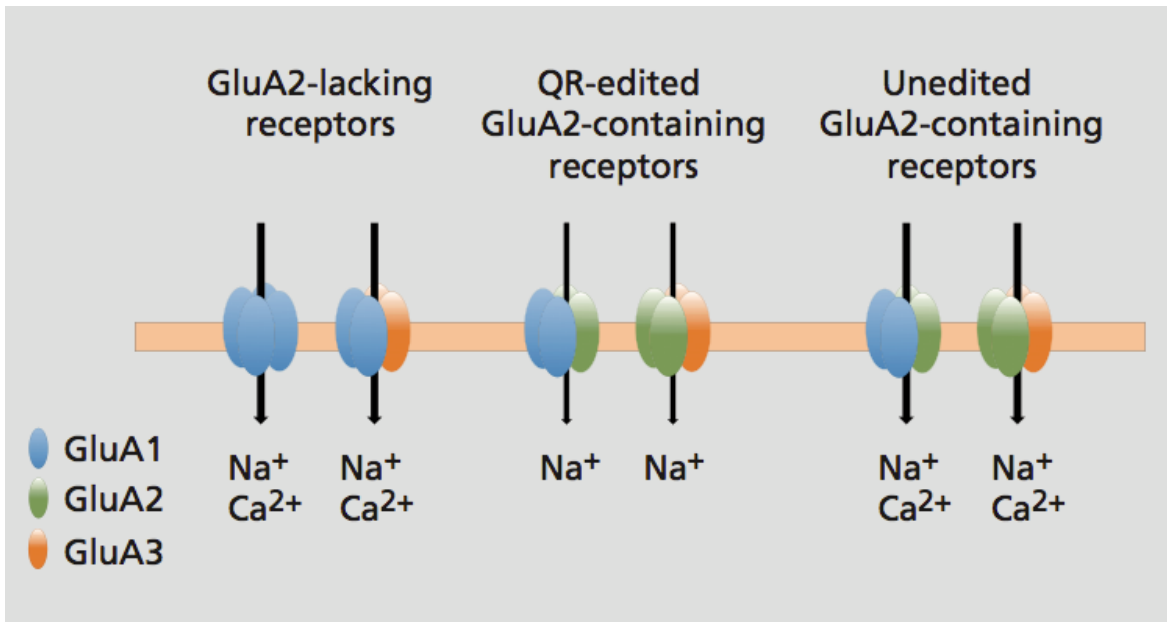
### **AMPARs**

In the CNS, AMPARs mediate the majority of fast excitatory synaptic transmission and play a crucial role in synaptic plasticity and synaptogenesis.<sup>1,2</sup> These ionotropic glutamatergic receptors are tetrameric complexes of four subunits GluA1-GluA4, encoded by distinct, differentially expressed genes.<sup>2-5</sup> All AMPAR subunits contain an extracellular domain, three transmembrane domains, a re-entry loop (that forms the wall of the ion permeable pore), and an intracellular domain.<sup>4,5</sup> Most AMPARs expressed in the CNS are GluA2 containing heteromers. This subunit is fundamental in determining AMPAR function. Many biophysical characteristics are determined by the GluA2 subunit including receptor kinetics, single-channel conductance, and  $\text{Ca}^{2+}$  permeability. AMPARs containing the edited form of GluA2 (Q607R) are impermeable to  $\text{Ca}^{2+}/\text{Zn}^{2+}$  entry. AMPARs that lack GluA2 or contain the unedited GluA2(Q607) are permeable to divalent cations such as  $\text{Ca}^{2+}/\text{Zn}^{2+}$  (Diagram 1).<sup>3,6</sup> Transgenic mouse strains that lack GluA2 or editing of this subunit display profound adverse phenotypes in development, behavior and synaptic function, thus supporting the critical role of GluA2 and its regulation in AMPAR and brain function.<sup>7,8</sup> Furthermore, a number of neurological disorders, including cerebral ischemia, ALS, pain, and epilepsy are associated with the disruption of GluA2 function.<sup>9</sup> Changes in the expression of  $\text{Ca}^{2+}$ -permeable AMPARs can alter  $\text{Ca}^{2+}$ -dependent signaling cascades, synaptic properties, or lead to damage of vulnerable neurons and glial cells.<sup>10</sup>

### **Kinases & Phosphatases**

Phosphorylation is critical for signal transduction and the regulation of a variety of physiological processes. Furthermore, a number of diseases are connected to a dysregulation of phosphorylation signaling pathways. AMPAR function is mediated in part by changes in phosphorylation state, which is regulated by a dynamic balance between protein kinase and protein phosphatase activity.<sup>11</sup>

PKC is a family of serine/threonine  $\text{Ca}^{2+}$ -dependent kinases. PKC is present in high concentrations in neuronal tissue and plays a role in a number of neuronal functions including synaptic plasticity.<sup>12</sup> The general structure of PKC consists of a C-terminal catalytic domain and a N-terminal regulatory domain, all PKC family members contain a phosphatidylserine (PS)

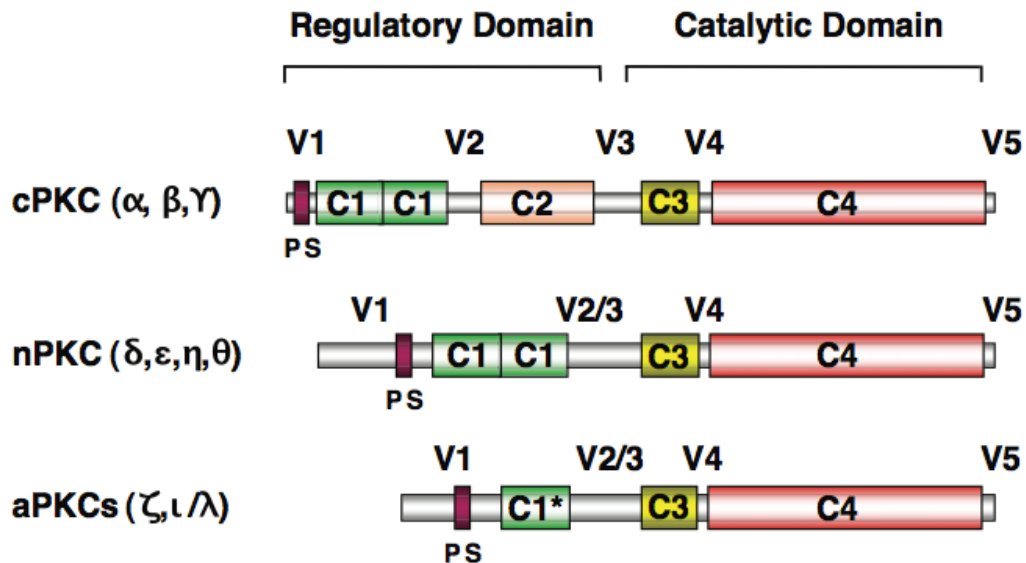


**Diagram 1. Calcium permeability of AMPARs.** RNA editing of the GluA2 subunit determines calcium permeability of AMPARs. AMPARs lacking the GluA2 subunit, or an unedited GluA2 subunit are Ca<sup>2+</sup>-permeable. Receptors containing the edited form of GluA2 are Ca<sup>2+</sup>-impermeable.<sup>3</sup>

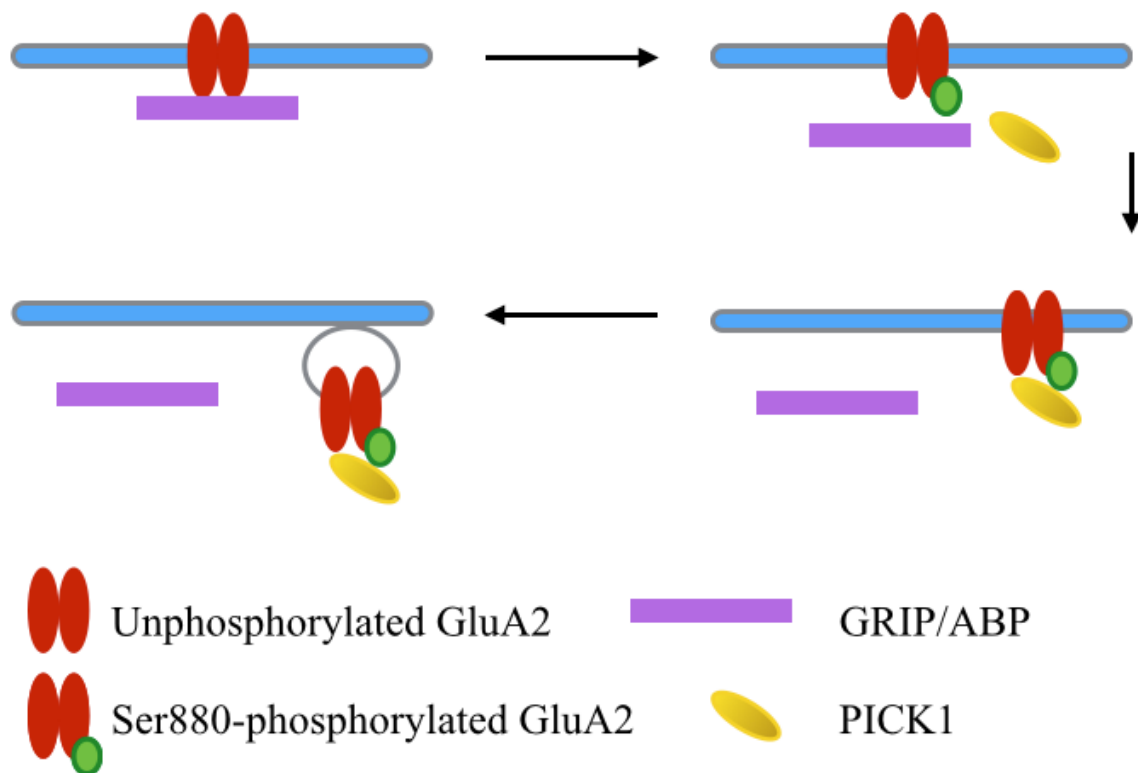
binding domain for membrane interaction (Diagram 2).<sup>13-15</sup> The activation of PKC typically involves its translocation from the cytosol to specific binding domains at cell membranes. The activity of PKC is regulated by its compartmentalization within the cell, specific anchoring proteins help localize PKC to its sites of action.<sup>14</sup> AKAPs are signal-organizing, multivalent anchoring proteins that can target entire signaling complexes to specific substrates. AKAPs often form complexes that include enzymes for both signal transduction and signal termination, which generates a locus to regulate the forward and backward steps in a given signaling process. PKC is a component of the AKAP79/150 signaling complex. AKAP79/150 is enriched in the postsynaptic-density fractions of neuronal lysates and is present in the dendritic spines of neurons. Studies have shown that the AKAP79/150 signaling complex controls the phosphorylation status and facilitates the regulation of various ion channels including AMPARs, NMDARs, and L-type Ca<sup>2+</sup> channels. PKC is also a component of the following AKAP signaling complexes: AKAP350, Gravin, AKAP-Lbc, and Pericentrin.<sup>16</sup>

Activated PKC $\alpha$  phosphorylates amino acid residue Ser880 of GluA2 which alters AMPAR functions, one of which is receptor internalization.<sup>12,17-19</sup> Phosphorylation of Ser880, within the GluA2 PDZ-binding site, by PKC $\alpha$  decreases the affinity of GluA2 for synaptic anchoring proteins GRIP1 and ABP, thus enabling the interaction of PICK1 with GluA2 (Diagram 3). In both cerebellar Purkinje and hippocampal neurons this promotes the internalization of AMPARs and decreases GluA2-containing surface receptors.<sup>20-22</sup> Dephosphorylation of PKC is regulated by the protein phosphatase PP2A.<sup>23,24</sup>

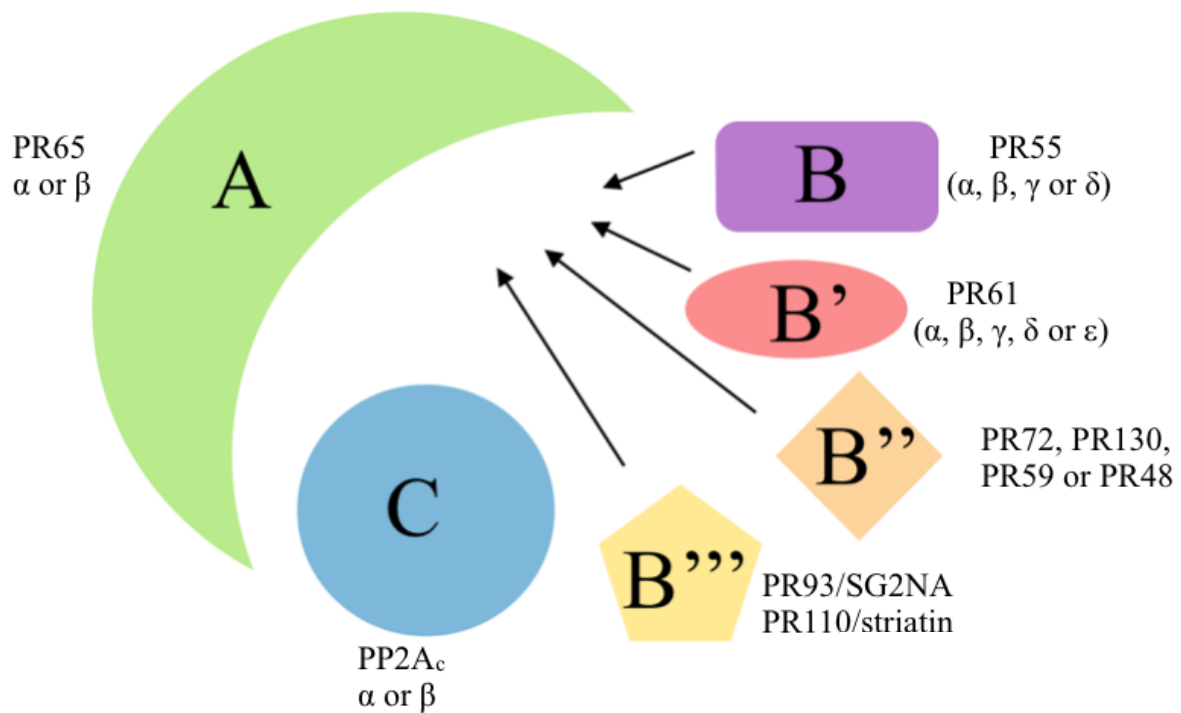
PP2A is an important serine/threonine phosphatase involved in many aspects of cellular function including cell-cycle regulation, cell proliferation and death, development, cell mobility, and regulation of multiple signal transduction pathways.<sup>25,26</sup> The PP2A system contains two components, the core enzyme and the holoenzyme. A scaffolding protein (A subunit) and a catalytic subunit (C subunit), make up the PP2A core enzyme. The PP2A core enzyme interacts with a variable regulatory subunit (B subunit) to form the fully active heterotrimeric holoenzyme (Diagram 4). The expression level of the various regulatory subunits are diverse depending on cell types and tissue. Therefore, the B subunits determine the substrate specificity and spatial and temporal functions of PP2A.<sup>25-28</sup> Actions of phosphatases modulate signaling in a highly specific



**Diagram 2. The PKC family.** PKC isoforms contain constant regions (C1–4) and variable regions (V1–5) and can be divided into three subgroups. cPKCs (classic) are activated in the presence of calcium, which binds to the C2 domain, and DAG, which binds to the C1 domains. nPKCs (novel) lack C2 domains and are  $\text{Ca}^{2+}$ -independent but still require DAG for full activation. aPKCs (atypical) possess only one nonfunctional C1 domain (C1\*) and no C2 domain and are both  $\text{Ca}^{2+}$ - and DAG-independent. The C3 regions (ATP-binding) and C4 regions (protein substrate binding) are highly conserved between isoforms. In each case, the pseudosubstrate (PS) sequences, found in the V1 variable region, interfere with the catalytic domains to inhibit substrate phosphorylation until conformational changes induced by activators allow full activation.<sup>15</sup>



**Diagram 3. Model for the regulation of AMPAR internalization by GluA2 C-terminal phosphorylation and GRIP1/ABP and PICK1 interaction.** In the basal state, AMPARs containing GluA2 subunits at the postsynaptic membrane are stable through their interaction with GRIP1/ABP. Phosphorylation of GluA2 at Ser880 by PKC $\alpha$ , results in the disruption of the interaction of GluA2 with GRIP1/ABP, enabling AMPARs to interact with PICK1 and internalize.<sup>19</sup>



**Diagram 4. Structure of PP2A.** C is the catalytic subunit, A is the second regulatory or structural subunit, and B/B'/B''/B''' are the third variable subunits, which are structurally unrelated. In mammalia, A and C are encoded by two genes ( $\alpha$  and  $\beta$ ); the B/PR55 subunits are encoded by four related genes ( $\alpha$ ,  $\beta$ ,  $\gamma$  and  $\delta$ ); the B'/PR61 family are encoded by five related genes ( $\alpha$ ,  $\beta$ ,  $\gamma$ ,  $\delta$  and  $\epsilon$ ), some of which give rise to alternatively spliced products; the B'' family probably contains three related genes, encoding PR48, PR59 and the splice variants PR72 and PR130; SG2NA and striatin comprise the B''' subunit family.<sup>28</sup>

and regulated manner. Mechanisms for the regulation of the activity of PP2A in neurons include protein-protein interactions, subcellular compartmentalization, and inhibition.<sup>29</sup> PP2A undergoes inactivation upon phosphorylation at Tyr307.<sup>30</sup>

### **Ca<sup>2+</sup>-permeable AMPARs in Neuronal Death**

A balance in activity of protein kinases and phosphatases is required for the regulation of protein phosphorylation.<sup>30</sup> Ca<sup>2+</sup>-permeable AMPARs are regulated by phosphorylation. Although Ca<sup>2+</sup>-permeable AMPARs are critical for synaptic plasticity, they are also associated with several neurological disorders. Global ischemia during cardiac arrest impacts 150,000 Americans annually and frequently results in the delayed onset of neurological deficits. Transient but severe global ischemia triggers selective and delayed neuronal death.<sup>2</sup> Hippocampal pyramidal neurons in the CA1 region are especially vulnerable. Numerous studies indicate that Ca<sup>2+</sup>/Zn<sup>2+</sup>-permeable AMPARs are involved in this delayed neuronal death.<sup>31-34</sup> Most AMPARs expressed on adult hippocampal pyramidal neurons, including the CA1 region, contain the edited form of GluA2 (Q607R), and are thus impermeable to Ca<sup>2+</sup>/Zn<sup>2+</sup> entry. AMPARs undergo a subunit rearrangement following ischemic injury, switching from GluA2-containing Ca<sup>2+</sup>/Zn<sup>2+</sup>-impermeable AMPARs to GluA2-lacking Ca<sup>2+</sup>/Zn<sup>2+</sup>-permeable AMPARs. Ischemia triggers the down regulation of GluA2 protein expression and mRNA and increased AMPAR-mediated Ca<sup>2+</sup>/Zn<sup>2+</sup> influx in CA1 neurons.<sup>2, 31-33</sup> Substantial evidence demonstrates the expression of functional GluA2-lacking Ca<sup>2+</sup>/Zn<sup>2+</sup>-permeable AMPARs in CA1 neurons 24-48 hours post-ischemia.<sup>35-37</sup> Although considerable evidence exists for alterations in AMPAR subunit composition and function hours or days after injury, the underlying mechanism mediating the subunit switch remains unclear.

### **NADPH Oxidase and Reactive Oxygen Species**

During IRI, tissue damage, which is frequently irreversible, can occur in three phases. The ischemic phase of IRI constitutes the disruption of blood flow resulting in a lack of oxygen and nutrients.<sup>38,39</sup> Characteristics of this phase include altered cell metabolism, calcium overload, and apoptotic and necrotic cell death. During the second or reinstatement phase, blood flow is restored. The reintroduction of oxygen is critical for survival, however because oxygen can be converted to ROS, replenishment can also be damaging. ROS can damage cells directly and

indirectly through a variety of mechanisms.<sup>40,41</sup> Paradoxically, during the third or post-reperfusion phase, ROS promote conditions for survival by impacting highly regulated processes including angiogenesis.<sup>42</sup>

IRI is mediated, in part, by the production of superoxide and other ROS.<sup>43</sup> Mitochondria and xanthine oxidase are two sources of ROS responsible for producing superoxide during the ischemic phase. An initial burst of ROS is generated by mitochondria in response to ischemia, but halted upon mitochondrial depolarization. The second phase of ROS is generated by the activation of xanthine oxidase. Physiologically, xanthine oxidase participates in a variety of biochemical reactions including the hydroxylation of various purines, pterins, and aromatic heterocycles, thereby contributing to the detoxification or activation of endogenous compounds and xenobiotics. During ischemia, transmembrane ion gradients are dissipated, allowing cytosolic concentrations of calcium to rise, ultimately converting xanthine dehydrogenase to xanthine oxidase.<sup>44</sup> Concurrently, depletion of intracellular ATP leads to the conversion of adenine nucleotides to hypoxanthine and xanthine, substrates for xanthine oxidase. NADPH oxidase is responsible for the generation of ROS during reperfusion.<sup>45</sup> Generally, ROS sources generate ROS as a byproduct of metabolism or during pathologic conditions. However, the NOX family NADPH oxidases are the exception. Superoxide produced by neuronal NADPH oxidase is thought to function in LTP and intracellular signaling.<sup>46-48</sup> Although intracellular redox signaling, in part due to NADPH oxidase function, is important for LTP and memory, excessive oxidative stress can impair cellular processes and lead to neuronal death. Although superoxide was once considered a neurotoxic molecule, a growing body of evidence suggests that ROS, such as superoxide, are necessary to induce the expression of LTP in the CA1. Cell-permeable superoxide scavengers have been shown to prevent the induction of LTP and transgenic mice that overexpress the superoxide-scavenging enzyme SOD1, exhibit impaired LTP.<sup>49</sup> Normal neuronal function depends on a carefully regulated redox environment.<sup>50</sup>

NADPH oxidases are transmembrane multiprotein complexes, first identified in phagocytes, that generate superoxide by catalyzing the electron transport from NADPH to molecular oxygen.<sup>42,51</sup> Seven NOX genes have been identified: NOX1 to 5 and DUOX1 and 2.

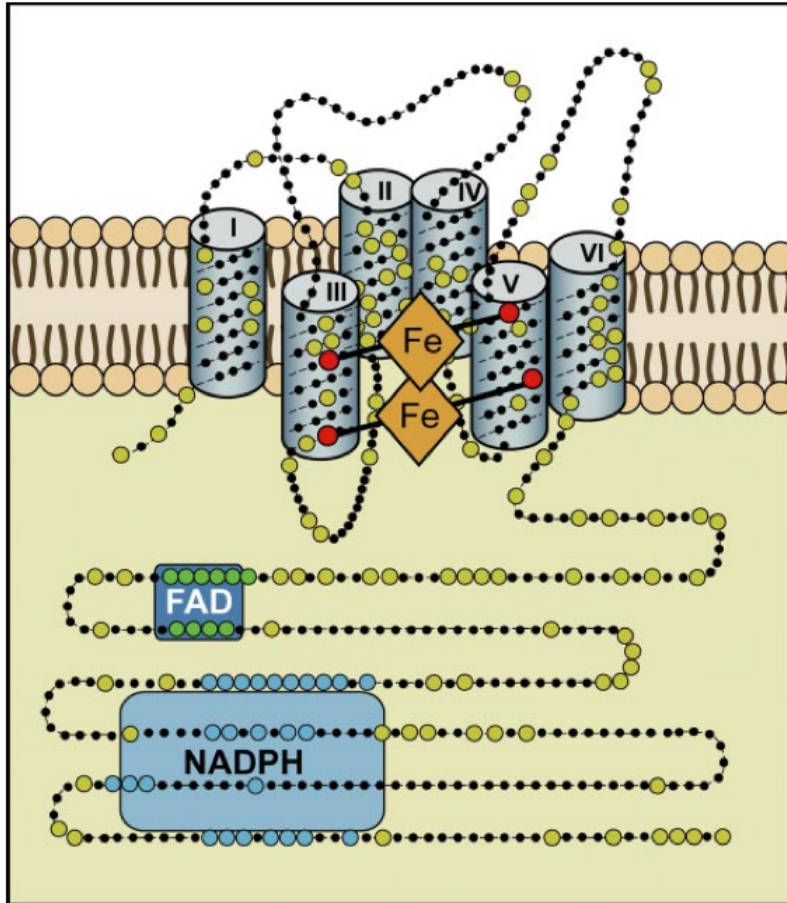


The NOX enzymes are widely distributed in a variety of tissues. NOX1, NOX2, NOX3, and NOX4 transcripts have been identified in the CNS (Table 1).<sup>52</sup> The NOX family has a number of conserved structural properties; an NADPH-binding site, a FAD-binding site, six transmembrane domains, and four heme-binding histidines (Diagram 5).<sup>53</sup> NADPH oxidase derived ROS have both physiological and pathological roles.<sup>53</sup> Following ischemia, superoxide is generated by NADPH oxidase during the reintroduction of oxygen, leading to oxidative stress and neuronal death.<sup>43</sup> Compelling evidence supports the post-ischemic contribution of NADPH oxidase generated ROS in oxidative stress and neuronal death. Following ischemic lung or brain injury, NOX2 KO and p47<sup>phox</sup> KO mice presented less oxidative injury (lipid peroxidation, protein nitration, and oxidative DNA damage) as compared to WT mice.<sup>54-56</sup> Neurotrophins such as BDNF and NT-3 promote growth and survival in neurons including cultured cortical neurons. However, in mature cortical cultures, these neurotrophins paradoxically potentiate neuronal necrosis induced by excitotoxins, oxidants or OGD. Prolonged exposure to the neurotrophin BDNF, activates NADPH oxidase and induces neuronal necrosis in cortical cultures. Administration of the NADPH oxidase inhibitor, AEBSF, attenuated increases in oxygen free radicals and significantly attenuated BDNF induced neuronal death.<sup>57</sup>

**Table 1. Expression of NOX Enzymes in CNS Regions.**<sup>52</sup>

<i>NOX isoforms</i>	<i>CNS area localization</i>	<i>Species</i>	
<b>NOX1</b>	Adult total brain	M	
	Cortex	R	
	Cerebellum of pups after prolonged gestational exposure to ethanol	R	
	Temporal lobe, hypothalamus, cerebellum of adult rats after ethanol administration	R	
	Dorsal root ganglion	M, R	
	Hypothalamic paraventricular nucleus	R	
	<b>NOX2</b>	Adult total brain	M
Corpus callosum		H	
Spinal cord		H	
Spinal cord slices in culture		R	
Hippocampus		H, M, R	
Cortex		M, R	
Brainstem		M	
Amygdala		M	
Striatum		M, R	
Thalamus		M	
Cerebellum		M, R	
Dorsomedial nucleus tractus solitarius		R	
Posterior hypothalamic nuclei		R	
Hypothalamic paraventricular nucleus		R	
Locus coeruleus		R	
Medulla		H	
Rostral ventrolateral medulla		R, Rab	
Dorsal root ganglion		M, R	
<b>NOX3</b>		Adult brain	R
		Cerebellum of pups after prolonged gestational exposure to ethanol	R
	Temporal lobe, hypothalamus, cerebellum of adult rats after ethanol administration	R	
	<b>NOX4</b>	Adult total brain	H, M
Cortex		M	
Hippocampus (Ammon's horn)		M	
Cerebellum		M	
Dorsal root ganglion		M	
Hypothalamic paraventricular nucleus		R	
<b>Subunits</b>		p47 <sup>phox</sup> , p67 <sup>phox</sup>	Medulla, hypothalamus, pons
	p47 <sup>phox</sup>	Rostral ventrolateral medulla	

H, human; M, mouse; R, rat; Rab, rabbit.



**Diagram 5. Proposed structure of the core region of NADPH oxidase (NOX) enzymes.**

All NOX family members share six highly conserved transmembrane domains. Transmembrane domains III and V each contain two histidines, spanning two asymmetrical hemes. The cytoplasmic COOH terminus contains conserved flavin adenine dinucleotide (FAD) and NADPH binding domains. NOX enzymes are thought to be single electron transporters, passing electrons from NADPH to FAD, to the first heme, to the second heme, and finally to oxygen. Enlarged circles represent amino acids that are conserved through human NOX1, NOX2, NOX3, and NOX4.<sup>53</sup>

## **SPECIFIC AIMS**

We hypothesize that increased activity of NADPH oxidase during reperfusion results in the sustained phosphorylation of GluA2, due to phosphatase inactivation, and ultimately leads to GluA2 degradation.

**Specific Aim 1: To determine if the post-ischemic induced degradation of GluA2 is NADPH oxidase-dependent or caused by other ROS generators.**

Treat adult rat hippocampal slices with the xanthine oxidase inhibitor oxypurinol and the mitochondrial uncoupler FCCP and perform an OGD/R time course to determine if these ROS generators are involved in the decrease in GluA2 protein levels.

**Specific Aim 2: To test the hypothesis that the sustained GluA2 phosphorylation involves NADPH oxidase-mediated inactivation of phosphatases that regulate GluA2 phosphorylation.**

**Sub Aim 2.1: To identify phosphatases the undergo OGD/R-induced inactivation.**

Perform an OGD/R time course to determine if phosphatases undergoes inactivation via increased phosphorylation.

**Sub Aim 2.2: To determine whether inhibition of NADPH oxidase attenuates phosphatase inactivation.**

Treat slices with apocynin to determine if the OGD/R-induced phosphorylation is mediated by NADPH oxidase.

## **MATERIALS & METHODS**

### **Preparation of acute hippocampal slice:**

Adult male (6-8 week) Sprague-Dawley rats (Charles River Labs, Wilmington, MA, USA; Harlan, Livermore, CA, USA) were anesthetized with isoflurane and quickly decapitated. The brain was rapidly removed and submerged into ice-cold cutting solution (75 mM Sucrose, 80 mM NaCl, 2.5 mM KCl, 1.25 mM NaH<sub>2</sub>PO<sub>4</sub>, 24 mM NaHCO<sub>3</sub>, 25 mM Glucose, 4 mM MgCl<sub>2</sub>, 1 mM L-Ascorbic Acid, 3 mM Na Pyruvate, 0.5 mM CaCl<sub>2</sub>, pH 7.4). 400-micron coronal slices were made from the dissected hippocampi using a McIlwain tissue chopper (Vibratome, St. Louis, MO, USA). Slices were equilibrated for 60-90 minutes prior to OGD/R in oxygenated (95% O<sub>2</sub>, 5% CO<sub>2</sub>) aCSF (124 mM NaCl, 2.5 mM KCl, 1.25 mM KH<sub>2</sub>PO<sub>4</sub>, 26 mM NaHCO<sub>3</sub>, 10 mM Glucose, 1.5 mM MgCl<sub>2</sub>, 2.5 mM CaCl<sub>2</sub>, pH 7.4) at 33°C. Slices were transferred into fresh aCSF halfway through the equilibration period. During the final 30 minutes of equilibration slices were pre-treated with 30 µM apocynin (Sigma, St. Louis, MO, USA), 20 µM oxypurinol (Sigma, St. Louis, MO, USA), 0.5 µM FCCP (Sigma, St. Louis, MO, USA) or 1:1000 DMSO (vehicle), the treatments remained present throughout the duration of the experiment.

### **Oxygen-glucose deprivation/reperfusion of hippocampal slices:**

After equilibration, slices to be subjected to OGD/R were rinsed with glucose-free aCSF (aCSF with 10 mM mannitol substituted for 10 mM glucose, pH 7.4), and incubated in glucose-free aCSF for 40 minutes in a hypoxic glove box (Coy Laboratories, Grass Lake, MI, USA) with a gas mixture consisting of 95% N<sub>2</sub> and 5% CO<sub>2</sub>. To ensure complete anoxia of the glucose-free aCSF it was placed in the glove box (0% O<sub>2</sub>) overnight. Post OGD, the slices were transferred from the hypoxic glove box into oxygenated glucose-containing aCSF. The normoxic controls remained in glucose-containing aCSF for the duration of the experiment and were time-matched to the last reperfusion time point.

### **Nitro-blue tetrazolium assay:**

Slices were equilibrated in aCSF as previously indicated. After equilibration, slices were incubated in oxygenated aCSF with nitro-blue tetrazolium chloride (NBT; 0.5 mg/mL; Sigma, St. Louis, MO, USA) for 10 minutes before OGD/R treatment. Excess NBT was then rinsed away with glucose-free aCSF and OGD/R treatment was performed as previously described. At

the indicated time points, the reaction was stopped with 0.25 M HCl. Slices were visualized via phase contrast microscopy (Olympus SZX16, 4X air objective), then lysed by sonication in DMSO containing a protease inhibitor cocktail. 200  $\mu$ l of lysates were aliquoted into a 96 well plate and absorbance was read at 550 nm on a spectrophotometric microplate reader (VersaMax plate reader, Molecular Devices, Sunnyvale, CA, USA). Normoxic controls were rinsed with glucose-containing aCSF after NBT incubation and left in glucose-containing aCSF to be time-matched to the last of the OGD/R time points before being processed the same as OGD/R-treated slices.

### **Lysate Preparation:**

At the designated time points slices were transferred from the aCSF and rinsed in ice-cold PBS (pH 7.4). Slices were subsequently transferred into eppendorf tubes containing lysis buffer (50 mM Tris, 150 mM NaCl, 1 mM EDTA, 1 mM PMSF, 1% NP-40, 1% protease and phosphatase inhibitor cocktail (Thermo, Rockland, IL, USA), pH 7.4) and lysed promptly through sonication for 3 separate 5 second bursts at 40% power output with a VirTis Ultrasonic Cell Disrupter 100 (Gardiner, NY, USA). Lysates were centrifuged at 1,000 x g to remove cellular debris and nuclei. A bicinchoninic acid assay (Thermo, Rockland, IL, USA) was utilized to determine protein content. Samples were denatured in Laemmli buffer and heat (10 minutes, 100°C), resolved via SDS-PAGE, and transferred onto a nitrocellulose membrane (Bio-Rad, Berkeley, CA, USA) for immunoblotting.

### **Immunoblotting:**

Blots were blocked with either 5% non-fat dry milk or 5% BSA (for phospho-antibody detection) in Tris Buffered Saline, 0.1% Tween 20, pH 7.5, for 1 hour at room temperature. Blots were then incubated with primary antibody at 4°C overnight. The affinity purified rabbit-monoclonal GluA2 (1:1000), phospho-GluA2 (Ser880) (1:1000), PP2A (1:1000), phospho-PP2A (Tyr307) (1:1000), PKC $\alpha$  (1:2000), and phospho-Protein Kinase C  $\alpha$  (Thr497) (1:2000) antibodies were purchased from Epitomics (Burlingame, CA, USA). The affinity purified goat polyclonal PICK1 (1:50) antibody was purchase from Santa Cruz Biotechnologies (Santa Cruz, CA, USA). The affinity purified GluA1 rabbit-polyclonal antibody (1:1000) was purchased from abcam (Cambridge, MA, USA). Goat anti-Mouse-HRP and Goat-anti-Rabbit-HRP secondary antibodies

(1:2000) were purchased from Jackson ImmunoResearch (West Grove, PA, USA).

Immunoreactive bands were visualized with a Fuji imaging system using enhanced chemiluminescence. Bands were analyzed using Fuji Image-Gauge software.

### **Immunoprecipitation:**

To visualize the PICK1-PKC $\alpha$  protein complex, rat hippocampal slices were lysed in a buffer containing 50 mM Tris-HCl, 150 mM NaCl, 1 mM EDTA, 1 mM phenylmethylsulfonyl fluoride, 1% NP-40, and 1% protease and phosphatase inhibitor cocktail, pH = 7.5. Protein concentration was then determined using a BCA assay, and lysates (500  $\mu$ g/sample in 500  $\mu$ l) were then pre-cleared using Protein-A/G 50/50 mix of agarose beads for 1 hour at 4°C followed by incubation with PICK1 (1:50) antibody overnight at 4°C. The immunocomplex was then incubated for 4 hours with 50  $\mu$ L Protein-A/G beads at 4°C with rotation before being washed 3 times with lysis buffer. Samples were then eluted from the agarose beads by treatment with Laemmli buffer and heat (100°C) and subjected to 7.5% SDS-PAGE. After transfer to nitrocellulose membranes, blots were blocked as and incubated overnight at 4°C as previously described. Immunoreactive bands were analyzed using Fuji Image-Gauge software.

### **Statistical Analysis:**

ANOVA (with post hoc Bonferroni test) was used to determine significance. Statistical tests were performed using GraphPad Prism Software (La Jolla, CA, USA).

## **RESULTS**

### **OGD/R induces the selective degradation of GluA2.**

Numerous studies have demonstrated that ischemia/reperfusion results in an alteration of the subunit composition of AMPARs, from those containing the edited form of GluA2 to those lacking the edited GluA2 subunit, an event known to contribute to AMPAR-mediated cell death.<sup>2,5,32,33</sup> In collaboration with Phil Beske, we set out to identify mechanisms contributing to the OGD/R mediated changes in GluA2. Initial experiments were performed to determine whether total GluA1 and GluA2 protein levels were decreased in slices subjected to OGD/R. While GluA1 total protein levels were not significantly altered, GluA2 levels were significantly decreased in slices subjected to OGD followed by 30 and 60 minutes of reperfusion (Fig. 1). These results indicate that OGD/R promotes the selective degradation of GluA2.

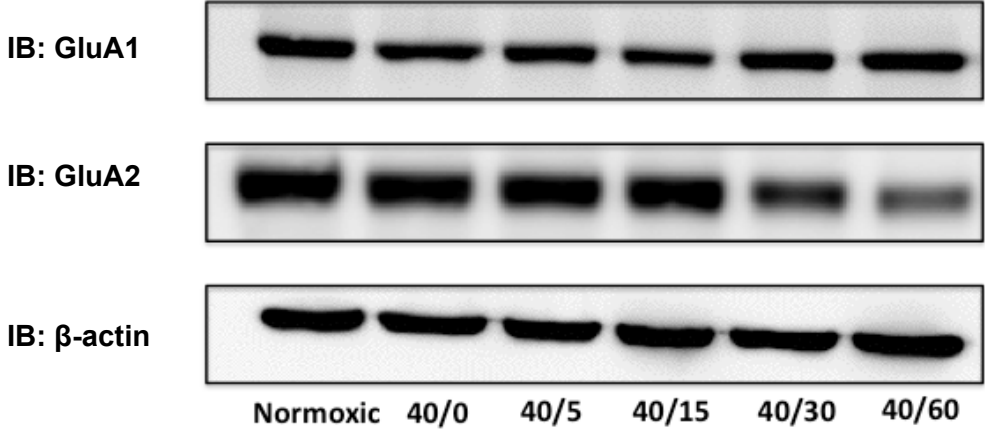
### **NADPH oxidase contributes to ROS generation in the adult rat hippocampus following exposure to OGD/R.**

Recent studies indicate that an oxidative stress-signaling pathway is responsible for the OGD/R-induced changes in AMPAR subunit composition. Studies suggest that NADPH oxidase, a superoxide generator, is the source that initiates the oxidative stress-signaling cascade during post-ischemic reperfusion. To examine NADPH oxidase-dependent ROS generation in slices subjected to OGD/R, a NBT assay was performed in the presence or absence of the NADPH oxidase inhibitor apocynin (30  $\mu$ M). NBT is reduced by superoxide or oxidant metabolites to form formazan, an insoluble dye that can be observed via colorimetry. Exposure of hippocampal slices to OGD/R increased formazan formation, demonstrating a large increase in ROS generation, particularly during the reperfusion of slices subjected to OGD (Fig. 2). Results from a previous report indicate that OGD/R results in a tri-phasic production of ROS due to mitochondria, xanthine oxidase and NADPH oxidase. NADPH oxidase is responsible for the burst of ROS seen during reperfusion.<sup>45</sup> Treatment of slices subjected to OGD with the NADPH oxidase inhibitor apocynin significantly attenuated the ROS generation observed during reperfusion (Fig. 2). Our data indicates that NADPH oxidase serves as a key generator of ROS production during reperfusion of OGD-subjected hippocampal slices.

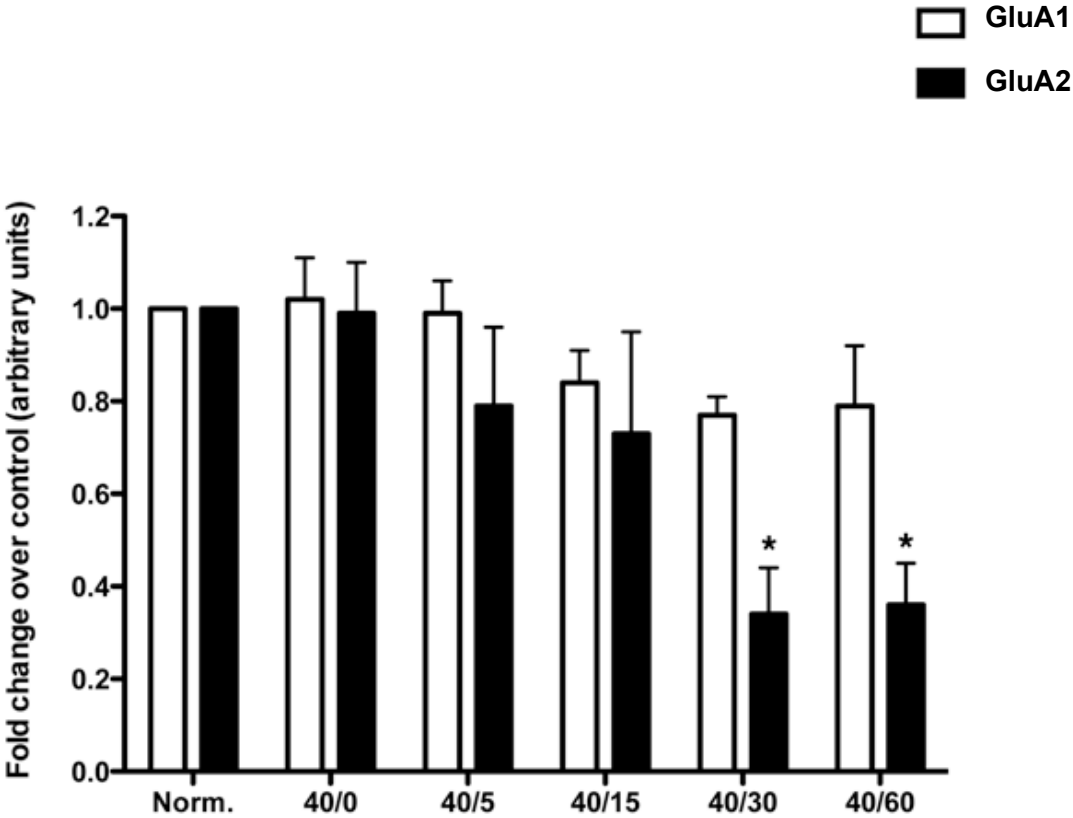


Figure 1.

A.



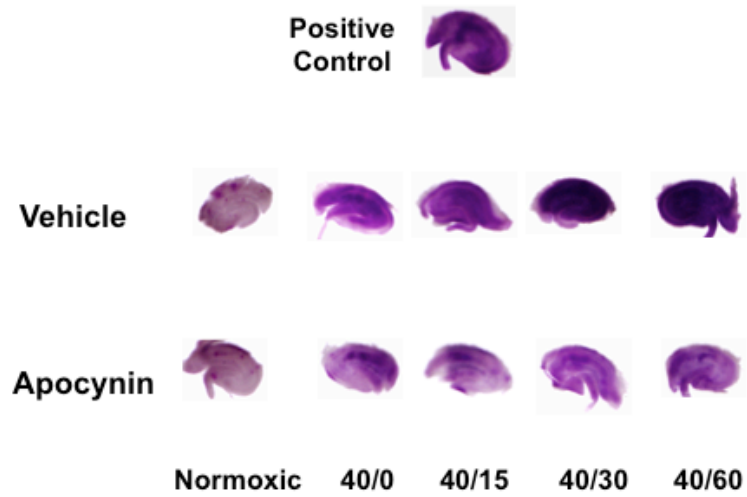
B.



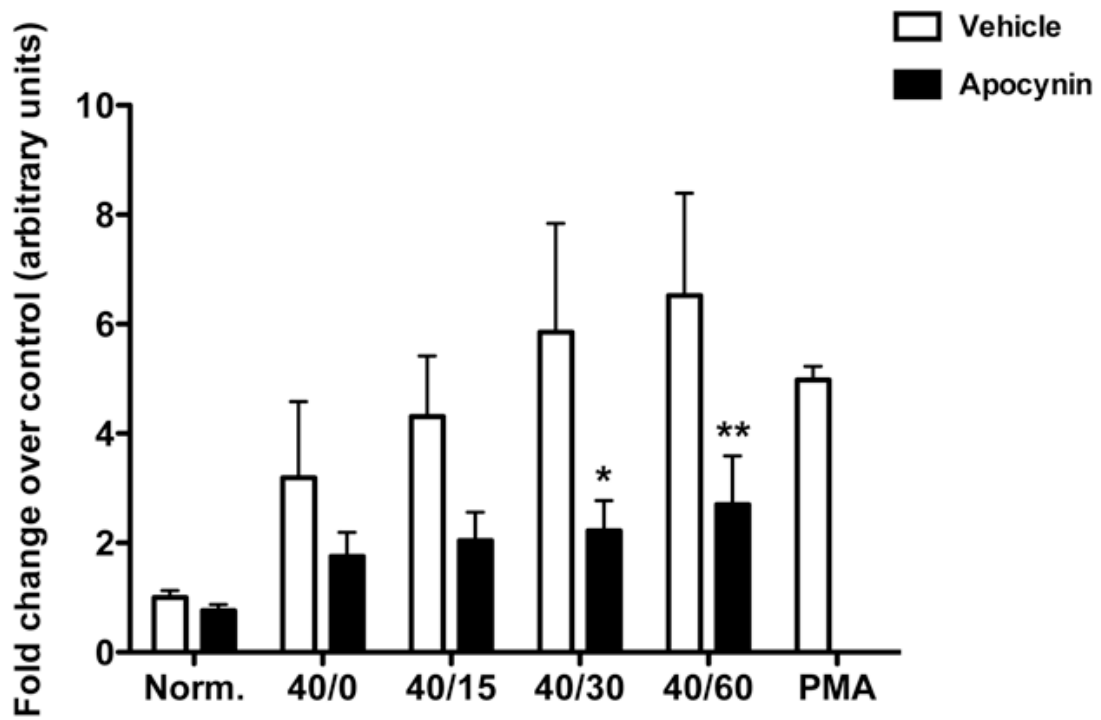
**Figure 1. GluA2 is selectively degraded following OGD/R exposure.** Representative Western blot (A) of hippocampal slices illustrates the time course of GluA2 degradation. Quantification (B) of GluA2 protein levels. Data represents fold change over control  $\pm$  S.D. from four separate experiments. \* $p < 0.05$ , ANOVA with post hoc Bonferroni test. Results are expressed as arbitrary densitometry units.

Figure 2.

A.



B.



**Figure 2. NADPH oxidase activity contributes to reactive oxygen species generation during reperfusion.** (A) Phase contrast images of vehicle (DMSO) and apocynin (30  $\mu$ M) pretreated hippocampal slices loaded with NBT were collected on a fluorescent dissecting scope, phorbol 12-myristate 13-acetate (PMA; 10  $\mu$ M, 10 minutes) was used as a positive control for NADPH oxidase activation. (B) Reduced NBT was quantified by cellular lysis in DMSO with the absorbance of the resultant supernatant being collected at 550 nm. Data represents fold change over control  $\pm$  S.D. from 5 separate experiments. \* $p$  <0.05, ANOVA with post hoc Bonferroni test. Results are expressed as arbitrary densitometry units.

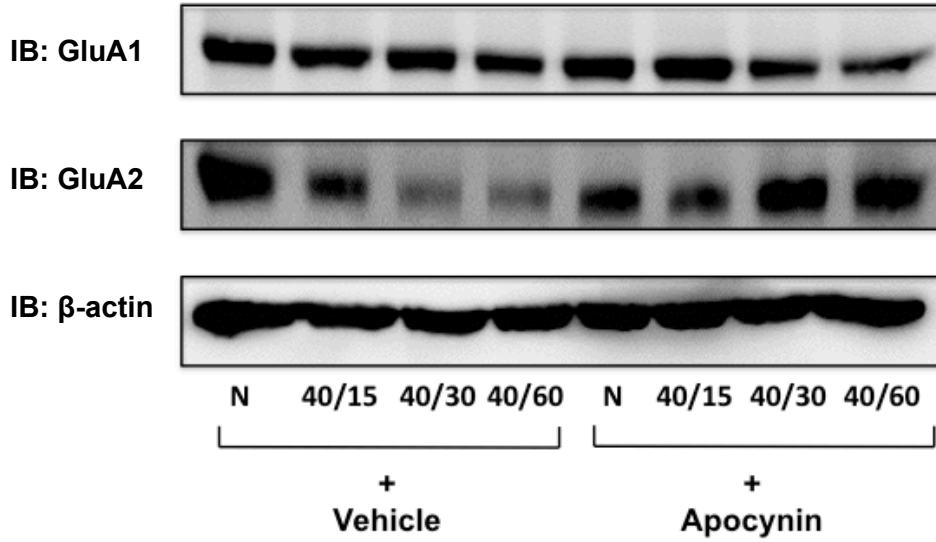
### **Inhibition of NADPH oxidase prevents the OGD/R-induced degradation of GluA2.**

Inhibition of NADPH oxidase activity prevented the OGD/R-induced degradation of GluA2 (Figure 3). However, NADPH oxidase is not the only ROS generator that has been shown to contribute to post-ischemic neuronal injury. The generation of ROS and oxidative stress have been shown to contribute to neuronal injury by several mechanisms during ischemia and reperfusion, including mitochondria and xanthine oxidase.<sup>45</sup> To determine whether other ROS generators may be involved in the decrease in GluA2 protein levels, slices were pre-treated with the xanthine oxidase inhibitor oxypurinol (20  $\mu$ M), and the mitochondrial uncoupler FCCP (0.5  $\mu$ M). The concentrations of oxypurinol and FCCP used were previously reported to be effective in inhibiting ROS generation.<sup>45</sup> Inhibition of these two sources of ROS production failed to diminish the OGD/R-induced degradation of the GluA2 subunit (Fig. 4). A NBT assay was performed to demonstrate that the concentrations of oxypurinol and FCCP used were effective in inhibiting ROS generated by these ROS generators. These studies suggest that mitochondria and xanthine oxidase have little role in the OGD/R-induced degradation of GluA2. Although other ROS generators cannot be ruled out, it appears that NADPH oxidase serves as the primary ROS generator involved in initiating the oxidative stress-signaling cascade responsible for the post-ischemic degradation of the GluA2.

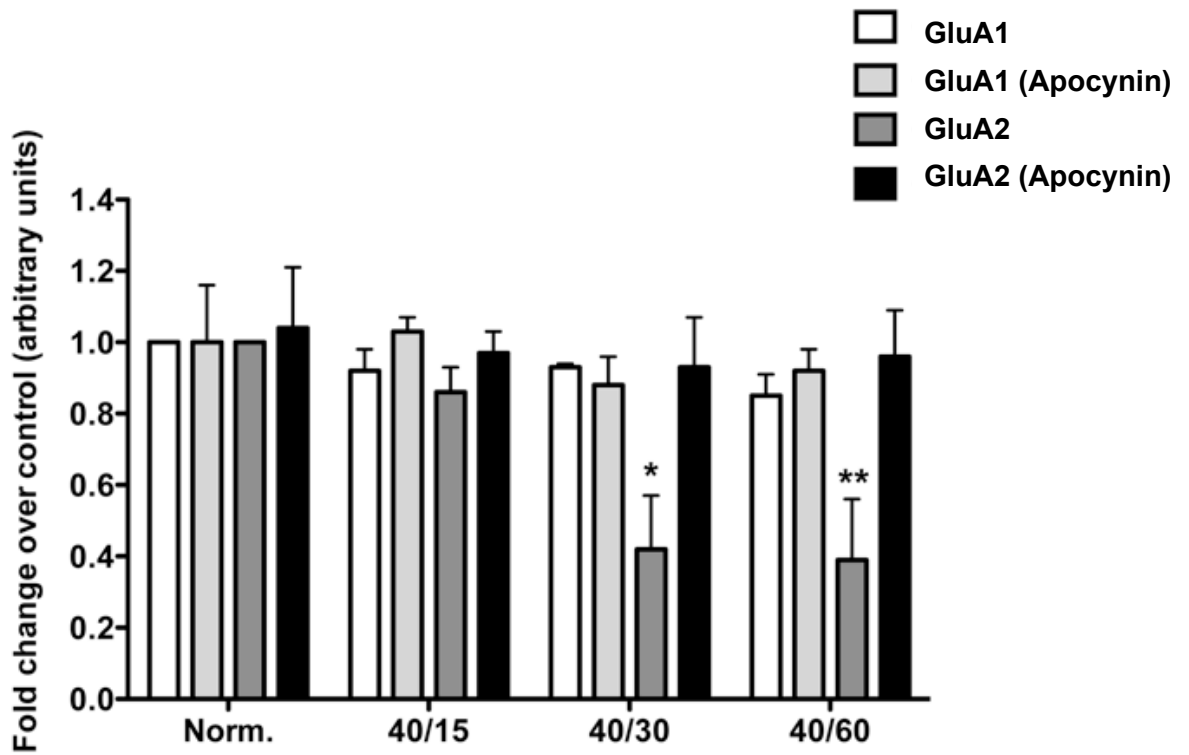
### **Inhibition of NADPH oxidase with apocynin decreases the OGD/R-induced increase in Ser880 phosphorylation of GluA2 and the association of activated PKC $\alpha$ and PICK1.**

The endocytosis of GluA2 has been demonstrated to be both preceded by and dependent on PKC $\alpha$  mediated Ser880 phosphorylation of the GluA2 subunit.<sup>58</sup> We found an overall increase in phospho-PKC $\alpha$ (Thr497) (data not shown) in total lysates. We also performed a time response experiment to determine a time course of the GluA2 Ser880 phosphorylation status in rat hippocampal slices treated to OGD/R and found that GluA2 Ser880 phosphorylation significantly increased during reperfusion while the total level of GluA2 protein decreased (Fig. 5). We sought to determine if the reduction in oxidative stress observed with the inhibition of NADPH oxidase during OGD/R resulted in an attenuation of GluA2 Ser880 phosphorylation. Inhibition of NADPH oxidase activity dampened the OGD/R-induced increase in GluA2 Ser880 phosphorylation (Fig. 5). The association of PKC $\alpha$  with PICK1 is an important step in the

Figure 3.  
A.

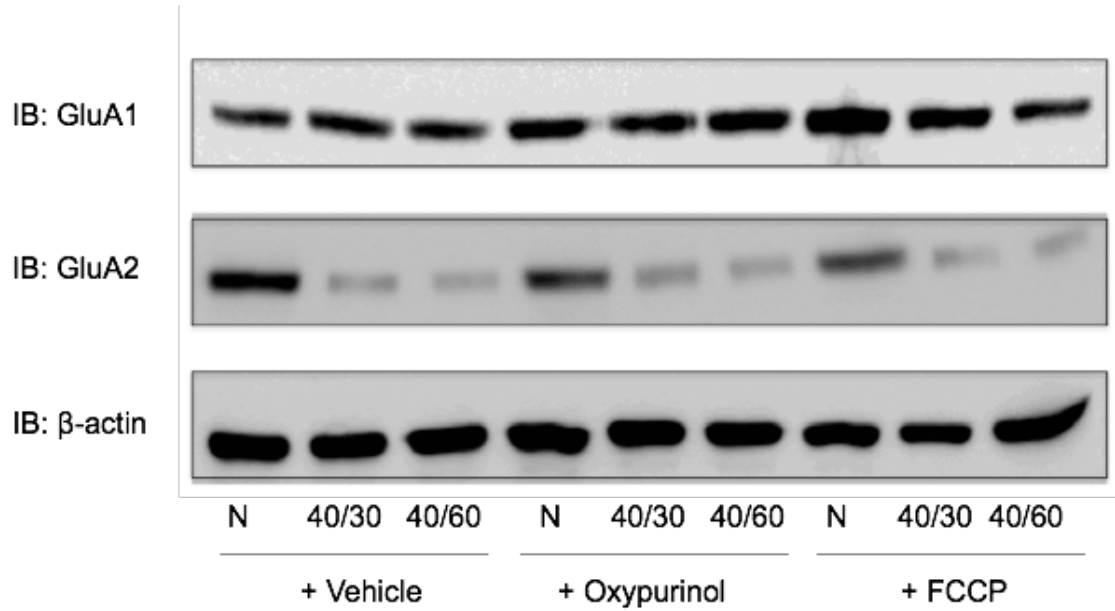


B.

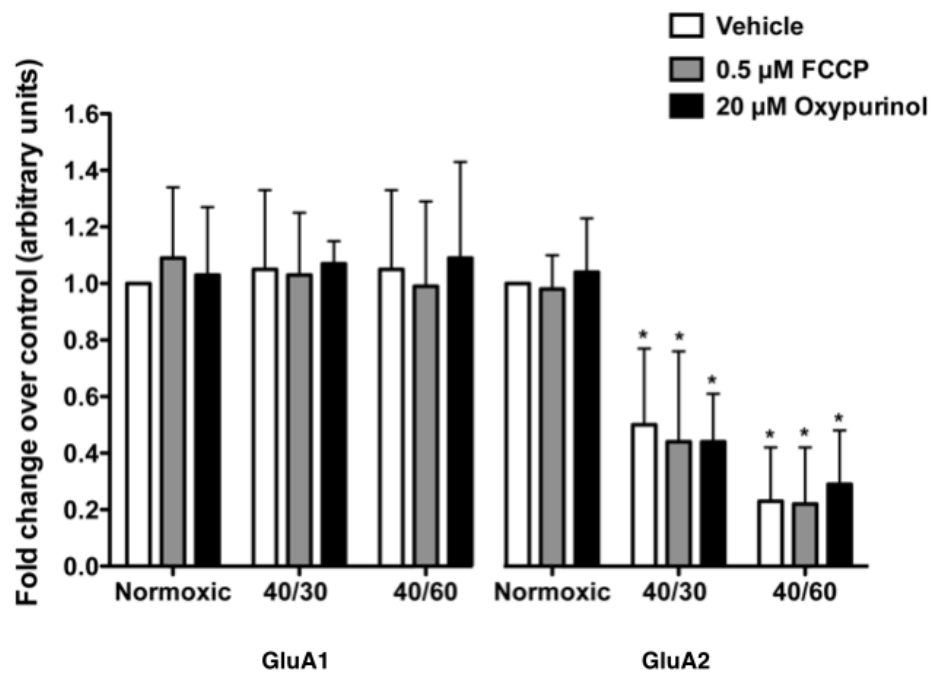


**Figure 3. Inhibition of NADPH oxidase attenuates the OGD/R-induced loss of GluA2.** Representative Western blot (A) of hippocampal slices illustrates the time course of GluA2 degradation in the presence of vehicle (1:1000 DMSO) or apocynin (30  $\mu$ M). Quantification (B) of GluA2 protein levels. Data represents fold change over control  $\pm$  S.D. from four separate experiments. \* $p < 0.05$ , ANOVA with post hoc Bonferroni test. Results are expressed as arbitrary densitometry units.

**Figure 4.**  
**A.**



**B.**

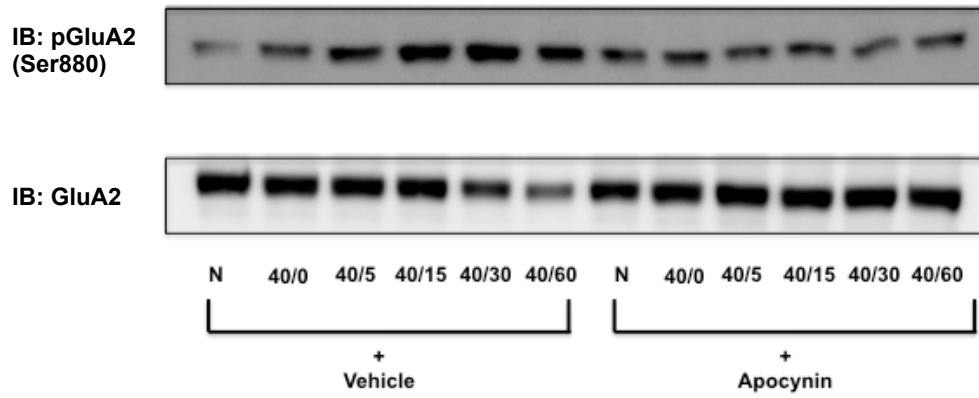




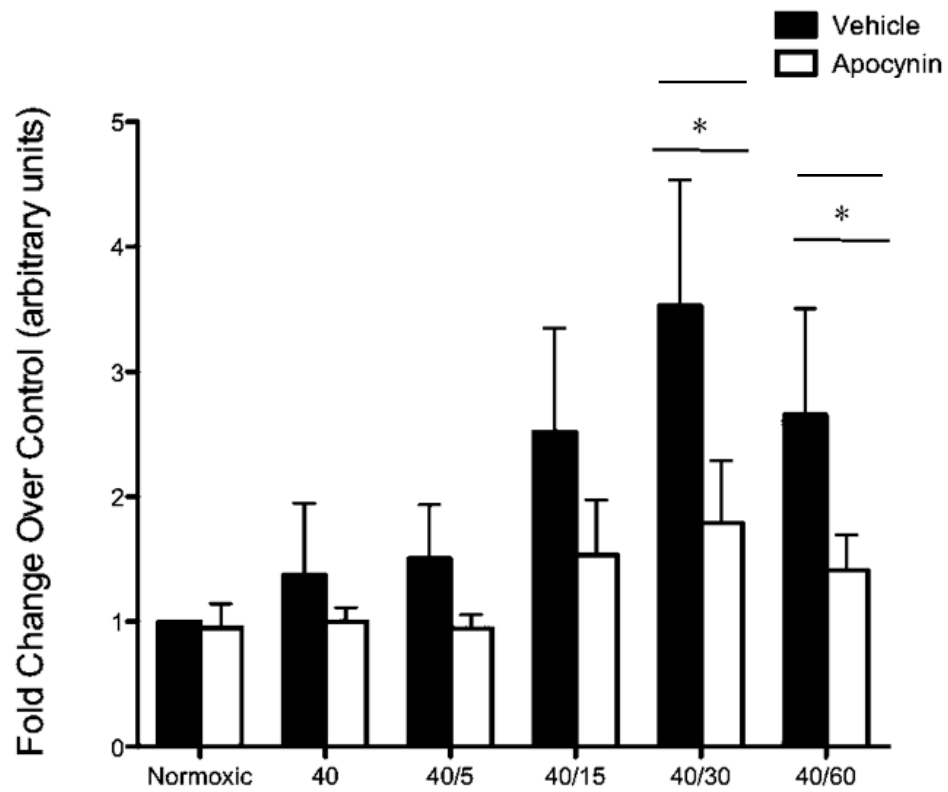
**Figure 4. Inhibition of mitochondrial and xanthine oxidase ROS generation fails to rescue the OGD/R-induced loss of GluA2.** (A) Lysates were prepared from rat hippocampal slices exposed to OGD/R with vehicle (1:000 DMSO), Oxypurinol (20  $\mu$ M), or FCCP (0.5  $\mu$ M). Representative Western blot (A) of four independent experiments demonstrates the selective decrease in GluA2 protein levels, which is not rescued with either the xanthine oxidase inhibitor oxypurinol or the mitochondrial uncoupler FCCP. (B) Data are expressed as fold change over control  $\pm$  S.D.  $*p < 0.05$ , ANOVA with post hoc Bonferroni test. Results are expressed as arbitrary densitometry units.

Figure 5.

A.



B.



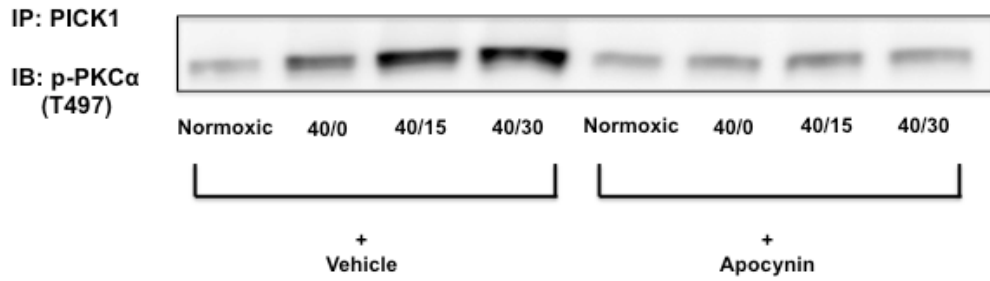
**Figure 5. The OGD/R-induced increase in Ser880 phosphorylation of GluA2 is blunted with inhibition of NADPH oxidase.** Representative Western blot (A) of hippocampal slices illustrates the time course of GluA2 Ser880 phosphorylation in the presence of vehicle (1:1000 DMSO) or apocynin (30  $\mu$ M). Quantification (B) of GluA2 phosphorylation levels. Data represents fold change over control  $\pm$  S.D. from three separate experiments. \* $p < 0.05$ , ANOVA with post hoc Bonferroni test. Results are expressed as arbitrary densitometry units.

endocytosis of GluA2. Activation of PKC $\alpha$  causes PKC $\alpha$  to bind to the PICK1 PDZ domain, the PKC $\alpha$ -PICK1 complex is targeted to the ABP/GRIP-GluA2 complex, this complex anchors AMPARs to the plasma membrane. PICK1 competes with ABP/GRIP for the GluA2 interaction. PKC $\alpha$  phosphorylates Ser880 of GluA2, GluA2 phosphorylated at Ser880 has a decreased affinity for ABP/GRIP, thus enabling the binding of PICK1 to GluA2. The interaction of PICK1 with GluA2 has been shown to be important in decreasing surface levels of GluA2.<sup>59-61</sup> Therefore, experiments were performed to determine if exposure to OGD/R lead to an increase in the association of activated PKC $\alpha$  with PICK1. Reperfusion of OGD-treated slices resulted in a rapid and sustained phospho-PKC $\alpha$ -PICK1 association (Fig. 6). Additionally, inhibition of NADPH oxidase activity dampened the OGD/R-induced association of activated PKC $\alpha$  with PICK1 (Fig. 6). These experiments show that NADPH oxidase contributes to the post-OGD/R sustained activation of PKC $\alpha$  associated with PICK1 and the subsequent increase in GluA2 Ser880 phosphorylation.

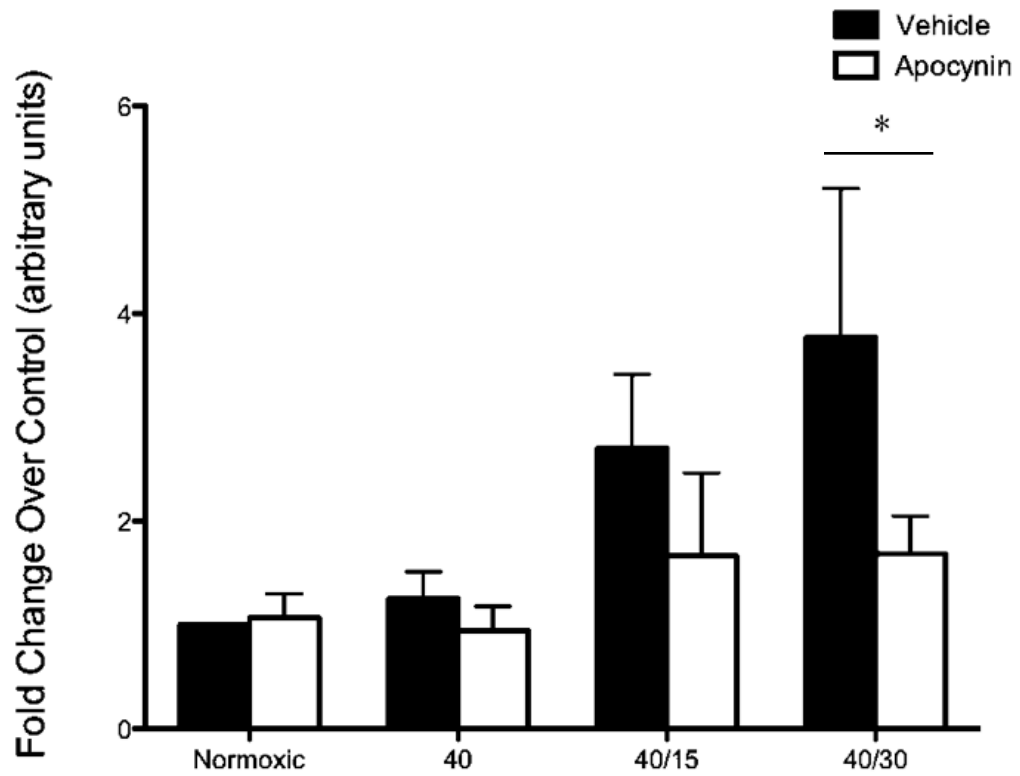
#### **Inhibition of NADPH oxidase prevents the OGD/R-induced inactivation of PP2A.**

A balance in activity of protein kinases and phosphatases is required for the regulation of protein phosphorylation. It has been demonstrated that PP2A plays a role in regulating PKC activity.<sup>30</sup> It has also been reported that H<sub>2</sub>O<sub>2</sub> generated ROS inhibits PP2A, while treatment with a ROS scavenger reversed inactivation.<sup>62</sup> Therefore, the previously demonstrated OGD/R-induced sustained increase in PKC $\alpha$  phosphorylation may be mediated by the inactivation of PP2A. Phosphorylation of PP2A at Tyr307 results in the inactivation of the phosphatase.<sup>30,62</sup> Experiments were performed to determine if PP2A undergoes OGD/R-induced inactivation, and if so, does inhibition of NADPH oxidase attenuate PP2A inactivation. We show an OGD/R-induced increase in PP2A Tyr307 phosphorylation, indicating an inactivation of the phosphatase (Fig. 7). Apocynin inhibition of NADPH oxidase attenuated the OGD/R-induced phosphorylation of PP2A (Fig. 8), suggesting that NADPH oxidase was responsible for the inactivation of PP2A.

Figure 6.  
A.



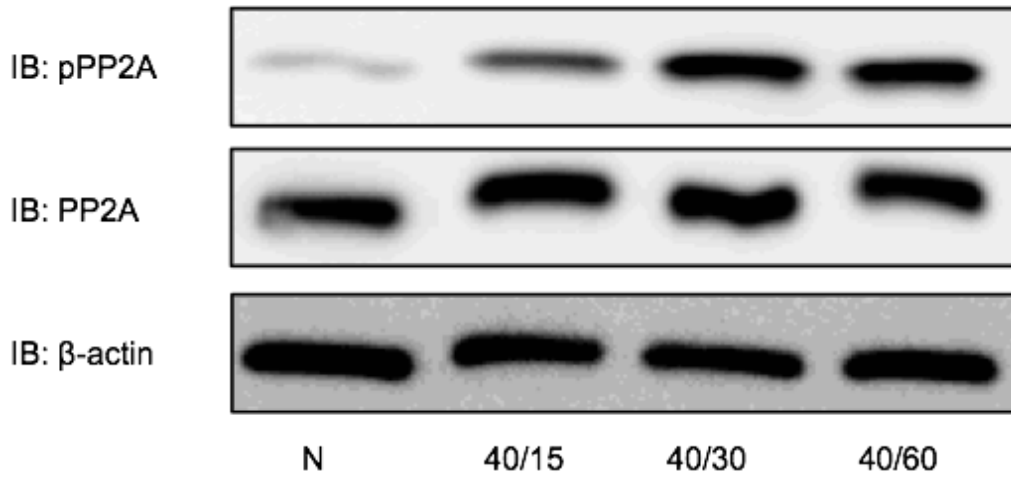
B.



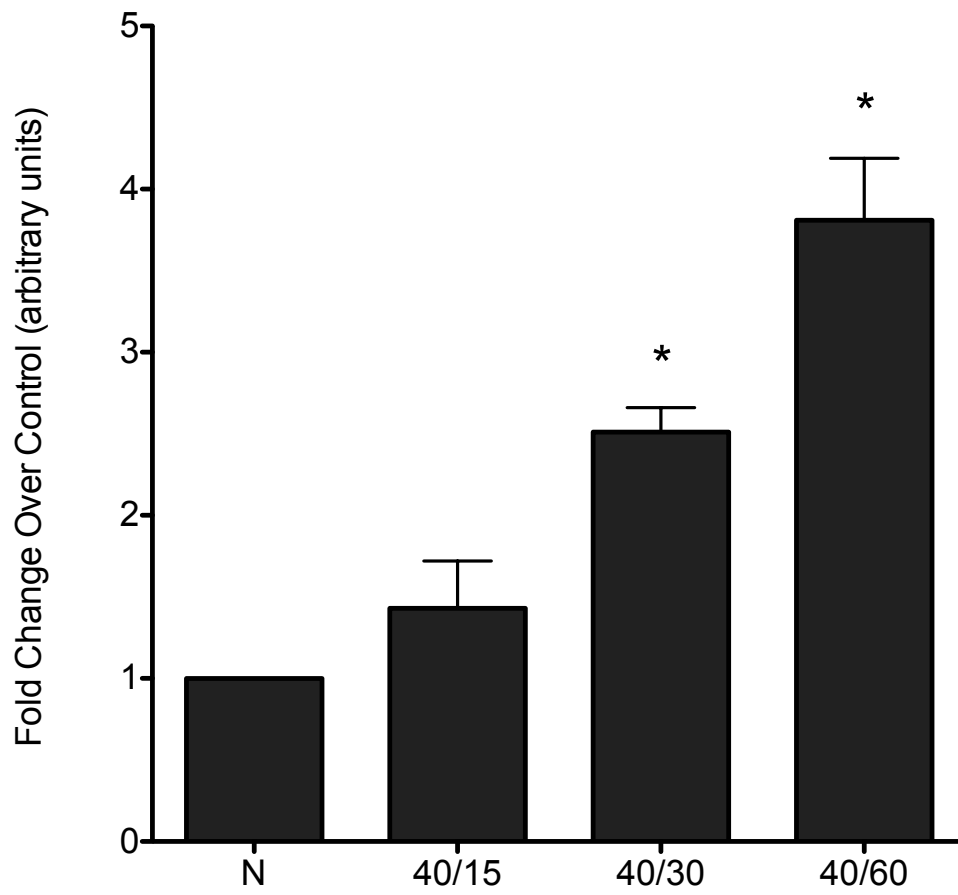
**Figure 6. The OGD/R-induced increase in activated PKC $\alpha$  associated with PICK1 is blunted with inhibition of NADPH oxidase.** Representative Western blot (A) of hippocampal slice illustrates the PKC $\alpha$  (phospho-Thr497)-PICK1 association in the presence of vehicle (1:1000 DMSO) or apocynin (30  $\mu$ M). Quantification (B) of phospho-PKC $\alpha$ (Thr497)-PICK1 association. Data represents fold change over control  $\pm$  S.D. from three separate experiments. \* $p < 0.05$ , ANOVA with post hoc Bonferroni test. Results are expressed as arbitrary densitometry units.

Figure 7.

A.



B.



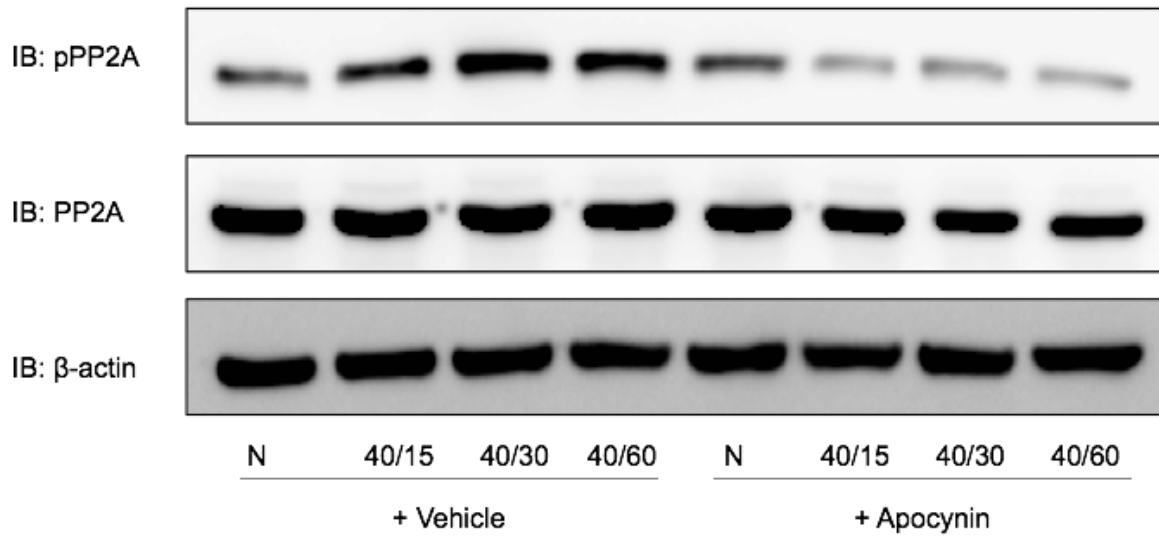
**Figure 7. PP2A undergoes Tyr307 phosphorylation following OGD/R exposure.**

Representative Western blot (A) of hippocampal slices illustrates the time course of PP2A Tyr307 phosphorylation. Quantification (B) of PP2A Tyr307 phosphorylation levels. Data represents fold change over control  $\pm$  S.E.M. from three separate experiments. \* $p < 0.05$ , ANOVA with post hoc Bonferroni test. Results are expressed as arbitrary densitometry units.

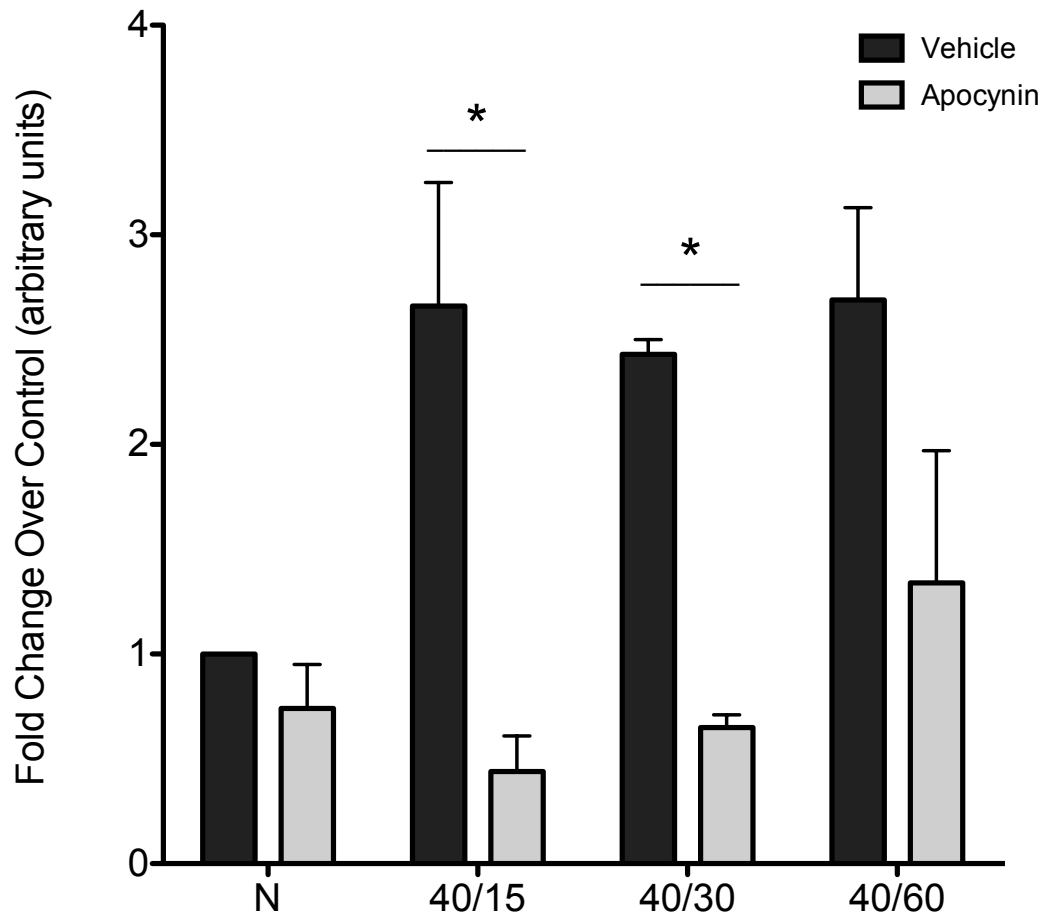


Figure 8.

A.



B.



**Figure 8. Inhibition of NADPH oxidase attenuates the OGD/R-induced increase in PP2A Tyr307 phosphorylation.** Representative Western blots (A) of hippocampal slices illustrates the time course of PP2A Tyr307 phosphorylation in the presence of vehicle (1:1000 DMSO) or apocynin (30  $\mu$ M). Quantification (B) of PP2A phosphorylation levels. Data represents fold change over control  $\pm$  S.E.M. from three separate experiments. \* $p < 0.05$ , ANOVA with post hoc Bonferroni test. Results are expressed as arbitrary densitometry units.

## DISCUSSION

Following ischemic injury, AMPARs undergo a subunit rearrangement resulting in the expression of GluA2-lacking  $\text{Ca}^{2+}/\text{Zn}^{2+}$ -permeable AMPARs which play a key role in promoting delayed neuronal death. It has been demonstrated that ischemia triggers the down regulation of GluA2 protein expression.<sup>2,31-33</sup> However, the underlying signaling mechanisms are still poorly understood. We previously demonstrated that inhibition of NADPH oxidase prevented the OGD/R-induced degradation of GluA2. Here, we show that inhibition of ROS generated by mitochondria and xanthine oxidase fails to diminish the OGD/R-induced degradation of GluA2. Thereby indicating that NADPH oxidase is the ROS generator involved in initiating the oxidative stress-signaling cascade responsible for the post-ischemic degradation of the GluA2.

In addition, we found that PP2A undergoes increased Tyr307 phosphorylation following OGD/R and inhibition of NADPH oxidase with apocynin attenuates the OGD/R-induced inactivation of PP2A. We demonstrated an OGD/R-induced increase in GluA2 Ser880 phosphorylation and activated PKC $\alpha$  and PICK1 association. Inhibition of NADPH oxidase with apocynin diminished the OGD/R-induced increase in activated PKC $\alpha$  and PICK1 association and subsequent Ser880 phosphorylation of GluA2. To determine how NADPH oxidase regulates activated PKC $\alpha$  we examined phosphatase inactivation. PP2A mediates the dephosphorylation of PKC<sup>23,24</sup> and undergoes  $\text{H}_2\text{O}_2$  generated ROS induced inactivation.<sup>62</sup> Therefore, the NADPH oxidase mediated OGD/R-induced inactivation of PP2A, may be responsible for the sustained activation of PKC $\alpha$  and subsequent phosphorylation of GluA2. Additionally, activated Src can phosphorylate Tyr307 directly, causing PP2A inactivation, furthermore Src activity is up-regulated following ischemic injury.<sup>30</sup> The Src family of non receptor protein tyrosine kinases regulate a wide variety of physiological responses including extracellular signals derived from G-protein-coupled receptors, ion channels, and cell-cell adhesion signaling molecules. SFKs have been shown to play a prominent role in ischemic injury. These kinases potentiate the activity of NMDARs and voltage-gated calcium and potassium channels, all known contributors to ischemic cell death.<sup>63</sup> In particular, following ischemia there is a sustained activation of SFKs. These activated kinases are subsequently recruited to the plasma membrane, resulting in an up-regulation of NDMAR function and an

increase in the open state of coupled ion channels, allowing a massive calcium influx and subsequent IRI.<sup>64</sup> Inhibition of SFKs results in a reduction in infarct volume and increased neurological recovery (increased sensorimotor function and reflex limb placement).<sup>63</sup> These results suggest that SFK inhibitors may be a viable therapy for acute stroke.

Inactivation of other phosphatases may also play a role in the sustained phosphorylation of PKC $\alpha$  and GluA2. PP1 is a serine/threonine phosphatase that plays a crucial role in multiple cellular processes including cell division, transcription, translation, and apoptosis. The catalytic subunits of PP1 are highly expressed in brain tissue, implying an important role for the phosphatase in the CNS.<sup>65</sup> Dephosphorylation of GluA2 is mediated by PP1, suggesting that PKC $\alpha$  and PP1 have opposing roles in the regulation of GluA2 Ser880 phosphorylation.<sup>66</sup> In addition to PP2A, PP1 also has a role in regulating PKC activity.<sup>23,24</sup> Phosphorylation regulates PP1 activity, PP1 is inactivated when phosphorylated at T320.<sup>67</sup> Interestingly, PP1 activity is inhibited by oxidative stress.<sup>68</sup> Therefore, ROS-mediated inactivation of PP1 following ischemia may also lead to a sustained phosphorylation of PKC $\alpha$  and GluA2.

The decrease in surface levels of GluA2 is mediated by the internalization of GluA2. Phosphorylation of Ser880, within the GluA2 PDZ-binding site, by PKC $\alpha$  decreases the affinity of GluA2 for synaptic anchoring proteins GRIP1 and ABP, thus allowing the association of PICK1 with GluA2 and internalization.<sup>20-22</sup> It has been demonstrated that viral expression of peptides that interfere with PICK1 PDZ binding domain interactions prevent the ischemic-induced switch of GluA2-containing AMPARs.<sup>69</sup> It has also been shown that following NMDAR activation FSC 231, a small-molecule inhibitor of the PICK1 PDZ domain, accelerates the recycling of internalized GluA2 back to the surface.<sup>70</sup> Therefore, preventing PICK1 PDZ domain interactions may prevent the ischemic-induced loss of GluA2-containing AMPARs and ultimately protect against calcium permeable AMPAR mediated delayed neuronal death.

## **IMPACT**

Stroke is the third leading cause of death and the leading cause of disability in the United States.<sup>71,72</sup> Although multiple pharmacological agents have demonstrated efficacy in reducing stroke injury in preclinical studies, the only approved drug for stroke patients is the thrombolytic, rtPA. Currently only 2-5% of stroke patients in the U.S. receive rtPA, due to the narrow therapeutic window and associated risks, including hemorrhage.<sup>71,72</sup> There is a great need for the generation of neuroprotective agents against IRI.

The ischemic core is the center of the brain region with diminished blood flow following ischemia. In this region, neurons undergo irreversible death within minutes. The penumbra is the region surrounding the core, neurons here remain quiescent due to collateral blood supply. If blood flow is not restored to the penumbra, neurons in this region will eventually die.<sup>72</sup> Neuroprotection is designed to restrict injury to the brain following an ischemic insult by preventing neuronal cell death, especially in the salvageable penumbral region.<sup>73</sup>

It is widely accepted that deprivation of oxygen and glucose to neuronal tissue elicits a series of pathological cascades, leading to the spread of neuronal death. Excessive activation of glutamate receptors, over-load of intracellular calcium, abnormal recruitment of inflammatory cells and excessive production of free radicals are believed to play crucial roles in ischemic damage.<sup>74</sup> Neuroprotective agents designed to interrupt the propagation of these pathological cascades have been investigated in stroke studies.<sup>74</sup> Over 1000 neuroprotective agents have been tested in experimental studies, with many showing efficacy, however neuroprotection has failed in clinical trials.<sup>73</sup> There are many reasons for the translational difficulties (Table 2) including a lack of methodological agreement between preclinical and clinical studies and the heterogeneity of stroke in humans compared to homogeneous stroke in animal models.<sup>72,73</sup> Overall, there is a need for new animal models and more rigorous studies with higher standard levels to avoid bias.

Other strategies to improve the outcome after stroke include neurorestorative approaches aimed at remodeling brain tissue. Another potential strategy is combination therapy, using a neuroprotective agent alongside thrombolysis.<sup>73</sup> The promise of combination and neurorestorative therapies need further clinical investigation before the viability of these strategies can be confirmed. The failed translation from animal stroke studies to clinical studies

**Table 2. Reasons for translational failure of neuroprotective agents from pre-clinical to clinical studies.<sup>73</sup>**

Animal models	Human studies
Highly controlled, homogeneous population	Variable, heterogeneous population
Younger animals	Older patients
Limited comorbidities	Numerous comorbidities
Induced onset of stroke	Spontaneous onset of stroke
Uniform aetiology	Variable aetiologies
Ischaemic territory usually from middle cerebral artery	Ischaemic territory not restricted to middle cerebral artery
Control over therapeutic time window (usually early treatment)	Less control over therapeutic time window (usually delayed treatment)
Controlled occlusion duration	Variable occlusion duration
Adequate sample size	Inadequate sample size
Wide scope for dose optimization	Reduced scope for dose optimization
Multiple routes of administration	Limited routes of administration
Rapid availability of the drugs to the target area	Slow availability of the drugs to the target area
Infarct volume as outcome	Function as outcome

has created pessimism regarding the neuroprotection hypothesis. Although recent stroke research has not directly yielded new clinical drugs, it has provided important mechanistic insights into the complex pathophysiology of ischemic stroke.<sup>72</sup> Still, there are a number of questions that remain unanswered that may help identify future targets for stroke therapy.

The research presented here leaves questions for future studies to examine. It has been demonstrated that Src activity is increased following ischemia and is responsible for the inactivation of PP2A.<sup>30</sup> Does NADPH oxidase have a role in regulating Src activity? In SH-SY5Y cells, we demonstrated that inhibition of NADPH oxidase attenuated the OGD/R-induced association of activated Src with PSD-95.<sup>75</sup> Do PP2A activators or Src inhibitors prevent the internalization of GluA2, can they be used as potential targets for stroke therapy? PP2A is involved in numerous cellular processes, therefore activating all forms may produce unwanted or even detrimental side effects.<sup>25,26</sup> The ability to directly target a specific PP2A holoenzyme may be beneficial. This could potentially be accomplished by disrupting the association between PP2A and its substrates. A better understanding of PP2A complexes and PP2A-AKAP compartmentalization during ischemia is necessary to achieve this.

NADPH oxidases are a major source of ROS. Future stroke studies should attempt to target specific enzymatic sources of ROS rather than applying non-specific antioxidants after radicals have already been generated.<sup>72</sup> We demonstrated that inhibition of NADPH oxidase prevented the sustained activation of PKC $\alpha$ , the Ser880 phosphorylation of GluA2, and the degradation of GluA2. However, it is still unclear which NOX family members are responsible. It has been demonstrated that NOX4-derived oxidative stress has a role in the pathophysiology of ischemia. NOX4 is functionally induced in neurons and brain vessels of human stroke patients and mice. Additionally, inhibition of NOX4 in stroke mice promotes neuroprotection.<sup>73</sup> Future studies should aim at understanding the exact role each NOX isoform has in IRI. Subtype-specific NADPH oxidase inhibitors may be attractive treatment options in ischemic injury and other disease states related to oxidative stress.

The OGD/R-induced trafficking of AMPARs remains unclear. Although both GluA1 and GluA2 internalize during reperfusion, only GluA2 is degraded, suggesting differential trafficking of the internalized subunits. Examination of protein-protein interactions and the association of

GluA1 and GluA2 with different endocytic compartments would provide a better understanding of the mechanisms underlying the degradation of GluA2. Elucidation of these mechanism may also provide insight into other neurological disorders, in which Ca<sup>2+</sup>-permeable AMPARs are also implicated, including epilepsy, ALS, and Alzheimer's disease.<sup>5</sup>

Finally, further investigation into the disruption of PICK1 PDZ domain interactions may generate new therapeutics that prevent the post-ischemic AMPAR-mediated neuronal death.



## BIBLIOGRAPHY

1. Attwell D and Gibb A. Neuroenergetics and the kinetic design of excitatory synapses. (2005). *Nature Reviews* 6:841-849.
2. Tanka H, Grooms SY, Bennett MVL, Zukin RS. The AMPAR subunit GluR2: still front and center-stage. (2000). *Brain Res* 886:190-207.
3. Henley JM and Wilkinson KA. AMPA Receptor Trafficking and the Mechanisms Underlying Synaptic Plasticity and Cognitive Aging. (2013). *Dialogues in Clinical Neuroscience* 15(1).
4. Anggono V and Huganir RL. Regulation of AMPA Receptor Trafficking and Synaptic Plasticity. (2012). *Curr Opin Neurobiol* 22:461-469.
5. Liu SJ and Zukin RS. Ca<sup>2+</sup>-permeable AMPA receptors in synaptic plasticity and neuronal death. (2007). *Trends Neurosci* 30(3):126-134.
6. Wright A and Vissel B. The essential role of AMPA receptor GluA2 subunit RNA editing in the normal and diseased brain. (2012). *Front Mol Neurosci* 5(34).
7. Shimshek DR, Bus T, Grinevich V, Single FN, Mack V, Sprengel R, Spergel DJ, Seeburg PH. Impaired reproductive behavior by lack of GluR-B containing AMPA receptors but not of NMDA receptors in hypothalamic and septal neurons. (2006). *Mol. Endocrinol.* 20:219–231.
8. Yan J, Zhang Y, Jia Z, Taverna FA, McDonald RJ, Muller RU, Roder JC. Place-cell impairment in glutamate receptor 2 mutant mice. (2002). *J. Neurosci.* 22.
9. Isaac JTR, Ashby MC, McBain CJ. The Role of the GluR2 Subunit in AMPA Receptor Function and Synaptic Plasticity. (2007). *Neuron* 54:859-871.
10. Cull-Candy S, Kelly L, Farrant M, Regulation of Ca<sup>2+</sup>-permeable AMPA receptors: synaptic plasticity and beyond. (2006). *Current Opinion in Neurobiology* 16:288-297.
11. Choy MS, Page R, Peti W. Regulation of protein phosphatase 1 by intrinsically disordered proteins. (2012). *Biochem Soc Trans* 40(5):969-974.
12. Lohmann C and Kessels HW. The Developmental Stages of Synaptic Plasticity. (2013). *J Physiol* 592(1):13-31.

13. Newton AC. Protein Kinase C: Structure, Function, and Regulation. (1995). *J Biol Chem* 270:28495-28498.
14. Webb BJ, Hirst SJ, Giembycz MA. Protein kinase C isoenzymes: a review of their structure, regulation and role in regulating airways smooth muscle tone and mitogenesis. (2000). *British Journal of Pharmacology* 130:1433-1452.
15. Schmitz-Peiffer C and Biden TJ. Protein Kinase C Function in Muscle, Liver, and  $\beta$ -Cells and Its Therapeutic Implications for Type 2 Diabetes. (2008). *Diabetes* 57:1174-1783.
16. Wong W and Scott J.D. AKAP signaling complexes: focal points in space and time. (2004). *Nature Reviews* 5:959-970.
17. Ahn SM, Choe ES. Alterations in GluR2 AMPA Receptor Phosphorylation at Serine 880 Following Group I Metabotropic Glutamate Receptor Stimulation in the Rat Dorsal Striatum. (2010). *J Neurosci Res* 88:992-999.
18. Chung HE, Xia J, Scannevin RH, Zhang X, Huganir, RL. Phosphorylation of the AMPA Receptor Subunit GluR2 Differentially Regulates Its Interaction with PDZ Domain-Containing Proteins. (2000). *J Neurosci* 20(19):7258-7267.
19. Kim CH, Chung HJ, Lee HK, Huganir RL. Interaction of the AMPA receptor subunit GluR2/3 with PDZ domains regulates hippocampal long-term depression. (2001). *PNAS* 98(20):11725-11730.
20. Shepherd JD and Huganir RL. The Cell Biology of Synaptic Plasticity: AMPA Receptor Trafficking. (2007). *Annu Rev Cell Dev Biol* 23:613-643.
21. Lu W and Ziff B. PICK1 Interacts with ABP/GRIP to Regulate AMPA Receptor Trafficking. (2005). *Neuron* 47:407-421.
22. Malinow R and Malenka RC. AMPA Receptor Trafficking and Synaptic Plasticity. (2002). *Annu Rev Neurosci* 25:103-126.
23. Ricciarelli R and Azzi Angelo. Regulation of Recombinant PKC Activity by Protein Phosphatase 1 and Protein Phosphatase 2A. (1998). *Archives of Biochemistry and Biophysics* 355(2):197-200.
24. Keranen LM, Dutil EM, Newton AC. Protein kinase C is regulated in vivo by three functionally distinct phosphorylations. (1995). *Current Biology* 5:1394-1403.

25. Xu Y, Xing Y, Chen Y, Chao Y, Lin Z, Fan E, Yu JW, Strack S, Jeffrey PD, Shi Y. Structure of the Protein Phosphatase 2A Holoenzyme. (2006). *Cell* 127:1239-1251.
26. Shi Y. Assembly and structure of protein phosphatase 2A. (2009). *Sci China Ser C-Life Sci* 52(2):135-146.
27. Soprano KJ, Purev E, Vuocolo S, Soprano DR. Rb2/p130 and protein phosphatase 2A: key mediators of ovarian carcinoma cell growth suppression by all-trans retinoic acid. (2006). *Oncogene* 25:5315-5325.
28. Janssens V and Goris J. Protein phosphatase 2A: a highly regulated family of serine/threonine phosphatases implicated in cell growth and signaling. (2001). *Biochem J* 353:417-439.
29. Winder DG and Sweatt JD. Roles of Serine/Threonine Phosphatases in Hippocampal Synaptic Plasticity. (2001). *Nature Reviews* 2:461-474.
30. Hu X, Wu X, Xu J, Zhou J, Han X, Guo J. Src kinase up-regulates the ERK cascade through inactivation of protein phosphatase 2A following cerebral ischemia. (2009). *BMC Neurosci* 10:74.
31. Liu B, Liao M, Mielke JG, Ning K, Chen Y, Li L, El-Hayek YH, Gomez E, Zukin RS, Fehlings G, Wan Q. Ischemic Insults Direct Glutamate Receptor Subunit 2-Lacking AMPA Receptors to Synaptic Sites. (2006). *J Neurosci* 26(20): 5309-5319.
32. Pellegrini-Giampietro DE, Zukin RS, Bennett MV, Cho S, Pulsinelli WA. Switch in glutamate receptor subunit gene expression in CA1 subfield of hippocampus following global ischemia in rats. (1992). *Proc Natl Acad Sci* 89:10499 –10503.
33. Gorter JA, Petrozzino JJ, Aronica EM, Rosenbaum DM, Opitz T, Bennett MV, Connor JA, Zukin RS. Global ischemia induces down regulation of Glur2 mRNA and increases AMPA receptor-mediated Ca<sup>2+</sup> influx in hippocampal CA1 neurons of gerbil. (1997). *J Neurosci* 17:6179 – 6188.
34. Weiss JH, Sensi SL. Ca<sup>2+</sup>-Zn<sup>2+</sup> permeable AMPA or kainate receptors: possible key factors in selective neurodegeneration. (2000). *Trends Neurosci* 23:365–371.
35. Liu S, Lau L, Wei J, Zhu D, Zou S, Sun HS, Fu Y, Liu F, Lu Y. Expression of Ca<sup>2+</sup>-permeable AMPA receptor channels primes cell death in transient forebrain ischemia. (2004). *Neuron* 43:43–55.

36. Noh KM, Yokota H, Mashiko T, Castillo PE, Zukin RS, Bennett MV. Blockade of calcium-permeable AMPA receptors protects hippocampal neurons against global ischemia-induced death. (2005). *Proc Natl Acad Sci* 102:12230–12235.
37. Peng PL, Zhong X, Tu W, Soundarapandian MM, Molner P, Zhu D, Lau L, Liu S, Liu F, Lu Y. ADAR2-dependent RNA editing of AMPA receptor subunit GluR2 determines vulnerability of neurons in forebrain ischemia. (2006). *Neuron* 49:719–733.
38. Gourdin MJ, Bree B, De Kock M. The impact of ischemia–reperfusion on the blood vessel. (2009). *Eur J Anaesthesiol* 26:537–547.
39. Yellon DM, Hausenloy DJ. Myocardial reperfusion injury. (2009). *N Engl J Med* 357:1121–1135.
40. Elahi MM, Kong YX, Matata BM. Oxidative stress as a mediator of cardiovascular disease. (2009). *Oxid Med Cell Longev* 2:259–269.
41. Griendling KK, Sorescu D, Ushio-Fukai M. NADPH oxidase: role in cardiovascular biology and disease. (2000). *Circ Res* 86:494–501.
42. Kleikers PWM, Wingler K, Hermans JJR, Diebold I, Altenhöfer S, Radermacher KA, Janssen B, Görlach A, Schmidt HHHW. NADPH oxidases as a source of oxidative stress and molecular target in ischemia/reperfusion injury. (2012). *J Mol Med* 90:1391-1406.
43. Suh SW, Shin BS, Ma H, Hoecke MV, Brennan AM, Yenari MA, Swanson RA. Glucose and NADPH Oxidase Drive Neuronal Superoxide Formation in Stroke. (2008). *Ann Neurol* 64:654-663.
44. Pacher P, Nivorozhkin A, Szabó C. Therapeutic effects of xanthine oxidase inhibitors: renaissance half a century after the discovery of allopurinol. (2006). *Pharmacol Rev* 58:87-114.
45. Abramov AY, Scorziello A, Duchen MR. Three Distinct Mechanisms Generate Oxygen Free Radicals in Neurons and Contribute to Cell Death during Anoxia and Reoxygenation. (2007). *J Neurosci* 27(5):1129-1138.
46. Berry CE, Hare JM. Xanthine oxidoreductase and cardiovascular disease: molecular mechanisms and pathophysiological implications. (2004). *J Physiol* 16:589–606.
47. Di L and Bernardi P. Mitochondria and ischemia–reperfusion injury of the heart: fixing a hole. (2006). *Cardiovasc Res* 70:191–199.
48. Di L, Canton M, Menabo R, Kaludercic N, Bernardi P. Mitochondria and cardioprotection. (2007). *Heart Fail Rev* 12:249–260.

49. Thiels E, Urban N.N, Gonzalez-Burgos G.R, Kanterewicz B.I, Barrionuevo G, Chu C.T, Oury T.D, Klann E. Impairment of long-term potentiation and associative memory in mice that overexpress extracellular superoxide dismutase. (2000). *J Neurosci* 20(20): 76631-7639.
50. Infanger DW, Sharma RV, Davisson, RL. NADPH Oxidases of the Brain: Distribution, Regulation, and Function. (2006). *Antioxidants and Redox Signaling* 8:1583-1596.
51. Lu Q, Wainwright MS, Harris VA, Aggarwal S, Hou Y, Rau T, Poulsen DJ, Black SM. Increased NADPH oxidase-derived superoxide is involved in the neuronal cell death induced by hypoxia–ischemia in neonatal hippocampal slice cultures. (2012). *Free Radic Biol Med* 53:1139-1151.
52. Sorce S and Krause KH. NOX Enzymes in the Central Nervous System: From Signaling to Disease. (2009). *Antioxidants and Redox Signaling* 11:2481-2504.
53. Bedard K and Krause KH. The NOX Family of ROS-Generating NADPH Oxidases: Physiology and Pathophysiology (2007). *Physiol Rev* 87:245-313.
54. Chen H, Song YS, Chan PH. Inhibition of NADPH oxidase is neuroprotective after ischemia–reperfusion. (2009). *J Cereb Blood Flow Metab* 29:1262–1272
55. Chen H, Kim GS, Okami N, Narasimhan P, Chan PH. NADPH oxidase is involved in post-ischemic brain inflammation. (2011). *Neurobiol Dis* 42:341–348
56. Yang Z, Sharma AK, Marshall M, Kron IL, Laubach VE. NADPH oxidase in bone marrow-derived cells mediates pulmonary ischemia–reperfusion injury. (2009). *Am J Respir Cell Mol Biol* 40:375–381.
57. HWang JJ, Choi SY, Koh JY. The role of NADPH oxidase, neuronal nitric oxide synthase and poly(ADP ribose) polymerase in oxidative neuronal death induced in cortical cultures by brain-derived neurotrophic factor and neurotrophin-4/5. (2002). *J Neurosci* 82:894-902.
58. Chung H.J, Xia J, Scannevin R.H, Zhang X, Huganir R.L. Phosphorylation of the AMPA receptor subunit GluR2 differentially regulates its interaction with PDZ domain-containing proteins. (2000). *J Neurosci* 20(19):7258-7267.
59. Lu W. and Ziff E.B. PICK1 interacts with ABP/GRIP to regulate AMPA receptor trafficking. (2005). *Neuron* 47:407-421.
60. Terashima A, Cotton L, Dev K.K, Meyer G, Zaman S, Duprat F, Henley J.M, Gollingridge G, Isaac J.T.R. Regulation of synaptic strength and AMPA receptor subunit composition by PICK1. (2004). *J Neurosci* 24(23):5381-5390.

61. Terashima A, Pelkey K.A, Rah J.C, Suh Y.H, Roche K.W, Collingridge G.L, McBain C.J, Isaac J.T.R. An essential role for PICK1 in NMDA receptor-dependent bidirectional synaptic plasticity. (2008). *Neuron* 57:872-882.
62. Chen L, Liu L, Luo Y, Huang S. Hydrogen peroxide-induced neuronal apoptosis is associated with inhibition of protein phosphatase 2A and 5, leading to activation of MAPK pathway. (2009). *International Journal of Biochemistry and Cell Biology* 41:1284-1295.
63. Liang S, Pong K, Gonzales C, Chen Y, Ling HP, Mark RJ, Boschelli F, Boschelli DH, Ye F, Sosa A, Mansour TS, Frost P, Wood A, Pangalos MN, Zaleska MM. Neuroprotective Profile of Novel Src Kinase Inhibitors in Rodent Models of Cerebral Ischemia. (2009). *JPET* 331:827-835
64. Guo J, Wu HW, Hu G, Han X, De W, Sun YJ. Sustained Activation of Src-Family Tyrosine Kinases by Ischemia: a Potential Mechanism Mediating Extracellular Signal-Regulated Kinase Cascades in Hippocampal Dentate Gyrus. (2006). *Neuroscience* 143:827-836.
65. Munton RP, Vizi S, Mansuy IM. The role of protein phosphatase-1 in the modulation of synaptic and structural plasticity. (2004). *FEBS Letter* 567:121-128.
66. States Ba, Khatri L, Ziff EB. Stable synaptic retention of serine-880-phosphorylated GluR2 in hippocampal neurons. (2008). *Mol Cell Neurosci* 38:189-202.
67. Li T, Chalifour LE, Paudel HK. Phosphorylation of Protein Phosphatase 1 (PP1) by Cyclin-dependent Protein Kinase 5 During Nerve Growth Factor-Induced PC12 Cell Differentiation. (2007). *JBC*.
68. O'Loughlen A, Perez-Morgado MI, Martin ME. Reversible inhibition of the protein phosphatase 1 by hydrogen peroxide. Potential regulation of eIF2a phosphorylation in differentiated PC12 cells. (2003). *Archives of Biochemistry and Biophysics* 417:194-202.
69. Dixon R.M, Mellor J.R, Hanley J.G. PICK1-mediated glutamate receptor subunit 2 (GluR2) trafficking contributes to cell death in oxygen/glucose-deprived hippocampal neurons. (2009). *JBC* 284(21):14230-14235.
70. Thorsen T.S, Madsen K.L, Rebola N, Rathje M, Anggono V, Bach A, Moreira I.S, Stuhr-Hansen N, Dyhring T, Peters D, Beuming T, Haganir R, Weinstein H, Mülle C, Stømggaard K, Rønn L.C.B, Gether U. Identification of a small-molecule inhibitor of the PICK1 PDZ domain that inhibits hippocampal LTP and LTD. (2010). *PNAS* 107(1): 413-418.
71. Bright R and Mochly-Rosen D. The Role of Protein Kinase C in Cerebral Ischemic and Reperfusion Injury. (2005). *Stroke* 36:2781-2790.

72. Minnerup J, Sutherland BA, Buchan AM, Kleinschnitz C. Neuroprotection for Stroke: Current Status and Future Perspectives. (2012). *Int J Mol Sci* 13:11753-11772.
73. Sutherland BA, Minnerup J, Balami JS, Arba F, Buchan AM, Kleinschnitz C. Neuroprotection for ischaemic stroke: Translation from the bench to the bedside. (2012). *Int J Stroke* 7:407-418.
74. Cheng YD, Al-Khoury L, Zivin JA. Neuroprotection for Ischemic Stroke: Two Decades of Success and Failure. (2004). *The Journal of the American Society for Experimental NeuroTherapeutics* 1:36-45.
75. Beske P.H. and Jackson D.A. NADPH oxidase mediates the oxygen-glucose deprivation/ reperfusion-induced increase in the tyrosine phosphorylation of the N-methyl-D-aspartate receptor NR2A subunit in retinoic acid differentiated SH-SY5Y Cells. (2012). *J Mol Sig* 7:15.