

University of Montana

## ScholarWorks at University of Montana

---

Graduate Student Theses, Dissertations, &  
Professional Papers

Graduate School

---

1985

### Structural evolution of the southeastern Scapegoat Wilderness west-central Montana

Daniel T. McDonough  
*The University of Montana*

Follow this and additional works at: <https://scholarworks.umt.edu/etd>

**Let us know how access to this document benefits you.**

---

#### Recommended Citation

McDonough, Daniel T., "Structural evolution of the southeastern Scapegoat Wilderness west-central Montana" (1985). *Graduate Student Theses, Dissertations, & Professional Papers*. 7522.  
<https://scholarworks.umt.edu/etd/7522>

This Thesis is brought to you for free and open access by the Graduate School at ScholarWorks at University of Montana. It has been accepted for inclusion in Graduate Student Theses, Dissertations, & Professional Papers by an authorized administrator of ScholarWorks at University of Montana. For more information, please contact [scholarworks@mso.umt.edu](mailto:scholarworks@mso.umt.edu).

COPYRIGHT ACT OF 1976

THIS IS AN UNPUBLISHED MANUSCRIPT IN WHICH COPYRIGHT SUBSISTS. ANY FURTHER REPRINTING OF ITS CONTENTS MUST BE APPROVED BY THE AUTHOR.

MANSFIELD LIBRARY  
UNIVERSITY OF MONTANA  
DATE: 1985



STRUCTURAL EVOLUTION OF THE SOUTHEASTERN SCAPEGOAT  
WILDERNESS, WEST-CENTRAL MONTANA

By

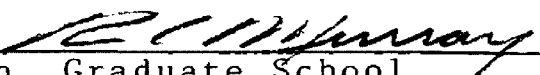
Daniel T. McDonough

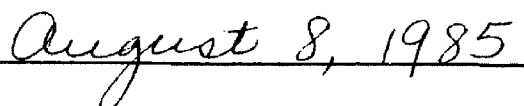
B.S., Montana State University, 1978

Presented in partial fulfillment of the requirements  
for the degree of  
Master of Science  
University of Montana  
1985

Approved by:

  
Chairman, Board of Examiners

  
Dean, Graduate School

  
Date

UMI Number: EP38323

All rights reserved

**INFORMATION TO ALL USERS**

The quality of this reproduction is dependent upon the quality of the copy submitted.

In the unlikely event that the author did not send a complete manuscript and there are missing pages, these will be noted. Also, if material had to be removed, a note will indicate the deletion.



UMI EP38323

Published by ProQuest LLC (2013). Copyright in the Dissertation held by the Author.

Microform Edition © ProQuest LLC.

All rights reserved. This work is protected against unauthorized copying under Title 17, United States Code



ProQuest LLC.  
789 East Eisenhower Parkway  
P.O. Box 1346  
Ann Arbor, MI 48106 - 1346

Structural Evolution of the Southeastern Scapegoat  
Wilderness, West-central Montana (125 pp.)

Director: Don Winston

Modern thrust belt analysis techniques were used to decipher the structural evolution of the southeastern Scapegoat Wilderness. The structural geology of the area is dominated by the Hoadley and Silver King thrust sheets, which are mostly comprised of Belt rocks. The Hoadley sheet contains two large synclines, the Continental Divide and Bighorn Creek, which result from normal and lateral hanging wall ramps respectively. The major hanging wall ramp in the Silver King thrust sheet, the Lone Mountain ramp monocline, forms the southern limb of the Heart Lake syncline and eastward is cut by the Lone Mountain normal fault. The Silver King thrust deflected upward over a Proterozoic syn-depositional basement fault, the Jocko line, to form the ramp monocline. Impingement of the ramp monocline on the Landers Fork segment paleoramp probably forced the forward propagation of the Hoadley thrust from the base of the paleoramp. Analysis of the Bighorn Creek segment of Silver King thrust revealed that the Hoadley thrust plunges southeastward beneath the Silver King thrust sheet and terminates in the southeastern Scapegoat.

Extensional faulting post-dated thrusting. All extensional faults are localized in or near thrust structures and therefore are probably listric, soling into the thrust decollement.

All structures in the southeastern Scapegoat are readily produced by a simple southwest to northeast thrust faulting and later extensional faulting sequence which is well understood in other portions of the Montana thrust and fold belt.

Dedicated to my wife Debbie, for her  
love, support, and encouragement.

## ACKNOWLEDGEMENTS

I sincerely thank Dr. Don Winston for his guidance, enthusiasm, encouragement, and critical review of my thesis. Thanks also to Dr.s Steven Sheriff and Richard Hayden for serving on my committee and reviewing the thesis. Special thanks go to Andy Mork, my more-than-able field assistant, and Dr. David Fountain for his patience and use of his lab computer for word processing. Greg Byer was an excellent office mate and supporter.

Special thanks and acknowledgement go to my parents, Russell and Dora McDonough, for a lifetime of support and encouragement, and stressing the value of education.

Support for a field assistant was provided through a MONTS grant awarded to Don Winston. Partial support for this research was provided by a UM Alumni Foundation McDonough Fund (no relation) research grant.



## TABLE OF CONTENTS

	Page
ABSTRACT	ii
ACKNOWLEDGEMENTS	iii
LIST OF TABLES	vi
LIST OF FIGURES	vii
CHAPTER	
1. INTRODUCTION . . . . .	1
Purpose and Method of Study . . . . .	1
Previous Studies . . . . .	7
2. TECTONO-STRATIGRAPHIC SETTING . . . . .	18
Tectonic Setting . . . . .	18
Lithostratigraphy . . . . .	19
Mechanical Behavior of Strata . . . . .	19
3. AREAL GEOLOGY . . . . .	22
Domain 2 - Hoadley Thrust Sheet . . . . .	22
Hoadley Thrust and Folds . . . . .	23
Extensional Faults . . . . .	27
Domain 3 - Silver King Thrust Sheet . . . . .	28
Thrust Faults and Folds . . . . .	29
Extensional Faults . . . . .	32
4. PRINCIPLES OF ANALYSIS . . . . .	34
Purpose . . . . .	34
Thrust Faults and Folds . . . . .	34

Transverse and Oblique Structures . . . . .	48
Extensional Faults . . . . .	50
Structures in the Footwall . . . . .	56
5. ANALYSIS OF STRUCTURES . . . . .	60
Purpose and Method . . . . .	60
Hoadley Thrust Sheet - Domain 2 . . . . .	60
Hoadley Thrust and Folds . . . . .	60
Extensional Faults . . . . .	72
Synthesis of Domain 2 Structure . . . . .	73
Silver King Thrust Sheet - Domain 3 . . . . .	74
Thrust Faults and Folds . . . . .	75
Extensional Faults . . . . .	76
Silver King Thrust - Bounding Segments . . . . .	80
Implications for the Hoadley Thrust . . . . .	94
Synthesis of Domain 3 Structure . . . . .	94
6. STRUCTURAL EVOLUTION MODEL . . . . .	96
Model . . . . .	97
Horizontal Displacement Implications . . . . .	101
Effects of Pre-thrusting Structure . . . . .	106
Extensional Faulting . . . . .	107
Summary of Structural Evolution . . . . .	109
7. IMPLICATIONS AND CONCLUSIONS . . . . .	111
REFERENCES CITED . . . . .	117
APPENDIX	
1. Lithologic Descriptions of Belt Units . . . . .	121

LIST OF TABLES

TABLE	Page
1. Calculated thicknesses of Belt strata in and around the study area . . . . .	9
2. Summary of the lithostratigraphy in the study area . . . . .	20

## LIST OF FIGURES

FIGURE	Page
1. Location map of study area . . . . .	2
2. Tectonic map of study area . . . . .	4
3. Location map of calculated thicknesses of Belt strata in and around the study area . . . . .	9
4. Hinged offset model proposed for the Hoadley thrust . . . . .	10
5. Bedrock geologic map of the study area . . . . .	11
6. Location map of proposed syn-depositional Proterozoic basement faults . . . . .	17
7. Formation of ramp anticlines and synclines . . . . .	36
8. Formation of asymmetric syncline . .	37
9. Structural terrace and ramp monocline . . . . .	38
10. Thrust ramp localized over basement fault . . . . .	39
11. Development of footwall and hanging wall horses . . . . .	39
12. Figure showing identical geometry resulting from folding, then faulting, or faulting then folding .	41
13. Second generation thrust fault . . .	42
14. Development of a duplex structure .	43
15. Initiation mechanisms for duplex structures . . . . .	45
16. Geometric model resulting from impingement of a ramp monocline	

on a footwall ramp . . . . .	46
17. Folds resulting from oblique slip on a tear fault . . . . .	49
18. Development of opposing transverse ramp monoclines . . . . .	51
19. Opposing transverse ramp monoclines overlain by a thrust sheet . . . . .	52
20. Syncline and reverse cross fault . .	52
21. Normal fault localized over a footwall ramp . . . . .	54
22. Extensional fault with large stratigraphic separation . . . . .	55
23. Normal fault cutting a ramp monocline . . . . .	57
24. Normal fault cutting abruptly thickening strata . . . . .	57
25. Structurally higher thrusts folded by structurally lower thrusts . . . .	58
26. Downplunge map view of the Continental Divide syncline . . . . .	62
27. Model development of the Continental Divide syncline . . . . .	63
28. Probable geometry of the structural terrace . . . . .	67
29. Internal geometry of horse . . . . .	67
30. Evaluation of extensional model for Bighorn Creek segment . . . . .	69
31. Preferred model of the Bighorn Creek syncline . . . . .	71
32. Model development of the Lone Mountain and Lookout Creek normal faults . . . . .	77
33. Steepening of the Landers Fork	

segment by displacement of the footwall horse . . . . .	82
34. Cross section showing Landers Fork normal fault joining the Landers Fork segment . . . . .	83
35. Model Cross section showing surface geology fits model of a ramp monocline impinging on a footwall ramp . . . . .	83
36. Exploded three dimensional view of development of Silver King and Hoadley thrust sheets . . . . .	88
37. Pre-erosion, pre-extension cross section through Bighorn Creek syncline and fault segment . . . . .	90
38. 3-D cartoon showing relationship between Silver King and Hoadley thrust sheets and their footwall . . . . .	91
39. Transport direction of Silver King thrust sheet if the Bighorn Creek segment is a tear fault . . . . .	93
40. Model of structural evolution of the study area . . . . .	98
41. Post-thrusting, pre-extensional faulting paleotectonic map of the study area . . . . .	102
42. Model of minimum horizontal displacement of the Silver King and Hoadley thrust sheets . . . . .	104
43. Thick stratigraphic section exposed in a structurally thin thrust sheet with ramp monoclines . . . . .	114

## CHAPTER 1

### INTRODUCTION

#### Purpose and Methods of Study

The southeastern Scapegoat Wilderness is a structurally complex portion of the west-central Montana thrust and fold belt (Fig. 1), containing two major thrust faults, the Hoadley and Silver King (new name). Within the southeastern Scapegoat the Hoadley thrust truncates the Continental Divide syncline, a regional structure which extends 120 km to the north. Another prominent fold, the Bighorn Creek syncline, trends anomalously northeastward and is truncated by both major thrusts (Fig. 2). Furthermore, Winston (1985) proposed that Laramide thrust patterns in this area are influenced by an east-west syn-depositional Proterozoic basement fault, which is reflected in abrupt stratigraphic thickness changes in Belt rocks. I chose to study the southeastern Scapegoat Wilderness to decipher its structural configuration, interpret its structural evolution, and test Winston's (1985) proposal.

Mudge et al.(1974) mapped the Scapegoat Wilderness; however, they did not explain the complicated map

Figure 1. Location map of study area in northwest  
Montana thrust and fold belt (after  
Winston et al., 1982, ms.)



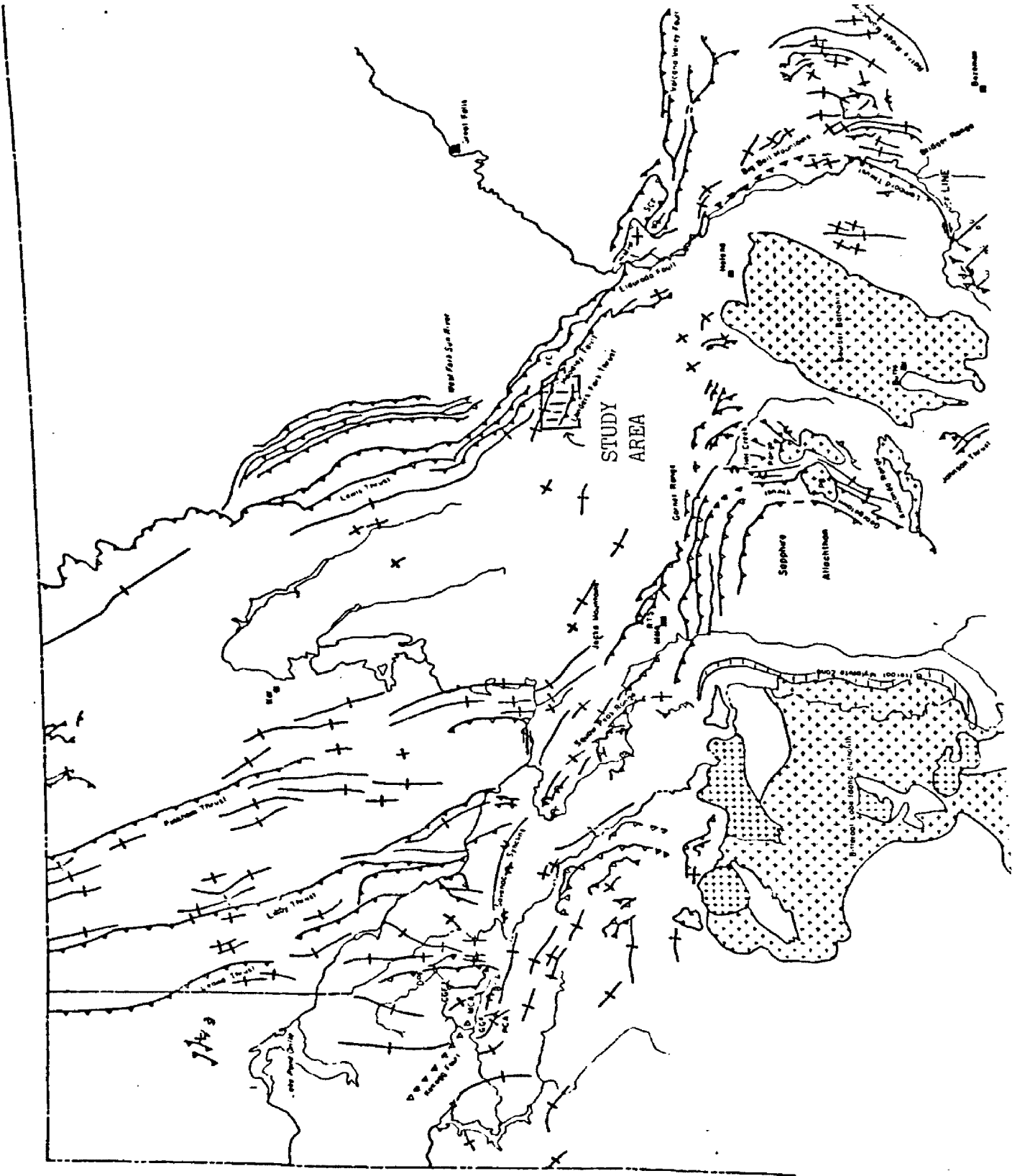
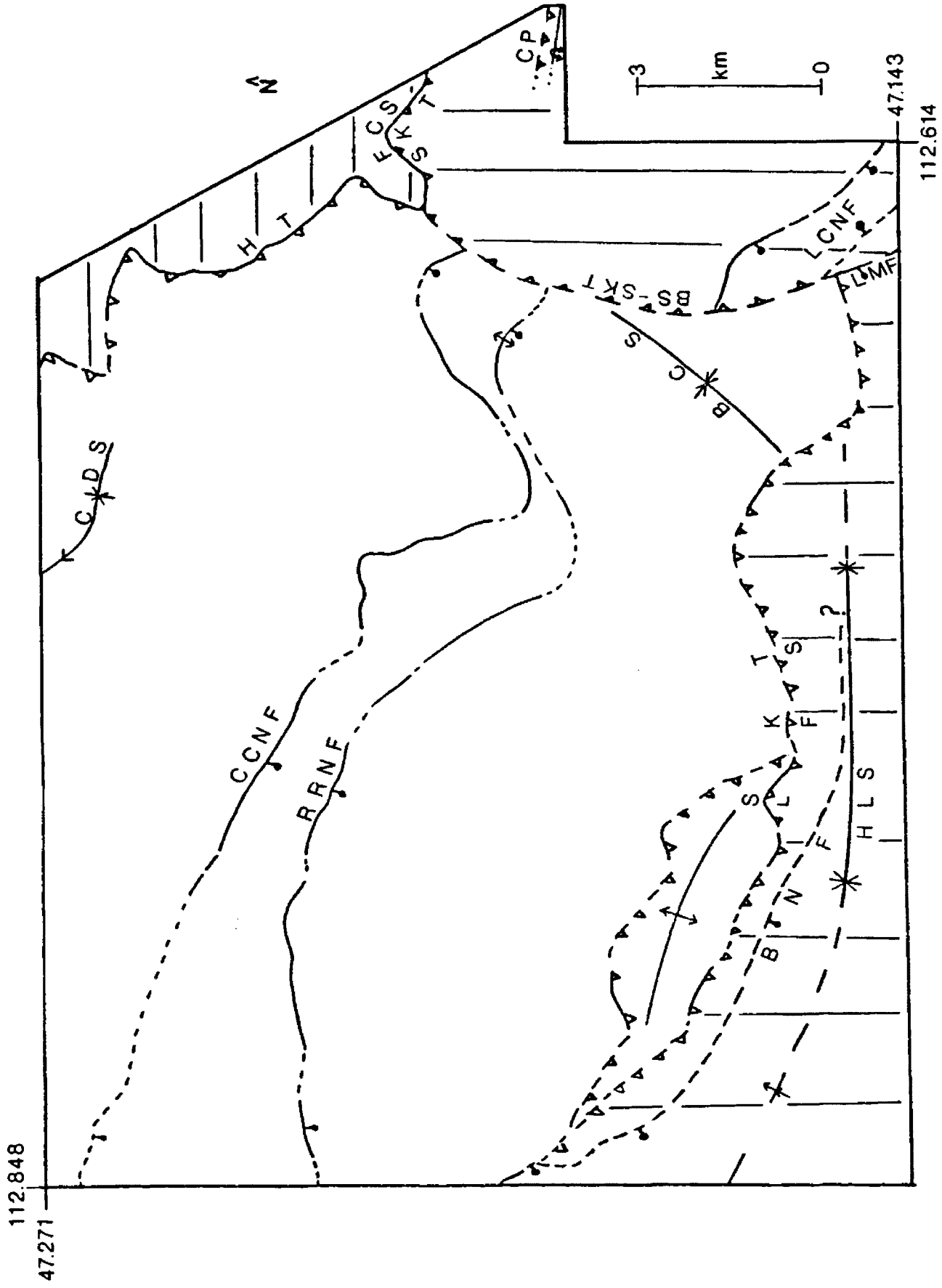


Figure 2. Tectonic map of the southeastern Scapegoat Wilderness. HT = Hoadley thrust fault, FCS, BS, and LFS = Falls Creek, Bighorn Creek, and Landers Fork segments of the Silver King thrust (SKT), CCNF = Cooney Creek normal fault, RRNF = Red Ridge normal fault, LCNF = Lookout Creek normal faults, LMF = Lone Mountain normal fault, BNF = Blackfoot normal fault, CDS = Continental Divide syncline, CP = Caribou Peak thrust and anticline, BCS = Bighorn Creek syncline, HLS = Heart Lake syncline. Footwall domain is horizontally lined, Silver King thrust sheet vertically lined, and Hoadley thrust sheet unlined.



patterns of the structures in the southeastern portion. I remapped 270 sq km of the southeastern Scapegoat Wilderness during the summer of 1982, and from my mapping have interpreted the structural evolution of the area.

The purpose of this thesis is to present a geologically reasonable interpretation of the structural evolution of this complex area using surface geology and modern "rules" of thin-skinned thrust belt geometry as constraints. To do this, I first describe the tectono-stratigraphic setting and areal geology of the southeastern Scapegoat Wilderness. I then present selected principles of analysis in which some "rules" of thrust belt geometry are reviewed along with structures possible within the bounds of these rules. Then, using these "rules" and possible structures as models, I analyze the structures within the southeastern Scapegoat. Finally, I present a synthesis of the structural evolution of the southeastern Scapegoat which is based on the results of this analysis. The most significant finding of this analysis is that the Hoadley thrust plunges beneath the Silver King thrust sheet and ends within the southeastern Scapegoat. As a consequence, the structural history of the Hoadley thrust sheet is reinterpreted.

## Previous Studies

Geological and geophysical studies of the Scapegoat Wilderness and surrounding area include Walcott (1906, 1908, 1910), Clapp and Deiss (1931), Clapp (1932, 1934), Deiss (1933, 1939, 1943), Sloss and Laird (1946), McGill and Sommers (1967), Mudge et al.(1968), Funk (1967), Mudge (1970), Mudge et al.(1974), Earhart et al.(1977), Mudge and Earhart (1980), Winston et al.(1982, ms), Mudge et al.(1983) and Winston (1985). Several of these studies are pertinent to this thesis. Clapp (1932) initially mapped the Scapegoat and recognized, but did not name, the Hoadley thrust, which was named by Deiss (1943). Clapp, Deiss, and all subsequent studies until this one, interpreted the Silver King thrust as a continuation of the Hoadley fault.

McGill and Sommers (1967) described the Belt strata in the northern part of the Scapegoat Wilderness. They identified in the area the Snowslip, Shepherd, Mount Shields, Bonner, McNamara, and Garnet Range formations of the Missoula Group. They also demonstrated southwestward stratigraphic thickening of the Belt strata.

Although no previous studies have analyzed the structural development of the southeastern Scapegoat, several studies have included the area in discussions of regional structure. Mudge et al.(1974, p.B24) described the structural geology of the Scapegoat as "moderately complex", but provided no analysis of it. They also recognized the large Belt stratigraphic thickness differences across the Silver King thrust ( Fig.3, table 1). Mudge and Earhart (1980) proposed that the Hoadley thrust is hinged (Fig. 4), with horizontal displacement increasing from zero 30 km north of the study area, to 38 km in the study area, to a maximum of 70 km at the southern end of the fault. However, they extended the Hoadley to include the Silver King thrust, which ends south of Rogers Pass. They named the Continental Divide syncline and noted its truncation by the Hoadley. Winston et al.(1982, ms) noted the structural terrace topped by Mount Shields which dominates the central portion of the map area (Fig. 5). They also proposed the Landers Fork segment formed before, and was cut by, the Hoadley thrust. Furthermore, they proposed that Laramide structures reflect the trend of a Proterozoic syn-depositional basement fault (Fig. 6).

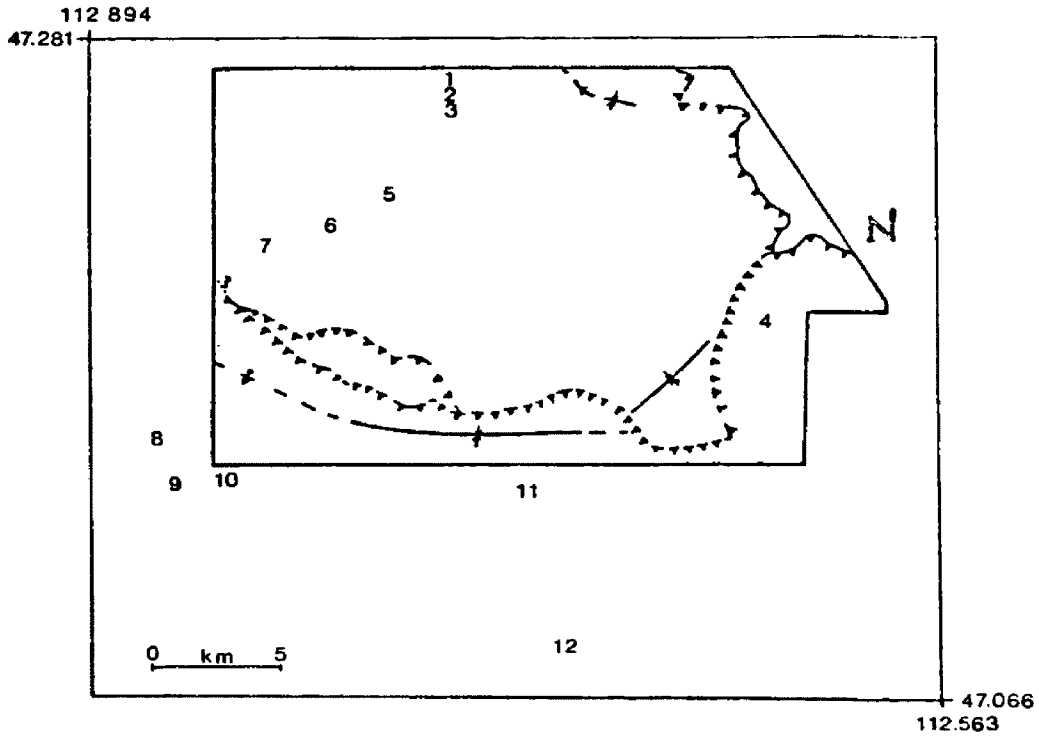


Figure 3. Location of measured thicknesses of Belt strata in and around the study area. Thickness values given in table 1.

Table 1  
Thicknesses of Belt stratigraphic units in and around the study area. Locations are on figure 3.

Formation	Thickness (m)	Location
Bonner Quartzite	443	1
	487*	8
Mount Shields Fm.	616	2
	780	5
	1859*	8
Shephard Fm.	492	3
	523	6
	716*	9
Snowslip Fm.	546	7
	1097*	10
Helena Dolomite	800**	4
	1661*	11
Empire-Spokane Fms.	2614*	12

All thicknesses measured from maps.

\* From Mudge et al., 1974

\*\* Calculated from map by Mudge et al., 1974

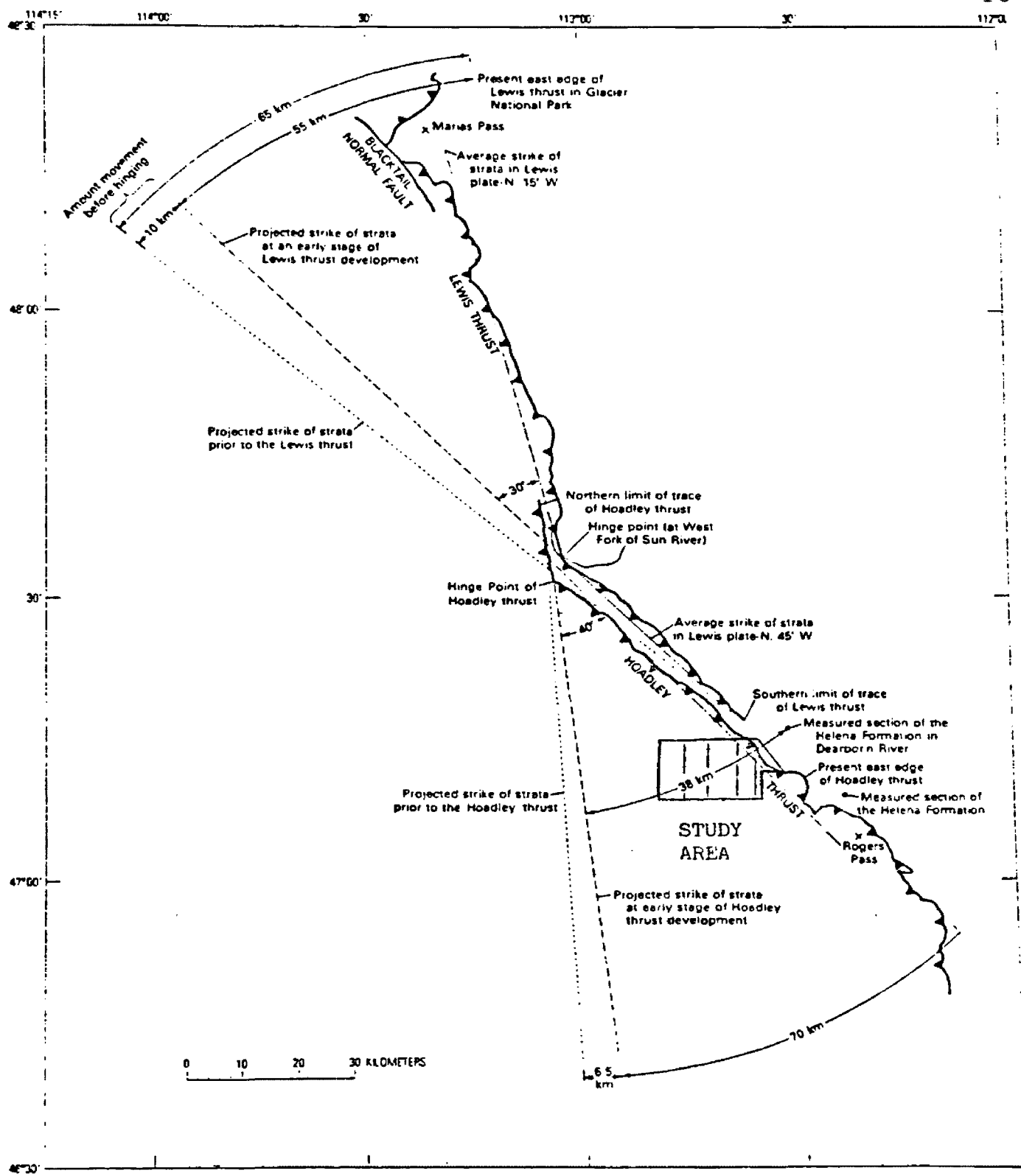

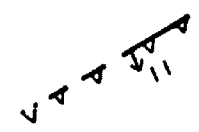
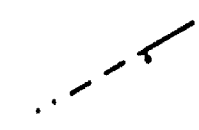

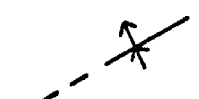

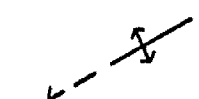

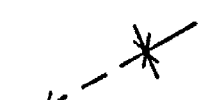



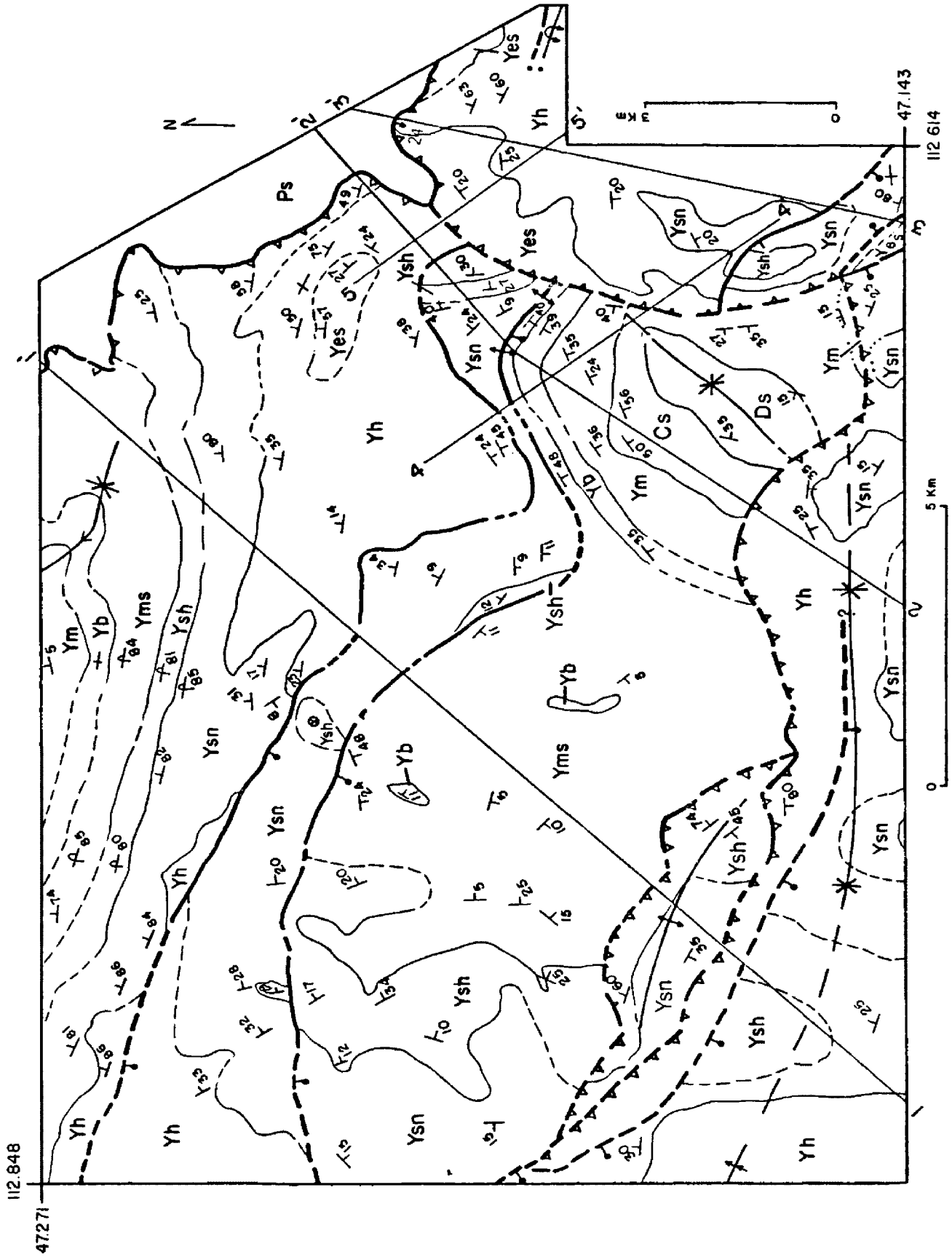
Figure 4. Hinged offset model proposed for the Hoadley thrust (from Mudge and Earhart, 1980).

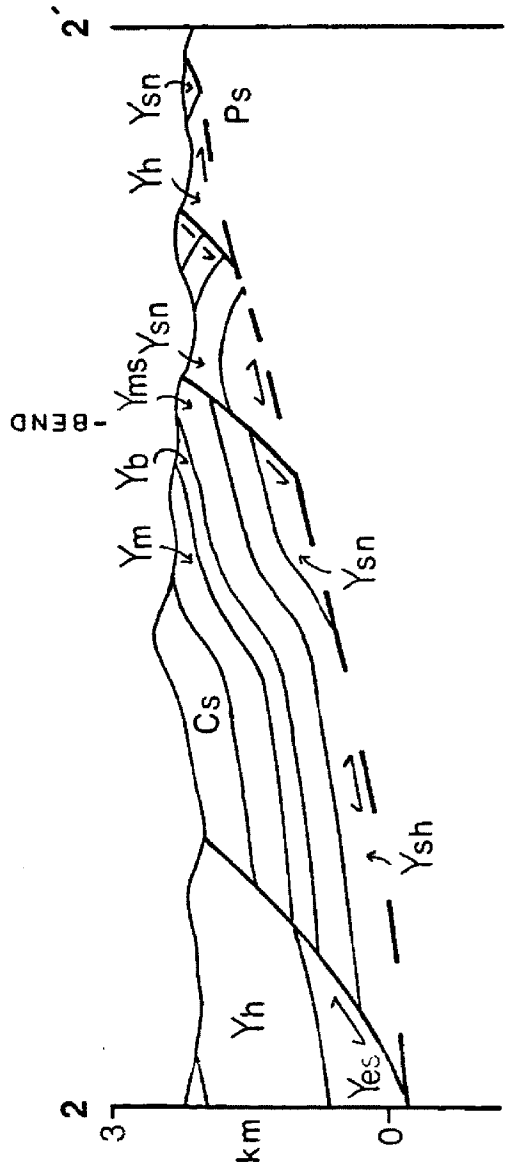
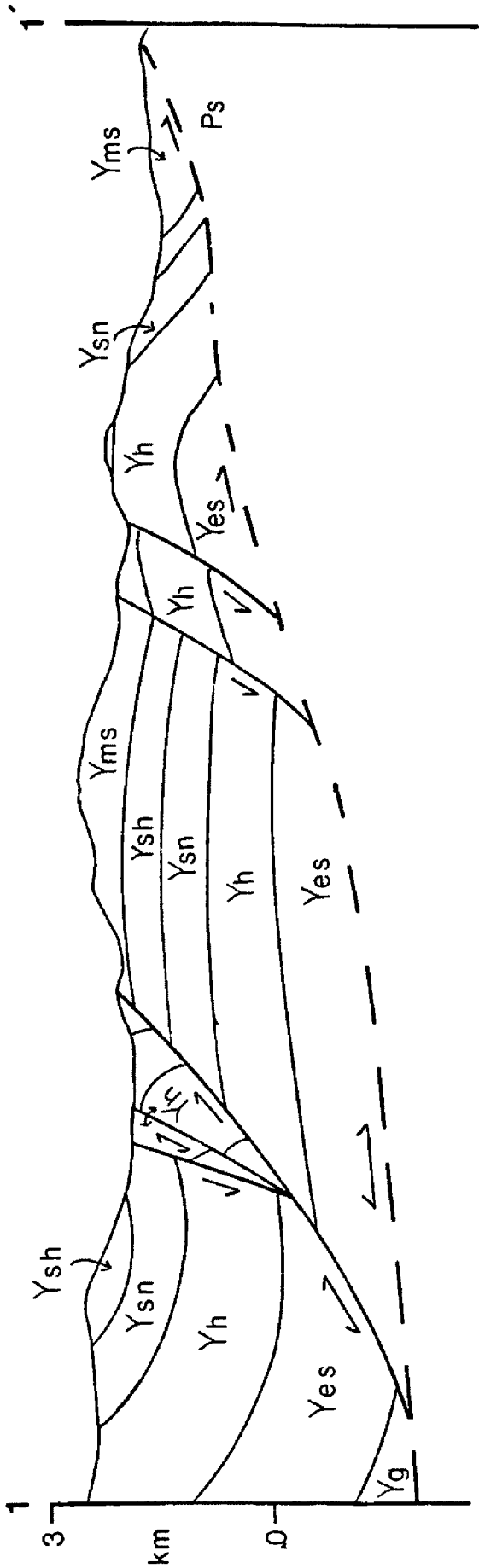


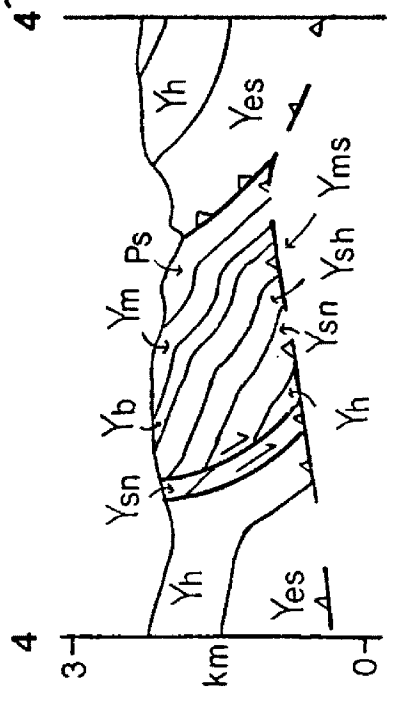
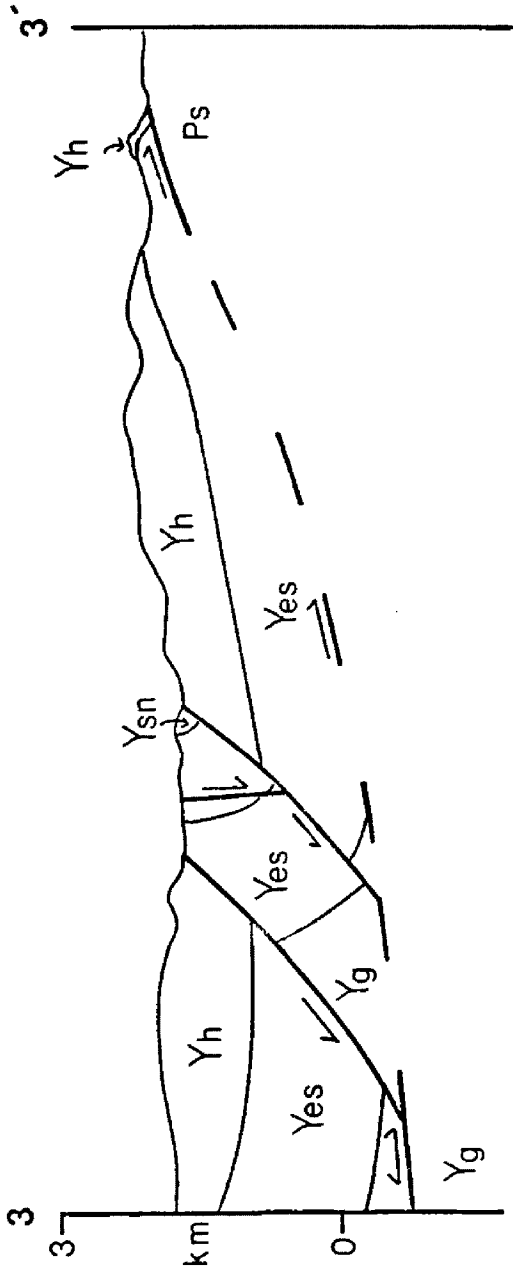
Figure 5. Bedrock geologic map of the southeastern Scapegoat Wilderness with cross sections. Sources: McDonough, 1982, unpublished mapping; Mudge et al., 1974. Base from U.S. Geological Survey Coopers Lake, 1900; Ovando, 1902; and Saypo, 1905; 1:125000 maps; after Mudge et al., 1974. Cross section 3-3' extended 4 km south of map area to clarify structure. Surface geology of extension by Mudge et al.(1974).

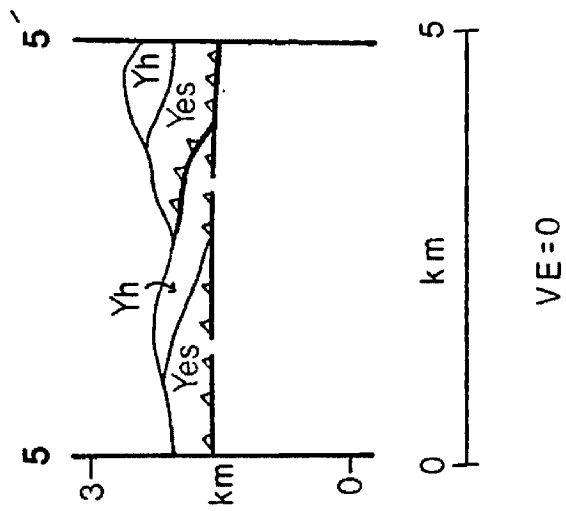
### MAP EXPLANATION

	ROCK UNITS		LINE SYMBOLS
	<b>Ms</b> Mississippian Sed. Rocks	<div style="font-size: 2em;">}</div> <b>Ps</b> Paleozoic Sed. Rocks	Dashed where approximately located, dotted where inferred
	<b>Ds</b> Devonian Sed. Rocks		
	<b>Cs</b> Cambrian Sed. Rocks		
<div style="font-size: 2em;">[</div> Precambrian Y	<b>Ym</b> McNamara Fm.		 Contact
	<b>Yb</b> Bonner Quartzite		 Thrust fault, showing dip, teeth on upper plate
	<b>Yms</b> Mount Shields Fm.	STRIKE AND DIP OF BEDS	 Normal fault, ball on downthrown side
	<b>Ysh</b> Shephard Fm.	 Strike and dip	 Monocline
	<b>Ysn</b> Snowslip Fm.	 Overtaken beds	 Anticline, showing plunge direction
	<b>Yh</b> Helena Dolomite	 Vertical beds	 Syncline, showing plunge direction
	<b>Yes</b> Empire-Spokane Fms.	 Horizontal beds	
<b>Yg</b> Greyson Fm.			









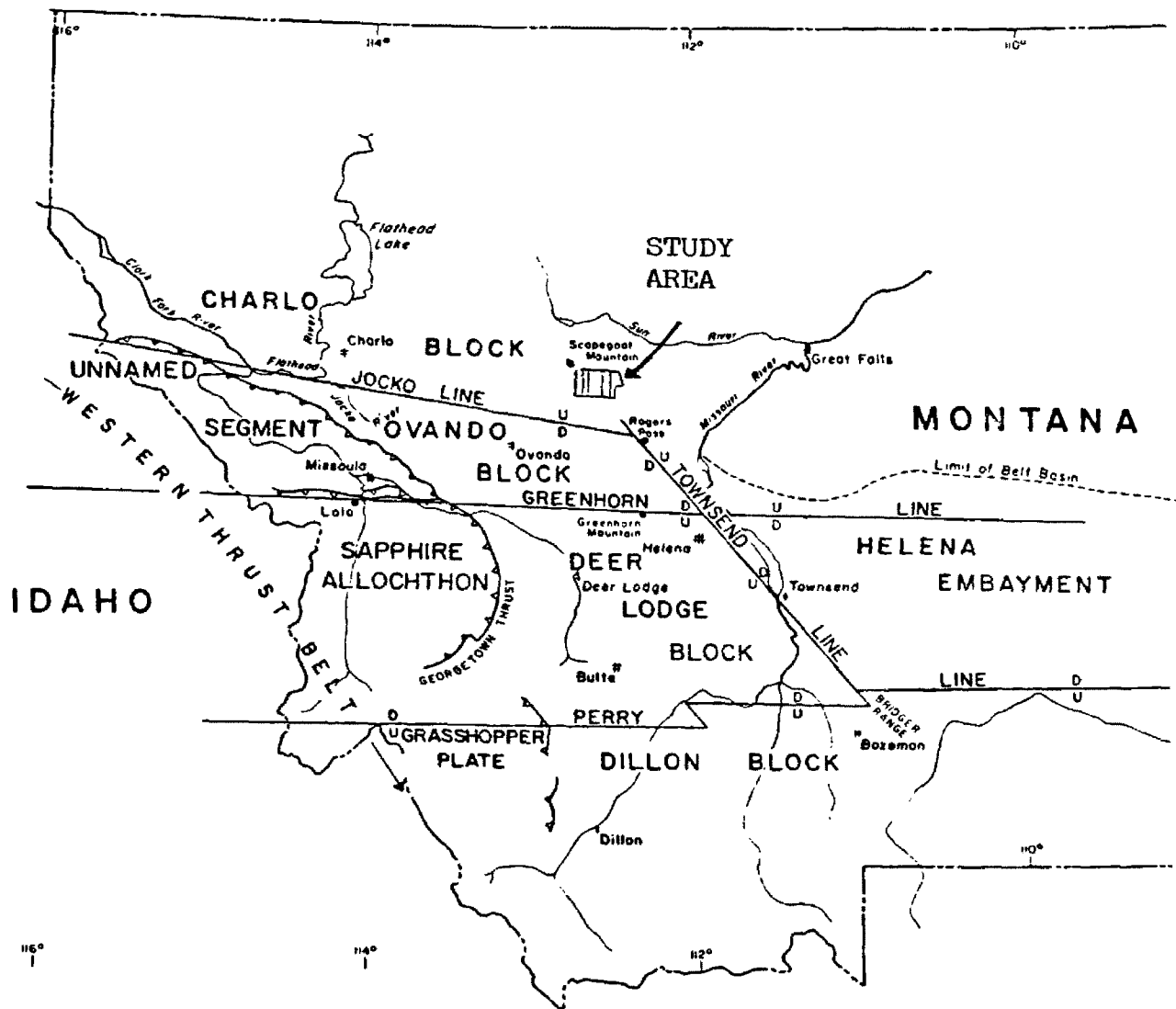


Figure 6. Location map of proposed syn-depositional Proterozoic basement faults (after Winston et al., 1982, ms.)

CHAPTER 2  
TECTONO-STRATIGRAPHIC SETTING

Tectonic Setting

The southeastern Scapegoat Wilderness lies in the eastern portion of the Cordilleran thrust and fold belt (Fig. 1). The Hoadley and Silver King thrusts in the northeastern part of the study area mark the transition between the closely spaced thrust faults and folds of the Montana disturbed belt (Mudge, 1970) to the northeast, and the broad open folds and widely spaced faults of the thrust and fold belt, mostly developed within Belt strata in the study area. The eastern portion of the Cordilleran thrust and fold belt developed from late Cretaceous to late Paleocene time in northwest Montana (Hoffman et al., 1976). Cenozoic extensional faulting began in the Miocene and continues today (Smith and Sbar, 1974). Although structures in the southeastern Scapegoat were not dated directly, the structural development of the area is compatible with this time framework.



## Lithostratigraphy

The southeastern Scapegoat Wilderness contains Middle Proterozoic Belt Supergroup argillite, siltite, quartzite, and dolomite; lower and middle Paleozoic dolomite, limestone, sandstone, and shale; and Quaternary glacial deposits and alluvium. The lithostratigraphy of the Proterozoic and Paleozoic rocks is summarized in table 2. More complete lithologic descriptions of the Belt strata are in appendix 1. I used the same Belt stratigraphic nomenclature for the study area as Mudge et al.(1974). The Paleozoic formations were grouped together and mapped as Cambrian, Devonian, and Mississippian sedimentary rock packages. All Belt units in the study area, except the McNamara, thicken abruptly southwestward (table 1) (Mudge et al., 1974). The Quaternary units fill the drainages and obscure the bedrock geology in these areas.

## Mechanical Behaviour of the Strata

The rocks within the southeastern Scapegoat responded to tectonism with three distinct, lithologically dependent styles of deformation. The Belt clastic units behaved competently, forming

TABLE 2

		Rock Unit	Lithology
MISS.		Castle Reef Dolomite	dolomite, dolo. limestone
		Allan Mt. Limestone	limestone
		Three Forks Formation	limestone, dolomite, shale
DEV.		Jefferson Formation	dolomite, dolo. limestone
		Maywood Formation	dolo. mudstone, limestone
CAMBRIAN		Devils Glen Dolomite	dolomite
		Switchback Shale	mudstone
		Steamboat Limestone	limestone
		Pagoda Limestone	limestone
		Dearborn Limestone	limestone
		Damnation Limestone	limestone
		Gordon Shale	mudstone
		Flathead Sandstone	quartz sandstone
PRECAMBRIAN Y Belt Supergroup	Missoula Group	McNamara Fm.	quartzite, siltite, argillite
		Bonner Quartzite	quartzite
		Mount Shields Fm.	quartzite, siltite
		Shephard Fm.	silty dolomite, dolo. siltite
		Snowslip Fm.	argillite, siltite, quartzite
		Helena Dolomite	silty dolomite, dolo. siltite
		Empire & Spokane Fms.	siltite, quartzite
Greyson Fm.	siltite, argillite		

incoherent breccias of dominantly cobble sized clasts in fault zones, and in some places fracturing in the fold limbs. The Belt carbonate rock units, the Helena and Shepherd formations, behaved somewhat less competently. They are not fractured, thinned, or thickened in folds, and therefore deformed by flexural slip folding. In fault zones they form incoherent breccias of dominantly pebble and some cobble sized clasts. In some places near fault zones the Helena and Shepherd form chaotic mesoscopic folds. The Paleozoic carbonates and shales behaved the least competently. Below the Silver King fault they chaotically folded and in some places transformed into zones of fault gouge less than 1 m thick.

Except for faulting, the rocks in the southeastern Scapegoat behaved coherently. Penetrative cleavage and in situ slickensides were not found, although White (1980) reported slickensides, but no penetrative cleavage north of the Scapegoat Wilderness

## CHAPTER 3

### AREAL GEOLOGY

The study area is divided into three fault-bounded structural domains, each having a characteristic internal stratigraphic sequence and structural style (Fig. 2). Domain 1 forms the footwall rocks of the Hoadley and Silver King thrust sheets. These rocks are tightly folded and faulted lower and middle Paleozoic strata. Domain 1 marks the northeastern boundary of the mapped area, so rocks of this domain were not analyzed structurally. I refer the reader to Mudge (1970), Mudge et al.(1977), and Earhart et al.(1977) for discussion of the rocks and structures in it. Domains 2 and 3 are southwest of domain 1, structurally lie on it, and comprise portions of the Hoadley and Silver King thrust sheets respectively (Fig. 2).

#### DOMAIN 2 - THE HOADLEY THRUST SHEET

##### Description

Domain 2 is areally the largest domain and extends across the northern and central portion of the study area (Fig. 2). It also comprises the southeastern part

of the Hoadley thrust sheet. Empire-Spokane through Devonian strata outcrop in domain 2, but Missoula Group rocks are most numerous. The Hoadley thrust sheet forms the hanging wall of the Hoadley thrust, extends north and west beyond the map area, and is bounded on the south and east by the Landers Fork and Bighorn Creek segments of the Silver King thrust. Major structures within domain 2 are the Continental Divide and Bighorn Creek synclines, and the Cooney Creek and Red Ridge normal faults.

### Hoadley Thrust and Folds

#### Hoadley Thrust Fault

The Hoadley thrust fault enters the northeastern portion of the study area with an average strike of N40W until it bends southward and plunges beneath the Silver King thrust (Fig. 2). It dips beneath domain 2 at 25 SW, but the dip varies, increasing to 50 northwest of the study area (Mudge et al., 1974). The thrust juxtaposes Belt strata on Paleozoic strata. The trace of the thrust cuts downsection in the hanging wall from within the Mount Shields at the northern boundary of the thesis area to within the Helena Dolomite at the Silver King thrust (Fig. 5).

The amount and direction of displacement of the Hoadley thrust sheet in domain 2 are not well constrained. Mudge and Earhart (1980) proposed that the Hoadley thrust is hinged to the north and that hanging wall rocks were rotated through an arc, first east-northeastward, then northeastward as displacement of the thrust sheet progressed (Fig. 4). This interpretation was based on progressively increasing estimates of horizontal displacement of the thrust sheet southward. However, because these estimates assumed a uniform southwestward stratigraphic thickening rate within the Helena Dolomite, the interpreted southward increase in thrust displacement may be in error. Eby (1977) has shown that the Helena thickens abruptly southward within the Eldorado thrust sheet from 123 m at Falls Creek to 492 m at Rogers Pass. Some minimum displacement estimates based on the structural evolution model are presented below.

#### Continental Divide Syncline

The Continental Divide syncline is a regional structural feature, extending 120 km from the southeastern Scapegoat to its northern terminus near Marias Pass at the southern tip of Glacier National Park (Mudge and Earhart, 1980). The syncline's terminus in

the southeastern Scapegoat is marked by a change in strike of the strata from west-northwest to south-southwest, at which point the strata are truncated by the Hoadley thrust (Fig. 5). Within the study area, the trend of the syncline changes from N 75 W at its southern terminus to N 40 W at the northern boundary of the map area. The syncline is an asymmetric broad open fold that verges northeastward. Helena through Mount Shields strata outcrop in the slightly overturned southern limb. The northeastern limb contains Mount Shields through McNamara strata and dips approximately 25 SW (Mudge et al., 1974).

#### Structural Terrace

The structural terrace in the central portion of domain 2 (Fig. 2) was first noticed by Winston et al. (1982, ms). The terrace is bounded by the Continental Divide syncline on the north, the Bighorn Creek syncline on the east, the rejoining splay of the Landers Fork segment on the south, and continues westward beyond the map. The terrace gently plunges to the east, with Snowslip outcropping in the west and Mount Shields at its eastern edge before the strata dip steeply into the western limb of the Bighorn Creek syncline (Fig. 5).

### Rejoining Splay and Horse

The Landers Fork segment and a rejoining thrust splay bound a horse containing Twin Lakes in the southern portion of the map area (Fig. 5). Snowslip and Shephard are exposed in the horse and warped into a west-northwest - east-northeast trending anticline. The horse is included with the Hoadley thrust sheet because strata within the horse are in map continuity with strata across the splay, indicating the splay has minor offset. Three point solutions yielded an average surface dip of 45 SSW for the splay.

### Bighorn Creek Syncline

The Bighorn Creek syncline is a prominent cross fold in the southeastern portion of the map area (Fig. 2). The syncline trends N45E, is asymmetric, and verges southeast. The northwest limb has an average dip of 55 SE and the southeast limb 22 NW. The syncline is truncated on the northeast and southwest by the Bighorn Creek and Landers Fork segments of the Silver King thrust respectively. The prominent widening map pattern of the McNamara formation in the northwest limb of the syncline (Fig. 5) is a topographic effect caused by a resistant sand lense (see appendix 1 for a lithologic description). Mount Shields through Devonian strata



outcrop in the syncline.

## Extensional Faults

### Cooney Creek Normal Fault

The Cooney Creek normal fault is internal to the Hoadley thrust sheet (Fig. 2), and has stratigraphic separation of at least 555 m where Helena is juxtaposed against Mount Shields at the fault's eastern end (Fig. 5). The eastern segment of the fault parallels the northern limb of the Bighorn Creek syncline, then veers northwestward (N40W) and follows the southern limb of the Continental Divide syncline. Offset of the fault reduces to zero 3 km west of the study area (Mudge et al., 1974). The fault has a curving trace that is not deflected by topography, implying the fault surface is high angle and not planar near the surface, and making three point dip solutions indeterminate. The fault is possibly listric.

### Red Ridge Fault

The Red Ridge fault nearly parallels the eastern segment of the Cooney Creek fault from the Bighorn Creek segment to the center of the map area, then diverges southwestward and joins, or is truncated by the Landers

Fork segment 4 km west of the map boundary (Mudge et al., 1974). Stratigraphic separation across the Red Ridge fault reaches at least 450 m where Mount Shields is juxtaposed against Snowslip. The average dip of the fault derived from two three point solutions taken in the central part of the map area is 69 south. Like the Cooney Creek fault, the Red Ridge fault could be listric at depth. The eastern segment of the Red Ridge fault marks the axis of a small anticline located along the northern limb of the Bighorn Creek Syncline (Fig. 5).

### DOMAIN 3 - THE SILVER KING THRUST SHEET

#### Description

The Silver King thrust sheet forms the hanging wall of the Silver King thrust and extends beyond the map area to the east, south, and southwest (Fig. 2). It lies structurally on domain 1 along the Falls Creek segment and on the Hoadley thrust sheet along the Landers Fork and Bighorn Creek segments. Empire-Spokane and Helena strata are exposed throughout much of domain 3, Missoula Group strata form smaller patches. Belt strata are much thicker south of the Landers Fork segment and Lone Mountain normal fault than to the north (Fig. 3, table 1). Domain 3 is internally less

deformed than domain 2, having only one prominent syncline, the Heart Lake, two major extensional faults, the Blackfoot and Lone Mountain, and several small structures.

### Thrust Faults and Folds

#### Silver King Thrust

Falls Creek Segment. - The Falls Creek Segment extends from the headwaters area of Bighorn Creek southeastward probably as far as the Helena Valley. This fault appears on most maps (Mudge et al., 1974; Earhart et al., 1977; Mudge et al., 1983) as the southeastward continuation of the Hoadley fault. Only the northern 3 km of the segment reaches into the Scapegoat map area (Fig. 2). Here, the segment trends approximately N45W, but veers southwestward where it joins the Bighorn Creek segment (Fig. 2). At this juncture, Empire-Spokane soles the thrust sheet, eastward the fault cuts upsection to within the Helena Dolomite, then downsection to again juxtapose Empire-Spokane onto lower Paleozoic rocks near the eastern boundary of the map area (Fig. 5). Along the segment, the sole of the thrust sheet is much less deformed than Paleozoic strata below the thrust. Where

Helena forms the hanging wall, the fault surface dips 24 southwest (Fig. 5). The direction and amount of displacement of the Silver King thrust sheet are not well constrained. Mudge and Earhart (1980) interpreted the Falls Creek segment as a continuation of the Hoadley thrust, therefore their estimate of thrust displacement and displacement direction needs revision. From arguments presented below, the minimum horizontal displacement of the Silver King thrust sheet is 16 km.

Bighorn Creek Segment. - The Bighorn Creek segment bounds the southeastern corner of the Hoadley thrust sheet and extends for 8 km across the eastern portion of the study area, from the intersection of the Hoadley thrust with the Falls Creek segment on the north to the Landers Fork segment and Lone Mountain normal fault on the south (Fig. 2). It has an arcuate surface trace, striking N20W in the south and N25E in the north. The segment truncates Helena through Cambrian strata in the footwall and Helena and Empire-Spokane in the hanging wall (Fig. 5). Stratigraphic separation along this segment reaches 2000 m where Cambrian strata are juxtaposed against Empire-Spokane. The segment also truncates the Cooney Creek and Red Ridge normal faults of the Hoadley thrust sheet, and the Lookout Creek normal faults of the Silver King thrust sheet (Fig. 2).

The surface trace of the Bighorn Creek segment is buried beneath the alluvium and glacial till of the Bighorn Creek drainage.

Landers Fork Segment. - The Landers Fork segment has an average trend of N60W and extends 16 km across the Scapegoat area, forming the southern boundary of the Hoadley thrust sheet (Fig. 2). Stratigraphic separation reaches 4500 m across its eastern portion, where Helena is juxtaposed against Devonian strata (Fig. 5). Three point solutions yielded an average surface dip of 82 SSW for the Landers Fork segment. From arguments presented below, the differential horizontal displacement across the segment is 8 km.

#### Caribou Peak Thrust and Anticline

The Caribou Peak thrust and anticline, first mapped by Funk (1967), are an east-west trending bedding plane thrust fault and hanging wall anticline within the Helena Dolomite that are south of, and parallel the Falls Creek segment (Figs. 2 and 5). Displacement on the bedding plane thrust is unknown, but inferred to be small because the thrust and anticline die out abruptly along strike to the west. The amplitude of the fold is less than 300 m.

### Heart Lake Syncline

The Heart Lake syncline is a broad open north-northeastward verging fold (Fig. 2) that has Helena and lower Missoula Group strata exposed in it. The syncline becomes a north-dipping monocline near the west edge of the map area and is truncated by the Landers Fork segment on the east (Fig. 5). Dips are moderate in its southern limb and moderate to steep in its northern limb.

### Extensional Faults

#### Blackfoot Normal Fault

The Blackfoot normal fault is south of and parallels the Landers Fork segment (Fig. 2). It is southside-down, strikes N60W, and stratigraphic separation reaches 1700 m where Shephard is juxtaposed against Helena. Offset on the fault decreases to zero at its eastern termination in the south-central portion of the map. Westward, the fault joins with the western extension of the Landers Fork thrust fault where the combined faults take on normal offset (Mudge et al., 1974).

### Lone Mountain Normal fault

The Lone Mountain normal fault is southwest side down, juxtaposes Helena against Empire-Spokane, and trends N30W from its intersection with the Bighorn Creek and Landers Fork segments (Fig. 2). The fault has a more westerly strike east of the map area (Earhart, 1977). Because the stratigraphic level of the Helena was not determined in the field, displacement across the fault is not constrained.

### Lookout Creek Faults

Mudge et al. (1974) mapped the Lookout Creek normal faults. They are sub-parallel to and lie slightly north of the Lone Mountain normal fault (Fig. ). The Lookout Creek faults are truncated on the west by the Bighorn Creek fault segment and join the Lone Mountain normal fault east of the map. They form an antithetic pair. The northern fault is high angle, southside-down, and has approximately 80 m vertical separation. It juxtaposes Shephard against Snowslip and Snowslip against Helena. The southern fault is mostly covered (Mudge et al., 1974), down to the north, and juxtaposes Helena against Helena.

CHAPTER 4  
PRINCIPLES OF ANALYSIS

Purpose

Dahlstrom (1970) has shown the Canadian foreland thrust and fold belt to be composed of a limited suite of structures, and that basic "rules" can be used to decipher the development of these structures. In a similar way, rules and structures that apply to the structural evolution of the southeastern Scapegoat are discussed in this section, which is largely a review and, in some cases, an extension of concepts presented by Dahlstrom (1970), Boyer (1978), and Boyer and Elliot (1982). I present the rules, develop general structures from them, then address specific cases or modifications of structures that apply to this study.

Thrust Faults and Folds

Thrust faults cut upsection in the direction of movement, usually cutting steeply upward through competent strata and nearly paralleling bedding planes in incompetent strata (Rich, 1934; Wilson and Stearns, 1958; Price, 1965; Dahlstrom, 1970; Boyer and Elliot,



1982). Transport of a thrust sheet forms anticlines where strata are repeated over the tops of the ramps (Fig. 7) and synclines between ramp anticlines (Fig. 7). Asymmetric synclines that verge toward the foreland can result from a ramp anticline riding up a hinterland sloping thrust surface (Fig. 8). In thrust sheets with large horizontal transport, hanging wall anticlines may be distant from their corresponding footwall ramps and consequently expressed as rootless "half anticlines" or "ramp monoclines" (Fig. 9). In some places ramps form above normal faults that have uplifted crystalline basement blocks (Fig. 10) which acted as buttresses. Thomas (1983) proposed that thrust ramps in the southern Appalachians are focused in this manner. Wiltschko and Eastman (1983) discussed how uplifted basement blocks concentrate compressional stress in strata overlying the bounding normal faults.

Horses, which are fault bounded bodies of rock caught in fault zones, commonly develop along ramps by splays in either footwalls or hanging walls (Fig. 11). A laterally rejoining thrust splay can outline a horse in map view. However, where erosion has cut through the thrust and splay it is usually impossible to tell whether the two rejoined above, forming a true horse (Boyer and Elliot, 1982).

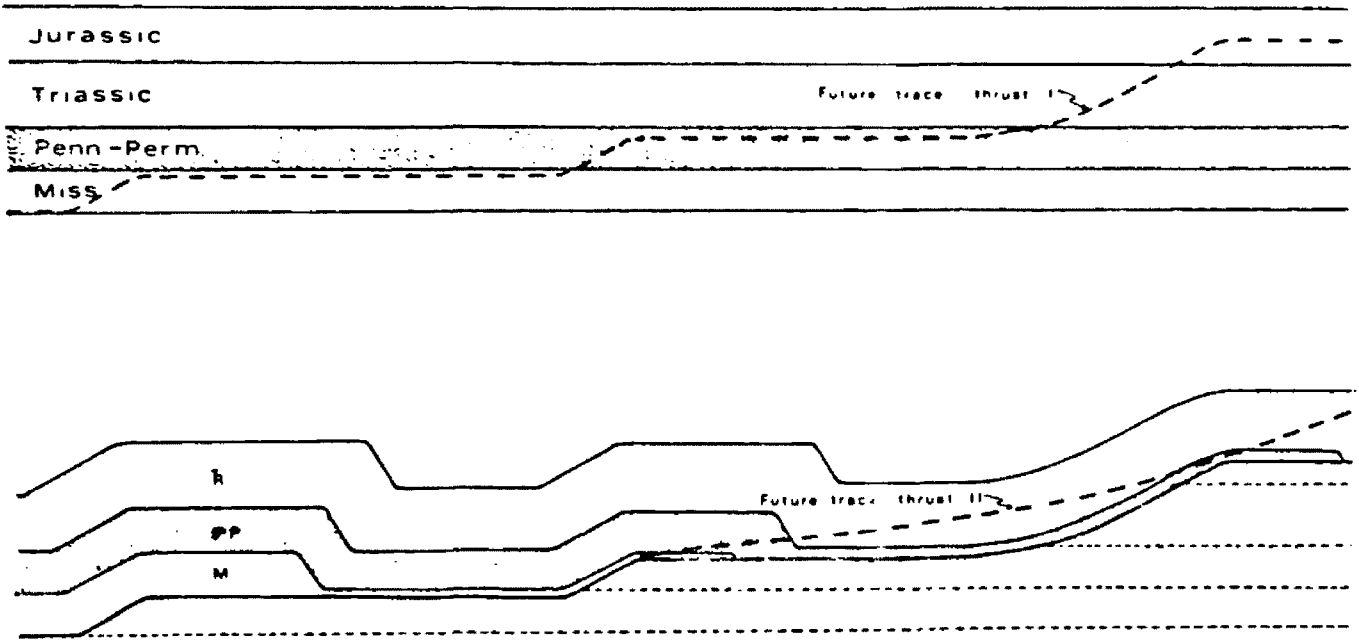


Figure 7. Three ramp anticlines with intervening synclines (from Allmendinger, 1981).

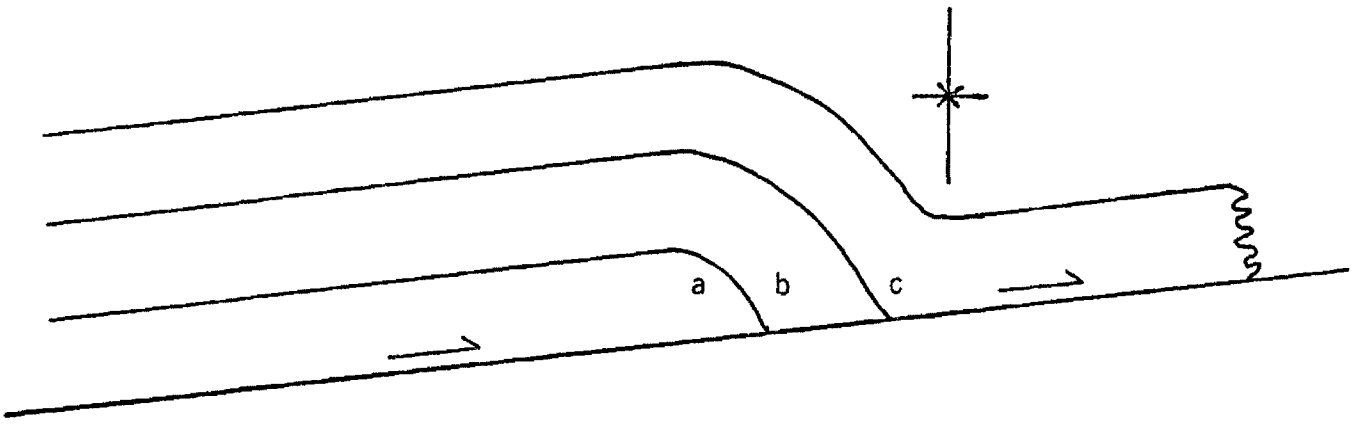
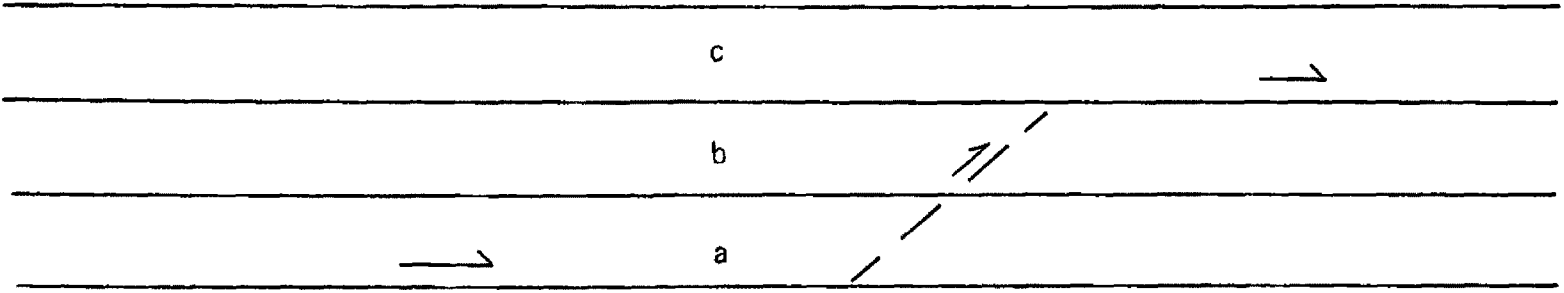


Figure 8. Development of an asymmetric syncline by transport of a thrust sheet onto a hinterland dipping glide surface.

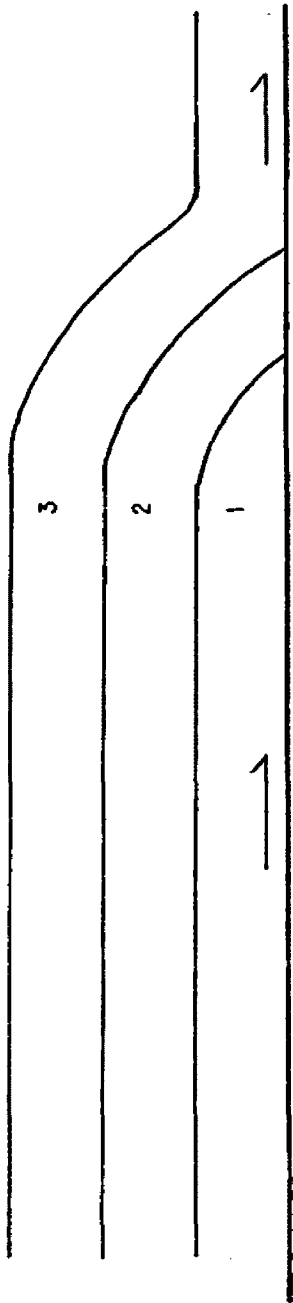


Figure 9. Structural terrace and ramp monocline in a thrust sheet.

Figure 10. Thrust ramp in sedimentary strata localized over basement fault.

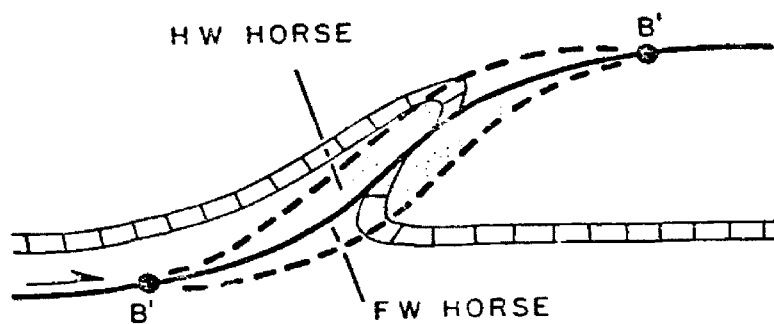
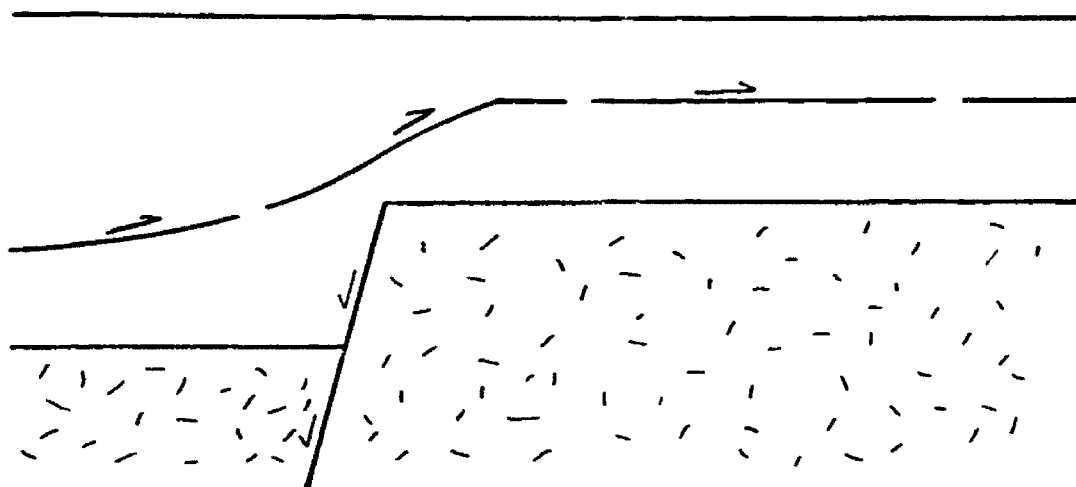


Figure 11. Development of a horse in the hanging wall or footwall of a thrust ramp (from Boyer and Elliot, 1982).

Whether thrust faulting precedes folding or folding precedes thrust faulting is usually impossible to discern from the hanging wall alone, since either sequence can produce identical structures in it (Fig. 12). A special case where thrusts clearly follow folding occurs where a second order thrust fault cuts folds previously developed over an older fault surface (Fig. 13). These faults commonly juxtapose younger strata over older strata (Dahlstrom, 1970; Allmendinger, 1981).

One method of transferring thrust slip from a lower to a higher structural level is to develop duplex structures, which are commonly expressed as structural culminations in overlying strata (Dahlstrom, 1970; Boyer and Elliot, 1982). A duplex begins forming when a new thrust surface propagates forward from the base of a ramp that a major thrust sheet is moving over (Fig. 14), and eventually cuts upsection to meet the old thrust surface. The area enclosed by the new and old thrust surfaces becomes a horse, that, when transported over the newly formed ramp, produces an anticline in the overlying thrust sheet. Forward propagation of the lower thrust surface from the bases of newly formed ramps can occur several times, producing a succession of horses bounded by relatively flat floor and roof thrusts

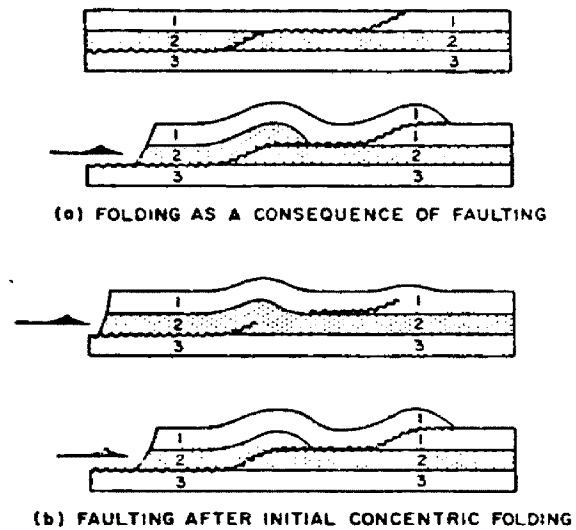


Figure 12. Identical fold and thrust geometry results from folding, then thrust faulting, or thrust faulting, then folding (from Dahlstrom, 1970).

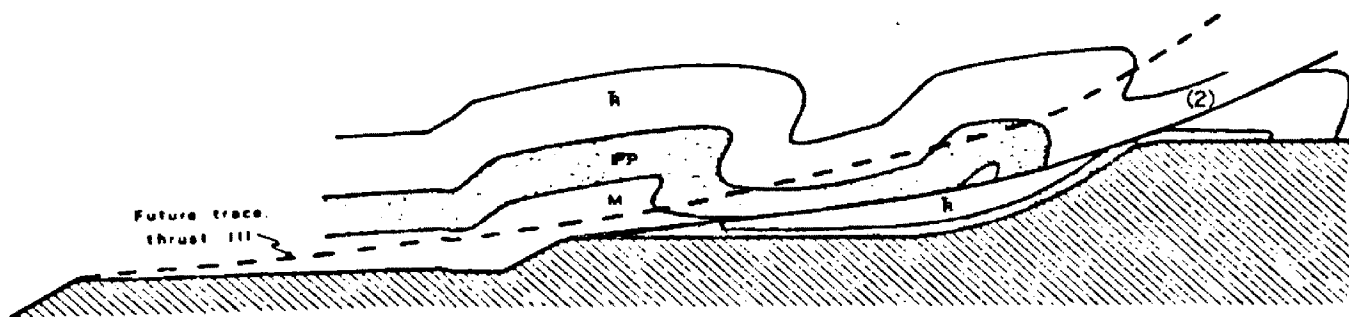


Figure 13. Second generation thrust (2) which cuts pre-existing folds (from Allmendinger, 1981).



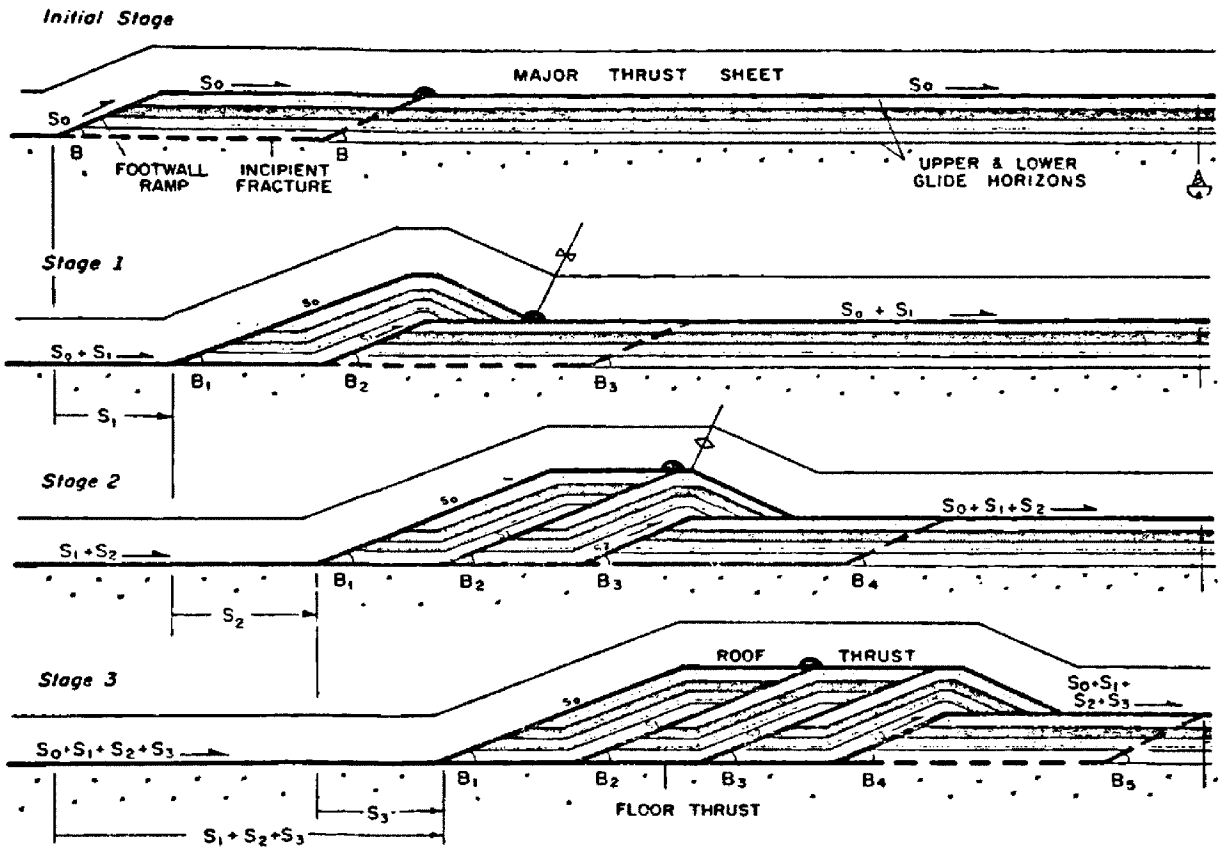


Figure 14. Development of a duplex by successive formation of horses (from Boyer and Elliot, 1982).

called a duplex structure (Boyer and Elliot, 1982). Boyer (1978) proposed two mechanisms to initiate a duplex. One requires that two or more imbricate faults or splays form simultaneously (Fig. 15A). If movement ceases on the hindward splay, but continues on the forward splay, the first of several horses that may build into a duplex structure form. The other mechanism requires that a thickened portion of a thrust sheet, such as a ramp monocline, impinge on a footwall ramp (Fig. 15B). As the thick hanging wall slab impinges on the ramp it may take less work to propagate a new thrust surface forward from the base of the ramp than to move the thickened portion of the thrust sheet over the ramp, thereby initiating duplex formation.

It is important to this study to extend Boyer's (1978) impingement model by examining the geometry resulting from large horizontal displacement of an allochthon composed of a horse and overlying thrust sheet. If the allochthon moves over the newly formed ramp onto the upper flat thrust surface, a three-part hinterland to foreland structural sequence of structural terrace, syncline, and elevated structural terrace results (Fig. 16). If erosion exposes the horse, the hinterland to foreland structural sequence is structural terrace, syncline, thrust fault, and exposed horse (Fig.

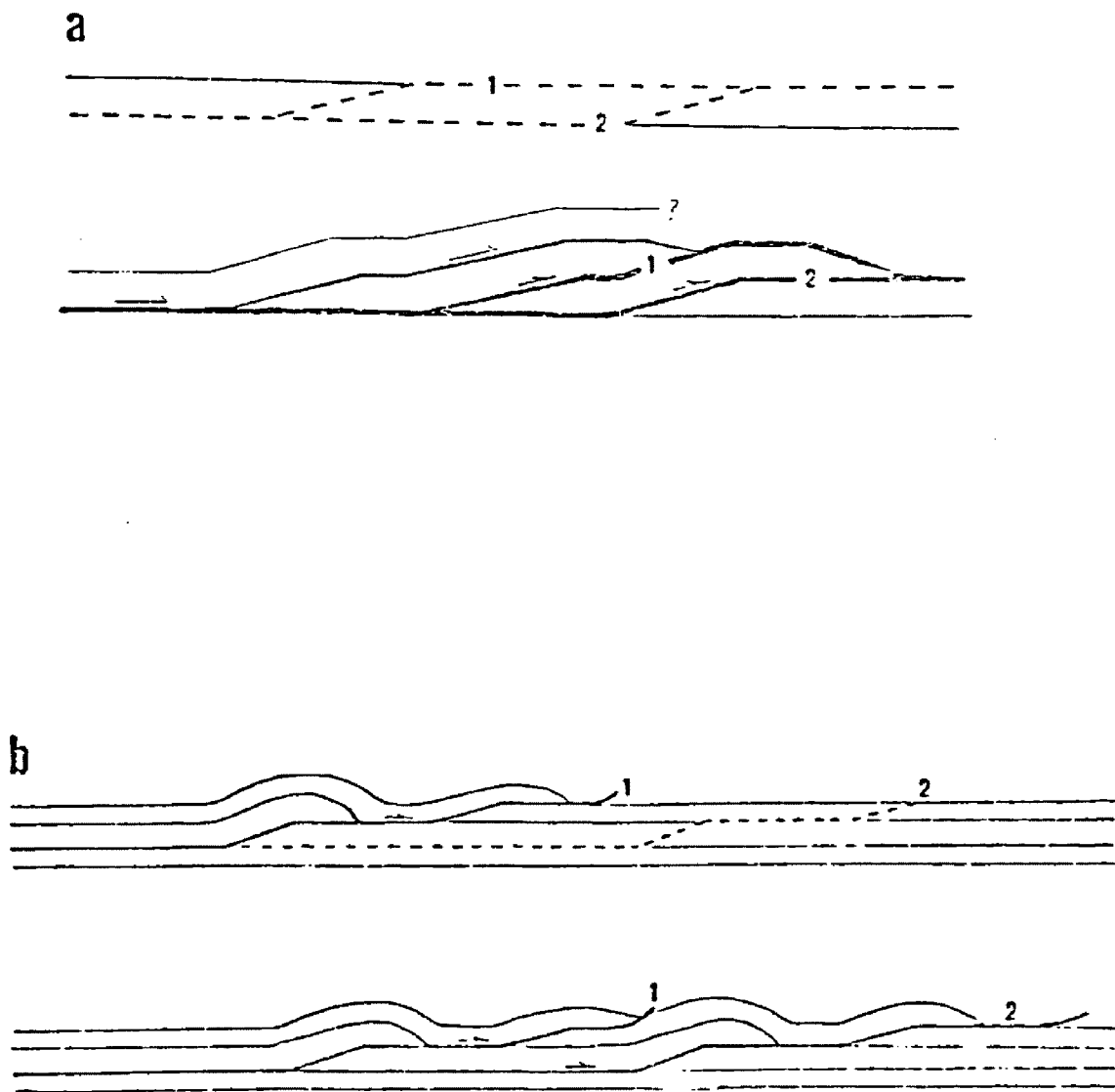
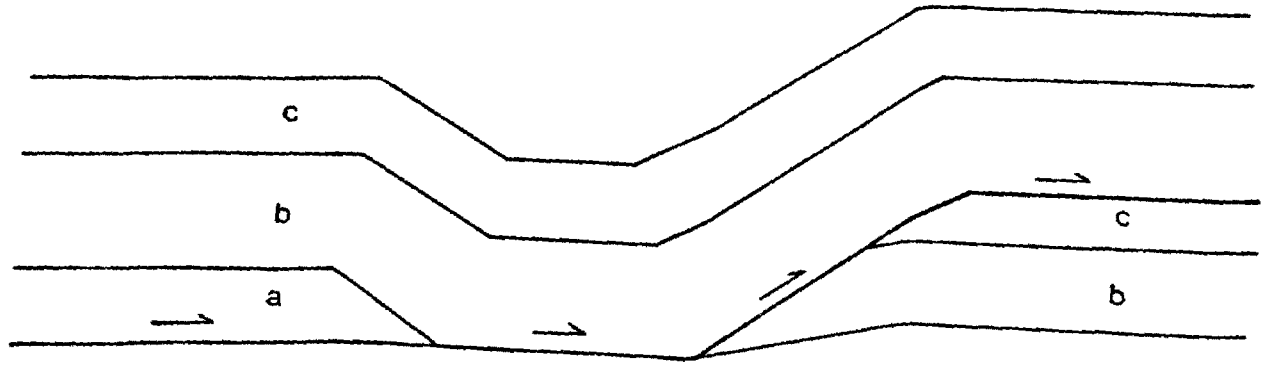


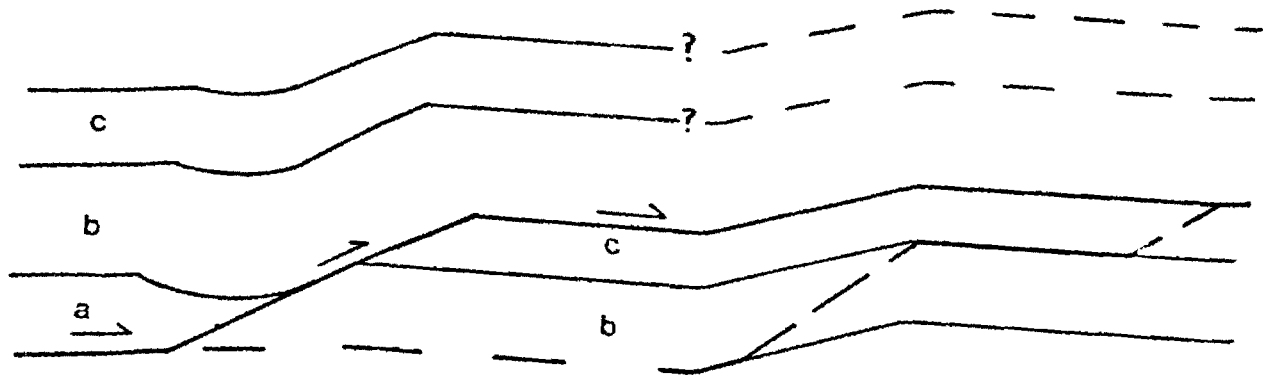
Figure 15. Two models for the initiation of a duplex:  
 a) initiation by simultaneous movement on two or more imbricate faults  
 b) initiation by a thickened section of the overriding sheet impinging on a footwall ramp (from Boyer, 1978).

- Figure 16. Geometric model for the impingement of a ramp monocline on a footwall ramp:
- A) overriding thrust sheet with ramp monocline moving toward ramp
  - B) impingement of ramp monocline on ramp and development of incipient thrust surface
  - C) resultant geometry after transport of overriding and lower thrust sheet onto a flat glide surface. Erosion level E-E' discussed in text, page 44.

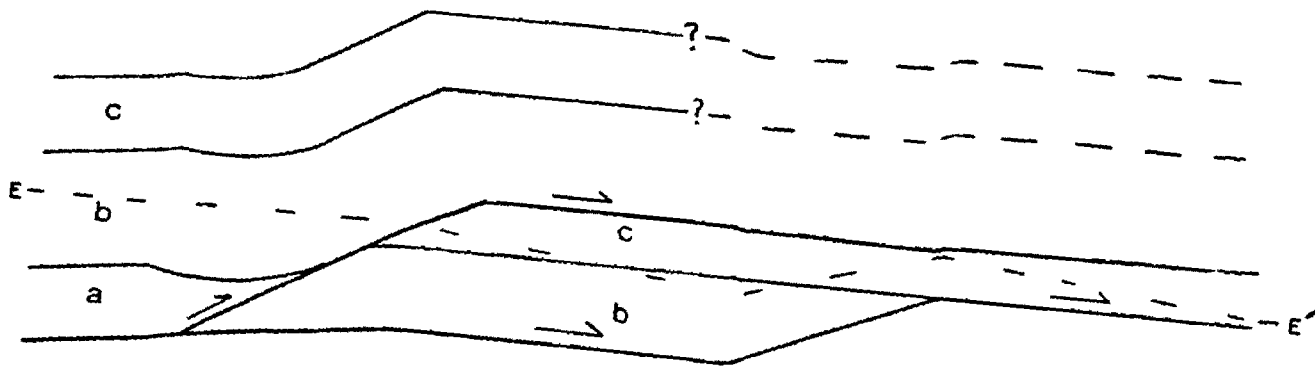
A)



B)



C)



16C). The same geometry after erosion is produced if the newly propagated thrust surface steps upsection in front of the overriding thrust sheet.

### Transverse and Oblique Structures

Transverse and oblique structures within the Canadian and Appalachian thrust and fold belt are commonly the result of tear faults within or in the footwall of thrust sheets (Dahlstrom, 1970; Wilson and Stearns, 1958; Boyer, 1978). Dahlstrom (1970, p. 375) defines a tear fault as "a species of strike slip fault which terminates both upwards and downwards against movement planes that may be detachments or thrust faults or low angle normal faults". Tear faults commonly reflect differential displacement either within flat thrust sheets or between rock bodies with two different styles of deformation. For example, tear faults commonly form where folds break laterally into thrusts. Tear faults that develop within thrust sheets can be responsible for cross folds (Dahlstrom, 1970). Oblique movement of a thrust sheet with a slip component up a tear fault produces an oblique or transverse anticline (Fig. 17). Conversely, oblique movement with a slip component down a tear fault produces an oblique or

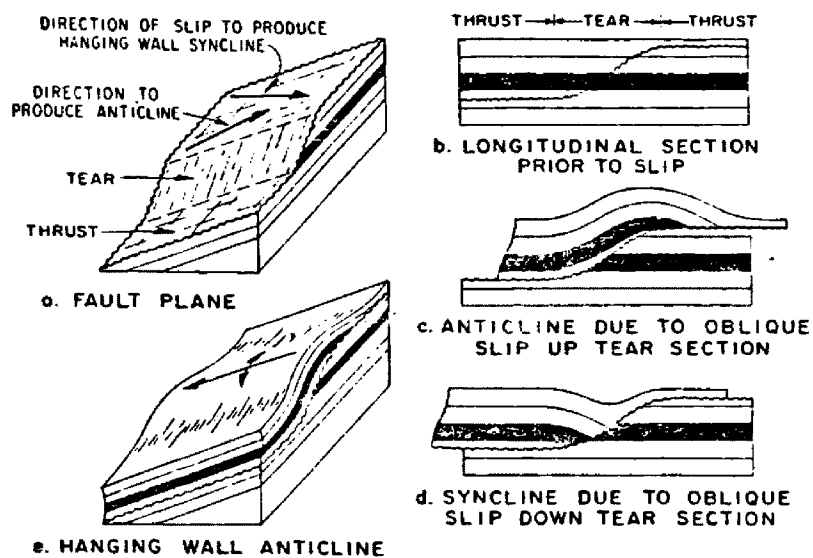


Figure 17. Oblique slip on a tear fault produces a syncline (normal slip component), or anticline (reverse slip component) (from Dahlstrom, 1970).

transverse syncline. With large horizontal displacement of the hanging wall, an oblique or transverse ramp monocline results (Wilson and Stearns, 1958; Price, 1965).

Dahlstrom (1970) and Boyer (1978) extended this model to a two sided structure (Fig. 18). Cutting a thrust sheet from a footwall and transporting it onto a level glide surface produces a transverse flat topped anticline, or if the limbs are far apart, opposing transverse monoclines. A thrust sheet of this type caught between thrusts will drape an overlying thrust sheet into an anticline (Fig. 19). Extending this concept to the case of a laterally sloping thrust surface is important to the analysis of the southeastern Scapegoat. If the thrust surface slopes toward the duplex structure, an asymmetric anticline-syncline pair of cross folds develops (Fig. 20). Erosion through the overlying thrust sheet exposes a reverse cross fault which is the boundary between the upper and lower thrust sheets.

### Extensional Faults

Extensional faulting in the Montana thrust and fold belt post-dates thrusting (Mudge, 1972). Consequently,



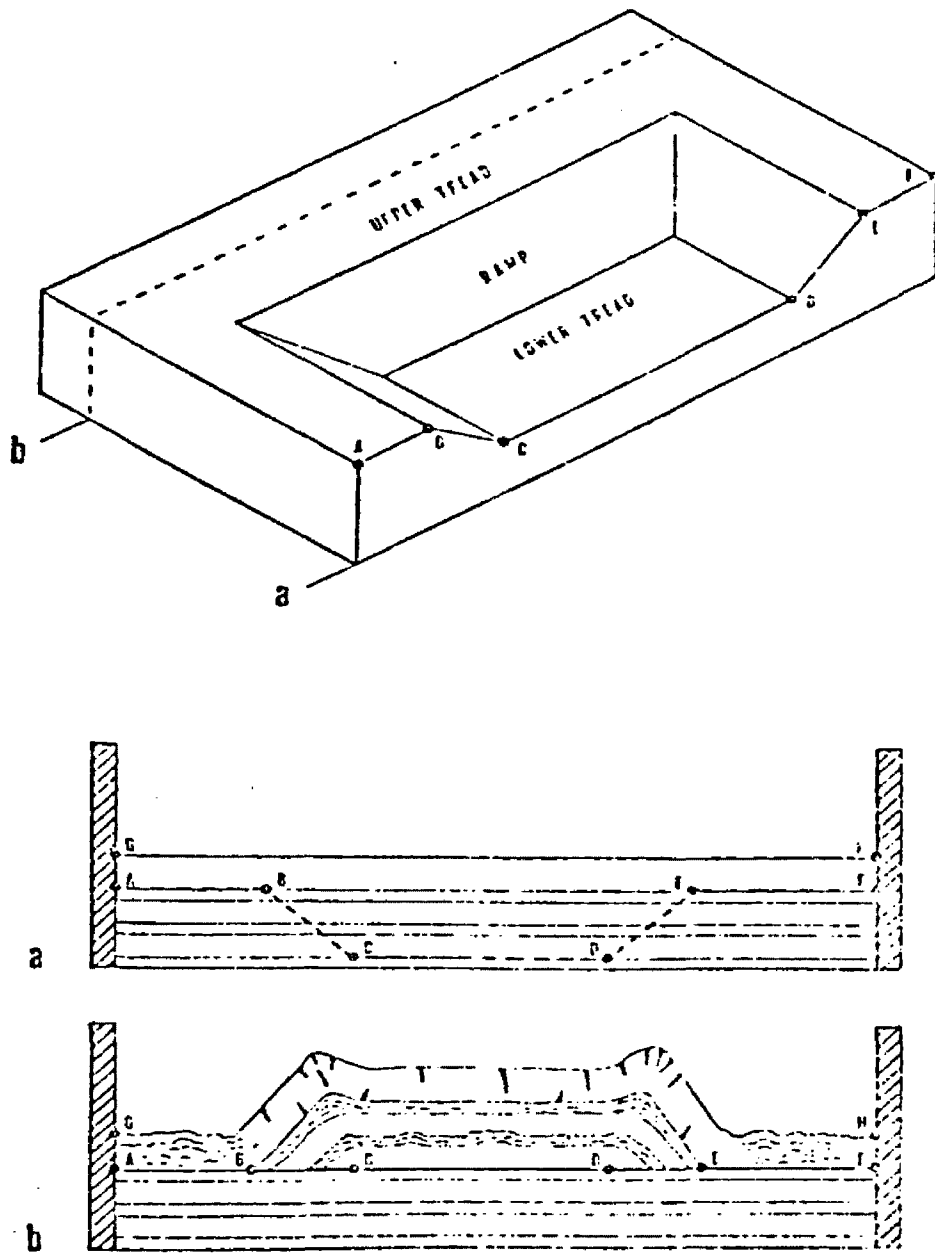


Figure 18. Development of opposing transverse ramp monoclines by cutting a thrust sheet from the footwall (from Boyer, 1978).

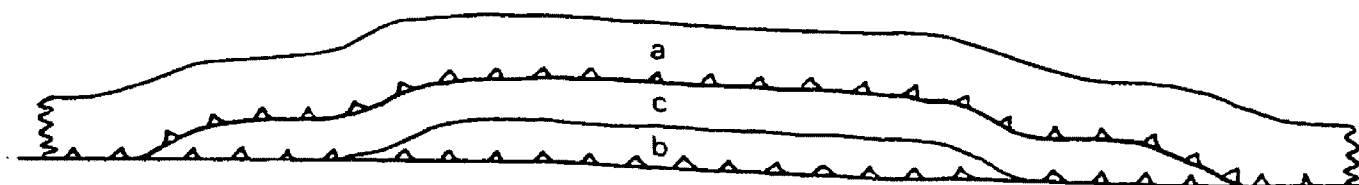


Figure 19. Lower thrust sheet with opposing transverse ramp monoclines overlain by a thrust sheet.

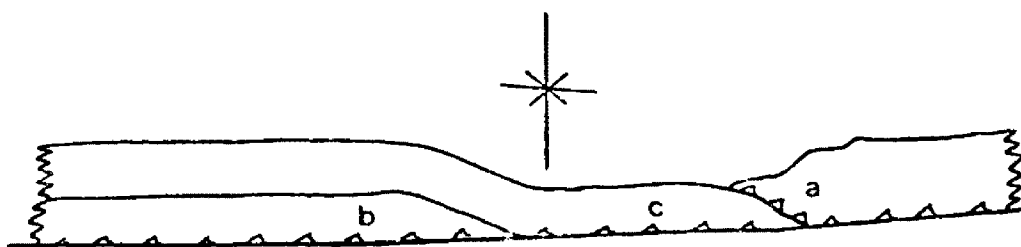


Figure 20. Lower and overlying thrust sheets emplaced on a dipping decollement and eroded, exposing a syncline and reverse cross fault. (Dahlstrom, 1970).

this discussion addresses only the development of extensional faults superposed on compressional structures. Perhaps the simplest type of normal fault within thrust belts to conceptualize is one localized over a footwall ramp (Fig. 21). The ramp provides a ready-made slip surface for down-dropping of the hanging wall against the footwall. Royse et al. (1975) documented faults of this type in the Wyoming-Idaho thrust belt and Constenius (1981) interpreted the North Fork normal fault west of Glacier National Park as a reactivated thrust ramp.

Dahlstrom (1970) diagrammed an extensional fault which remobilizes part of a pre-existing flat decollement surface as a slip surface and cuts through the overlying thrust sheet (Fig. 22). In this type of fault the strata characteristically rotate into the fault. Therefore, large stratigraphic offsets can be produced by only horizontal slip of the thrust sheet.

It is important for this study to examine the geometry resulting from listric normal faults cutting ramp monoclines. Ramp monoclines are probable places for normal faults to develop because the strata were folded, and possibly fractured during formation of the monocline. Ramp monoclines cut by hinterland-side-down extensional faults have downwarped rocks close to the

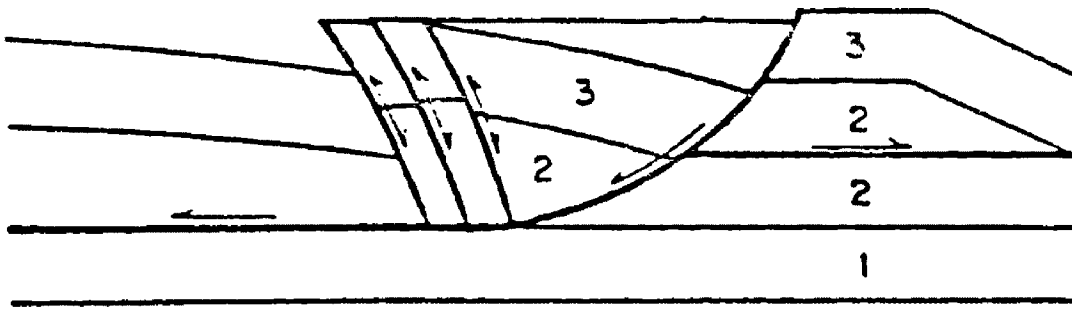


Figure 21. Localization of normal fault over footwall ramp (from Constenius, 1981).

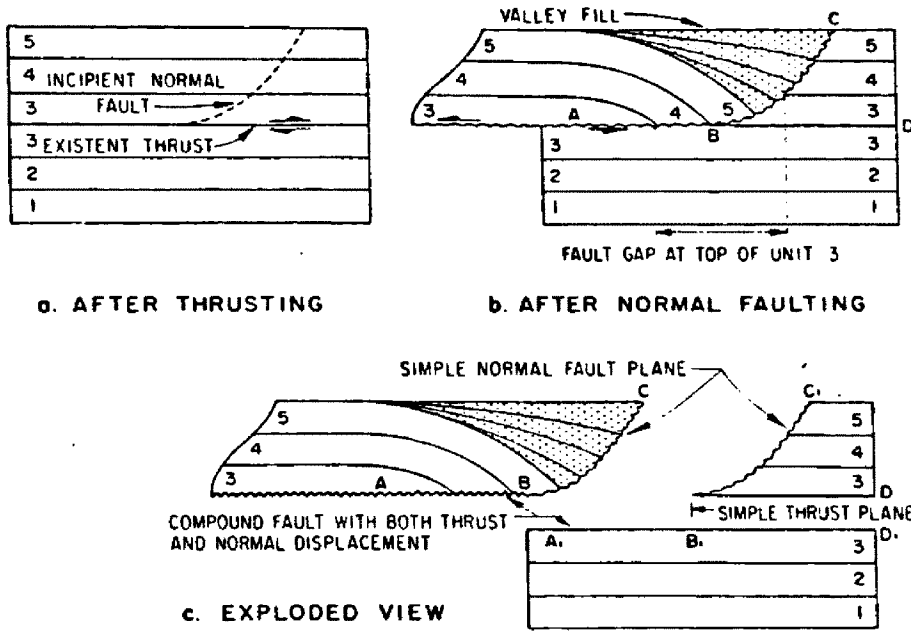


Figure 22. Extensional fault with large stratigraphic separation which cuts a thrust sheet (from Dahlstrom, 1970).

fault, and a structurally elevated area hinterland of the downwarp (Fig. 23). A similar geometry is produced if the faulted monocline resulted from abrupt hinterland stratigraphic thickening (Fig. 24). In most instances, the dips in a monocline produced by a steep upsection step of a thrust surface should be steeper than dips in a monocline due solely to stratigraphic thickening. Both these cases yield a structural geometry different from that of a reactivated footwall ramp, which has a structurally depressed area hinterland of the fault (Fig. 21).

#### Structures in the Footwall

The preceding discussion has dealt with structures that develop within thrust sheets and the hanging walls of listric normal faults by faults passing beneath and through them. These structures are superficial because they extend only to a decollement surface. However, some structures within thrust sheets result from movement below thrust surfaces. The hinterland to foreland development of the Canadian and Montana thrust and fold belts demands that overlying thrust sheets were folded as thrusts and folds developed beneath them (Dahlstrom, 1970) (Fig. 25). Furthermore, basement

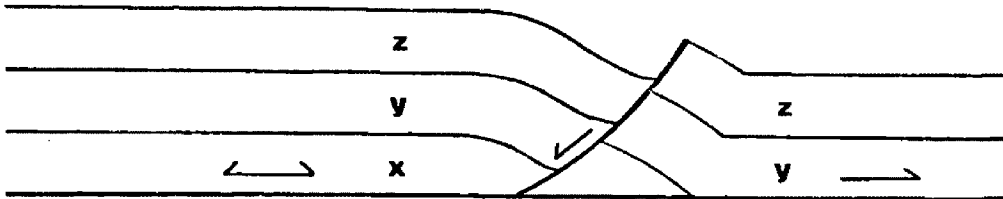


Figure 23. Normal fault cutting a ramp monocline. Note the elevated structural terrace hinterland of the fault.

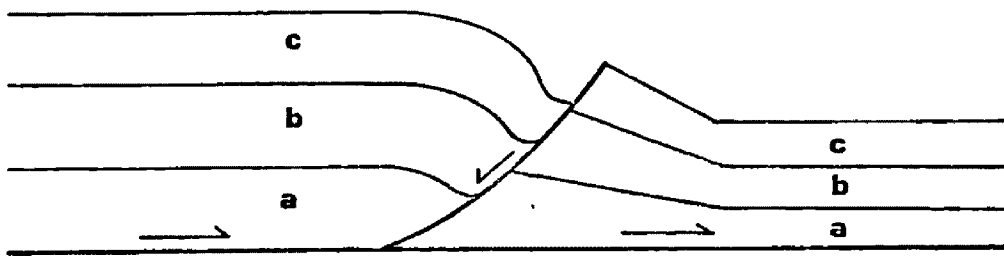


Figure 24. Normal fault cutting abruptly thickening strata in a thrust sheet.

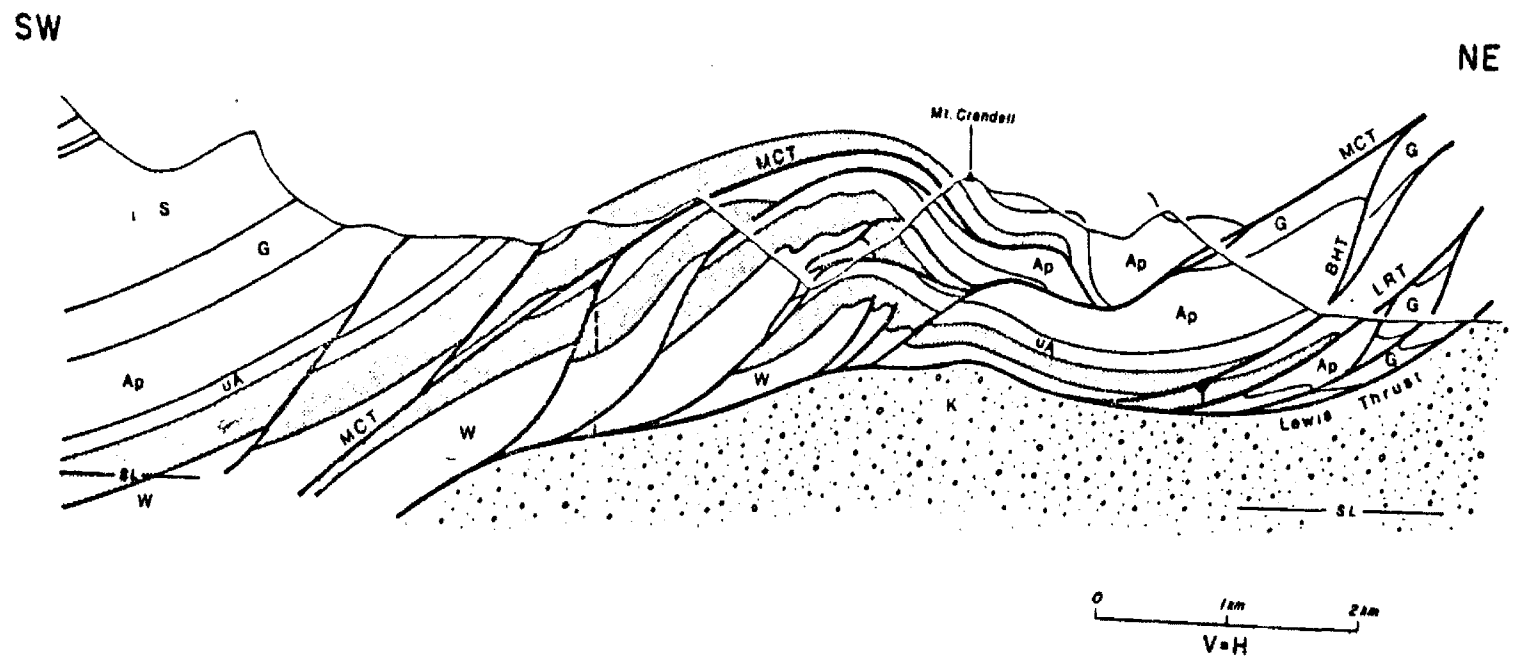


Figure 25. Structurally higher thrusts folded by lower thrusts (from Boyer and Elliot, 1982, after Douglas, 1952).



faulting which postdates thrusting will fold or fault overlying thrust sheets. Therefore, deformation below thrust sheets must be considered when analyzing surface structures.

CHAPTER 5  
ANALYSIS OF STRUCTURES  
Purpose and Method

In this chapter I analyze the structures of the southeastern Scapegoat using the models developed in the preceding chapter. My objective is to arrive at reasonable three-dimensional geometries for the structures. First, structures in the Hoadley thrust sheet are analyzed, then synthesized. The analysis of structures in the Silver King thrust sheet is carried out similarly. I then analyze the fault segments separating the Hoadley and Silver King thrust sheets using the models and resultant geometry of the intra-sheet structures as constraints.

Hoadley Thrust Sheet - Domain 2

Folds and Thrust Faults

The folds and thrust faults within domain 2 are analyzed north to south, from the Hoadley thrust and Continental Divide syncline, to the structural terrace and horse near the the Landers Fork segment (Fig. 2), then eastward to the Bighorn Creek syncline and

anticline north of the syncline.

Hoadley Thrust and Continental Divide Syncline. -

The Continental Divide syncline, when viewed down plunge (Fig. 26), is a classic hanging wall ramp fold. The moderately dipping northern limb probably conforms to the southwestern dip of the Hoadley thrust surface beneath it. The southern limb of the syncline is a ramp monocline, formed by an upsection step of the Hoadley thrust surface from probably the Empire-Spokane to the Mount Shields (Fig. 27). The Mount Shields soles the thrust sheet from the ramp monocline to the surface trace of the Hoadley thrust fault. That the Empire-Spokane is at the base of the ramp is not apparent, however, it can be inferred. The Hoadley must cut down into the Empire-Spokane because it is exposed north of the Bighorn Creek syncline in domain 2 (Fig. 5). North of the Scapegoat Wilderness, Mudge (1972) found that thrust sheet glide surfaces were commonly localized within the Spokane. Based on these observations, I infer that the Empire-Spokane is a probably at the base of the hanging wall ramp. The ramp continues from the southeastern termination of the Continental Divide syncline eastward to the Hoadley fault, where the Hoadley thrust surface has cut upsection to within the Helena Dolomite and the ramp

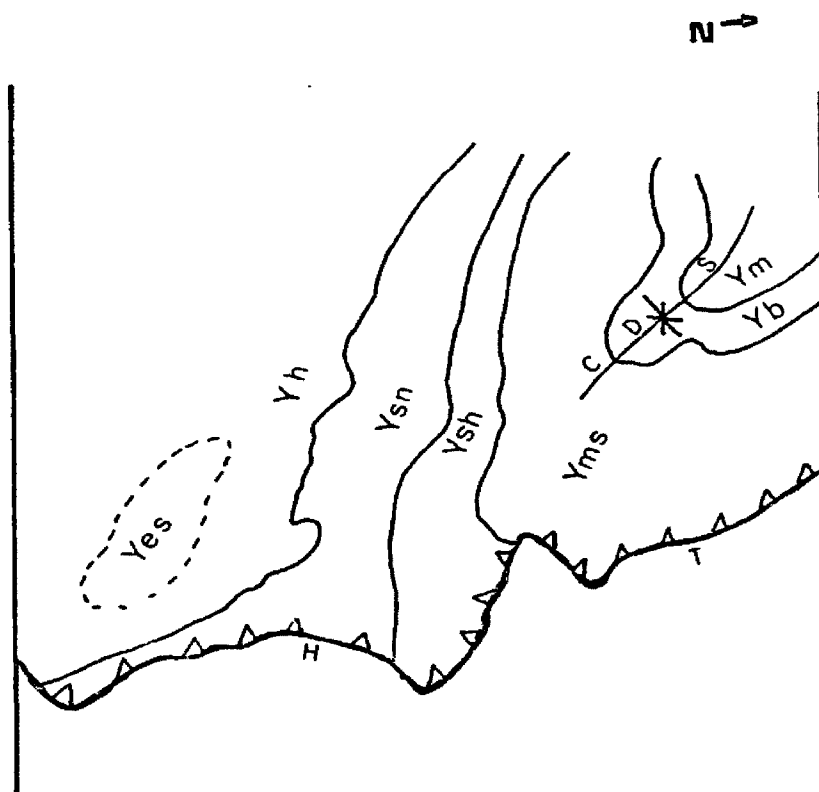
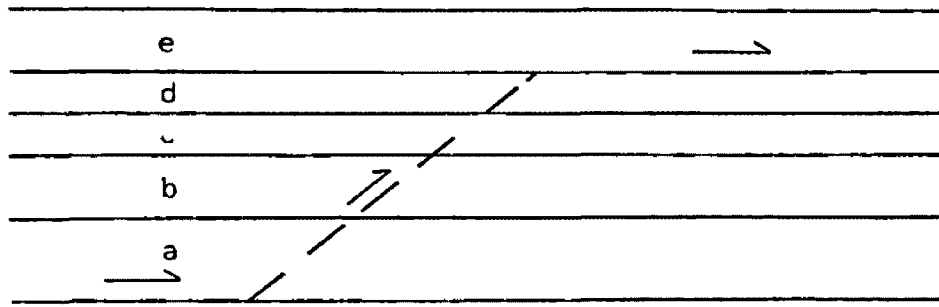


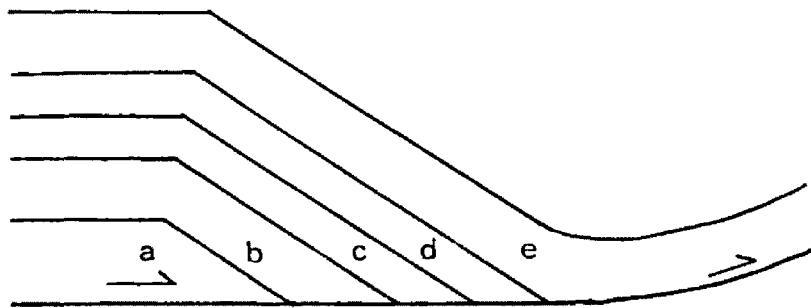
Figure 26. Map view of the Continental Divide syncline. View west-northwest, sub-parallel to plunge direction of syncline.

- Figure 27. A) Strata with incipient thrust ramp  
B) Thrust sheet after transport onto gently dipping to flat glide surface  
C) Northern portion of figure 5, sec. 1 without extensional faults. Note similarity to B.

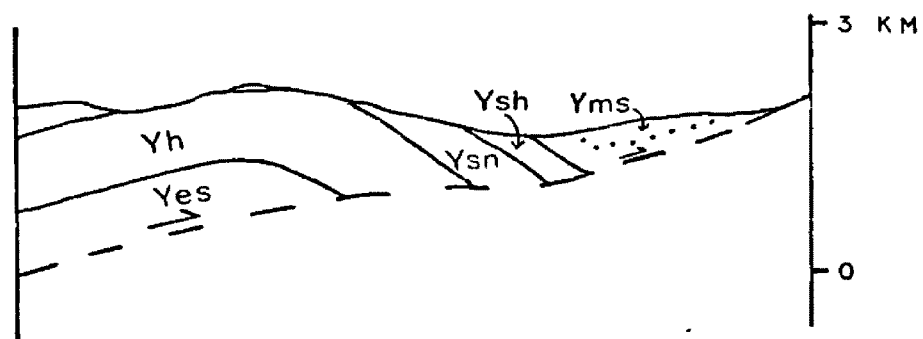
A)



B)



C)



reduced (Fig. 5, sec. 2).

The location of the footwall ramp which corresponds to the hanging wall ramp monocline is unknown. An upsection step from Empire- Spokane to Mount Shields represents approximately 3 km of structural relief. The location of such a ramp would be reflected by a south to southwest dipping panel of rocks draped over the ramp, or a normal fault with as much structural relief. Neither of these features is present within the thesis area, implying that the footwall ramp has been destroyed by later deformation or the ramp monocline has been transported at least 10 km across the map area on a near-planar footwall.

Structural Terrace and Horse. - The structural terrace south of the Continental Divide syncline (Fig. 5) is marked by shallow dips and a large outcrop of Mount Shields. Assuming the structural terrace is allochthonous, at least two geometries may produce it, that of a thrust sheet of nearly constant thickness resting upon a flat or gently dipping thrust surface (Fig. 9), or thickness changes in the thrust sheet fortuitously located over footwall slopes which nullify thickening of the thrust sheet. The latter seems highly unlikely and the former more probable. The inferred constant thickness of the Hoadley thrust sheet in this

area implies the sole of the thrust sheet beneath the structural terrace is localized within the Empire-Spokane (Fig. 28).

The horse between the Silver King thrust and its rejoining splay which bounds the southern end of the structural terrace was probably plucked out of the footwall of the Landers Fork segment, because it is stratigraphically displaced only a small distance. Reverse drag along the rejoining splay and normal drag from reactivation of the Landers Fork segment warped the horse into an anticline (Figs. 29 and 5, sec. 1).

Bighorn Creek Syncline. - Because of the anomalous oblique trend of the Bighorn Creek syncline (Fig. 2), deciphering its subsurface geometry and structural development is a complex problem. Several disparate interpretations are possible and one consequently dictates the geometry of the Bighorn Creek fault segment. Possible interpretations are 1) an asymmetric cross fold syncline with the steeply dipping limb being a ramp monocline (Fig. 19), 2) oblique westward slip down a tear fault (Fig. 20), 3) that the syncline is the surface reflection of structure in the footwall, and 4) that the syncline was formed by a northwest-southeast compressional event or east-west trending shear couple. The interpretation that best meets the constraints of



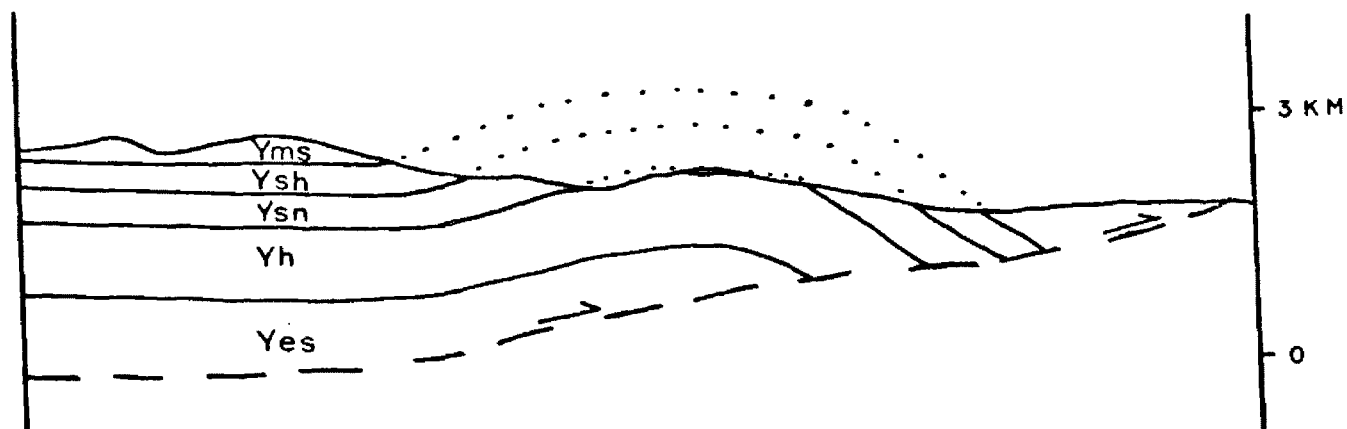


Figure 28. Figure 27C extended southwestward showing probable geometry of structural terrace.

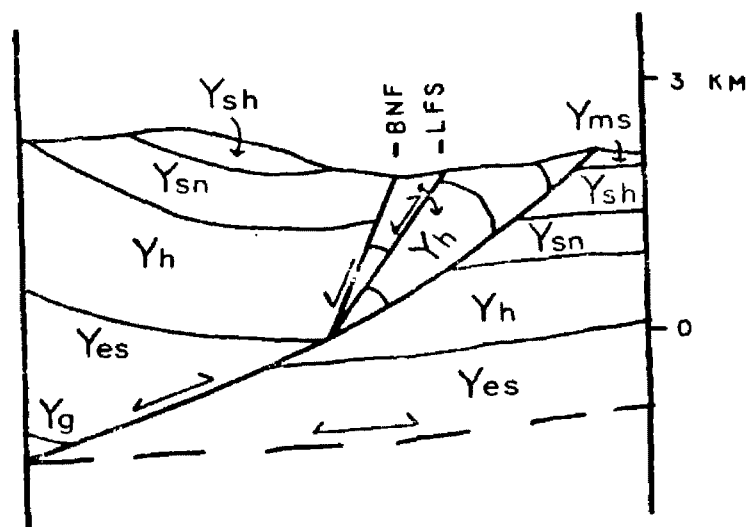


Figure 29. Southern portion of figure 5, cross-section 1, showing anticlinal form of the horse in the footwall of the Landers Fork segment (LFS).

the surface geology is the first. Although no direct evidence, such as a down plunge projection, supports the interpretation, two indirect lines of evidence do.

First, if the Hoadley thrust surface has a westward dip component, a geologically reasonable cross section can be drawn through the Bighorn Creek syncline using this interpretation (Fig. 5, sec. 4). Second, the eastern segments of the Cooney Creek and Red Ridge faults follow the northwest limb of the syncline until the faults are truncated by Bighorn Creek segment. They could be following structural weakness resulting from bending of strata over the hanging wall ramp responsible for the transverse ramp monocline.

The interpretation of oblique westward slip down a tear fault, in this case the Bighorn Creek segment, is rejected because it requires structural relationships which do not occur elsewhere in the region. To form the oblique trend of the syncline, extension across the fault must increase southward (Fig. 30), which is unlikely because it either drops abruptly to zero at the Landers Fork segment, because there is no sign of east-west extension in the Silver King sheet, or it occurred before thrust displacement on the Landers Fork segment. However, extensional faults overridden by thrust sheets are not found elsewhere in the Scapegoat

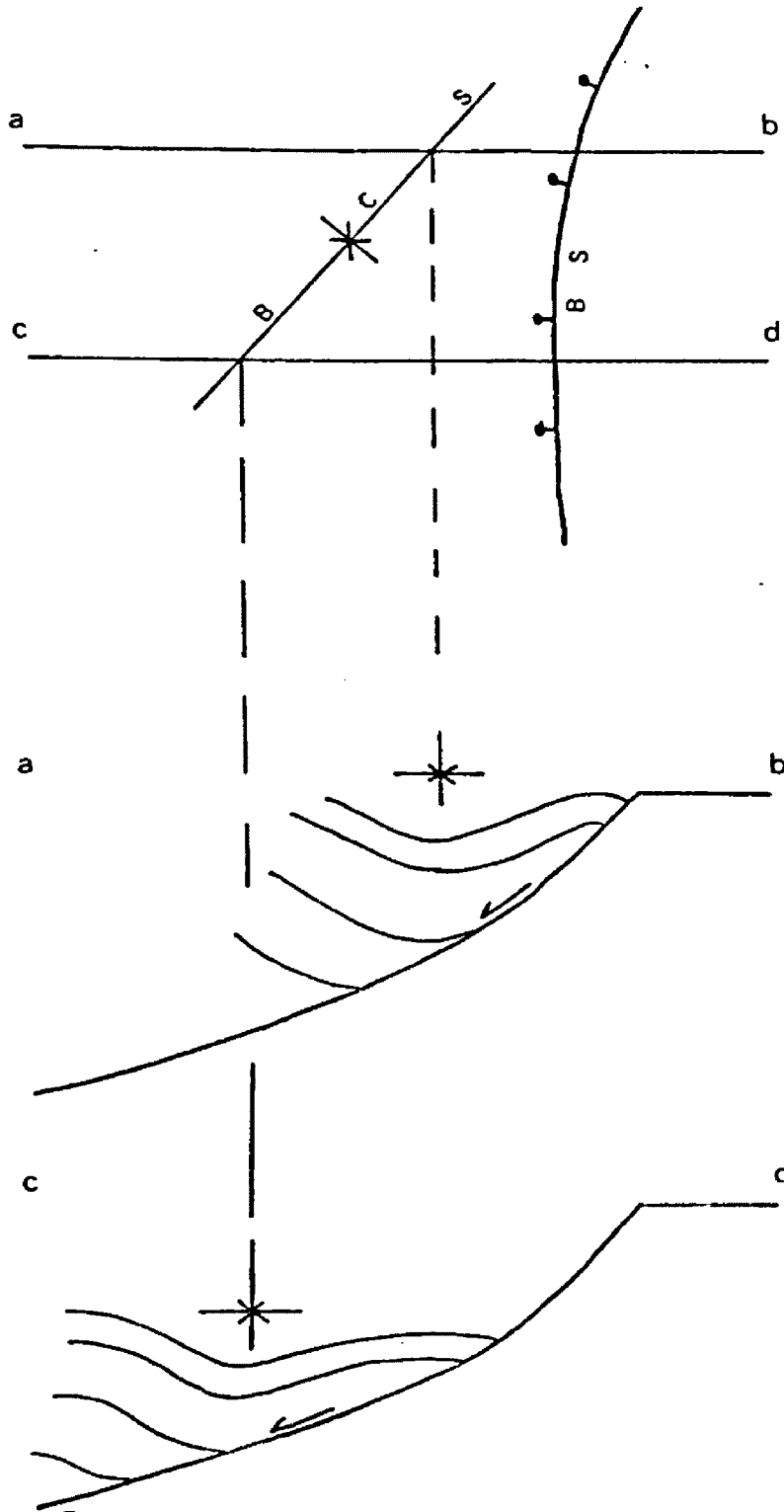


Figure 30. Map pattern of Bighorn Creek syncline (BCS) and Bighorn Creek segment (BS) with model cross sections showing greater extension across the southern portion of the west-dipping normal fault.

area (Mudge et al., 1974; Earhart et al., 1977; Mudge et al., 1983).

The syncline is an improbable surface reflection of footwall structure. The syncline abruptly ends against the Bighorn Creek and Landers Fork segments (Fig. 2). A footwall depression causing the syncline would have to underly only domain 2, and fortuitously end directly below the Silver King thrust fault segments.

Two remaining possible interpretations, that of a northwest-southeast compressional event, or an east-west trending shear couple, are rejected immediately. No other folds or faults within the southeastern Scapegoat parallel or sub-parallel the Bighorn Creek syncline, which would be expected if the syncline were formed by a regional compressive event or shear couple.

The lateral ramp monocline interpretation of the Bighorn Creek syncline demands that the anticline whose axis is delineated by the Red Ridge fault north of the Bighorn Creek syncline is a rootless fold (Figs. 13 and 5, sec. 2). If the Hoadley thrust sheet beneath the syncline is soled by Missoula group strata (Fig. 31), the Hoadley thrust surface must cut downsection to the north, in the direction of tectonic transport, because the Helena soles the thrust sheet along the surface trace of the Hoadley thrust. (Fig. 5). This geometry

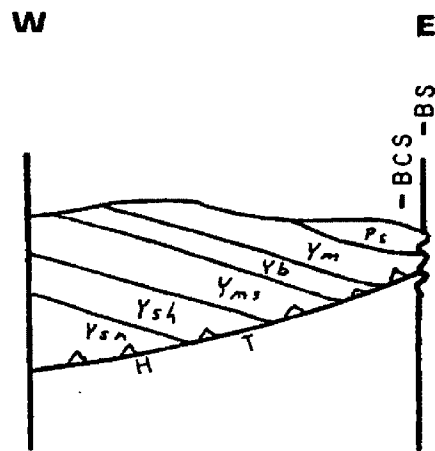


Figure 31. Preferred model of the Bighorn Creek syncline. Model cross section along figure 5, sec. 4 without extensional faults. Geometry of the Bighorn Creek segment (BS) not established.

is common where thrust faults cut pre-existing folds (Dahlstrom, 1970; Allmendinger, 1981). Although impossible to confirm this geometry in the study area, an analogue is exposed 14 km to the northeast where the Eldorado thrust cut through a pre-Middle Cambrian anticline (Mudge et al., 1983). The timing of the domain 2 anticline is enigmatic. Unlike the anticline cut by the Eldorado thrust, there are no overlying Paleozoic rocks which constrain its age. The only constraint is that it had to form before being cut by the Hoadley thrust, and was probably eroded to expose the Helena Dolomite before being overridden by the Silver King sheet along the Bighorn Creek segment (Fig. 5, sec. 5).

#### Extensional Faults

The Red Ridge and Cooney Creek faults are the only extensional structures in domain 2 (Fig. 2), and their origin is enigmatic. They could have formed as reverse faults, then undergone extensional reactivation, or be only extensional. Deformation within the Cooney Creek and Red Ridge fault zones was brittle and there is no evidence of compressional drag folds. Furthermore, the areal geometry of the faults does not resolve their origin. The Cooney Creek and Red Ridge faults are

truncated by the Bighorn Creek segment, but this cross cutting relationship does not establish the relative ages of the faults. Extension could post-date the Bighorn Creek segment, but not continue across it. The high angle of the faults at the surface in the central portion of domain is typical of both extensional and compressional listric faults.

The extension which produced normal offset on the Cooney Creek and Red Ridge faults, although not verified in the field, is interpreted to be post-thrusting, as it is in the Canadian (Dahlstrom, 1970) and other parts of the Montana (Mudge, 1972) thrust and fold belts.

#### Synthesis of Domain 2 Structure

The major structures within domain 2, the Continental Divide syncline, structural terrace, and Bighorn Creek syncline probably directly result from the path the Hoadley thrust cut through Belt strata. The southern limb of the Continental Divide syncline is a ramp monocline, formed when the Hoadley thrust cut upsection from the Empire-Spokane to the Mount Shields. The Mount Shields continues to sole the Hoadley thrust sheet northeastward to the surface trace of the Hoadley thrust (Fig. 27). The structural terrace is the

surface expression of a portion of the Hoadley thrust sheet of constant structural thickness everywhere soled by the same stratigraphic horizon, probably in the Empire-Spokane. The horse along the southern edge of the structural terrace was plucked out of the footwall and displaced only a small distance as the Silver King thrust sheet overrode domain 2 on the Landers Fork segment. The Bighorn creek syncline is interpreted as a transverse ramp monocline lying on a gentle west-dipping thrust surface (Fig. 31). The anticline north of the Bighorn Creek syncline could have been a pre-existing structure cut by the Hoadley thrust.

Although not constrained in the southeastern Scapegoat by field data, extensional faulting is interpreted to post-date thrusting. This interpretation does not constrain the origin of the Cooney Creek and Red Ridge normal faults, which could be reactivated reverse faults, or only extensional.

### Silver King Thrust Sheet - Domain 3

As with the Hoadley thrust sheet, structures in the Silver King sheet are analyzed north to south, first thrust faults and folds, then extensional faults. The Blackfoot normal fault and Heart Lake syncline, although



in the Silver King sheet, are discussed with the boundary segments of the Silver King thrust because of the close areal association of the fault and syncline with the Landers Fork segment.

### Thrust Faults and Folds

Falls Creek Segment. - The Falls Creek segment bounds the leading edge of the Silver King thrust sheet in the southern part of the map area (Fig. 2) and juxtaposes gently disturbed Empire-Spokane and Helena strata (Fig. 5) onto highly contorted Paleozoic strata along a shallowly dipping thrust surface (24 ). The portion of the Silver King thrust sheet extending from the Falls Creek segment to the Lookout Creek normal faults is deformed only by the Caribou Peak bedding plane thrust and anticline (Fig. 5). Therefore the Silver King thrust surface beneath this portion is probably not offset by significant faults or footwall ramps, nor does this portion of the thrust sheet contain significant intra-sheet structures resulting from hanging wall ramps.

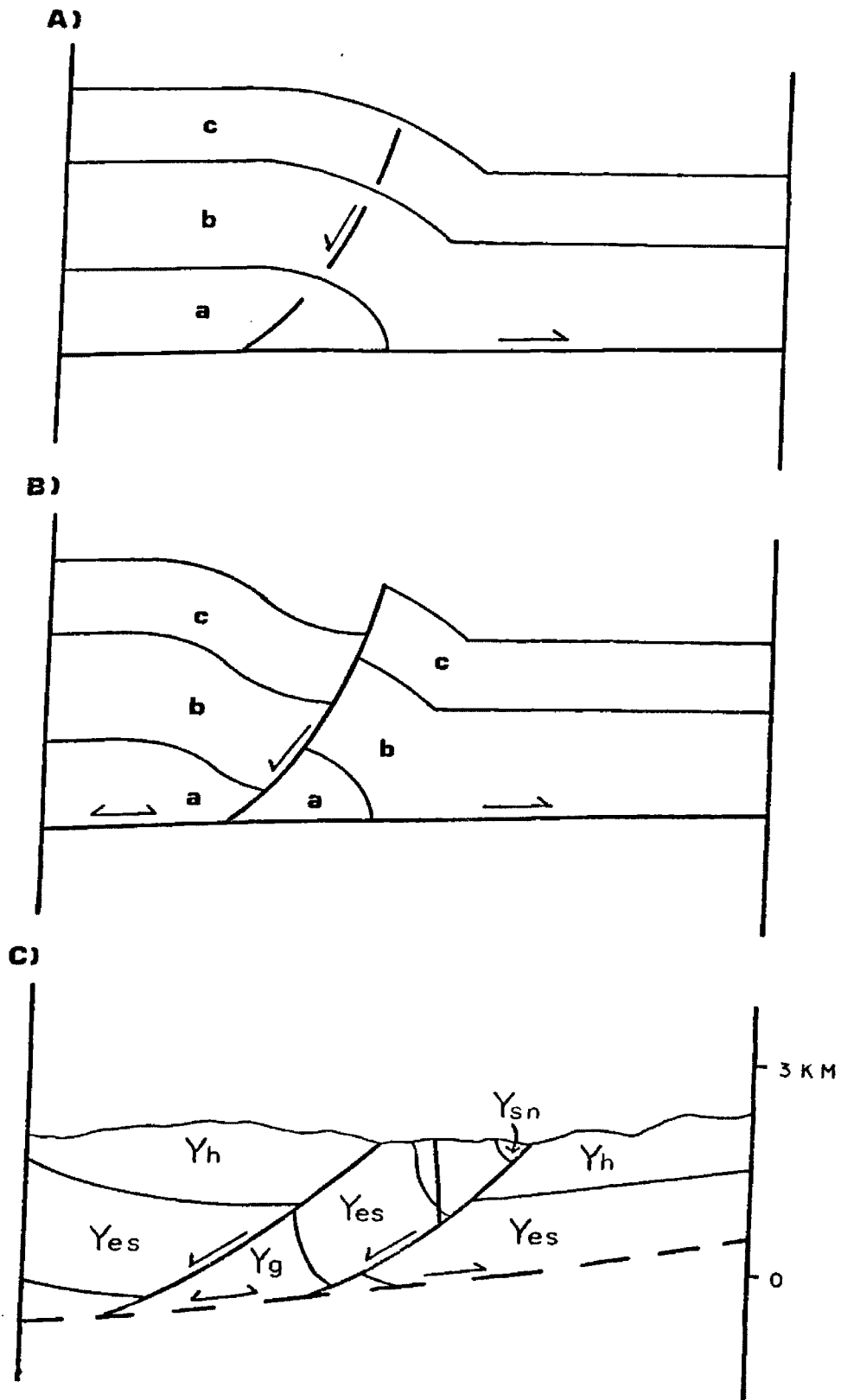
Caribou Peak Thrust and Anticline. - The Caribou Peak thrust and overlying anticline (Fig. 2) are minor components of the structural geology of the southeastern Scapegoat. They are confined to the Caribou Peak area,

and because they are within the Helena and intersect no other structures, provide no clues to the structural evolution of the southeastern Scapegoat Wilderness. They are shortening structures that parallel the Falls Creek segment, therefore, they probably formed during transport of the Silver King thrust sheet. Their timing during transport is unknown.

### Extensional Faults

Lone Mountain and Lookout Creek faults. - The Lone Mountain normal fault (Fig. 2) was interpreted as a north-yielding thrust by Mudge et al. (1974), and as a south-side down normal fault by Earhart et al. (1977) and Mudge et al. (1983). The juxtaposition of Helena on the south against Empire-Spokane on the north establishes the fault as a south-side down normal fault, but previous workers have not addressed its geometry. The Empire-Spokane dips north, away from, not into the fault as expected in a normal fault footwall (Fig. 5). The north-dipping strata are best explained by interpreting the Lone Mountain fault as cutting a ramp monocline (Figs. 23 and 32). The sequence of structures from south to north across the fault matches the hinterland to foreland sequence of the normal faulted ramp monocline model, that of elevated

Figure 32. Model development of the Lone Mountain and  
Lookout Creek normal faults  
A & B) ramp monocline cut by normal fault  
C) southern segment of figure 5, sec. 3  
showing ramp monocline cut by three normal  
faults.



structural terrace, downwarp, fault, foreland-dipping monocline, and lower structural terrace. The monocline probably results from both abrupt southward stratigraphic thickening and the subsurface truncation of the Greyson Formation (Fig. 32C), which outcrops south (Mudge et al., 1983), but not north of the Lone Mountain fault.

Although possible, the Lone Mountain fault is probably not a reactivated thrust. The fault's footwall strata are not so contorted and shattered as the footwall strata of the Landers Fork segment, which was reactivated.

The Lookout Creek normal faults are readily accommodated in the ramp monocline. The northern Lookout Creek fault, which is southside-down, is interpreted to have formed at the leading, more tightly folded, portion of the monocline (Fig. 32C). The southern fault is probably antithetic to the northern fault, joining it at depth.

The presence of the Lone Mountain ramp monocline constrains the geometry of the Silver King thrust sheet. The thrust sheet can be interpreted as nearly continuous from the Falls Creek segment to the southwest edge of the study area, broken only by the Lone Mountain, Lookout Creek, and Blackfoot normal faults. This

demands that segments of the Silver King thrust bounding the Hoadley thrust sheet, the Landers Fork and Bighorn Creek segments, form a continuous fault. Also, this interpretation requires no footwall ramps or faults below the Lone Mountain and Lookout Creek normal faults. Their offset can be accommodated by dominantly horizontal extension (Figs. 32C and 5, sec. 3).

#### Silver King Thrust - Bounding Segments

The geometry and evolution of the Landers Fork and Bighorn Creek segments are fundamental to understanding the structural evolution of the southeastern Scapegoat. Their configuration determines the relative structural level, displacement, and timing of movement of the Hoadley and Silver King thrust sheets.

#### Southern Boundary

Landers Fork Segment. - The Landers Fork segment extends west from its intersection with the Bighorn Creek segment and Lone Mountain normal faults in the south-central portion of the map area (Fig. 2). It dips 82 S, more steeply at the surface than most thrust faults. The high dip results from displacement of the footwall horse onto a more steeply dipping portion of

its footwall, thereby steepening the overlying Landers Fork segment (Fig. 34).

Blackfoot Normal Fault. - The Blackfoot normal fault parallels the Landers Fork segment on the south. I interpret that it formed during extensional reactivation of the Landers Fork segment, and that it cuts through the Silver King thrust sheet from the Landers Fork segment fault surface (Fig. 34). Normal drag in the footwall of the Landers Fork segment indicates it was reactivated (Fig. 5, sec. 1). Furthermore, the close proximity and paralleling of the two faults, and their joining into a single normal fault near the western boundary of the study area (Mudge et al., 1974) indicates they are genetically related. As with the Lone Mountain and Lookout Creek normal faults, it is possible to accommodate offset on the Blackfoot normal fault by mostly horizontal extension (Fig. 5, sec. 1).

Heart Lake Syncline. - The geometry of the Heart Lake syncline (Fig. 2) establishes westward continuation of the Lone Mountain ramp monocline. Although cut by the Blackfoot normal fault, the overall geology across the Heart Lake syncline-Landers Fork segment area matches the model of a ramp monocline impinging on a footwall ramp (Figs. 16, 34, and 35);

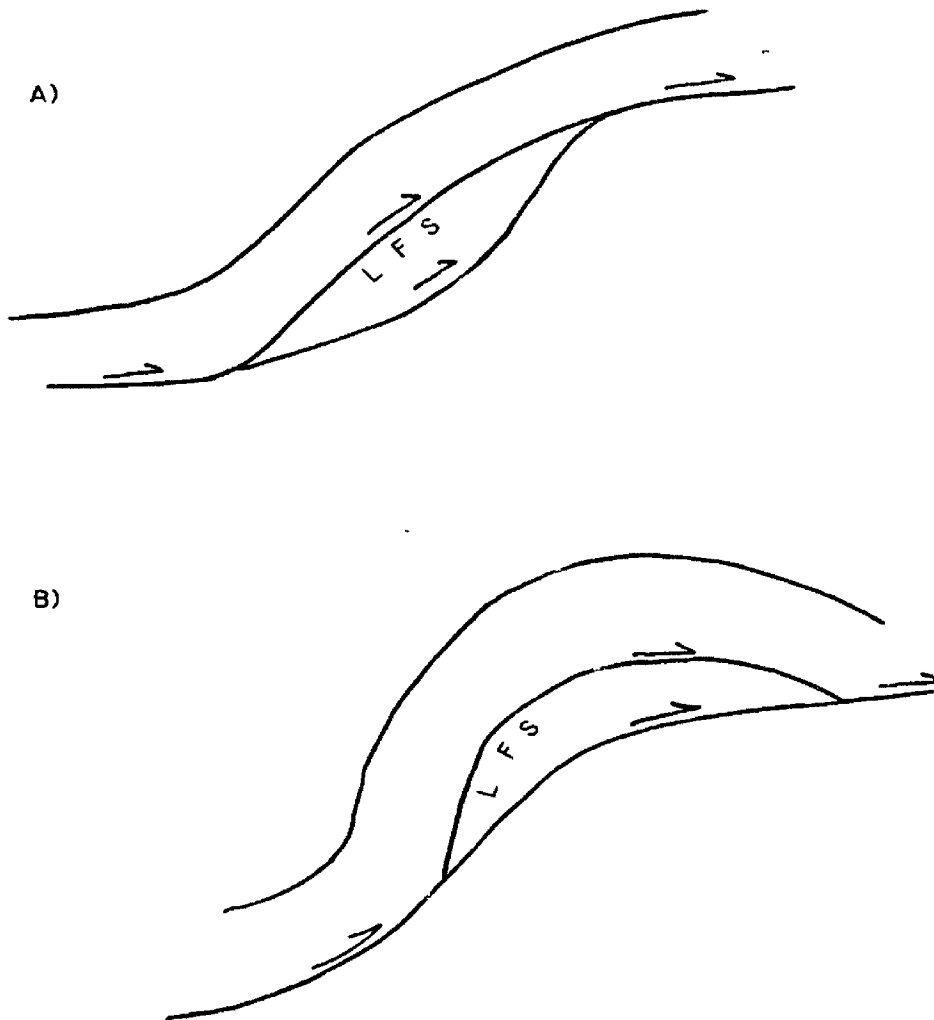
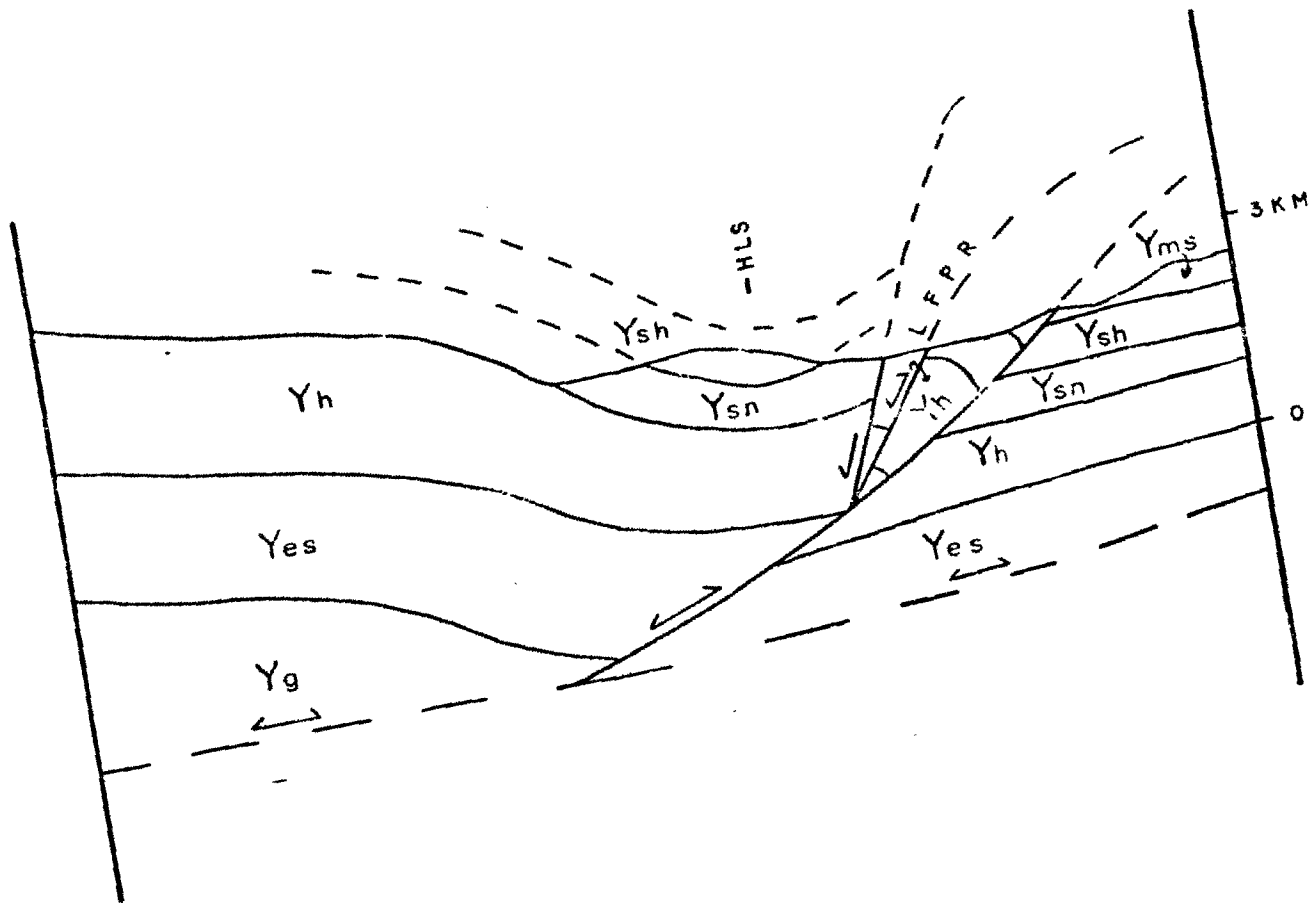
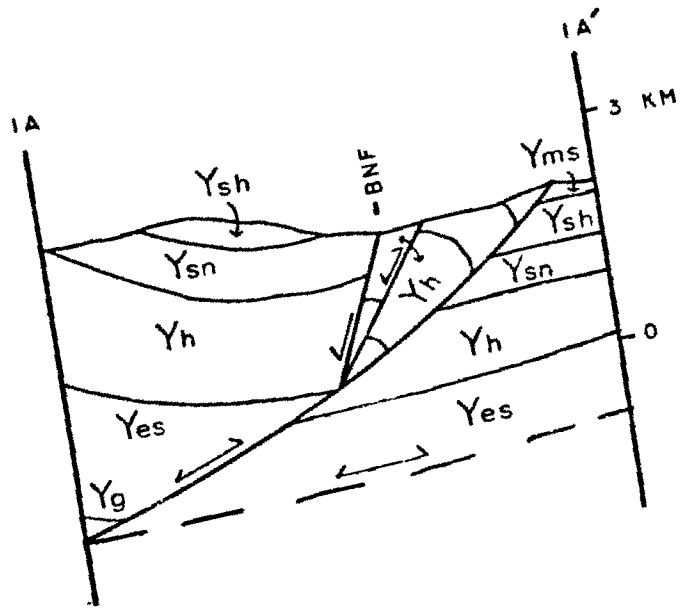


Figure 33. Model cross sections illustrating that displacement of the footwall horse steepened the Landers Fork segment (LFS).



Figure 34. Southern portion of figure 5, sec. 1 showing the Blackfoot normal fault (BNF) joining the Landers Fork segment at depth.

Figure 35. Model cross section based on figure 5, sec. 1 showing that present surface geology fits the model of a ramp monocline impinging on the Landers Fork segment paleoramp (LFPR). Compare with figure 16.



that of hinterland structural terrace, syncline with hindward limb a ramp monocline, thrust fault on a paleo-footwall ramp, and foreland structural terrace. Eastward truncation of the syncline probably results from displacement of the ramp monocline up the Landers Fork segment paleoramp. Westward transformation of the syncline to a north-dipping monocline probably results from westward increasing extension across the Landers Fork segment and Blackfoot faults, which rotated hanging wall strata into the faults.

#### Bighorn Creek Segment

Establishing the geometry and evolution of the Bighorn Creek segment of the Silver King thrust is the key in deciphering the structural development of the southeastern Scapegoat Wilderness. Previous workers have interpreted the segment to be west-side down, normal, and within the Hoadley thrust sheet, in which they included the Silver King thrust sheet (Mudge et al., 1974; Mudge and Earhart, 1980; Mudge et al., 1983). New interpretations of the Bighorn Creek segment must meet two major constraints. One constraint stems from the structural continuity of domain 3 through the Lone Mountain fault and ramp monocline, which establishes the Bighorn Creek segment as a continuation of the Landers

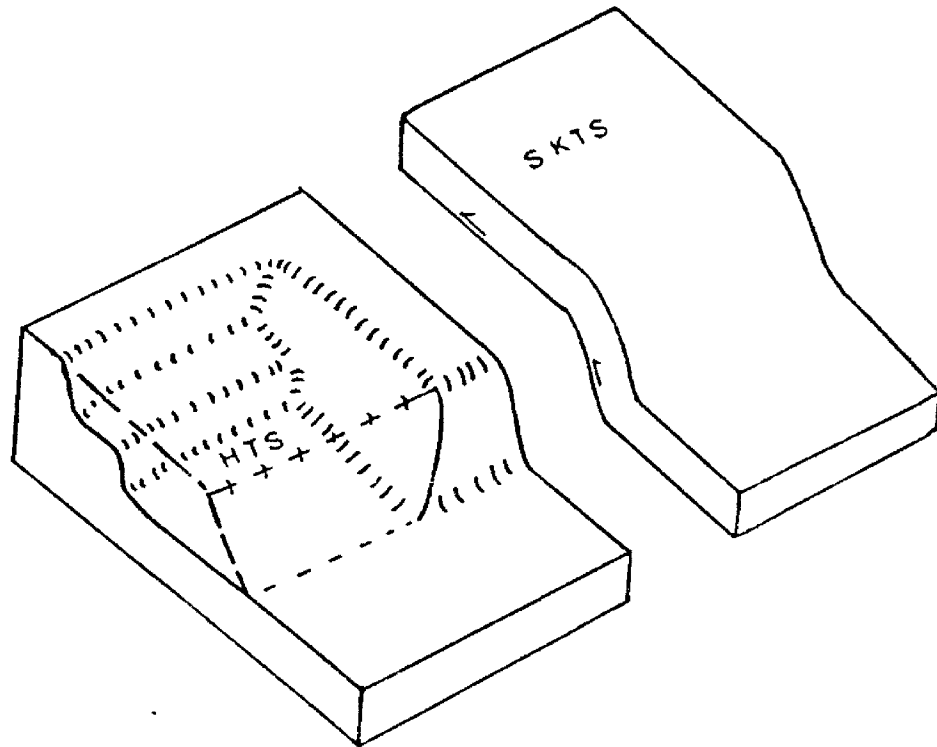
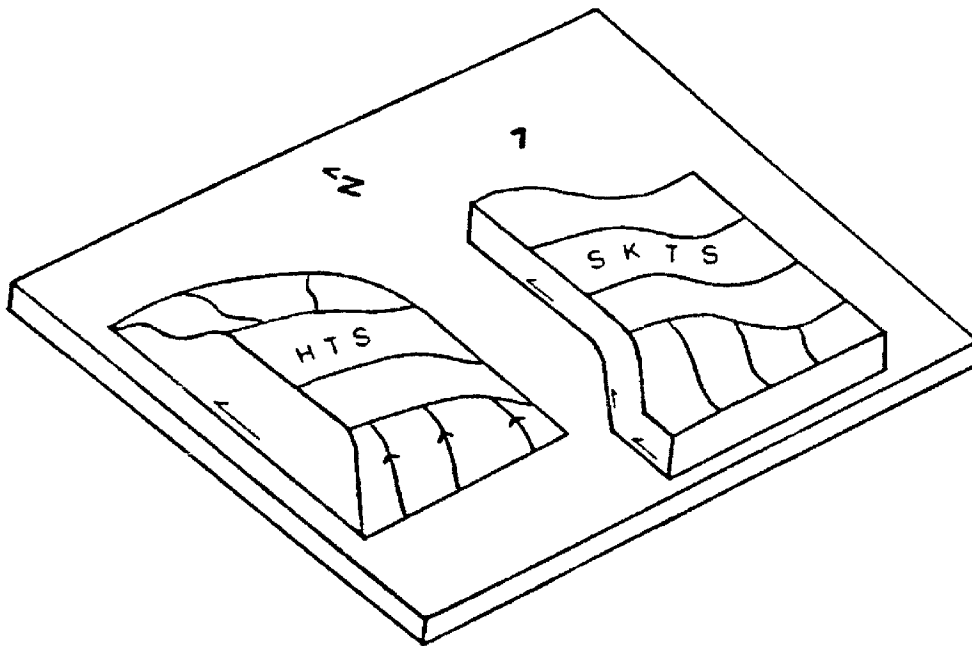
Fork segment. This structural continuity consequently demands domain 3 east of the Bighorn Creek segment was displaced farther northeastward than domain 2 because it is part of the Landers Fork segment hanging wall. The second constraint stems from the structural geometry at the north end of the Bighorn Creek segment. The segment does not offset domain 1 rocks there, both the Silver King and Hoadley thrust sheets lie on unfaulted Devonian rocks. Consequently, the fault must be superficial. These two constraints are met by interpreting the fault as either a transverse fault separating an overriding thrust sheet from a thrust sheet cut from the footwall (Fig. 19), or a tear fault.

The model of a transverse fault bounding a thrust sheet cut from the footwall is particularly attractive because:

- 1) the Bighorn Creek syncline and Bighorn Creek cross fault developed simultaneously and are attributed to the same cause
- 2) geologic cross sections through the Bighorn Creek fault can readily be made to match the model
- 3) the model readily accounts for the differential displacement across the Bighorn Creek fault
- 4) the model provides a simple explanation for the intersection of the Bighorn Creek and Landers

Fork segments with the Lone Mountain normal fault  
As developed in chapter 4, the model requires that the Hoadley thrust surface propagated upsection forward and laterally from the base of a Silver King thrust footwall ramp (Fig. 36). The Hoadley thrust sheet was then cut from the footwall and transported with the overlying Silver King sheet onto a gently dipping thrust surface, producing an asymmetric anticline-syncline pair (Fig. 37). Erosion through the Silver King sheet exposed the Hoadley sheet and Bighorn Creek segment. The modelled post-erosional structure matches the geology of the Bighorn Creek area and is, from west to east (Figs. 37 and 5, sec. 4), asymmetric anticline or structural terrace, asymmetric syncline, east-dipping thrust fault, and relatively undeformed portion of the overriding thrust sheet. Differential displacement across the Bighorn Creek segment is merely accounted for by its continuation with the Falls Creek segment. The "intersection" of the Bighorn Creek and Landers Fork segments and Lone Mountain normal fault simply marks the bend of the Silver King thrust around the southeast corner of the Hoadley thrust sheet (Fig. 38). The Lone Mountain normal fault probably propagated southeastward from the sharp bend when the Landers Fork segment underwent extensional reactivation, which continued into

Figure 36. Bottom) Exploded view showing overriding Silver King thrust sheet and portion cut from footwall to form the Hoadley thrust sheet.  
Top) Relative structural positions of the Silver King and Hoadley thrust sheets and footwall domain (1) after transport onto a flat decollement.



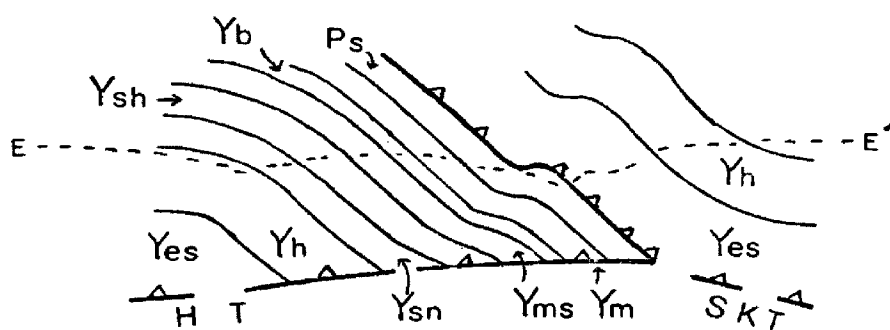


Figure 37. A) Pre-erosion, pre-extension model cross section through the Bighorn Creek syncline and fault segment along figure 5, sec. 4. Line E-E' is modern erosion surface.



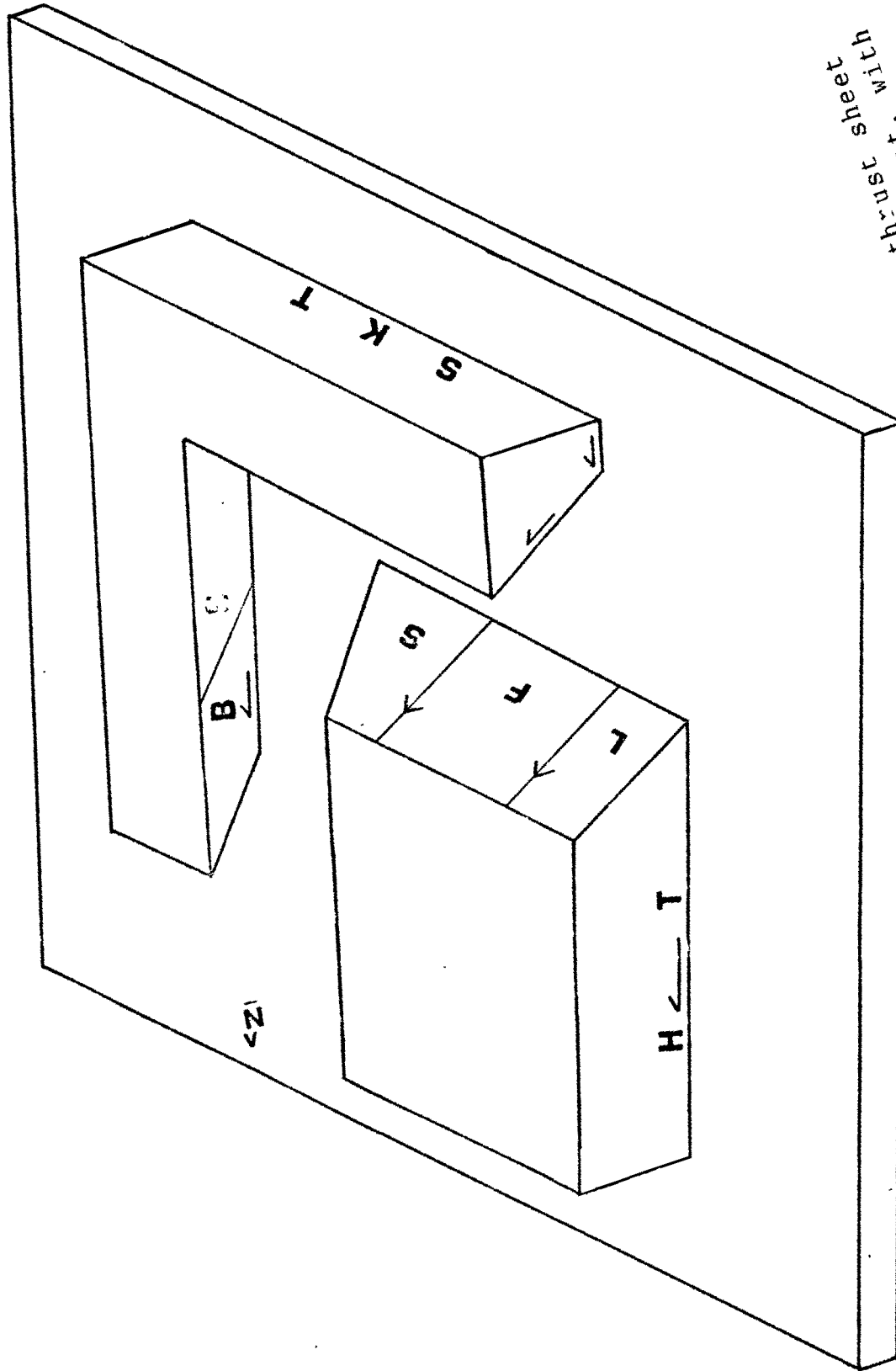


Figure 38. 3-D cartoon showing Silver King gung sheet, Hoopley sheet, and Tawfoot gung sheet. Both sheets continuously bonding the same gung sheets.

the Lone Mountain ramp monocline.

Conversely, tear fault interpretations of the Bighorn Creek segment are difficult to reconcile with the local and regional geology. A westward dipping tear fault interpretation has been rejected (see analysis of the Bighorn Creek syncline). A sinistral vertical tear fault interpretation is not supported by the map pattern of the faults. Because offset does not decrease to zero at the segment's southern end, this interpretation requires that the Lone Mountain normal fault was a continuation of the Landers Fork segment, on which the Silver King sheet overrode the Bighorn Creek segment. However, the Lone Mountain normal fault is not a reactivated thrust, therefore, the Bighorn Creek segment cannot be correctly interpreted as a vertical tear fault.

An eastward dipping tear fault interpretation is not supported by the regional geology. This interpretation requires that the Silver King thrust sheet overrode the Hoadley sheet on the Bighorn Creek segment with northwestward oblique slip, and therefore requires that movement on the Landers Fork segment was also northwestward (Fig. 39), which seems unlikely in light of the regional geology. Displacements of thrust sheets north of the study area are east-northeast

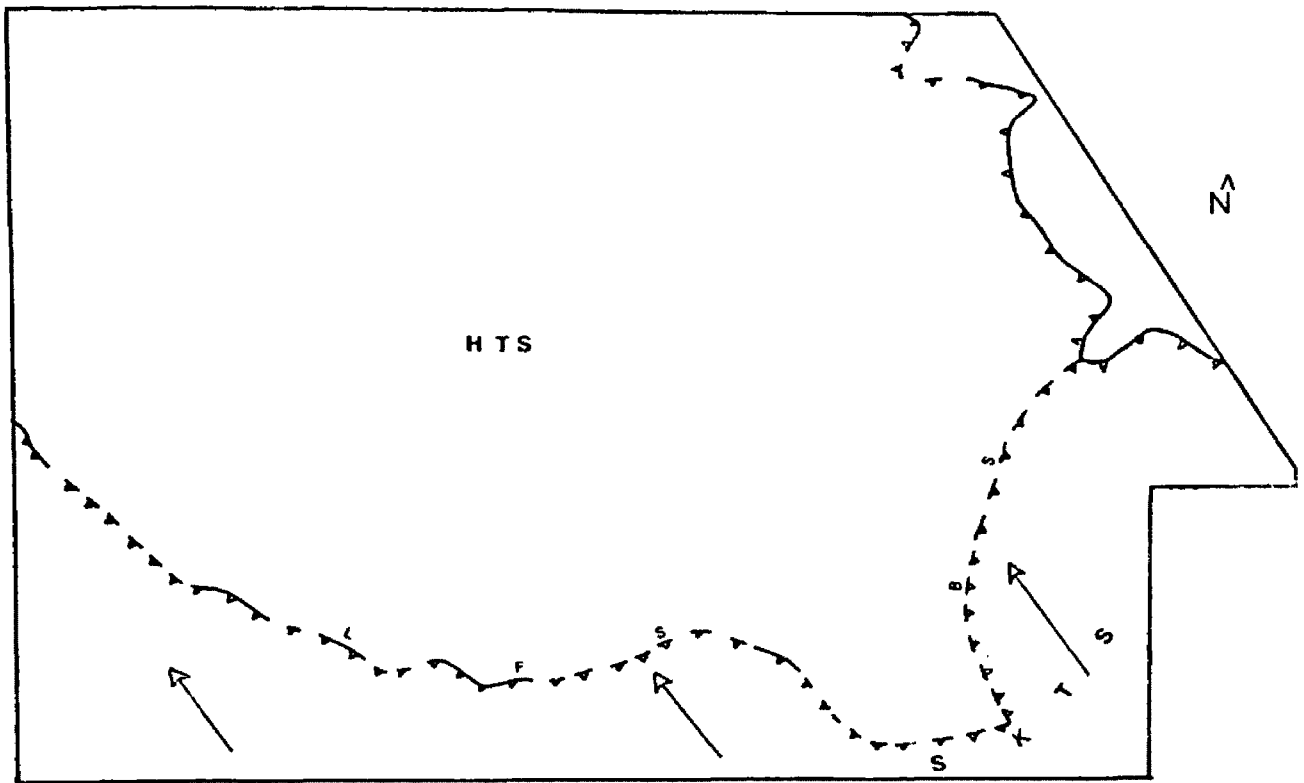


Figure 39. Map showing improbable transport direction of the Silver King thrust sheet that results if the Bighorn Creek segment is a tear fault with oblique northwestward offset.

(Mudge, 1972), and from the map pattern of the faults, are northeast in the southeastern Scapegoat region.

#### Implications for the Hoadley Thrust

This interpretation of the Bighorn Creek segment has major implications for the Hoadley thrust. Because the Silver King thrust sheet overlies the Hoadley sheet along the Bighorn Creek segment, the Hoadley thrust must plunge beneath the unfaulted intersection of the Bighorn Creek and Falls Creek segments, extending beneath the Silver King sheet only as far as the limited subsurface extent of the Hoadley sheet. (Fig. 5, sec. 5). The Hoadley and Silver King thrusts share the same footwall, but are not one continuous thrust as interpreted by all previous studies. To reflect more accurately the structural geology, I propose that the continuous fault comprised of the Landers Fork, Bighorn Creek, and Falls Creek segments, and its southeast continuation be named the Silver King thrust, for Silver King Mountain and the proposed addition to the Scapegoat Wilderness that is bounded on the north and west by the thrust fault.

#### Synthesis of Domain 3 Structure

The Silver King thrust sheet forms a structurally continuous southern and eastern bound of the Hoadley thrust sheet along the Landers Fork and Bighorn Creek segments (Fig. 38). The major internal structure of the Silver King sheet is the Lone Mountain ramp monocline, which continues westward as the southern limb of the Heart Lake syncline and is cut by the Lone Mountain and Lookout Creek normal faults. The Bighorn Creek segment is an east-dipping reverse fault which separates the Hoadley thrust sheet from the overriding Silver King sheet. This interpretation demands that the Hoadley thrust plunges beneath the Silver King thrust.

Extensional faults in the Silver King thrust sheet post-date thrust faults. The Blackfoot normal fault parallels the Landers Fork segment and probably joins it at depth. The Lone Mountain normal fault probably developed by extensional reactivation of the Landers Fork segment. The Lookout Creek normal faults developed within the Lone Mountain ramp monocline coevally with the Lone Mountain normal fault. Stratigraphic displacement on all the normal faults can be accommodated by dominantly horizontal extension without the need for footwall ramps or faults.

## CHAPTER 6

### STRUCTURAL EVOLUTION MODEL

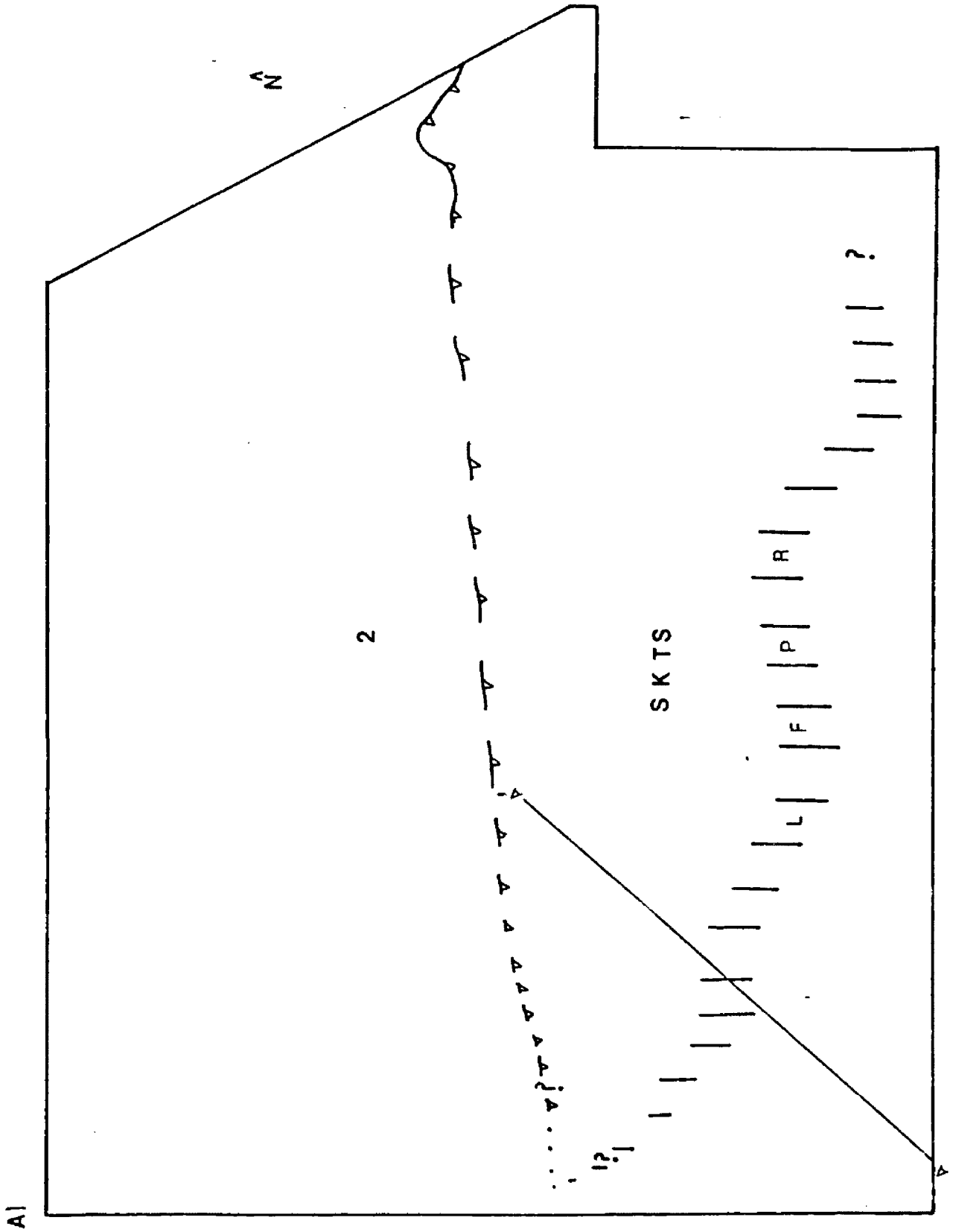
Any structural evolution model for the southeastern Scapegoat Wilderness must be constrained by the structural geometry developed in the preceding chapter. The most critical element is the Silver King thrust, which demands that the Silver King thrust sheet overrode, and consequently was displaced farther than the Hoadley sheet. Furthermore, major footwall faults or ramps are not reflected in any hanging wall structures and probably lie south and west of the map area. Therefore, the model interprets both the Silver King and Hoadley thrust sheets to lie on the same gently sloping decollement surface. Other constraints used in developing the model include: 1) thrust faults developed from southwest to northeast (hinterland to foreland) (Bally et al., 1966; Dahlstrom, 1970; Boyer and Elliot, 1982), and 2) overlap of the Silver King thrust sheet on the Hoadley sheet decreases to zero westward, because the Landers Fork segment, expressed as normal fault, dies out in the Swan Range.

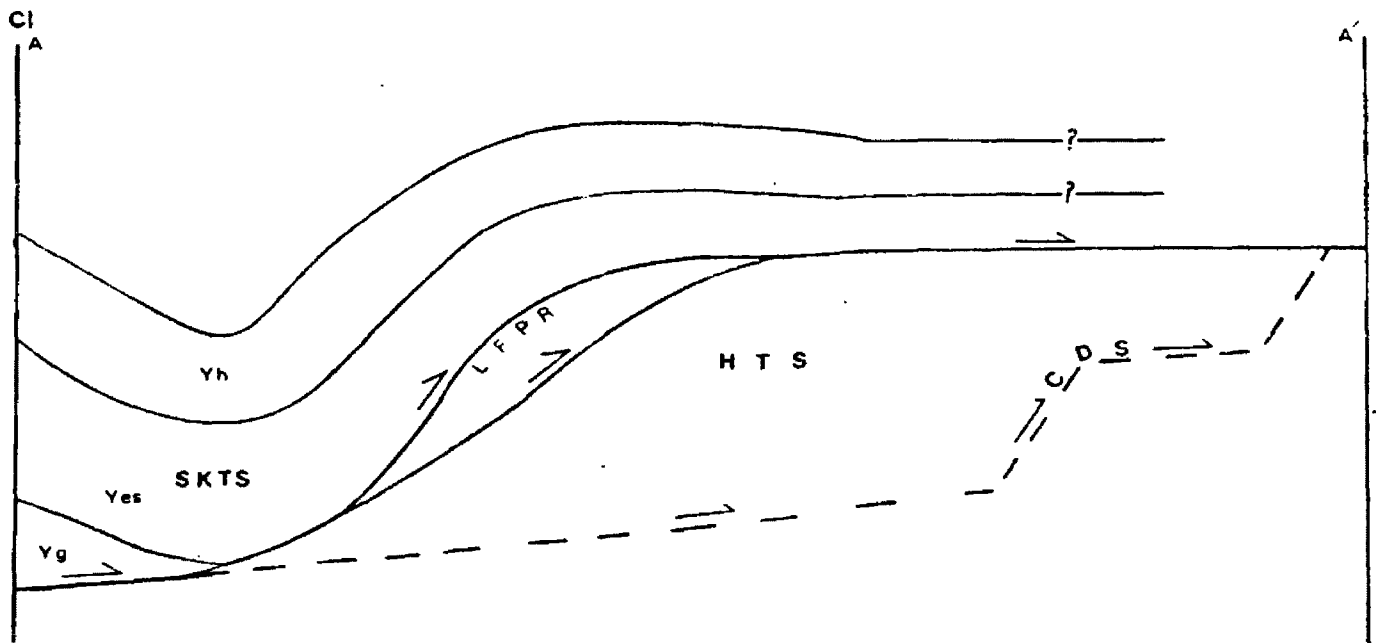
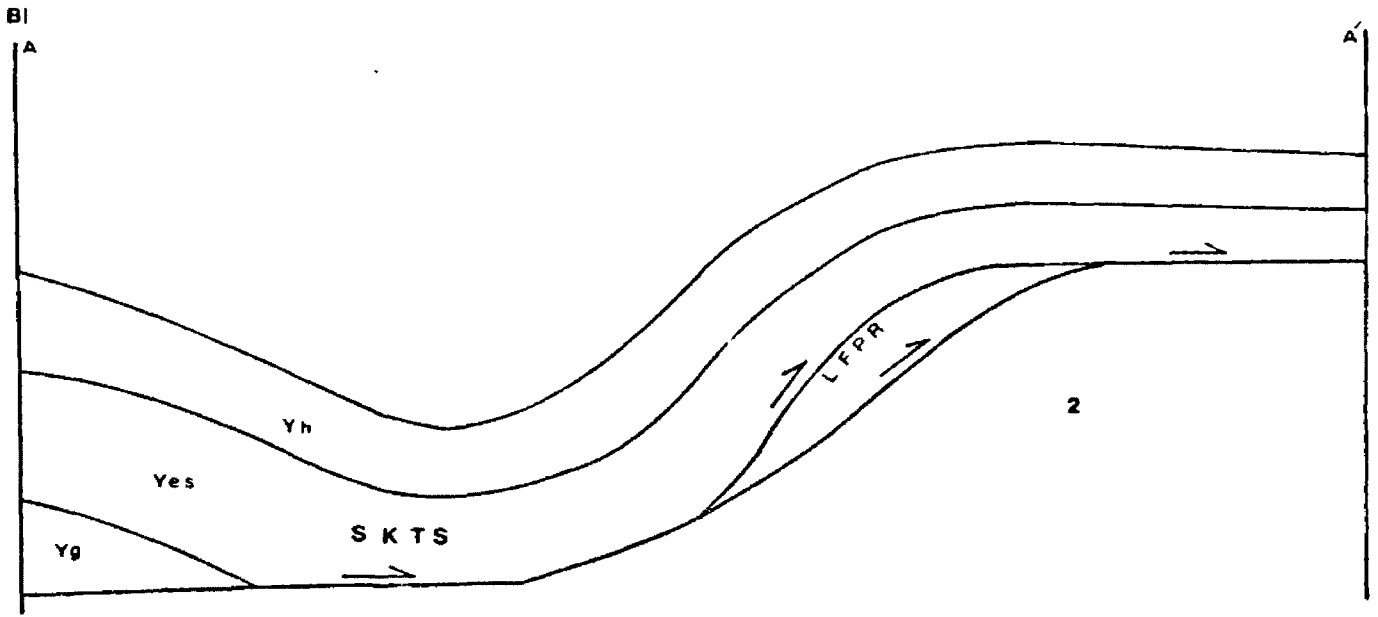
## The Model

The first stage in the Laramide structural evolution of the southeastern Scapegoat Wilderness was northeastward movement on the Silver King thrust (Fig. 40), that stepped up through two ramps. The southwest ramp cut from the Greyson up into the Empire-Spokane, forming the Lone Mountain ramp monocline and southern limb of the Heart Lake syncline. The northeastern ramp cut from the Empire Spokane up into lower Paleozoic rocks and is shown on figure 40 as the Landers Fork paleoramp. The horse containing the Twin Lakes area was probably plucked out of the footwall of the Landers Fork paleoramp during this stage. Impingement of the Lone Mountain ramp monocline on the footwall ramp (Fig. 40C) formed the Heart Lake syncline. The Hoadley thrust surface propagated forward from the base of the paleoramp. It cut upsection to the Mount Shields, followed the base of the Mount Shields, and then cut upsection again, either meeting the Silver King thrust surface, or rising in front of it. As the Hoadley thrust surface propagated forward, it also propagated laterally eastward and upsection along the ramp until it met the Silver King thrust surface (Fig. 36). The Hoadley thrust sheet was cut from the footwall and

- Figure 40. A) Paleotectonic map of the study area with Silver King thrust sheet displaced over autochthonous domain 2. The present location of the Landers Fork paleoramp is denoted by vertical lines (LFPR). Cross-section line denotes the location of model cross sections 40B and 40C.
- B) Model cross section of Silver King sheet overriding domain 2. Lone Mountain ramp monocline nearing Landers Fork segment paleoramp.
- C) Model cross section of the ramp monocline impinging on the Landers Fork segment paleoramp and initiating the Hoadley thrust, which stepped upsection to form Continental Divide syncline hanging wall ramp (CDS).







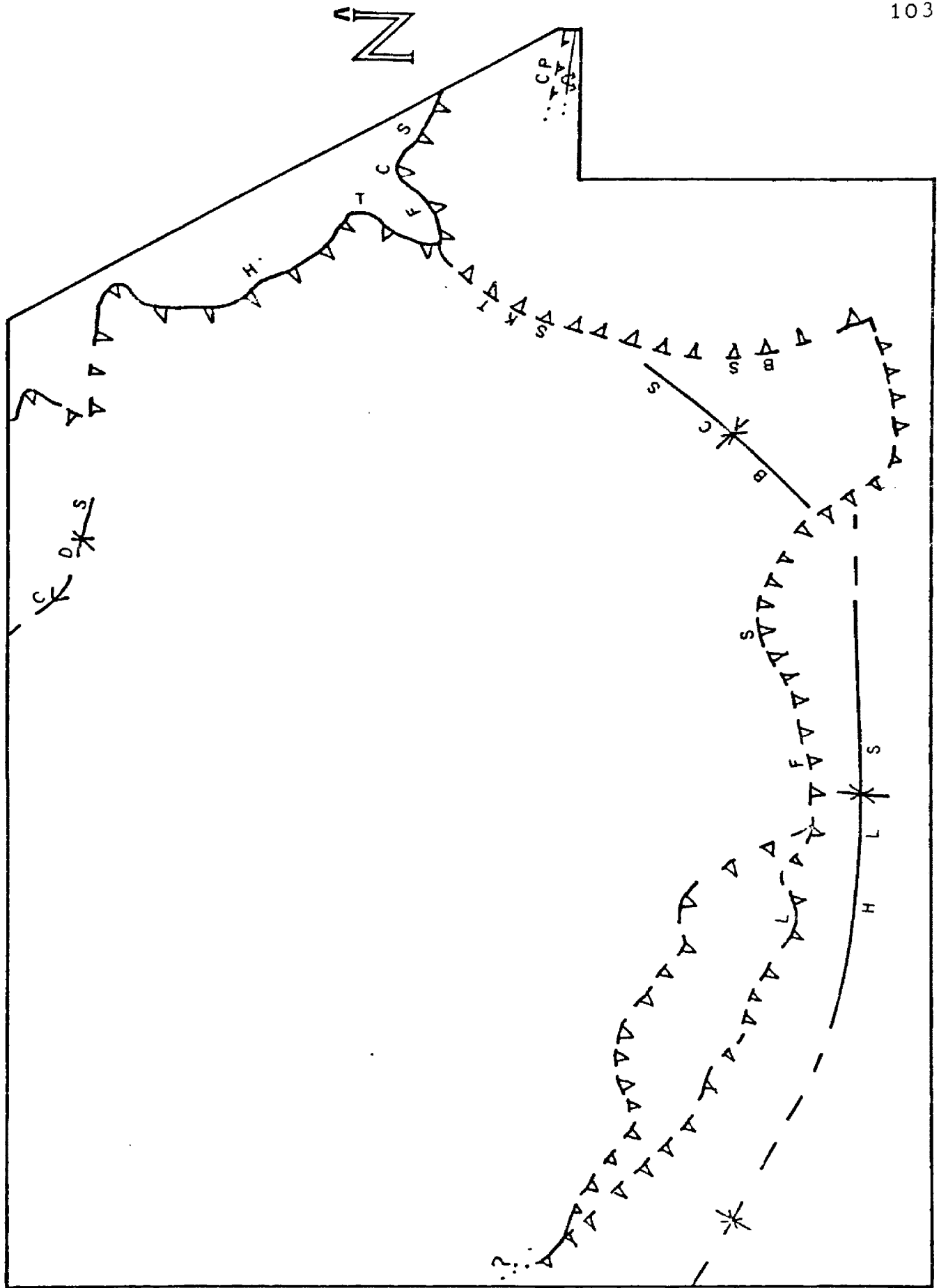
transported with the overlying Silver King thrust sheet onto a gently sloping thrust surface. Erosion through the Silver King sheet exposed the Bighorn Creek and Landers Fork segments, and the Continental Divide and Bighorn Creek synclines (Fig. 41), which resulted from the step-wise forward and lateral propagation of the Hoadley thrust respectively. The Hoadley thrust also cut through a pre-existing anticline north of the Bighorn Creek syncline.

#### Implications for Horizontal Displacement

This model establishes minimum horizontal displacement values for the Silver King and Hoadley thrust sheets in the southeastern Scapegoat Wilderness. The minimum overlap of the Silver King thrust sheet on the Hoadley sheet in the eastern part of the study area is the length of the Bighorn Creek segment, 8 km. Transport of both thrust sheets onto the same gently sloping decollement requires an additional 8 km of horizontal displacement (Fig. 42), yielding total horizontal displacements of 16 km for the Silver King sheet and 8 km for the Hoadley sheet.

Greater displacements can be inferred from local geology. The ramp monocline forming the southern

Figure 41. Post-thrusting, pre-extensional faulting paleotectonic map of the study area.



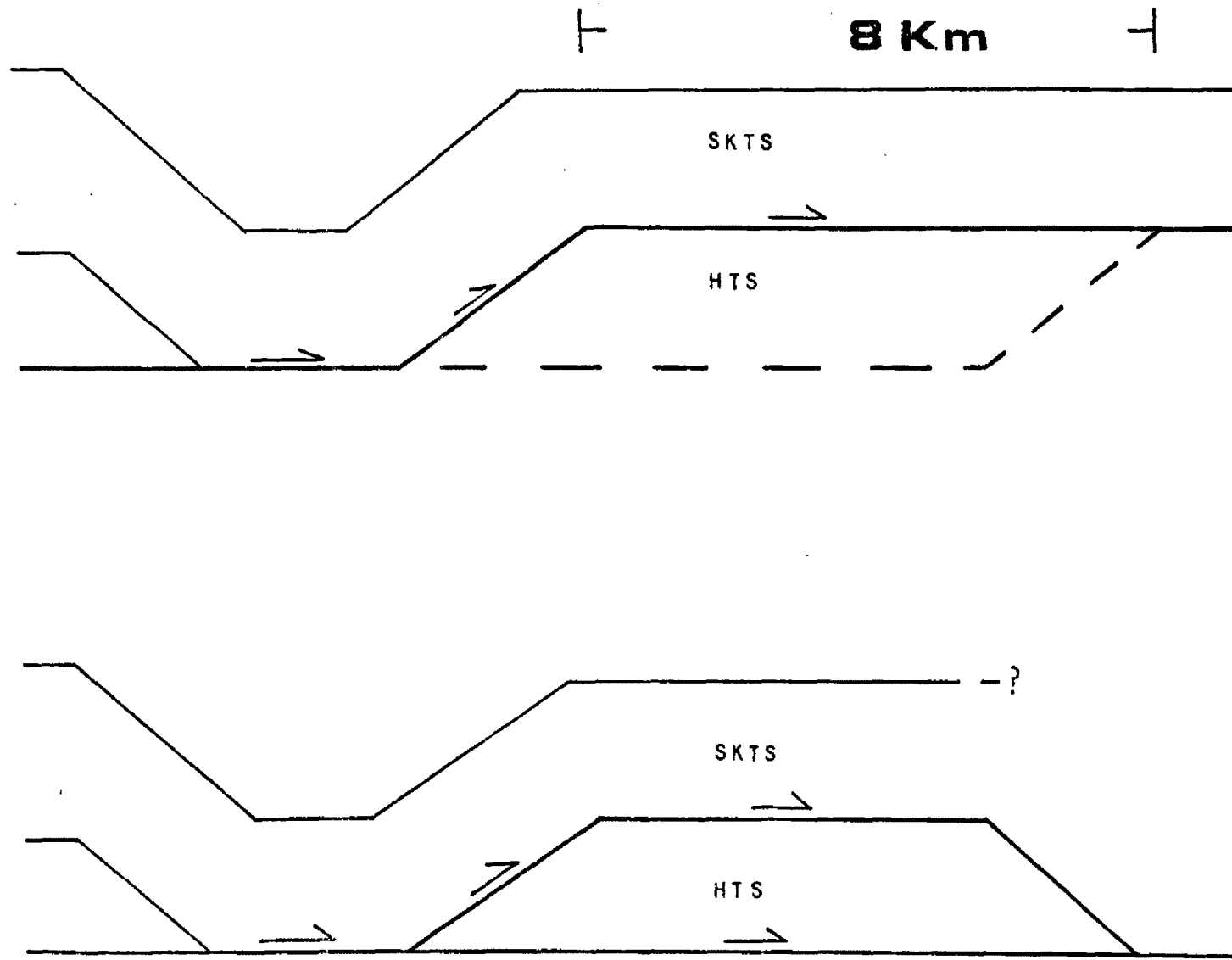


Figure 42. Model cross sections showing minimum 8 Km displacement of the Silver King thrust sheet over the Hoadley sheet, and a minimum of 8 more km to transport both sheets onto a nearly level footwall.

limb of the Continental Divide syncline, and the Lone Mountain ramp monocline required footwall ramps of considerable relief to form them (Figs. 31 and 32). Major footwall ramps are commonly the locii of Tertiary listric normal faults (Dahlstrom, 1970; Royse et al., 1975). Assuming displacement of the Silver King and Hoadley thrust sheets in the southeastern Scapegoat was northeastward, the nearest normal fault to the southwest with large stratigraphic offset bounds the north side of the Lincoln Valley, which is 30 km southwest of the Falls Creek segment. Therefore, 30 and 22 km are reasonable estimates of the minimum horizontal displacement of the Silver King and Hoadley thrust sheets respectively. Also, Sears (1983) proposed that a crustal-scale ramp was located in the Lincoln area during the development of the northwest Montana thrust and fold Belt. If this major ramp was a composite of several smaller ramps, it could have produced both the Continental Divide syncline and Lone Mountain ramp monoclines. Furthermore, significant horizontal displacement is reflected by the imbricate thrusting in the disturbed belt, which forms the footwall of the Hoadley and Silver King thrust faults.

## Effects of Pre-Thrusting Structure

Throughout the development of the structural evolution model, no mention or analysis was made of the effects of pre-thrusting structure, primarily because the model is based on geometric, not genetic analysis. However, Winston et al.(1982, ms) proposed that Laramide thrusting in the Scapegoat area was influenced by an east-west trending, southside down, syn-depositional Proterozoic basement fault. Based on abrupt stratigraphic thickening, the fault was tentatively located beneath the Landers Fork segment, and named the Jocko line because of its proposed continuation westward into the Jocko River Valley.

I propose the ramp which formed the Lone Mountain ramp monocline was located over this fault. In the southeastern Scapegoat strata thickens markedly within the Lone Mountain ramp monocline (Figs. 32C and 35), implying the ramp which formed the monocline was localized over a syn-depositional fault south of the study area. How far south depends on the horizontal displacement of the Silver King thrust sheet, which is not tightly constrained. My interpretation of the role of this fault in the structural development of the southeastern Scapegoat Wilderness differs from that



proposed by Winston et al.(1982, ms). They proposed that the Landers Fork segment was localized over this Proterozoic syn-depositional basement fault, then cut by the Hoadley thrust. Because the ramp monocline that formed over this basement fault is south of the Landers Fork segment, the segment was located north of, not directly over, the fault. My refinement is more consistent with the present structural geometry.

### Extensional Faulting

Most extensional faults are concentrated in or near structures that formed during thrusting of the Silver King and Hoadley sheets. During Tertiary extension, the Landers Fork segment was reactivated, and the Blackfoot normal fault developed as a splay from it (Fig. 5, sec. 1). Extensional offset transferred from the eastern end of the Landers Fork segment into the Lone Mountain ramp monocline, producing the Lone Mountain and Lookout Creek normal faults. The western segment of the Cooney Creek fault, and the eastern segments of the Cooney Creek and Red Ridge faults developed in or along fold limbs probably weakened by folding (Fig. 5). On the other hand, the western segment of the Red Ridge fault reflects no pre-existing structure.

The Landers Fork segment, Continental Divide and Bighorn Creek synclines, and Lone Mountain ramp monocline are interpreted as superficial structures confined within the Silver King and Hoadley thrust sheets. The direct spatial correlation of the Blackfoot, Cooney Creek, Red Ridge, Lone Mountain, and Lookout Creek extensional faults with these structures supports the interpretation that these faults are listric (Fig. 5, secs. 1, 3, and 4) and join a common decollement at depth.

#### Magnitude of Extension

The magnitude of extension within the southeastern Scapegoat is not closely determined. Beside stratigraphic offset, the amount of extension on a fault depends on its subsurface dip, which is not constrained in the study area. Extension across the Cooney Creek, Red Ridge, and Blackfoot faults in Fig. 5, sec. 1 can be as small as 2 km, a geologically reasonable value. Lack of well developed rollover anticlines in the hanging wall of normal faults suggests total extension across the map area of a few kilometers or less.

## Summary of Structural Evolution

The Cretaceous to Early Tertiary structures of the southeastern Scapegoat Wilderness evolved as the Silver King and Hoadley thrusts, cutting up through Belt strata, moved from southwest to northeast. The Landers Fork segment footwall is a paleoramp on which the Silver King thrust sheet overrode autochthonous domain 2 (Fig. 40) until the Lone Mountain ramp monocline impinged on the paleoramp, initiating a forward and lateral upsection propagation of the Hoadley thrust surface from the paleoramp's base (Figs. 36 and 40C). The Hoadley and overlying Silver King thrust sheets were then transported onto a gently dipping footwall. Erosion of the Silver King thrust sheet exposed the Bighorn Creek and Landers Fork segments and Hoadley thrust sheet. This model demands a minimum of 16 and 8 km horizontal displacement of the Silver King and Hoadley thrust sheets, respectively (Fig. 42). Total displacement, which includes displacement of the thrust sheets of domain 1, was probably greater.

The Lone Mountain ramp monocline formed over a southside-down syn-depositional Proterozoic basement fault, the Jocko Line (Winston et al., 1982, ms), over which Belt strata thickened abruptly and the later

Silver King thrust surface deflected upward (Fig. 10). Tertiary extensional faulting in the southeastern Scapegoat was also affected by pre-existing structure. Extension reactivated the Landers Fork segment, and normal faults developed along or in ramp monoclines. The correspondence of extensional faults with superficial thrust structures suggests the extensional faults are also superficial.

CHAPTER 7  
IMPLICATIONS AND CONCLUSIONS

Implications

The results of this study have both geologic and economic implications for the Montana thrust and fold belt. They are:

- 1) Displacement of the Hoadley and Silver King thrusts was not hinged to the north
- 2) Proterozoic structure definitely influenced Laramide thrusting in the southeastern Scapegoat, and possibly in other areas of the Belt basin
- 3) The Silver King and Hoadley thrusts could be roof thrusts to a large duplex structure
- 4) Thrust sheets with ramp monoclines are probably much thinner than the thickness of strata exposed in the sheet
- 5) Thin thrust sheets of Belt rocks increase the fold and thrust belt's hydrocarbon potential

The structural history interpreted here explains the structure of the southeastern Scapegoat with unidirectional northeast transport of the Hoadley and Silver King thrust sheets. This substantiates Winston's

(1985) and Sear's (1983) proposals that thrust displacement in this area was northeastward, and refutes Mudge and Earhart's (1980) interpretation that the Hoadley and Silver King thrusts are one fault whose displacement was hinged to the north.

Pre-thrusting structure clearly influenced the Laramide structural development of the southeastern Scapegoat. Again, this substantiates proposals by Winston (1985) and Sears (1983) that Proterozoic basement structure influenced thrust belt development in this area. Ramp monoclines resulting from upsection deflections of thrust surfaces over Proterozoic basement faults probably occur elsewhere in the northwest Montana thrust and fold belt, and they could have played important roles in initiating thrust propagation from the bases of ramps, and also be the locii of normal faults.

Several aspects of the Hoadley and Silver King thrust sheets suggests that they are roof thrust sheets of a duplex structure. They contain gently dipping strata and probably lie on nearly horizontal thrust surfaces (Fig. 5), which is characteristic of duplex roof thrust sheets (Boyer and Elliot, 1982). Furthermore, the structural position of the Hoadley and Silver King thrust sheets with respect to the disturbed

belt is identical to that of the Lewis Thrust sheet. Boyer and Elliot (1982) offered strong evidence that the Lewis is a roof thrust and the underlying disturbed belt an exposed portion of the imbricate horses internal to the duplex. This structural similarity strongly suggests the Hoadley and Silver thrust sheets are the southeastward continuation of the roof of Lewis duplex structure.

Ramp monoclines make stratigraphic thickness within a thrust sheet a highly erroneous indicator of its structural thickness. With enough erosion, ramp monoclines enable a thick stratigraphic section to be exposed in a structurally thin thrust sheet (Fig. 43). The southeastern Scapegoat is an example (Fig. 5 sec. 1); 8 km of Paleozoic and Belt strata is exposed in the Silver King and Hoadley thrust sheets which can reasonably be interpreted as 4 km thick.

The implication for economic geology is based on the consequences of ramp monoclines. Belt rocks are not hydrocarbon producers, therefore Phanerozoic rocks must be below Belt thrust sheets to make this area attractive for hydrocarbon exploration. A thin thrust sheet leaves room for Phanerozoic rocks between itself and basement. The depth to basement in the southeastern Scapegoat is unpublished, but along structural strike to the

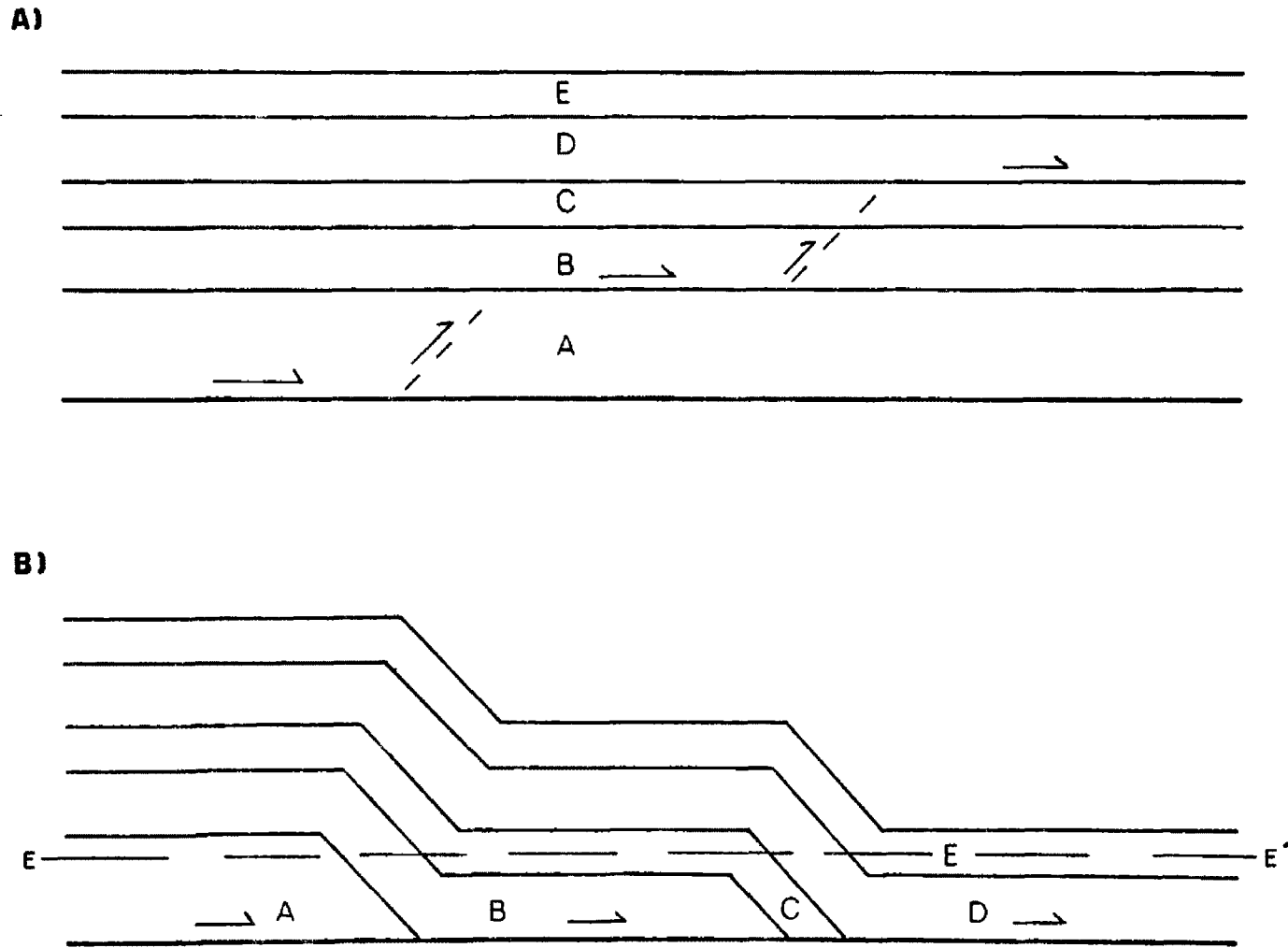


Figure 43. Model cross section of a thrust sheet which contains two ramp monoclines that when eroded (line E-E') exposes the complete stratigraphic section.



northwest, Mudge (1972) estimated a depth to basement of 8 km, a reasonable estimate for the southeastern Scapegoat. The Hoadley thrust sheet is interpreted as 3 km thick in the center of the map area (Fig. 5, sec. 1), implying the basement is 5 km below the base of the thrust sheet, providing room for a thin partial Belt section and significant amount of Phanerozoic strata which might contain hydrocarbons.

### Conclusions

By analyzing structures within the southeastern Scapegoat using known "rules" of foreland thrust and fold belt geometry, I deciphered probable subsurface geometries of the structures and developed a Laramide structural evolution model for the area. The major folds and thrusts developed from hinterland to foreland and directly resulted from paths the Silver King and Hoadley thrusts cut through Belt strata. Seismic profiling and/or drilling would more accurately constrain the three-dimensional geometry of the Silver King and Hoadley thrust sheets in the southeastern Scapegoat Wilderness, but it is not open to these activities. Seismic profiling has been actively carried out in the surrounding non-wilderness areas. These

seismic data will improve interpretation of the study area structure, especially structure below the Silver King and Hoadley thrust sheets.

The results of this study have implications for the local and regional structural geology. Locally, the Silver King and Hoadley thrust sheets probably underwent unidirectional northeast transport in the southeastern Scapegoat, and their structural development was influenced by a syn-depositional Proterozoic basement fault, the Jocko line. The Silver King and Hoadley thrust sheets have characteristics common to thrust sheets overlying duplexes. Ramp monoclines within the thrust sheets suggest they are thin, and significant amounts of hydrocarbon bearing Phanerozoic rocks could lie beneath them. Regionally, this method of analysis and these implications are important to deciphering the structural development of other thrust sheets in similar structural settings within the Belt basin, such as the Lewis and Eldorado sheets.

## REFERENCES CITED

- Allmendinger, R.W., Structural geology of the Meade thrust plate in northern Blackfoot Mountains, southeastern Idaho: AAPG Bull., v.65, p.509-525.
- Bally, A.W., P.L. Gordy, and G.A. Stewart, 1966, Structure, seismic data, and orogenic evolution of the southern Canadian Rocky Mountains: Bull. Canadian Petroleum Geology, v.14, p.337-381.
- Boyer, S.E., 1978, Structure and origin of the Grandfather Mountain window, North Carolina: PhD thesis, John Hopkins Univ.
- Boyer, S.E. and D. Elliot, 1982, Thrust systems: AAPG Bull., v.66, p.1196-1230.
- Clapp, C.H., 1932, Structure of a portion of the Rocky Mountains of northwestern Montana: Montana School of Mines Mem.4.
- \_\_\_\_\_, 1934, Structure of Coopers Lake quadrangle, Montana (abs.): Geol. Soc. America Proc. 1933, p.72.
- \_\_\_\_\_, and C.F. Deiss, 1931, Correlations of Montana Algonkian formations: Geol. Soc. America Bull., v.42, p.673-696.
- Constenius, K.N., 1981, Stratigraphy, sedimentation, and tectonic history of the Kishenehn Basin, northwestern Montana: MS thesis, Univ. Wyoming.
- Dahlstrom, C.D.A., 1970, Structural geology in the eastern margin of the Canadian Rocky Mountains: Bull. Canadian Petroleum Geology, v.18, p.332-406.
- Deiss, C.F., 1933, Paleozoic formations of northwestern Montana: Montana Bur. Mines and Geology Mem.6.
- \_\_\_\_\_, 1939, Cambrian stratigraphy and trilobites of northwestern Montana: Geol. Soc. America Spec. Paper 18.
- \_\_\_\_\_, 1943, Stratigraphy and Structure of the southwest Saypo quadrangle, Montana: Geol. Soc. America Bull., v.54, p.205-262.

- Douglas, R.J.W., 1952, Preliminary map, Waterton, Alberta: Canada Geol. Survey Paper 51-22.
- Earhart, R.L., D.J. Grimes, R.W. Leinz, and L.Y. Marks, 1977, Mineral resources of the proposed additions to the Scapegoat wilderness, Powell and Lewis and Clark counties, Montana, with a section on geophysical surveys by D.L. Peterson: U.S. Geol. Survey Bull. 1430.
- Eby, E.E., 1977, Sedimentation and early diagenesis within eastern portions of the "Middle Belt Carbonate Interval" (Helena Formation), Belt Supergroup (Precambrian Y), western Montana: PhD thesis, State Univ. of New York at Stony Brook.
- Funk, J.L., 1967, Geology of the Landers Fork of the Blackfoot River area, Montana: Missouri Univ. MS thesis.
- Hoffman, J., J. Hower, and J.L. Aronson, Radiometric dating of time of thrusting in the disturbed belt of Montana: Geology, v.4, p.16-20.
- McGill, G.E., and D.A. Sommers, 1967, Stratigraphy and correlation of the Precambrian Belt Supergroup of the southern Lewis and Clark Range, Montana: Geol. Soc. America Bull., v.78, p.343-352.
- Mudge, M.R., 1970, Origin of the disturbed belt in northwestern Montana: Geol. Soc. America Bull., v.81, p.337-392.
- \_\_\_\_\_, 1972, Structural geology of the Sun River Canyon and adjacent areas, northwestern Montana: U.S. Geol. Survey Prof. Paper 663B.
- \_\_\_\_\_, and R.L. Earhart, 1980, The Lewis thrust fault and related structures in the disturbed belt, northwestern Montana: U.S. Geol. Survey Prof. Paper 1174.
- \_\_\_\_\_, \_\_\_\_\_, E.T. Tucheck, and W.L. Rice, 1974, Mineral resources of the Scapegoat Wilderness, Powell and Lewis and Clark Counties, Montana with a section on geophysical surveys by D.L. Peterson: U.S. Geol. Survey Bull. 1385-B.

-

- \_\_\_\_\_, \_\_\_\_\_, J.W. Whipple, and J.E. Harrison, 1983, Geologic and structure maps of the Choteau 1 X 2 quadrangle, northwestern Montana: Montana Bur. Mines and Geology Map MA-3A.
- \_\_\_\_\_, R.L. Erickson, and D. Kleinkopf, 1968, Reconnaissance geology, geophysics, and geochemistry of the southeastern part of the Lewis and Clark range, Montana, with spectographic data, by R.E. Zartman: U.S. Geol. Survey Bull. 1252-E.
- Price, R.A., 1965, Flathead map-area, British Columbia and Alberta: Geol. Survey Canada, Mem.336.
- Rich, J.L., 1934, Mechanics of low-angle overthrust faulting illustrated by the Cumberland thrust block, Virginia, Kentucky, and Tennessee: AAPG Bull., v.18, p.1584-1596.
- Royse, F., M.A. Warner, and D.C. Reese, 1975, Thrust belt structural geometry and related stratigraphic problems, Wyoming, Idaho, and northern Utah: Rocky Mtn. Assoc. Geologists Symp., p.41-54.
- Sears, J., 1983, A continental margin ramp in the cordilleran thrust belt along the Montana lineament: Geol. Soc. America Abs. with Programs, v.15, p.682.
- Sloss, L.L., and W.M. Laird, 1946, Devonian stratigraphy of central and northwestern Montana: U.S. Geol. Survey Oil and Gas Inv. Prelim. Chart 25.
- Smith, R.B., and M.L. Sbar, 1974, Contemporary tectonics and seismicity of the western United States with emphasis on the intermountain seismic belt: Geol. Soc. America Bull., v.85, p.1205-1218.
- Thomas, W.A., 1983, Basement-cover relations in the Appalachian fold and thrust belt: Geological Journ. v.18, p.267-276.
- Walcott, C.D., 1906, Algonkian formations of northwestern Montana: Geol. Soc. America Bull., v.17, p.1-28.
- \_\_\_\_\_, 1908, Cambrian sections of the Cordilleran area: Smithsonian Misc. Colln. 53, p.167-230.
- \_\_\_\_\_, 1910, Abrupt appearance of the Cambrian fauna on

the North American continent: Smithsonian Misc. Colln., v.13, p.305-352.

White, B.G., 1978, Thrusting in the northwestern Montana overthrust belt: PhD thesis, Univ. of Montana.

Wilson, C.W.Jr., and R.G. Stearns, 1958, Structure of the Cumberland Plateau, Tennessee: Geol. Soc. America Bull., v.10, p.1283-1296.

Wiltschko, D., and D. Eastman, 1983, Role of basement warps and faults in localizing thrust ramps, in Hatcher, J.D. Jr., H. Williams, and I. Zeitz, eds., Contributions to the tectonics and geophysics of mountain chains: Geol. Soc. America Mem. 158, p.177-190.

Winston, D., 1985, Tectonics and sedimentation of the Middle Proterozoic Belt Basin, and their influence on Cretaceous compression and Tertiary extension in western Montana and northern Idaho, in Peterson, J., ed., Tectonics and sedimentation of the Rocky Mountains: AAPG Mem., in press.

Winston, D., P. Jacob, D.O. Baldwin, and J.P. Reid, 1982, Proterozoic block faulting in the Belt basin, Montana and Idaho, its effect on Rocky Mountain thrusting and Basin and Range extension: unpublished man.

## APPENDIX 1

## Lithologic Descriptions of Belt Units

Most descriptions come from outcrops north of the Landers Fork segment and Lone Mountain normal fault (Fig. 2). South of these faults, Mudge et al.'s (1974) mapping was locally checked for accuracy, but the rocks were not described. Thicknesses and their locations for all units except the McNamara are given in table 1 and figure 3.

## Empire-Spokane Formations

The Empire and Spokane formations were mapped as one unit within the southeastern Scapegoat. These formations crop out in the upper Bighorn Creek drainage and are poorly exposed in an inlier through the Helena Dolomite in the upper and lower Landers Fork drainage. The Empire-Spokane has been metamorphosed to a brown and gray easily weathered hornfel by the intrusion of a Late Precambrian ( Mudge et al, 1974 ) diabase sill. In the upper Landers Fork area only the transition zone between the Empire-Spokane and overlying Helena Dolomite is exposed. Here the Empire-Spokane is tan to buff weathering, brown, green, and gray calcareous siltite

-

with occasional thin beds of white to clear quartzite. The contact between the Empire-Spokane and Helena dolomite was placed at the base of the first persistent carbonate beds which weather to tan and yellow.

#### Helena Dolomite

The Helena Dolomite is exposed throughout the eastern and northern parts of the southeastern Scapegoat Wilderness. The Helena is a gray, dominantly thin to medium-bedded, sometimes limey silty dolomite which weathers to tan and yellow. Near Caribou Peak the upper Helena is thickly bedded to massive. Stromatolites, oolites, and flat pebble conglomerate are common in the middle and upper parts of the Helena. The contact with the overlying Snowslip Formation was placed at the abrupt lithologic and color change from gray silty dolomite to red siltite and quartzite.

#### Snowslip Formation

The Snowslip crops out throughout the southeastern Scapegoat Wilderness except in the Red Ridge area. The Snowslip is a red, locally green or purple, siltite and quartzite. It is composed mostly of thin tabular sets of fine to medium-grained, horizontally laminated quartzite interbedded with thinly bedded siltite



couplets. The Snowslip is micaceous on all bedding surfaces. Stromatolites occur at several levels within the Snowslip, and a thick bed of stromatolites occurs near the top of the formation. The contact between the Snowslip and overlying Shephard Formation was placed at the lithologic and color change from red siltite and quartzite to yellow weathering silty dolomite.

### Shephard Formation

The Shephard Formation is exposed on the divide between the upper reaches of Bighorn Creek and the Landers Fork; west, north, and northwest of Red Ridge, and south of the Tobacco Valley. The Shephard is a gray thinly bedded dolomitic siltite and silty dolomite which weathers to a distinctive yellow. It contains ripple marks, load casts, and stromatolites. Throughout the study area a fissile black argillite unit several meters thick with an underlying stromatolite bed is present near the base of the formation. Near the top the Shephard contains medium-grained glauconitic quartzite beds and 0.1 to 1 m thick beds of siltite-argillite couplets. The contact between the Shephard and overlying Mount Shields Formation was placed at the bottom of the first pervasive red siltite.

-

## Mount Shields Formation

The Mount Shields Formation is exposed on the divide between Bighorn Creek and the Landers Fork, south of Tobacco Valley, and in the Red Ridge area, where the Mount Shields tops a large structural terrace which extends southward to the Landers Fork-East Fork of the Blackfoot drainage. The lower Mount Shields is a red micaceous siltite and very fine-grained quartzite with interbeds of fine to medium-grained quartzite. The middle Mount Shields is a medium to thickly bedded, horizontally laminated, occasionally cross-bedded, red-orange to tan, well rounded quartzite which grades into green siltite-argillite couplets with interbeds of tan fine-grained quartzite. Ripple marks and scour surfaces are common throughout the Mount Shields. The contact between the Mount Shields and overlying Bonner Quartzite is gradational and was placed at the top of the last bed of siltite-argillite couplets.

## Bonner Quartzite

The Bonner Quartzite is exposed south of Tobacco Valley, on Red Ridge at the tops Olsen and Pyramid peaks, and on the divide between Bighorn Creek and the Landers Fork. The Bonner is a white, pink, purple, and tan, well indurated, subangular to subrounded well

sorted quartzite with minor feldspar, red and black chert, and heavy minerals. It contains climbing ripple marks and cross-beds up to 1.1 m thick. The contact between the Bonner, a prominent ridge former, and the siltites and argillites of the overlying McNamara Formation is abrupt and topographically expressed.

#### McNamara Formation

The McNamara Formation crops out on the divide between Bighorn Creek and the Landers Fork, in a stream cut-bank in the Landers Fork drainage, and in the Tobacco Valley. The McNamara is green and red micaceous argillite and siltite with occasional interbeds of fine-grained quartzite which are glauconitic in the upper part of the formation. A lense of medium-grained, well rounded, well sorted, cross-bedded and horizontally laminated quartz quartz sandstone crops out on the divide between Bighorn Creek and the Landers Fork. The McNamara contains small ripple marks, mud chips, and load casts. It is 460 m thick in the west limb of the Bighorn Creek syncline. The contact between the McNamara and overlying resistant Middle Cambrian Flathead Sandstone is unconformable and topographically expressed.