

PIV measurements of the velocity field of a Newtonian fluid in a stirred tank equipped with the PMT type impeller

Story, Anna; Jaworski, Zdzislaw; Simmons, Mark; Nowak, Emilia

License:

Creative Commons: Attribution (CC BY)

Document Version

Publisher's PDF, also known as Version of record

Citation for published version (Harvard):

Story, A, Jaworski, Z, Simmons, M & Nowak, E 2014, 'PIV measurements of the velocity field of a Newtonian fluid in a stirred tank equipped with the PMT type impeller', *Technical Transactions*, vol. 24, no. 2, pp. 125-134.

[Link to publication on Research at Birmingham portal](#)

Publisher Rights Statement:

Website lists journal under free content journals and open access journals.

General rights

Unless a licence is specified above, all rights (including copyright and moral rights) in this document are retained by the authors and/or the copyright holders. The express permission of the copyright holder must be obtained for any use of this material other than for purposes permitted by law.

- Users may freely distribute the URL that is used to identify this publication.
- Users may download and/or print one copy of the publication from the University of Birmingham research portal for the purpose of private study or non-commercial research.
- User may use extracts from the document in line with the concept of 'fair dealing' under the Copyright, Designs and Patents Act 1988 (?)
- Users may not further distribute the material nor use it for the purposes of commercial gain.

Where a licence is displayed above, please note the terms and conditions of the licence govern your use of this document.

When citing, please reference the published version.

Take down policy

While the University of Birmingham exercises care and attention in making items available there are rare occasions when an item has been uploaded in error or has been deemed to be commercially or otherwise sensitive.

If you believe that this is the case for this document, please contact UBIRA@lists.bham.ac.uk providing details and we will remove access to the work immediately and investigate.

ANNA STORY*, ZDZISŁAW JAWORSKI*, MARK SIMMONS**, EMILIA NOWAK**

PIV MEASUREMENTS OF THE VELOCITY FIELD OF A NEWTONIAN FLUID IN A STIRRED TANK EQUIPPED WITH THE PMT TYPE IMPELLER

POMIARY PIV POLA PRĘDKOŚCI CIECZY NEWTONOWSKIEJ W MIESZALNIKU Z MIESZADŁEM TYPU PMT

Abstract

The paper presents the results of Particle Image Velocimetry (PIV) measurements of the velocity field of a Newtonian fluid in a mixing tank equipped with a PMT type impeller. The results are presented in the form of the velocity vectors, profiles and maps and compared with available data in the literature for the corresponding system, obtained from Laser Doppler Anemometry (LDA) measurements. A good qualitative agreement of the results was found. In the flow one primary and two secondary circulation loops were observed. The PMT type impeller produced a typical axial-radial circulation of the liquid in the vessel. The value of the circulation flow number, K_c , was calculated.

Keywords: PIV, PMT impeller, velocity field, circulation flow number

Streszczenie

W artykule przedstawiono wyniki pomiarów pola prędkości cieczy newtonowskiej w mieszalniku wyposażonym w mieszadło typu PMT, wykonanych za pomocą obrazowej anemometrii laserowej (PIV). Wyniki przedstawiono w postaci wektorów, profili i map prędkości średniej oraz porównano je z dostępnymi w literaturze danymi do analogicznego układu, otrzymanymi z pomiarów wykonanych metodą dopplerowskiej anemometrii laserowej (LDA). Stwierdzono dobrą zgodność jakościową wyników. W przepływie wyodrębniono jeden pierwotny i dwa wtórne wiry cyrkulacyjne. Mieszadło typu PMT wytwarzało typowo osiowo-promieniową cyrkulację cieczy w mieszalniku. Obliczono liczbę cyrkulacji cieczy, K_c .

Słowa kluczowe: PIV, mieszadło PMT, pole prędkości, liczba cyrkulacji

* M.Sc. Anna Story, Prof. Zdzisław Jaworski, Institute of Chemical Engineering and Environmental Protection Processes, Faculty of Chemical Technology and Engineering, West Pomeranian University of Technology, Szczecin.

** Prof. Mark Simmons, Ph.D. Emilia Nowak, School of Chemical Engineering, The University of Birmingham, Edgbaston.

1. Introduction

Mixing processes can be realized in mechanical, static, pneumatic, hydraulic and magnetic mixers. However, the most commonly used are mechanical mixers, where the mixing process initiated by rotating impellers takes place. Because of the large number of commercially available impellers, there are many structural constructions of mixer. Nevertheless, their effectiveness depends on the process parameters and the properties of the stirred medium. Therefore, despite the fact that the mixing process was often tested by different researchers, both theoretically and experimentally, there is still a need to conduct research aiming at better understanding of the hydrodynamics occurring inside the mixing tank and, consequently, optimizing the mixing process.

In this study, experimental results of the velocity field measurements of a Newtonian fluid in a mixing tank equipped with the Prochem Maxflo T (PMT) type impeller will be presented. Extensive research for this type of the impeller was carried out by McFarlane and Nienow [1–3]. The authors presented results for the hydrodynamics and power consumption in two-phase gas-liquid bioreactors. However, in those cases the impeller had only five blades. Research for stirred tank equipped with a six blade PMT impeller was carried out by Schell et al [4], Jaworski and Nienow [5] and Jaworski et al [6]. Schell et al [4], similarly to McFarlane and Nienow [1–3], conducted studies in bioreactors. They investigated the effect of the PMT impeller on the oxygen dispersion during growth of microorganisms in the production of cellulase. Jaworski and Nienow [5] and Jaworski et al [6] have studied hydrodynamics in a mixing tank equipped with one of the two impellers: PMT or Chemineer HE3 for Newtonian and non-Newtonian shear-thinning liquids. To determine the velocity field of the liquid they used the Laser Doppler Anemometry (LDA) technique. In none of the analyzed publications presenting results for the PMT type impeller has the Particle Image Velocimetry (PIV) technique to determine the fluid velocity field yet been used.

The experimental study presented in this paper was carried out using the PIV technique. The measurement results are shown in the form of the ensemble average velocity vectors and maps in a vertical plane located at the angle of 45° between the baffles and in horizontal planes located at twelve different axial positions in the range of $z = -80 \div 70$ [mm], where the value $z = 0$ [mm] corresponds to the center of the impeller. Then, the velocity vectors obtained from the PIV measurements were compared with LDA results available in the literature [5] for the same mixing tank. The values of the axial and radial circulation flow number, K_C , were calculated.

2. Experimental

2.1. Measurement technique

Particle Image Velocimetry is an optical, non-invasive technique which is used for velocity flow field measurements. One of the requirements for application of the PIV technique is adding the tracer particles to the volume of stirred liquid. The tracer particles are assumed to faithfully follow the flow dynamics and to not disturb it. Seeding particles cannot also react with a mixed medium. As the tracer particles, for example, glass spheres,

polystyrene particles, aluminum, titanium dioxide, fluorescent polymer particles, and even oil or gas bubbles can be used. During the measurements the laser light is scattered on the tracer particles. Next, the scattered light is captured by the CCD Camera, which records two images, I_1 and I_2 , in the known interval of time, Δt .

In the next step the captured images are divided into small sections called interrogation areas (IA). The cross-correlation operation (1) of corresponding sections of two successive image frames allows determination of the displacement vector of tracer particles, $\Delta\bar{X}$, and the velocity vector, \bar{V} , (2).

$$C(s) = \iint_{IA} I_1(\bar{X}) \cdot I_2(\bar{X} - s) d\bar{X} \quad (1)$$

$$\bar{V} = \frac{\Delta\bar{X}}{\Delta t} \quad (2)$$

The basic characteristic that distinguishes PIV from LDA is a different way of illuminating the system by the laser light. In the LDA two beams of laser light go through the test system. The laser light beams cross each other and form a single point of measurement. In the PIV laser light falls on the test system as a planar light sheet. The use of laser light sheet enables to collect the data in a multi-point mode, which also allows for immediate access to information about the generated velocity field and its evaluation. However, a basic requirement for application of the LDA or PIV technique to the flow field analysis is the use of optically transparent walls for the apparatus and translucent fluids.

The main components of the PIV system are: laser, camera, synchronizer and computer with software, which are shown in Fig. 1.

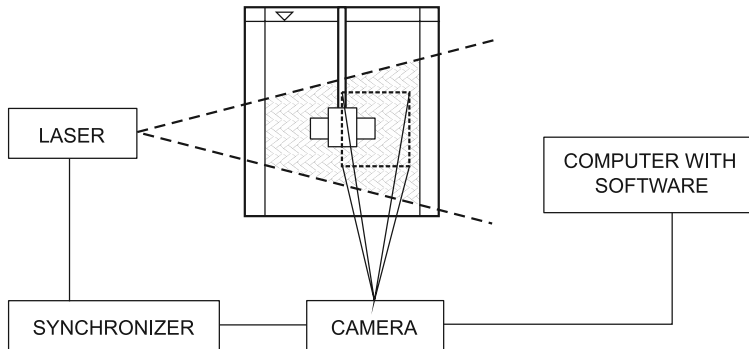

Fig. 1. Components of the PIV system

In the present study the measuring equipment was equipped with the Litron Lasers Nano L 50-100 PIV Pulsed Nd: YAG laser with a wavelength of 532 nm and the TSI PowerView™ Plus 4MPcamera. Silver coated hollow glass spheres with an average diameter of 10 [μm] from Dantec company were used as the tracer particles. Image analysis was performed using the TSI INSIGHT™ 4G software.

2.2. The studied system

Experimental studies were carried out for the same system as in the literature [5]. It was the flat-bottomed stirred tank of a diameter equal to $T = 0.222$ [m]. The tank was equipped with four flat, standard baffles and the PMT type impeller of a diameter equal to $D = 0.078$ [m]. The center of the impeller was in a distance of 0.1 [m] from the tank bottom. The tank was filled up with a Newtonian liquid – distilled water ($\rho = 998.2$ [kg·m³], $\mu = 1.003 \cdot 10^{-3}$ [Pas]), to the height $H = T$. A scheme of the studied system is shown in Figure 2.

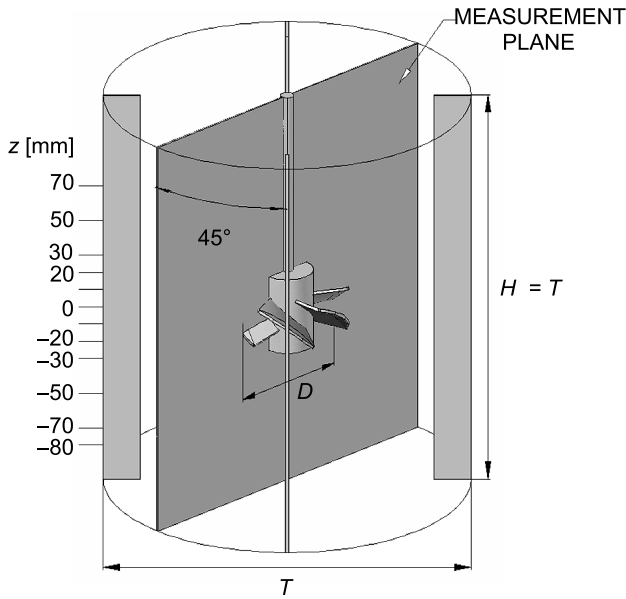

Fig. 2. Scheme of the mixing tank

Velocity measurements were taken in a vertical plane located at an angle of 45° between the baffles and in horizontal planes located at twelve different axial positions, every 10 [mm] in the range of $z = -80 \div 70$ [mm], with the value $z = 0$ [mm] being the axial coordinate of the center of the impeller. The impeller rotated at a constant frequency of $N = 4.1$ [s⁻¹]. The calculated value of the impeller tip(peripheral) velocity ($= \pi DN$) was $v_{\text{TIP}} = 1$ [m·s⁻¹]. The water flow was turbulent and the value of the Reynolds number for mixing was $Re \cong 24\,800$ [-].

3. Results and discussion

The results of PIV measurements are presented graphically in the form of mean velocity vectors and maps. The ensemble average of the components of velocity were obtained by averaging the local instantaneous values read for different angular positions of the impeller blades against the measurement plane.

In the case of axisymmetric flows, based on the velocity in the vertical plane, the circulation flow number, K_C , can be calculated from equation:

$$K_C = \frac{Q_C}{ND^3} \quad (3)$$

In Eq.(3), the circulation flow rate, Q_C , is the maximum value of the volumetric primary flow rate occurring in a stirred tank, Eq. (4), where the axial and radial volumetric flow rates, Q_j ($j = r, z$), are described by Eq. (5a, b) with the assumption of the angular symmetry of the flow. The volumetric flow rates, Q_j , were computed at constant distances of either $z_0 = 56$ [mm] from the tank bottom or $r_0 = 80$ [mm] from the tank axis for the axial and radial volumetric flow rates, respectively.

$$Q_C = \max\{Q_j\} \quad (4)$$

$$Q_z(z_0) = 2\pi \int_{r_1}^{r_2} r(\bar{v}_z)z_0 dr \quad (5a)$$

$$Q_r(r_0) = 2\pi r_0 \int_{z_1}^{z_2} (\bar{v}_r)r_0 dz \quad (5b)$$

The value of the circulation flow number calculated from PIV measurements, Eq. (3), was $K_{C,PIV} = 1.5$. The corresponding value of K_C obtained from LDA measurements was equal to $K_{C,LDA} = 1.55$ [5] and was similar to that obtained from PIV.

3.1. Vectors and profiles of mean velocity

In Figure 3a, the radial and axial mean velocity components obtained from PIV measurements are graphically presented as vectors of $v_{rz} \left(= \sqrt{v_r^2 + v_z^2} \right)$, in a mid-plane between two neighbouring baffles. Based on the directions of velocity vectors it was found that one primary circulation loop, encompassing the rotating impeller, was observed in the flow field. There were also two secondary circulation loops, induced by motion of the fluid in a radial-axial plane. The primary circulation loop spreads from the center of the impeller to the bottom of the tank occupying a major part of the tank. It follows that the PMT type impeller was pumped liquid mainly towards the bottom of the tank and generated typically axial circulation of the liquid. The secondary circulation loops were formed above the impeller, at the free surface of the stirred liquid and underneath the impeller hub. The latter one had a conical shape. The secondary circulation loops were smaller than the primary one and were characterized by a lower intensity.

In Figure 3b, vectors of mean velocity for the analogous system, obtained from the LDA measurements [5] are presented for comparison. Comparing the vectors of mean velocity which are presented in Figs. 3a, 3b it was found that both methods of flow measurement – PIV and LDA, gave qualitatively similar results – the liquid was pumped down and created a typical axial-radial circulation and one primary and two secondary circulation loops were identified. The difference that has been observed, refers to the height of the primary circulation loop. In the case of PIV measurements this loop reached the bottom of the

tank and ended about 50 [mm] above the center of the impeller, while in the case of LDA measurements it also reached the bottom of the tank, but ended about 60 [mm] above the center of the impeller.

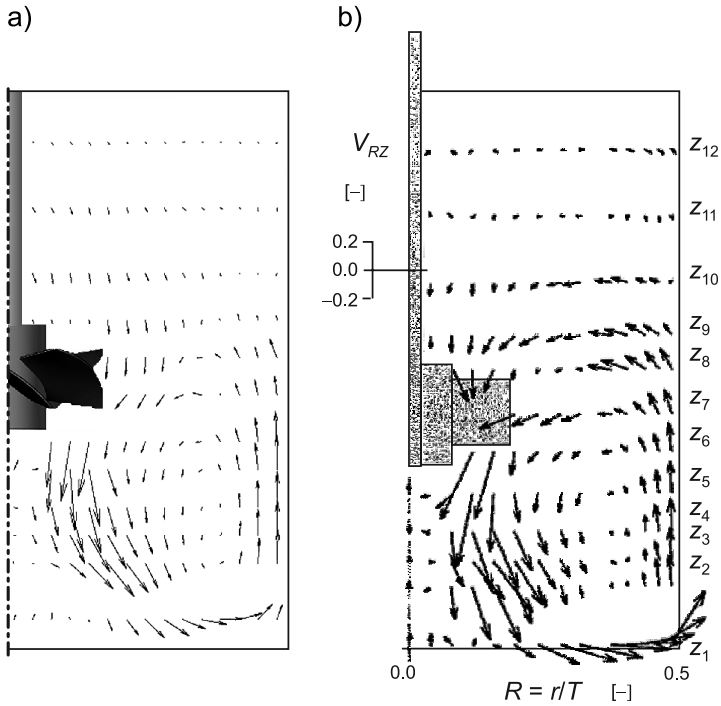

Fig. 3. Vectors of mean velocity in a mid-plane between two neighbouring baffles: a) PIV measurement, b) LDA measurement [5]

Vectors of the radial-tangential mean velocity obtained from PIV measurements in horizontal planes located at twelve different axial positions in the stirred tank are shown in Fig. 4. Each part of the figure shows 1/4 of the cross-sections between baffles, which are located at the edges of the sections. While analyzing the velocity vectors in the cross-sections, the intensity of the radial circulation of the stirred liquid can also be observed. As it can be seen, radial circulation of the liquid just above the impeller and at a distance of 10 [mm] below the center of the impeller is very poor. Fluid is here axially drawn to the impeller and the velocity vectors are directed from the walls to the axis of the tank. At height $z = -20$ and -30 [mm] a strong circular motion of the liquid was observed, however it was located under the impeller blades only. Closer to the bottom of the tank, the radial flow was increasing. At the distances of $z = -70 \div -80$ [mm] the fluid was pumped primarily in the radial direction towards the wall. Analyzing the velocity vectors shown in Fig. 3 and 4 it can be concluded that the PMT type impeller generated in the impeller discharge stream an intensive axial flow and poor radial circulation. Good radial circulation occurs at the bottom of the vessel only and it is caused by impingement of the liquid on the bottom of the tank.

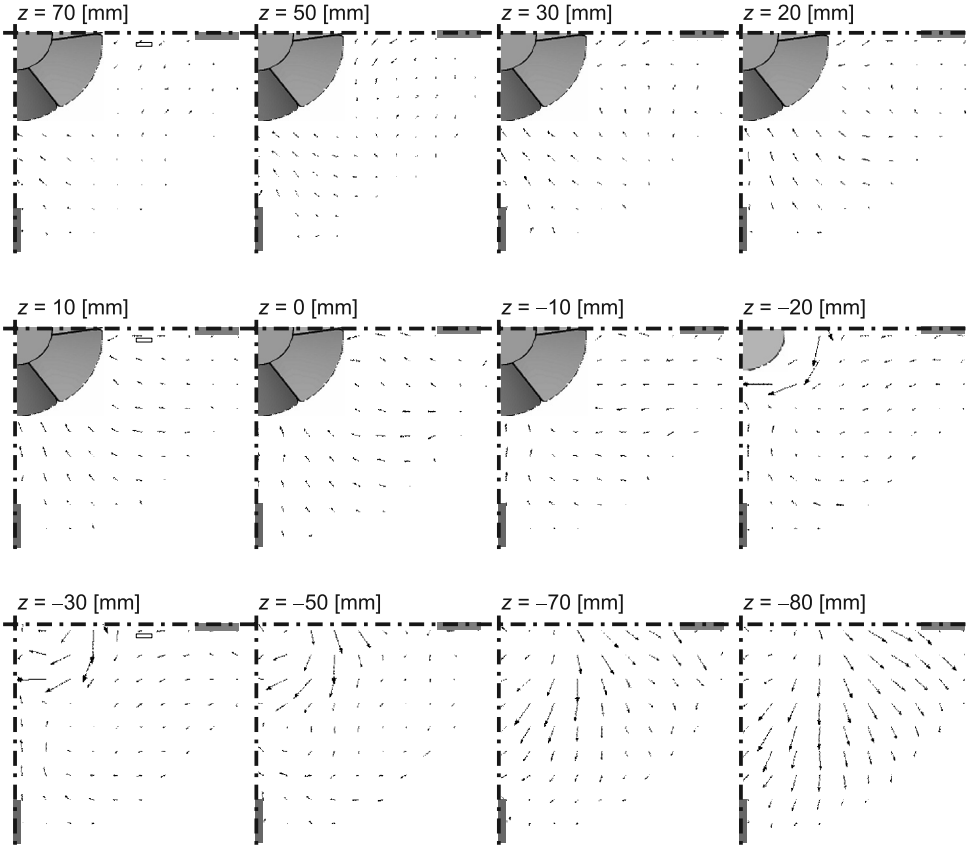

Fig. 4. Vectors of mean velocity in horizontal planes located at twelve different axial positions $z = -80 \div 70$ [mm]

Based on the axial velocity distribution in the vertical mid-plane between two neighbouring baffles, the profiles of the dimensionless axial velocity component were plotted (Fig. 5).

The axial velocities were standardized by the peripheral velocity of the impeller, v_{TIP} . Subsequently, the values of the mean square deviation between the axial velocity component obtained from the PIV measurements, $\bar{V}_{Z,PIV}$, and those from the literature [6] data for the LDA measurements, $\bar{V}_{Z,LDA}$, were calculated from equation (6):

$$\sigma = \sqrt{\frac{\sum (\bar{V}_{Z,PIV,i} - \bar{V}_{Z,LDA,i})^2}{(n-1)}} \cdot 100\% \quad (i=1 \dots n) \quad (6)$$

where n number of measurement points equal to $n = 189$. The value of the mean square deviation is 4.2%, which indicates a good agreement between the PIV and LDA results.

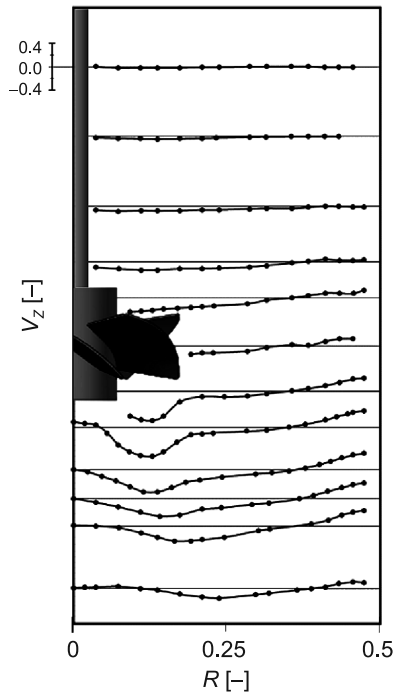

Fig. 5. Profiles of the dimensionless axial velocity component in vertical mid-plane between two neighbouring baffles

3.2. Maps of mean velocity

Maps of the mean velocity in a vertical plane located at an angle of 45° between the baffles (Fig. 6a) and in a horizontal planes located at twelve different axial positions, z , (Fig. 6b), obtained from PIV measurements, are presented in Figure 5. The average velocity took values in the range from 0 to 0.5 [m/s], reaching a maximum value just below the agitator blades, where the primary circulation started form. The maximum average velocity value was about two times smaller than the v_{TIP} . Above the impeller the fluid velocity was significantly lower in the entire cross section of the mixing tank. In addition, at the heights from $z = 70$ to -10 [mm] the velocity distribution in the cross section was similar, therefore for this height range only one map of the mean velocity is presented, for $z = -10$ [mm]. At the heights $z = -20 \div -50$ [mm] the mean velocity of the stirred liquid rapidly decreased with the flow moved away from the axis of the tank. At the bottom of the vessel the maximum fluid velocity was close to $v = 0.25$ [m/s].

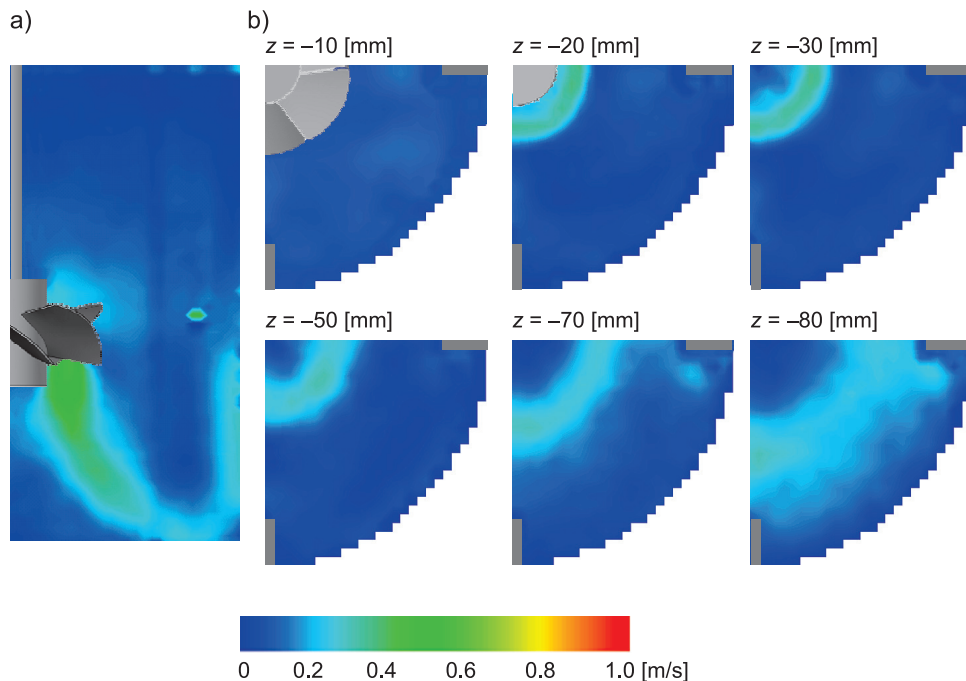

Fig. 6. Maps of the mean velocity: a) vertical mid-plane between two neighbouring baffles, b) horizontal planes at heights $z = -80 \div 70$ [mm]

4. Conclusions

The paper presented the measurement results of the velocity field of a Newtonian fluid in a mixing tank equipped with a PMT type impeller. The measurements were performed using the PIV technique. The results are presented in the form of vectors, profiles and maps of the mean velocity. The velocity vectors in the mid-plane at the angle of 45° between the baffles were compared to literature data obtained from LDA measurements for the same system, noting their good qualitative compatibility. In the flow field one primary and two secondary circulation loops were observed. Analysis of velocity vectors and map shows that the PMT type impeller generated a typical axial-radial circulation of the fluid in the tank. The profiles of the dimensionless axial velocity component were plotted and compared with the published LDA results. The calculated value of the mean square deviation between the PIV and LDA measurements was equal to 4.2%. Moreover, the value of the circulation flow number, K_C , was calculated and compared with the published corresponding number calculated from results of LDA measurements.

The obtained results constitute an experimental data bank, which can be further used to verify the data obtained from CFD numerical simulations.

A.D. would like to thank for the financial support from the West Pomeranian University of Technology in Szczecin and also for the valuable advice of Mr. John Ramsay regarding the PIV measurement technique.

References

- [1] McFarlane C.M., Nienow A.W., *Studies of High Solidity Ratio Hydrofoil Impellers for Aerated Bioreactors. 2. Air-Water Studies*, Biotechnology Progress, vol. 11, 1995, 608-618.
- [2] McFarlane C.M., Nienow A.W., *Studies of High Solidity Ratio Hydrofoil Impellers for Aerated Bioreactors. 3. Fluids of Enhanced Viscosity and Exhibiting Coalescence Repression*, Biotechnology Progress, vol. 12, 1996, 1-8.
- [3] McFarlane C.M., Nienow A.W., *Studies of High Solidity Ratio Hydrofoil Impellers for Aerated Bioreactors. 4. Comparison of Impeller*, Biotechnology Progress, vol. 12, 1996, 9-15.
- [4] Schell D.J., Farmer J., Hamilton J., Lyons B., McMillan J.D., Sáez J.C., Tholudur A., *Influence of Operating Conditions and Vessel Size on Oxygen Transfer During Cellulase Production*, Applied Biochemistry and Biotechnology, 91-93, 2001, 627-642.
- [5] Jaworski Z., Nienow A.W., *LDA measurements of flow fields with hydrofoil impellers in fluids with different rheological properties*, IChemE Symp. Series, No. 136, 1994, 105-112.
- [6] Jaworski Z., Nienow A.W., Dyster K.N., *An LDA study of the turbulent flow field in a baffled vessel agitated by an axial, down-pumping hydrofoil impeller*, The Canadian Journal of Chemical Engineering, vol. 74, 1996, 3-15.