

Exergy and energy analysis of a load regulation method of CVO of air separation unit

Tong, Lige; Zhang, Aijing; Li, Yongliang; Yao, Li; Wang, Li; Li, Huazhi; Li, Libing; Ding, Yulong

DOI:

[10.1016/j.applthermaleng.2015.01.074](https://doi.org/10.1016/j.applthermaleng.2015.01.074)

License:

Other (please specify with Rights Statement)

Document Version

Peer reviewed version

Citation for published version (Harvard):

Tong, L, Zhang, A, Li, Y, Yao, L, Wang, L, Li, H, Li, L & Ding, Y 2015, 'Exergy and energy analysis of a load regulation method of CVO of air separation unit', *Applied Thermal Engineering*, vol. 80, pp. 413-423. <https://doi.org/10.1016/j.applthermaleng.2015.01.074>

[Link to publication on Research at Birmingham portal](#)

Publisher Rights Statement:

NOTICE: this is the author's version of a work that was accepted for publication. Changes resulting from the publishing process, such as peer review, editing, corrections, structural formatting, and other quality control mechanisms may not be reflected in this document. Changes may have been made to this work since it was submitted for publication. A definitive version was subsequently published as L. Tong, A. Zhang, Y. Li, L. Yao, L. Wang, H. Li, L. Li, Y. Ding, Exergy and energy analysis of a load regulation method of CVO of air separation unit, *Applied Thermal Engineering* (2015), doi: 10.1016/j.applthermaleng.2015.01.074.

General rights

Unless a licence is specified above, all rights (including copyright and moral rights) in this document are retained by the authors and/or the copyright holders. The express permission of the copyright holder must be obtained for any use of this material other than for purposes permitted by law.

- Users may freely distribute the URL that is used to identify this publication.
- Users may download and/or print one copy of the publication from the University of Birmingham research portal for the purpose of private study or non-commercial research.
- User may use extracts from the document in line with the concept of 'fair dealing' under the Copyright, Designs and Patents Act 1988 (?)
- Users may not further distribute the material nor use it for the purposes of commercial gain.

Where a licence is displayed above, please note the terms and conditions of the licence govern your use of this document.

When citing, please reference the published version.

Take down policy

While the University of Birmingham exercises care and attention in making items available there are rare occasions when an item has been uploaded in error or has been deemed to be commercially or otherwise sensitive.

If you believe that this is the case for this document, please contact UBIRA@lists.bham.ac.uk providing details and we will remove access to the work immediately and investigate.

Accepted Manuscript

Exergy and energy analysis of a load regulation method of CVO of air separation unit

Lige Tong, Ph.D, Associate Professor, Aijing Zhang, Yongliang Li, Ph.D, Lecture, Li Yao, Ph.D, Professor, Li Wang, Professor, Huazhi Li, Professor, Libing Li, Professor, Yulong Ding, Ph.D, Professor

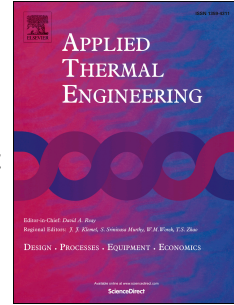

PII: S1359-4311(15)00103-9

DOI: [10.1016/j.applthermaleng.2015.01.074](https://doi.org/10.1016/j.applthermaleng.2015.01.074)

Reference: ATE 6345

To appear in: *Applied Thermal Engineering*

Received Date: 20 October 2014

Accepted Date: 28 January 2015

Please cite this article as: L. Tong, A. Zhang, Y. Li, L. Yao, L. Wang, H. Li, L. Li, Y. Ding, Exergy and energy analysis of a load regulation method of CVO of air separation unit, *Applied Thermal Engineering* (2015), doi: 10.1016/j.applthermaleng.2015.01.074.

This is a PDF file of an unedited manuscript that has been accepted for publication. As a service to our customers we are providing this early version of the manuscript. The manuscript will undergo copyediting, typesetting, and review of the resulting proof before it is published in its final form. Please note that during the production process errors may be discovered which could affect the content, and all legal disclaimers that apply to the journal pertain.

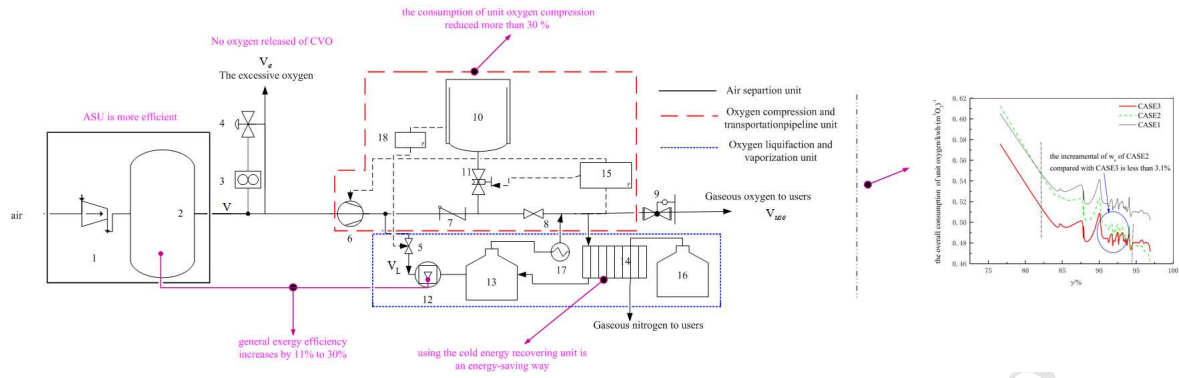

ACCEPTED MANUSCRIPT

Exergy and energy analysis of a load regulation method of CVO of air separation unit

Lige Tong^{1,2,3} Aijing Zhang¹ Yongliang Li² Li Yao⁴ Li Wang^{1,3} Huazhi Li¹
Libing Li⁴ Yulong Ding²

1) School of Mechanical Engineering, University of Science & Technology
Beijing, Beijing, 100083, China

2) School of Chemical Engineering, University of Birmingham, Birmingham,
B152TT, United Kingdom

3) Beijing Engineering Research Center for Energy Saving and Environmental
Protection, University of Science and Technology Beijing, Beijing 100083,
China

4) Tangshan Tangsteel Gas Co. Ltd., Tangshan, 063016, China

***Corresponding author:** Lige Tong, Associate Professor, Ph.D, School of
Mechanical Engineering, University of Science & Technology Beijing, Beijing,
100083, China. Email: tonglige@me.ustb.edu.cn, Tel: +86-10-62334971, Fax:
+86-10-62332741.

Aijing Zhang

School of Mechanical Engineering, University of Science & Technology Beijing,
Beijing, 100083, China. Email: zhangaijing02@sina.com, Tel: +86-10-62332741,
Fax: +86-10-62332741.

Yongliang Li

22 Lecture, Ph.D, School of Chemical Engineering, University of Birmingham,
23 Birmingham, B152TT, United Kingdom. Email: Y.Li.1@bham.ac.uk, Tel.: 44
24 (0)121-4145276, Fax: 44 (0)121-4145377.

25 **Li Yao**

26 Professor, Ph.D, Tangshan Tang steel Gas Co. Ltd., Tangshan, 063016, China.
27 Email: yaoli@tsggs.com. Tel: +86-10-62332741, Fax: +86-10-62332741.

28 **Li Wang**

29 Professor, School of Mechanical Engineering, University of Science &
30 Technology Beijing, No.30 Xueyuan Road, Haidian District, Beijing, China.
31 100083. liwang@me.ustb.edu.cn. Tel: +86-10-62334425, Fax:
32 +86-10-62329145.

33 **Huazhi Li**

34 Professor, School of Mechanical Engineering, University of Science &
35 Technology Beijing, Beijing, 100083, China. Email: 15h0z8@126.com.

36 **Libing Li**

37 Professor, Tangshan Tang steel Gas Co. Ltd., Tangshan, 063016, China. Email:
38 lilibing@tsggs.com.

39 **Yulong Ding**

40 Professor, Ph.D, School of Chemical Engineering, University of Birmingham,
41 Birmingham, B152TT, United Kingdom. Email: Y.Ding@bham.ac.uk. Tel
42 +441214145279, Fax: +441214145279.

Exergy and energy analysis of a load regulation method of CVO of air separation unit

Lige Tong^{1,2,3} Aijing Zhang¹ Yongliang Li² Li Yao⁴ Li Wang^{1,3} Huazhi Li¹
Libing Li⁴ Yulong Ding²

1) School of Mechanical Engineering, University of Science & Technology
Beijing, Beijing, 100083, China

2) School of Chemical Engineering, University of Birmingham, Birmingham,
B152TT, United Kingdom

3) Beijing Engineering Research Center for Energy Saving and Environmental
Protection, University of Science and Technology Beijing, Beijing 100083,
China

4) Tangshan Tangsteel Gas Co. Ltd., Tangshan, 063016, China

Abstract

Generally in the Chinese iron and steel industry, the electricity consumption of cryogenic air separation unit (ASU) is about 14 % of the overall electricity use. To reduce the electricity consumption, the combined variable oxygen (CVO) supply method for ASU is proposed. The exergy calculation program for ASU was developed and the detailed analysis of CVO method was performed. The results show that the general exergy efficiency (GEE) of ASU combined with a liquefaction unit is increased by 11 % to 31 %. The consumption of unit oxygen, the total electricity consumption and the overall consumption of unit oxygen (OCUO) was compared. The OCUO is a suitable method to evaluate the energy-saving potential of CVO. Compared with the load regulation method of Automatic Load Control (ALC), the

66 OCUO and the unit consumption of compression of CVO reduced more than 4.47 %
67 and 30 %, respectively. It means that CO₂ emission of every reduction 1 % of gaseous
68 oxygen release in a year in Chinese iron and steel industry will contribute
69 approximately 0.75 % to the 2020s CO₂ emission reduction target of China.

70 **Key words: air separation unit; variable load; exergy analysis; energy**
71 **consumption; CO₂ emission**

72 1 Introduction

73 Chinese iron and steel industry has become the largest crude steel producer in the
74 world since 1996^[1], the iron and steel industry requires quantities of high-purity
75 industrial gas which would be 100 ~ 140 m³ of O₂ per ton of steel, 100 ~ 140 m³ of N₂
76 per of ton steel and 3 ~ 4 m³ of Ar per ton of steel. For the process of direct reduction
77 iron making, the oxygen demand should be 550 to 650 m³ per ton of steel ^[2].
78 According to a report by World Steel Association in 2013, 779.04 million ton of crude
79 steel in mainland China ^[3] accounts for 49.23 % of the total production of the whole
80 world. It means that from 7.79 to 10.91 billion m³ of O₂ is consumed by the Chinese
81 iron and steel industries. The electricity cost of cryogenic air separation unit (ASU) is
82 more than 10 billion US dollars in 2010^[4]. The electricity consumption of the iron and
83 steel industry is about 15.2 % of the total electricity consumption in China in 2007 ^[5],
84 in which the electricity consumption of ASU and the oxygen compression and
85 transportation pipeline (OCTP) unit is about 14 % of the total electricity consumption
86 of iron and steel industries in China^[6]. The data is steady in recent years. The net

87 demand for electricity of the industrial gases industry is 31,460 million kilowatt hours
88 (kWh) in the USA in 1998^[7]. The demand increased to 39,431 million kWh in 2010,
89 which accounts for 2.8 % of the total electricity purchased by the manufacturing
90 industry and is an increase of 25.4 % compared with the amount in 1998^[8]. Due to the
91 high electricity consumption of industrial gases industry, it's meaningful to reduce its
92 electricity consumption by researching new load regulation method of ASU.

93 Most of the iron and steel industries in China have their own gas production
94 plant in which multiple ASUs operate together to supply whole customers of
95 industry or other customers rather than supply product via pipeline to multiple
96 customers^[9]. The gaseous production from ASU is compressed into the OCTP unit to
97 transport to the customers. With large-scale ASU as well as large-scale blast furnaces
98 and converters, the contradiction between supply and demand of gaseous oxygen (GO)
99 has become increasingly prominent because oxygen demand in fluctuation, which
100 causes the oxygen release ratio (ORR, defined as the proportion of the amount of
101 released oxygen product to the oxygen production capacity of ASU) of China to
102 increase. To decrease the ORR in China, three measures were taken. The first is
103 automatic load control (ALC) technique. The second is the variable oxygen (VAROX)
104 supply technique made by the Linde Group^[10]. The third is using the liquefaction unit
105 (LU) to liquefy excessive gaseous oxygen (EGO) into a liquid product tank^[11~13].
106 However, the load transition speed of ALC is slow^[14, 15] and the ALC should be
107 configured for each ASU. Moreover, load regulation of ALC and VAROX would

108 change the distillation conditions of ASU^[16]. In 2010, the average ORR in Chinese
109 large-scale ASUs is more than 3.0 %^[11], with an example of Hangzhou Hangyang Co.
110 Ltd which uses ALC as its ORR is 3.75 %^[17]. The liquefaction capacity is also
111 limited by the capacity of the liquid product tank. The other countries' gas production
112 plant also consumed large amount of electricity purchased by the manufacturing
113 industry. Therefore, researching new operation strategies to reduce the ORR will
114 result in substantial economic benefits.

115 For variable load regulation (VLR) of ASU, the load regulation method to
116 change the distillation operation conditions such as ALC is called the internal VLR
117 method. The regulation method to change product flow and pressure in OCTP unit is
118 called the external VLR method. The variable load regulation method combining
119 ALC and LU is called Combine Variable Oxygen (CVO) supply method. This novel
120 method is as follows. Variable load operation of ASU uses ALC, combining
121 liquefaction unit in which the EGO is liquefied by LU or the cold energy recovery
122 (CER) unit using cold from liquid oxygen (LO) or liquid nitrogen (LN) from a storage
123 tank. The exergy analysis of ASU and liquefaction process of CVO is carried out. The
124 electricity consumption of ASU with CVO is compared and evaluated with the
125 electricity consumption of ASU with ALC. It provides guidance for reducing of the
126 electricity consumption of ASU in the next decade.

127 2 The proposed variable load regulation method

128 2.1 ALC operation method

129 Cryogenic air separation is currently the most efficient technology for producing
130 large quantities of oxygen, nitrogen, and argon as gaseous or liquid products^[18]. The
131 customer's demand always has fluctuations. Therefore, ASU must rapidly change the
132 product to meet the customers' demand. Otherwise, the EGO has to be released.
133 Today, the EGO is stored into the OCTP unit including oxygen compressor (OC),
134 oxygen pipeline and the storage tank of gaseous oxygen (GO) or LO, whose pressure
135 is maintained at 2.5 to 3.0 MPa. However, the lowest required pressure of GO in
136 steelmaking process is about 1.2 MPa. The important aim to increase the pressure of
137 the oxygen pipeline is for more storage of GO for reducing ORR and balancing
138 between the production and the demand easily. When the demand is larger than the
139 production, the GO in the sphere tank is quickly sent to the customers. Emergency
140 vents must be opened to release GO when the pressure exceeds the upper pressure
141 limits. The electricity consumption of OC could be reduced if we had a quickly load
142 regulation method of ASU.

143 There are two reasons which cause the gaseous product to release. First, it is far
144 more difficult for ASU to rapidly respond to the changing product to meet the
145 customer demand at the transition speed. The transition speed of ALC is about
146 4-5minutes per 1 % of rated load. The shorter the transition time of load change, the
147 lesser the energy consumption^[15]. Besides, in many manufacturing processes, gaseous

148 product demand is not fixed but intermittent, especially the converter smelting process
149 where oxygen demand lasts 15 minutes while the whole cycle lasts 30 minutes.
150 Secondly, the down-regulation of the load according to the demand of one production
151 may lead to insufficient supply of another gaseous product, because the large-scale
152 ASU is a multi-product production equipment in which the production and purity of
153 one product is related to that of the other products. Moreover, the ASU would be
154 more efficient while it operates under rated load as described by Li^[19].

155 Therefore, load regulation of ASU is necessary not only to take the distillation
156 operation stability of ASU and make the balance between the production and demand
157 for each product of ASU, but also to match the customer demand with the transition
158 speed of load regulation of ASU. With the development of the production technology
159 of iron and steel industry, the ASU has to run under a load condition meeting the
160 increasing demand for GN and argon (Ar). At such load condition, more GO could
161 not be consumed leading to more EGO being released. With oxygen supply system as
162 an example, the CVO is analyzed.

163 2.2 CVO regulation method

164 Fig.1 shows the principle of oxygen system of ASU with CVO, which consists of
165 ASU, OCTP unit, and oxygen liquefaction and vaporization unit. The product load
166 rate γ is defined as Eq. (1). The γ means the load rate of oxygen production in this
167 paper unless specified otherwise.

$$168 \quad \gamma = \frac{V}{V_n} \times 100\% \quad (1)$$

169 The CVO system has two operational modes to meet the customer's demand:

170 (1) The internal VLP method for ASU: the γ is increased closely to 100%
 171 (described as section 4.1). Then, the ASU operates steadily at some constant γ , until a
 172 substantial reduction of the gaseous oxygen demand lasts for more than 4 hours (such
 173 as the annual repair of the blast furnace).

174 (2) The external VLP method for OCTP unit and oxygen liquefaction and
 175 vaporization unit: The discharge pressure of valve 9 (see in Fig.1) is set as 1.5 MPa
 176 and the average pressure of OCTP unit is maintained around 1.5 MPa. At trough
 177 hours when the pressure of OCTP unit is greater than $(1.5+\Delta p)$ MPa, the EGO is
 178 pressurized first by an oxygen compressor and then is liquefied by the LU 12 and
 179 CER unit 14 to store in the liquid tank 13. At peak hours, the oxygen demand
 180 increases while the production of ASU is not enough, the GO is taken from sphere
 181 tank 10 or LO evaporator 14. The principle of operation of CER unit is making the
 182 liquid product exchange heat with gaseous product so that the cold energy in the
 183 liquid product could be recovered. The Δp is influenced by the capacity of OCTP unit.
 184 The volume of the EGO to be liquefied is shown as Eq. (2).

$$185 \quad V_l = V_e = V - V_{use} \quad (2)$$

186 In the circumstances described in (1), the down-regulation of load is carried out
 187 in ASU by ALC, and the EGO is liquefied into liquid storage tank by oxygen
 188 liquefaction and vaporization unit consisting of LU, CER, liquid tank and LO
 189 evaporator.

190 With the increase in γ of ASU, the amount of GO product would also raise so
191 that the instantaneous larger GO demand in steelmaking process could be met.
192 Besides, the EGO could be liquefied into a liquid tank by the oxygen liquefaction and
193 vaporization unit, stopping oxygen from being released; When the GO demand
194 becomes larger, the LO could be evaporated to users. Thus, with increased production
195 and storage of GO, the contradiction between continuous production of ASU and
196 fluctuant demand of users can be solved.

197 The LU of CVO, shown as Fig.2 (a), is used to liquefy the EGO. The
198 low-pressure nitrogen from ASU, mixed with the nitrogen out of heat exchanger HE5,
199 is compressed by a nitrogen compressor. Then part of the low-pressure nitrogen goes
200 through the expander ET2 to a low pressure and produces cold energy for HE5. The
201 other part of the low-pressure nitrogen undergoes two stages of booster compressors
202 BC and then is cooled by the water coolers. The nitrogen is cooled by heat exchanger
203 HE5 and HE6. Most of the nitrogen is withdrawn to expander ET3 to a specific
204 temperature; the other part of the nitrogen is cooled by heat exchanger HE7 to be LN.
205 The feed oxygen gas undergoes the heat exchangers HE5, HE6 and HE7 to be
206 liquefied as LO.

207 The CER unit including liquid product storage tank, plate heat exchanger (HE8)
208 and several throttle valves, shown as Fig.2 (b), was similar to the device in ref. 20 and
209 ref.21. The GO from OCTP system undergoes the heat exchanger E8 and then is

210 liquefied as LO, while the LO from liquid tank is vaporized in HE8 and then is sent to
211 OCTP system.

212 Switching time from full-liquid nitrogen conditions to full-liquid oxygen
213 conditions is about 10 minutes. Under full liquid oxygen conditions, the maximum
214 oxygen production liquefied from gaseous oxygen is $8,750 \text{ m}^3 \cdot \text{h}^{-1}$. The liquefaction
215 capacity of the CER unit is $5000 \text{ m}^3 \cdot \text{h}^{-1}$ and its start-up time is 4 min. Therefore, the
216 oxygen supply can be reduced by $13,750 \text{ m}^3 \cdot \text{h}^{-1}$ within 10 minutes. For example, if
217 applying the CVO, the transition speeds of eight ASUs with product capacity of
218 $102,000 \text{ m}^3 \cdot \text{h}^{-1}$ would be 1.35 % of rated load per minute and is twice the transition
219 speed of the ASU with ALC. For example, the pressure of OCTP unit at different time
220 is shown in Fig.3. Fig. 3 shows the fluctuation of the pipeline pressure, which can
221 reflect the change of gaseous oxygen demand. Therefore, the shorter the transition
222 time of load change, the quicker the users' demand is met.

223 The following summarizes three advantages of the CVO regulation: 1) The ASU
224 is running closely to rated load (detailed analysis shown in section 4.3), thus the
225 efficiency of the ASU is higher. 2) The pressure of OCTP unit runs at lower level to
226 reduce the energy consumption of compression. 3) The EGO is liquefied by the LU
227 and CER unit so that the ORR is lower and the LO production is higher. Moreover,
228 the transition speed of CVO is faster than of ALC described as in section 2.2.
229 However, the total energy consumption may increase because the LU would consume
230 a lot of electricity.

231 3 Exergy analysis of ASU with CVO regulation method

232 Based on the exergy analysis, a 40,000 m³·h⁻¹ of external ASU with CVO
 233 regulation method and the liquefaction system have been evaluated and the exergy
 234 efficiency of single ASU is compared with the ASU combing LU .

235 3.1 A TYPICAL EXTERNAL COMPRESSED CRYOGENIC AIR SEPARATION PROCESS

236 The external ASU studied in this paper uses the principle of two-column
 237 separation based on a low- and high-pressure distillation column, shown as Fig. 4^[22].
 238 Air is firstly compressed in the main air compressor (AC), and then purified to
 239 remove the primary impurities such as H₂O, CO₂, and C₂H₂ via molecular sieves
 240 absorbers (MS). Part of the pure air is cooled in the main heat exchanger (MHE1) to
 241 saturation temperature and enters the lower column (C1). The others enter a
 242 turbocharger; then the air is cooled in HE1 to 164 K and is expanded in an expansion
 243 turbine (ET); subsequently, the air enters the upper column (C2). The crude argon
 244 column (C701, C702 and C703) is configured in the cold box. The product index is
 245 shown in Table 1.

246 3.2 The exergy efficiency

247 According to Chinese GB/T 14909-2005, named the technical guides for exergy
 248 analysis in energy system, the exergy and the general exergy efficiency ^[23] is
 249 calculated by Eq. (3) and Eq. (4), respectively.

$$250 \quad E_m(T, p) = \sum x_i E_{m,i}(T, p) + RT_0 \sum x_i \ln \frac{f_i}{f_{i0}} + (1 - \frac{T_0}{T}) \Delta_{mix} H_m \quad (3)$$

$$\eta_{\text{gen}} = \frac{E_{\text{out}}}{E_{\text{in}}} = 1 - \frac{I_{\text{int}}}{E_{\text{in}}} \quad (4)$$

252 The exergy balance of ASU is shown as Fig.5 (a). The LU can be under three
 253 conditions these are full-LO condition without LN production, full-LN condition
 254 without LO production and liquid oxygen-nitrogen condition. The exergy balance of
 255 LU under full-LO condition is shown as Fig.5 (b), whose total exergy inputs consist
 256 of the exergy in the feed and the electricity consumption while the total exergy
 257 outputs consist of the exergy of LO and cold water. Similarly, the exergy balance of
 258 LU under full-LN condition is shown as Fig. 5(c), whose total exergy inputs consist of
 259 the exergy in the feed and the electricity consumption while the total exergy outputs
 260 consist of the exergy of LN and cold water.

261 The exergy calculation software for oxygen-nitrogen-argon mixed working fluid
 262 based on Peng–Robinson equation of state was developed by VC ++ 6.0 [24].

263 The general exergy efficiency (GEE) of ASU and LU is shown in Table 2 and
 264 Table 3. The GEE of ASU combined with LU under full-LO condition and full-LN
 265 condition is 26.33 % and 31.23 % respectively, which is 1.11 times and 1.31 times of
 266 than that of single ASU respectively. It indicates that the process of ASU with LU
 267 would be more efficient.

268 4 Energy analysis of the CVO regulation method

269 Exergy is the useful analysis method of an amount of energy that can be equally
 270 converted into work. Exergy analysis can be used to indicate thermodynamic

271 efficiency of a process, including all quality losses of materials and energies. While
 272 an energy analysis of a system is able to evaluate the energy consumption of the
 273 proposed strategy. The energy analysis for air separation unit, OCTP unit and oxygen
 274 liquefaction and vaporization unit is carried out in this section.

275 4.1 the energy analysis of the air separation unit

276 The electricity consumption of ASU varies with γ . Based on JBT 8693-1998,
 277 named standard for large and medium scale air separation unit; the consumption of
 278 unit oxygen (CUO) is calculated by Eq. (5). The CUO represents the electricity
 279 consumption of one m^3 of GO.

$$280 \quad w_{O_2} = \frac{W_{ASU}}{V_1 + 3 \sum V_{ij}} \quad (5)$$

281 where W_{ASU} is the total electricity consumption for ASU production, including the
 282 electricity of the main air compressor, auxiliary device and workshop.

283 To find effects of various γ on the electricity consumption of ASU, the CUO is
 284 calculated. Based on the actual operation data of the $40,000 \text{ m}^3 \cdot \text{h}^{-1}$ ASU, the result is
 285 shown in Fig. 6. The principle of selecting such data is as follows:

286 1) Ignoring the energy consumption of air pre-purification system; 2) Ignoring the
 287 effect of liquid product; 3) Based on the data including inlet airflow, gaseous oxygen
 288 flow and gaseous oxygen flow at rated load, both the inlet air flow and gaseous
 289 product flow changes in the same proportion, according to ref. [25].

290 The CUO has dramatic changes with various γ . With increasing the γ , the CUO
 291 reduces gradually until γ is equal to 100 %. Then the unit consumption of ASU begins

292 to increase if the γ continues to increase. The ranges of the unit consumption of ASU
 293 with different γ is from 0.459 to 0.425 kW·h ·(m³O₂)⁻¹. The CUO with γ of 80 %
 294 increases by 5.99 % compared to the one with γ under rated load condition. The effect
 295 of the load regulation process on the CUO is significant. It means that the appropriate
 296 load regulation method can save energy.

297 4.2 The electricity analysis of the oxygen compression and transportation 298 pipeline unit

299 Thus the electricity consumption of OCTP unit would induce further if the
 300 pressure of it decreases to 1.5 MPa as described in section 2.1. The electricity
 301 consumption of OC in OCTP unit is calculated by Eq. (6) [26]. Part of the
 302 compressibility factor A calculated by the program developed in section 3.2 is listed in
 303 Table 4.

$$304 \quad w_{com} = \frac{1}{\mu} \frac{k}{k-1} AR_m T \left[\left(\frac{p_{out}}{p_{in}} \right)^{\frac{k-1}{k}} - 1 \right] \quad (6)$$

305 Ignoring the exergy of cold water and the exergy loss of the compressed oxygen
 306 into the OCTP unit, the exergy analysis of the OC in OCTP unit is carried out. Its
 307 exergy inputs include the exergy of inlet oxygen and electricity consumption feeding
 308 to the OC and its exergy outputs include the exergy of outlet oxygen.

309 Fig. 7 shows the effect of different discharge pressures of oxygen/nitrogen
 310 compressors on the electricity consumption, general exergy efficiency and exergy loss
 311 of that. In Fig. 7 (a), with the discharge pressure of the OC decreasing from 3.04MPa
 312 to 1.5MPa, the electricity consumption and exergy loss of the OC reduces 30.22% and

313 38.38% respectively, while its general exergy efficiency increases from 59.67% to
 314 67.33%. Thus in order to save electricity, it is very necessary to decrease the pressure
 315 of OCTP unit. Similarly, the electricity consumption, general exergy efficiency and
 316 exergy loss of the nitrogen compressor at different discharge pressure are shown in
 317 Fig. 7 (b).

318 4.3 Comparison of three evaluation methods at different load regulation methods

319 The total electricity consumption includes that of ASU, the OCTP unit and
 320 oxygen liquefaction and vaporization unit. The total electricity consumption on three
 321 cases is compared. For CASE 1, the ALC is used on ASU as described section 2.1.
 322 For CASE 2 and CASE 3, the CVO is applied on ASU. The γ in CASE 2 raised only
 323 5 % than before while the γ in CASE 3 increases to 100 %. The γ is made equal to
 324 100 % in the above comparison process especially when the ($\gamma + 5$ %) is larger than
 325 100 %. Moreover, it is assumed that there is enough space for liquid storage tanks.

326 The total electricity on CASE 1, CASE2 and CASE3 is calculated by Eq. (7), Eq.
 327 (8) and Eq. (9) respectively. Where V_{CASE1} is the production of ASU in CASE 1; V_{use}
 328 is the user's demand; V_l is the EGO to be liquefied; w , w_{com} and w_l is the consumption
 329 of unit oxygen, the consumption of unit oxygen compression and the consumption of
 330 unit oxygen liquefaction respectively. The $V_{CASE1} \cdot w$, $V_{use} \cdot w_{com}$ and $V_l \cdot w_l$ in Eq. (7)
 331 represent the CUO, the electricity of OCTP unit and the electricity of oxygen
 332 liquefaction and vaporization unit.

$$333 \quad W_{CASE1} = V_{CASE1} \cdot w + V_{use} \cdot w_{com} + V_l \cdot w_l \quad (7)$$

$$334 \quad W_{CASE2} = V_{CASE2} \cdot w + V_{use \square CASE2} \cdot w_{com} + (V_{CASE2} - V_{use \square CASE2}) \cdot w_L \quad (8)$$

$$335 \quad W_{CASE3} = V_{CASE3} \cdot w + V_{use \square CASE3} \cdot w_{com} + (V_{CASE3} - V_{use \square CASE3}) \cdot w_L \quad (9)$$

336 The consumption of unit oxygen, calculated by Eq. (10), is fitted by the data
 337 derived from Fig.6. The consumption of unit oxygen compression is obtained by
 338 Eq.(6) . The consumption of unit oxygen liquefaction is achieved from the actual data.
 339 When $8,750 \text{ m}^3 \cdot \text{h}^{-1}$ of oxygen is liquefied, the electricity consumption of LU is 4,
 340 $956.52 \text{ kW} \cdot \text{h} \cdot \text{h}^{-1}$, thus the consumption of unit oxygen liquefaction is 0.57
 341 $\text{kW} \cdot \text{h} \cdot \text{m}^{-3} \text{O}_2$.

$$342 \quad w = 0.44277 + \frac{-0.8353}{(18.83801 \times \sqrt{\pi / 2})} \times e^{(-2 \times ((v - 98.99815) / 18.83801)^2)} \quad (10)$$

343 The daily data of supply and demand as well as liquefaction and release of
 344 oxygen during 59 days in 2009 is shown in Fig.8. The V is always beyond V_{use} . As
 345 the data in Fig.8 is randomly selected, the results could be used to analyze other days
 346 of the year 2009.

347 The effect of γ on the total electricity consumption on the three cases (CASE 1,
 348 CASE 2 and CASE 3) is shown in Fig. 9. The increase of γ suggests an increase of the
 349 total energy consumption of CASE 1 and CASE 3 as well as the gradual reduction of
 350 the total energy consumption of CASE 2. When γ varies from 84 % to 95 %, The
 351 descending order of the electricity consumption on the three cases is CASE 2, CASE
 352 3 and CASE 1, but the electricity consumption on CASE3 is closer to that on CASE 1.
 353 While γ is greater than 95 %, the electricity consumption of CASE 2 is the lowest
 354 among the three cases. It means that the total electricity consumption is influenced by

355 the γ . For several points in Fig.9, for example γ is equal to 76 %, 87 % and 90 %; the
 356 value of V_0/V_{use} is greater 1.04. Thus, it can be referred that the EGO should be
 357 released rather than be liquefied if the value of V_0/V_{use} is greater than 1.04.

358 The electricity consumption of CASE 2 is the lowest among the three cases
 359 while γ is greater than 95 %, hence the CASE 2 should be studied further by applying
 360 CER. The amount of EGO liquefied by CER is V_r . The medium pressure nitrogen
 361 (MN) is liquefied by LO to be LN which is used to liquefy the EGO.

362 Fig.10 shows a flow diagram of the cold energy recovering unit in Aspen Plus.
 363 Where, (a) represents that $1 \text{ kmol}\cdot\text{h}^{-1}$ EGO is liquefied by LN and (b) represents that 1
 364 $\text{kmol}\cdot\text{h}^{-1}$ MN is liquefied by LO. Table 5 shows the simulation conditions of CER
 365 process.

366 The simulation results show that liquefying $1 \text{ kmol}\cdot\text{h}^{-1}$ EGO need about 0.89
 367 $\text{kmol}\cdot\text{h}^{-1}$ LN, which means that the ratio of EGO and LN is 1:0.89; Liquefying 1
 368 $\text{kmol}\cdot\text{h}^{-1}$ MN need about 1.6 $\text{kmol}\cdot\text{h}^{-1}$ LO, which means that the ratio of LO and MN is
 369 1.6:1. Such ratio would not change until the temperature and pressure of product in
 370 table 5 changed.

371 The energy consumption of CER unit consists of the electricity consumption of
 372 MN compression and the cold loss of liquid product exchanging heat with gaseous
 373 product.

374 The electricity consumption of MN compression is calculated by Eq. (11).

$$375 \quad W_N = V_r \cdot 0.896 \cdot w_N \quad (11)$$

376 where W_N is the electricity consumption of MN compression; the w_N is the unit
 377 consumption of nitrogen compression, shown as Fig.7 (b).

378 The cold loss is calculated by Eq. (12).

$$379 \quad Q = V \cdot c_p \cdot \Delta t \quad (12)$$

380 where Q is cold loss; c_p is heat capacity at constant pressure; Δt is the temperature
 381 difference at warm end of CER unit.

382 Based on the conditions in table 5, the total energy consumption can be
 383 calculated by Eq. (13).

$$384 \quad W_r = V_r \cdot 0.896 \cdot w_N + \frac{V_r \cdot 0.94239 \cdot \Delta t_o}{3600} + \frac{V_r \cdot 1.0482 \cdot \Delta t_N}{1.6 \times 3600} \quad (13)$$

385 If the CER is not applied, the EGO would be released. The electricity due to the
 386 EGO released is calculated by Eq. (14).

$$387 \quad W_e = V_r \cdot w \quad (14)$$

388 where W_e is the electricity of EGO released; w is the unit consumption of oxygen,
 389 shown as Fig. 6.

390 The difference of energy consumption between CER unit and EGO released is
 391 set as ΔW . Fig. 11 shows the effect of V_r on such difference of energy consumption. It
 392 indicates that if the ASU operates stable, W_r is always smaller than W_e , which means
 393 that the total energy consumption of CER unit would decrease with increasing V_r .
 394 Thus, applying the CER unit is an energy-saving measure.

395 The CUO is selected to evaluate the electricity consumption of various methods.
 396 Table 6 lists the average of the CUO of the above three cases during 59 days in Fig. 8.

397 Regardless of electricity consumption of liquefaction, the CUO of CASE 2 and CASE
 398 3 compared to CASE 1 reduce by 2.73 % and 1.82 % respectively, and the unit
 399 consumption of oxygen compression decreases by 30 %.

400 Table 6 also reveals that the unit consumption of oxygen liquefaction is greater
 401 than of ASU and compression, which means that the electricity consumption of OCTP
 402 unit would increase because of using LU.

403 To evaluate the actual energy-saving potential of CVO method further, the
 404 overall consumption of unit oxygen (OCUO) is selected. The OCUO is defined as the
 405 ratio of the total electricity consumption and the actual amount of gaseous product V_i
 406 including the gaseous product consumed and stored but not including the released
 407 gases. The OCUO is calculated as Eq. (15)^[27]. The other product capacities of a
 408 multi-product production ASU should be converted into oxygen product capacity, the
 409 converted factor can be obtained by the minimum separation work of each component
 410 calculated by Eq. (16)^[27].

411 Here $i=1, 2$ and 3 respects O, N and Ar, respectively

$$412 \quad w_o = \frac{W_{tol}}{\sum \alpha_i V_i + 3 \sum V_{Lj}} \quad (15)$$

$$413 \quad N = nRT \sum y_i \ln \frac{1}{y_i} \quad (16)$$

414 It is assumed that air consists of O, N and Ar where the mole fraction of them is
 415 20.95%, 78.12% and 0.93% respectively. The minimum separation work of one mole
 416 of air to be separated is $62.4 \text{ kJ} \cdot (\text{m}^3 \text{ air})^{-1}$.

417 Thus the minimum separation work of oxygen is:

$$418 \quad N_1 = N/y_1 = 297.80 \text{ kJ} \cdot (\text{m}^3 \text{O}_2)^{-1}$$

419 And the minimum separation work of argon is:

$$420 \quad N_2 = N/y_2 = 6708.60 \text{ kJ} \cdot (\text{m}^3 \text{Ar})^{-1}$$

421 So, $\alpha_o = 1$, $\alpha_{Ar} = 22.527$, $\alpha_N = 0.026826$.

422 Fig. 12 shows the influence of γ on the w_o on the three cases. An increase of γ
 423 shows a reduction of the w_o . The w_o under CASE 3 and CASE 2 reduces 6.22% and
 424 4.48% compared to CASE 1 respectively. When the γ is bigger than 95 %, the w_o
 425 under CASE 3 is greater than under CASE 2, consistent with the relations of total
 426 energy shown in Fig.9. When the γ varies between 90 % and 95 %, the w_o under
 427 CASE 3 gets the minimum, and the incremental of w_o under CASE 2 compared with
 428 CASE 3 is less than 3.1%. The reason for decreasing the w_o is that the V_i increases,
 429 which is achieved by liquefying the EGO without oxygen released. However, the total
 430 electricity consumption increases due to the liquefying process. When the γ is more
 431 than 95%, the w_o under CASE 2 is minimal within the lowest total electricity
 432 consumption, because the whole EGO is liquefied rather than released.

433 To sum up, the CVO regulation method is influenced by γ . The CVO regulation
 434 method is modified based on the actual conditions as follow. When the ratio of V_o to
 435 V_{use} is less than 1.04 and the product rate is greater than 95 %, the ASU system should
 436 operate under rated load condition. While the γ varies from 85 % to 95 %, the γ should
 437 be increased by 5 %. If γ is less than 85 %, the ALC should be applied to ASU system.

438 While the ratio of V_0 to V_{use} is more than 1.04, keeping V_0 constant, the EGO should
439 be released. For example, after applying the CVO regulation method, an ASU system
440 whose production is 82,000 m³/h and its OCTP unit in particular, achieves 1.25
441 million kWh electricity-saving due to the EGO being liquefied rather than be released.

442 In China, the total oxygen consumption is about 10.91 billion m³ of O₂ while the
443 unit consumption of oxygen is assumed to be 0.42 kWh ·(m³·O₂)⁻¹ in 2013. If the
444 oxygen release ratio decreases by every 1 % of the above oxygen consumption, the
445 electricity-saving would be 4.58×10¹⁰ kWh for ASU system. As the CO₂ emission of
446 unit electricity generated by coal-fired power generation system is 1.03 kg/kWh^[28],
447 the CO₂ emissions could reduce 5.28×10⁷ tons at least annually with the above
448 energy-saving. China promised to reduce the CO₂ intensity by 40-45 % by 2020 from
449 2005 levels, and China's CO₂ emission reduction must exceed 6994.9^[29] million tons
450 to fulfill the promised CO₂ emission reduction target of China in 2020. It can be
451 inferred that the CO₂ emission reduction of iron and steel industry contributes 0.67 %
452 to China's CO₂ emission reduction in 2020 if the oxygen releasing rate decreases by
453 every 1 % of gaseous oxygen consumption in 2013.

454 5 Conclusion

455 Aiming at achieving energy savings and reducing oxygen release ratio, the
456 exergy calculation program was developed. Besides, the unit consumption of oxygen,
457 the total energy consumption and the overall unit consumption of oxygen were

458 selected to determine energy-saving of different load regulation method. After that,
459 the CVO regulation method is proposed for ASU

460 Compared with the current regulation method, the CVO regulation strategy
461 presented in the paper has following features.

462 (1) The contradiction between continuous production of ASU and fluctuant
463 demand of users can be solved, because of increase of production and storage of
464 gaseous oxygen.

465 (2) The transition speed of CVO regulation method is about 3.125 %/min twice
466 as the transition speed of current regulation method.

467 (3) The general exergy efficiency of ASU combining with liquefaction unit is
468 increased by 11 % to 31 %. The OCUO is suitable method to evaluate the
469 energy-saving potential of CVO. The OCUO and the unit consumption of
470 compression of CVO reduced more than 4.47 % and 30 %, respectively. Besides,
471 using the cold energy recovering unit is an energy-saving way.

472 (4) The proposed regulation method is related to product load rate. While the
473 product load rate is more than 95 %, the ASU operates under rated load and the CVO
474 regulation method is energy-saving.

475 **Acknowledgements**

476 This study is supported by the National Natural Science Foundation of China
477 (Grant No. 51206010), National Basic Research Program of China (973 Program)
478 (No.2012CB720406) and the CSC Scholarship.

Nomenclature			
<i>A</i>	coefficient of compressibility (-)	Superscript	
<i>c_p</i>	heat capacity at constant pressure ($\text{kJ}\cdot\text{m}^{-3}\cdot\text{C}^{-1}$)	<i>o</i>	reference conditions of enthalpy
<i>E</i>	exergy (kW)	<i>o</i>	the liquefaction unit running under full-liquid oxygen condition
<i>f</i>	fugacity (Pa)	<i>n</i>	the liquefaction unit running under full-liquid nitrogen condition
<i>H</i>	specific enthalpy ($\text{J}\cdot\text{mol}^{-1}$)	Subscript	
<i>I</i>	exergy loss (kW)	<i>ASU</i>	air separation unit system
<i>k</i>	adiabatic compressibility(-)	<i>CASE</i>	three cases analyzed in the paper
<i>N</i>	the minimum separation work ($\text{kJ}\cdot\text{m}^{-3}$)	<i>CVO</i>	combined variable oxygen method
<i>n</i>	molar (mol)	<i>com</i>	compressor
<i>p</i>	pressure (Pa)	<i>e</i>	the excess gaseous oxygen
<i>Q</i>	cold loss ($\text{kJ}\cdot\text{h}^{-1}$)	<i>gen</i>	general exergy efficiency
<i>R</i>	molar gas constant ($\text{J}\cdot\text{K}^{-1}\cdot\text{mol}^{-1}$), $8.3143 \text{ J}\cdot\text{K}^{-1}\cdot\text{mol}^{-1}$	<i>i</i>	component i
<i>T</i>	temperature (K)	<i>in</i>	inlet flow
<i>V</i>	oxygen product volume (m^3)	<i>j</i>	component j
<i>W</i>	electricity consumption (kW)	<i>l</i>	liquid product
<i>x</i>	molar fraction	<i>n</i>	the product flow under rated load
Greek Letters		<i>O</i>	oxygen
<i>α</i>	coefficient of conversion(-)	<i>O₂</i>	gaseous oxygen
<i>γ</i>	product rate (%)	<i>r</i>	cold energy recovering unit
<i>η</i>	general exergy efficiency (%)	<i>0</i>	ambient reference conditions
<i>μ</i>	efficiency of compressor (%)	<i>use</i>	user's demand of oxygen product

480 References

- 481 [1] He F, Zhang Q, Lei J, et al. Energy efficiency and productivity change of China's iron and
482 steel industry: Accounting for undesirable outputs [J]. Energy Policy, 2013, 54: 204-213.
- 483 [2] Guilin. Chen. Configuration of air separation unit for steelworks. Gas separation, 2005, (1):
484 004. (in Chinese)
- 485 [3] The crude steel production of 2012 from WORDSTEEL ASSOCIATION. Available at:
486 <http://www.worldsteel.org/zh/statistics/statistics-archive/2013-steel-production.html>,
487 08-04-2014.
- 488 [4] Zhongzhou Chen, Michael A. Henson, Senior Member, IEEE, Paul Belanger, and Lawrence

- 489 Megan. Nonlinear model predictive control of high purity distillation columns for cryogenic
490 air separation [J]. Control Systems Technology, IEEE Transactions on, 2010, 18(4): 811-821.
- 491 [5] Z.C. Guo, Z.X. Fu. Current situation of energy consumption and measures taken for energy
492 saving in the iron and steel industry in China [J]. Energy, 2010, 35 (11): 4356-4360.
- 493 [6] Lige Tong, Li Wang, Yanping Zhang, Huazhi Li. The oxygen utilization decision support
494 system and operation simulation system for air separation units [J]. Iron and Steel (Beijing),
495 2003, 38(3): 53-56.(in Chinese)
- 496 [7] Karwan MH, Kebli M. Operations planning with real time pricing of a primary input.
497 Computers & Operation Research. 2007, 34(3): 848-867.
- 498 [8] Energy information association. Manufacturing energy consumption survey. Available at:
499 <http://www.eia.doe.gov/consumption/manufacturing/data/2010/#r1.html>, 019-09-2014.
- 500 [9] Vinson D R. Air separation control technology [J]. Computers & Chemical Engineering,
501 2006, 30(10): 1436-1446.
- 502 [10] Xueshen Yang. 50000m³/h air separation plant employing quick variable-load model made by
503 Linde. Cryogenic Technology, 2003,(4): 22-25.(in Chinese)
- 504 [11] Jianqing Chen. Baosteel's practice of reducing the oxygen emission rate [J]. Energy for
505 Metallurgical Industry, 2012, 31(3): 9-10.(in Chinese)
- 506 [12] Chenglong Li. Analysis of the operation to balance the oxygen supply-demand pipeline net
507 [J]. Cryogenic Technology, 2012, (3): 10-12. (in Chinese)
- 508 [13] Luanfeng Zhai, Wenqiang Lin. Summary on measures for reducing oxygen bleeding from air
509 separation unit at steel enterprises [J]. Cryogenic Technology, 2008, (3): 61-63. (in Chinese)
- 510 [14] Junfen Liu. Automatic load control technique for air separation plants [J]. Cryogenic
511 Technology. 2002, (4): 14-16. (in Chinese)
- 512 [15] B.Roffel, B.H.LBetleln, J.A.EdeRuijter. First principles dynamic modeling and multivariable
513 control of a cryogenic distillation process [J]. Computer & Chemical Engineering, 2000, 24:
514 111-123.
- 515 [16] Lvnan Fu, Chengan Wu. Feasibility analysis of the application of interchange of LO₂ and
516 LN₂ to 10000m³/h air separation unit [J]. Cryogenic Technology, 2003, (4): 9-14. (in
517 Chinese)
- 518 [17] Xu Z, Zhao J, Chen X, et al. Automatic load change system of cryogenic air separation
519 process [J]. Separation and Purification Technology, 2011, 81(3): 451-465.
- 520 [18] R.L Cornelissen, G.G Hirs. Exergy analysis of cryogenic air separation [J]. Energy
521 Conversion and Management, 1998, 39(16): 1821-1826.

- 522 [19]Huazhi Li, Lige Tong, Ting Gao. Economic operation analysis on modern air separation unit:
523 Part II--Production with multi-product [J]. Gases Separation, 2012, (5): 19-24. (in Chinese)
- 524 [20]Enwei Sun, Changhong Sun. Technique involving recovering the refrigeration capacity of
525 liquid argon [J]. Cryogenic Technology, 2002, (5): 13-15. (in Chinese)
- 526 [21]Bernd Ameel, Christophe T'Joel, Kathleen De Kerpel, Peter De Jaeger, Henk Huisseune,
527 Marnix Van Belleghem, Michel De Paepe. Thermodynamic analysis of energy storage with a
528 liquid air Rankine cycle [J]. Applied Thermal Engineering, 2013, 52(1):130-140.
- 529 [22]Hualing Fu, Xinzhong, Shumei Cai, Jianmin Ning. Configuration and summarization of
530 operation of two sets of 40000m³/h air separation plant of Bayi Iron & Steel [J]. Cryogenic
531 Technology, 2012, (2): 17-20. (in Chinese)
- 532 [23]L.V. Van der Ham. Improving the exergy efficiency of a cryogenic air separation unit as part
533 of an integrated gasification combined cycle [J]. Energy Conversion and Management, 2012,
534 61: 31-42.
- 535 [24]Li Yao, Lige Tong, Yunfei Xie, Jianbiao Shen, Shiqi Li. Exergy Analysis for Air Separation
536 Unit [J]. Industrial Heating, 2013, (2): 22-24. (in Chinese)
- 537 [25]Fugen Xu, Jianyu Wan, Li Wang. Analysis and computation of main operating parameters for
538 variable load adjustment of air separation unit [J]. Cryogenic Technology, 2006, (04): 38-46.
539 (in Chinese)
- 540 [26]Chunyang Dong, Li Wang, Yanping Zhang. Energy consumption structure of air-separation
541 products in steel plants [J]. Journal of University of Science and Technology Beijing, 2008,
542 30(11): 1307-1311. (in Chinese)
- 543 [27]Huazhi Li. Technology of oxygen production (the second edition) [M]. Beijing: Metallurgical
544 Industry Press, 2009. (in Chinese)
- 545 [28]Ping Hou, Hongtao Wang, Hao Zhang, Dong Ci, Na Huang. Greenhouse gas emission factor
546 of Chinese power grids for organization and product carbon footprint [J]. China Environment
547 Science, 2012, 32(6): 961-967. (in Chinese)
- 548 [29]Xia Chen, Li Wang, Lige Tong. Energy saving and emission reduction of China's urban
549 district heating [J]. Energy Policy, 2013, 55: 677-682.

550

551	Tables
552	Table 1 The product index of 40, 000 m ³ /h of ASU
553	Table 2 The general exergy efficiency of ASU under rated load condition
554	Table 3 The general exergy efficiency of liquefaction unit
555	Table 4 Compressibility factor A of oxygen
556	Table 5 Simulation conditions of the cold energy recovering unit
557	Table 6 The average of the consumption of different cases

558 Figures:

559 Fig.1. Principle of oxygen system of ASU with CVO

560 Fig.2. Diagram of the liquefaction unit and the cold energy recovering unit

561 Fig.3. The pressure of oxygen compression and transportation pipeline unit

562 Fig.4. Diagram of the typical externally compressed cryogenic air separation
563 process

564 Fig.5. The exergy balance of ASU and LU

565 Fig.6. The effect of γ on the consumption of unit oxygen

566 Fig.7. The effect of different discharge pressure of oxygen (a) / nitrogen (b)
567 compressor on the energy consumption, exergy efficient and exergy loss of it

568 Fig.8. Daily data of supply and demand (a) as well as liquefaction and release (b)
569 of oxygen during 59 days in 2009

570 Fig.9. The effect of γ on the total electricity consumption of the three cases

571 Fig.10. Diagram of the cold energy recovering unit in Aspen Plus

572 Fig.11. The effect of V_r on the difference of energy consumption between W_r and
573 W_e

574 Fig.12. The influence of the γ on the overall consumption of unit oxygen

Table 1. The product index of 40,000 m³/h of ASU

Product	Production /m ³ ·h ⁻¹	Purity	Pressure /MPa(G)	Temperature/K
Oxygen gas	40,000	99.6 % O ₂	0.0191	281.25
Liquid oxygen	1,500	99.6 % O ₂	0.17	95.15
Nitrogen gas	40,000	≤3×10 ⁻⁶ O ₂	0.013	285.75
Liquid nitrogen	500	≤3×10 ⁻⁶ O ₂	0.32	80.15
Liquid argon	1,360	≤2×10 ⁻⁶ O ₂ , ≤2×10 ⁻⁶ N ₂	0.16	90.15

Table 2. The general exergy efficiency of ASU under rated load condition

Input	Exergy/kW	Output	Exergy/kW
Air in feed	0	Gaseous nitrogen	455.79
air compressor	20,600	Liquid nitrogen	121.06
Electricity consumption	400	Gaseous oxygen	2,125.29
water pump	182	Liquid oxygen	413.16
water cooler	456	Liquid argon	485.22
heating unit	33.28	Crude nitrogen	1,231.36
Cooling water in feed		Cooling water exiting	334.12
E_{in}	21,671.28	E_{out}	5,166
The GEE (η_{gen})		$E_{out}/E_{in} \times 100 \% = 23.84 \%$	

Table 3. The general exergy efficiency of liquefaction unit

Input	Exergy/KW	Output	Exergy/ KW
Electricity consumption of LU	4,956.52	Gaseous nitrogen	22.00
Middle pressure nitrogen	941.29	Liquid nitrogen	3,088.73
Gaseous oxygen in feed	816.86	Liquid oxygen	2,322.18
Cooling water in feed	128.35	Cooling water exiting	374.51
E_{in}^o	5,901.73	E_{in}^o	2,696.69
E_{in}^n	6,026.16	E_{in}^n	3,485.24
η_{gen}^o	$2,696.69/5,901.73 \times 100 \% = 46.69 \%$		
η_{gen}^n	$3,485.24/6,026.16 \times 100 \% = 57.84 \%$		

Note: the superscripts o and n represent the LU running under full-LO condition and full-LN condition respectively.

Table 4. The Compressibility factor A of oxygen

Pressure/MPa	0.5	1.0	1.5	2.0	2.5	3.0
Compressibility factor <i>A</i>	0.9977	0.9949	0.9921	0.9982	0.9866	0.9839

Table 5. Simulation conditions of the cold energy recovering unit

		Temperature/K	Pressure/MPa	Volume/(kmo·h ⁻¹)	Vapor fraction
(a)	MN	293.15	0.5	1	1
	LO	91.15	0.11	-	0
(b)	GO	293.15	1.5	1	1
	LN	80.15	1.371	-	0

Table 6. The average of the consumption of different cases

	w_{O_2} /kW·h·(m ³ O ₂) ⁻¹	w_{com} /kW·h·(m ³ O ₂) ⁻¹	w_l /kW·h·(m ³ O ₂) ⁻¹
CASE1	0.439	0.200	0.566
CVO CASE2	0.427	0.140	0.566
CVO CASE3	0.431	0.140	0.566

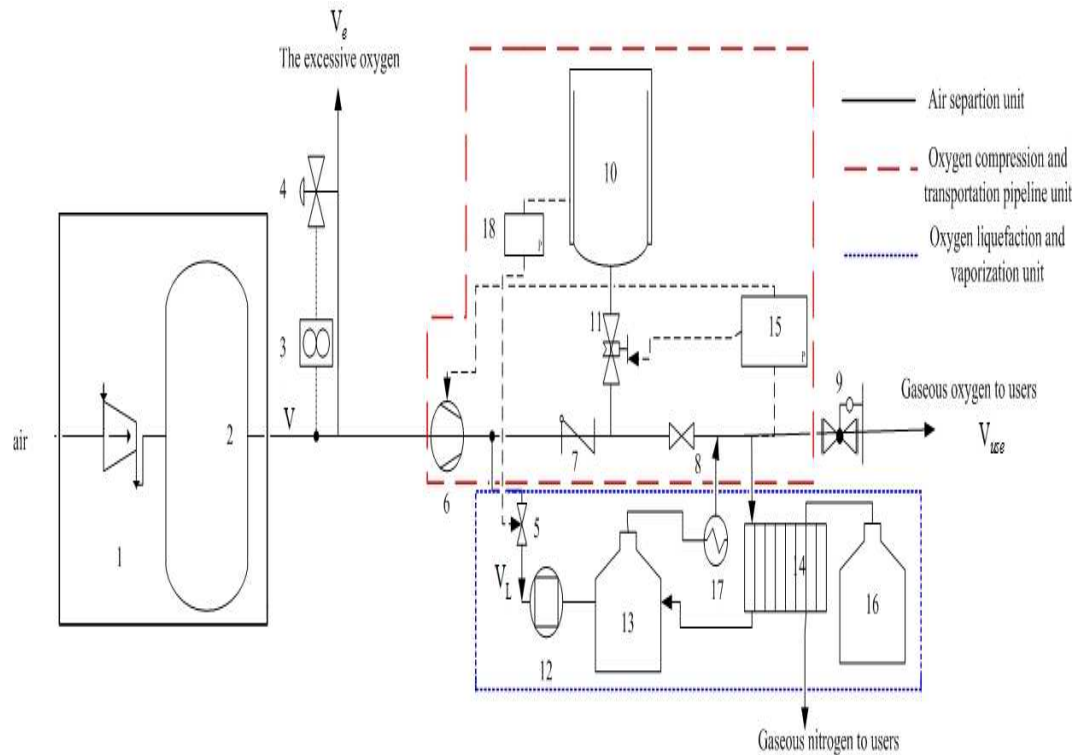

Fig. 1. Principle of oxygen system of ASU with CVO

1-air compressor; 2- distillation column; 3- flowmeter; 4- bleed valves; 5, 8-valve; 6-oxygen compressor; 7-oxygen check valve; 9- reducing valve of user; 10-spherical tank; 11- pressure control valve; 12- liquefaction unit; 13-liquid oxygen tank; 14- cold energy recovering unit; 15, 18-pressure sensor; 16-liquid nitrogen tank; 17- liquid oxygen evaporator;

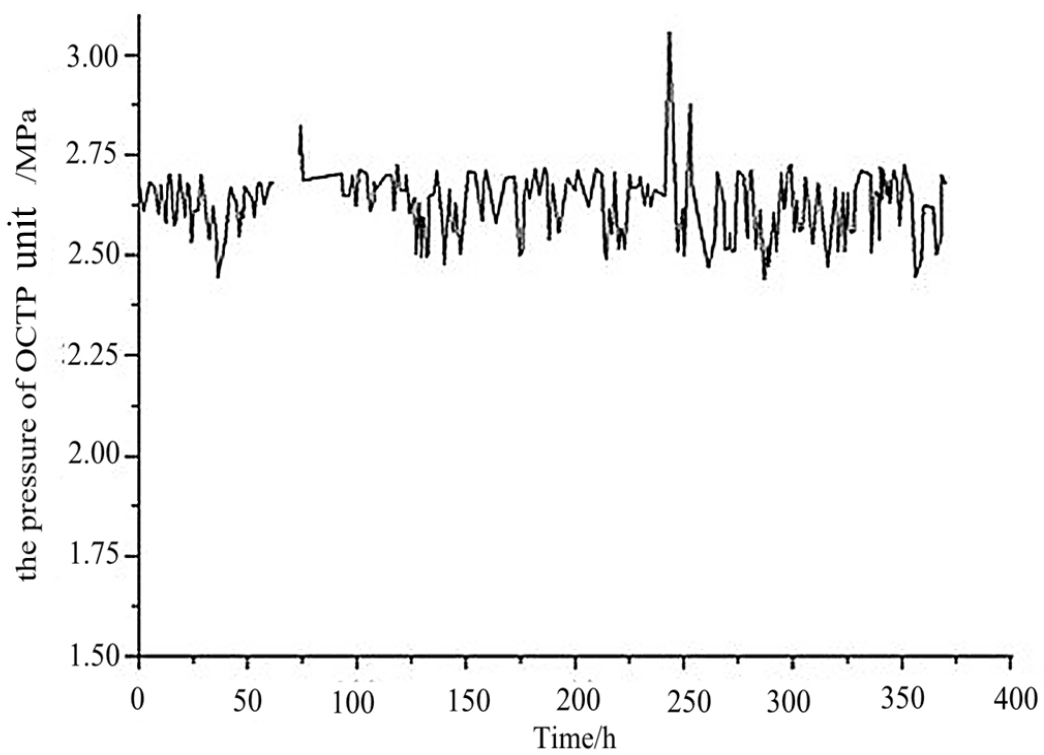

Fig. 3. The pressure of oxygen compression and transportation pipeline unit

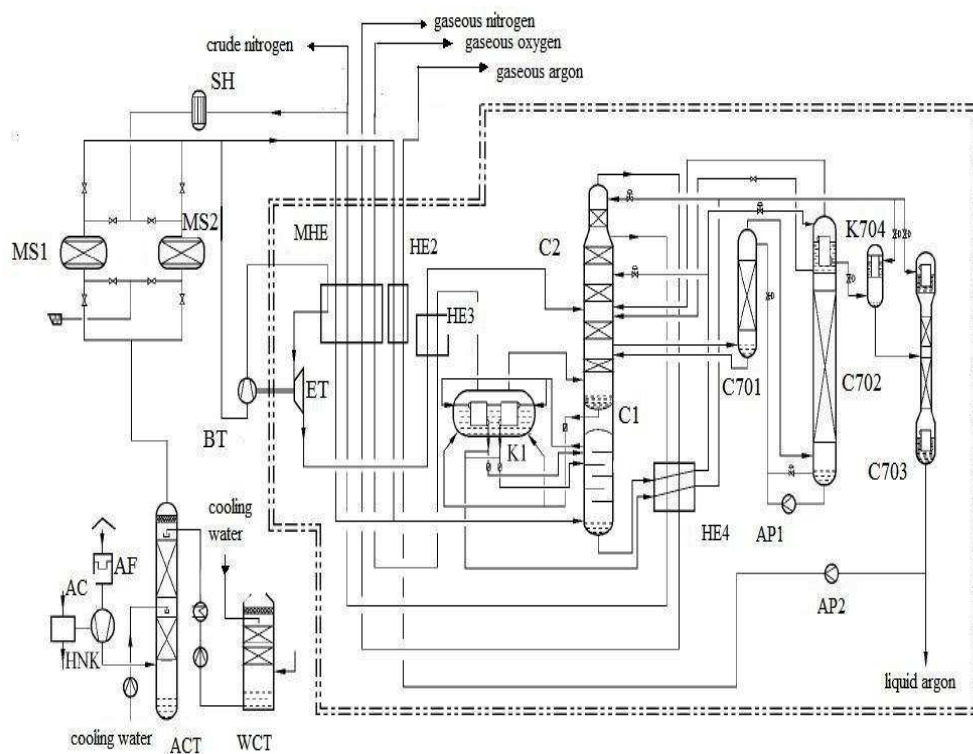

Fig. 4. Diagram of the typical externally compressed cryogenic air separation process
 AF—air filter; AC—air compressor; ACT—air cooling tower; WCT—water cooling tower;
 MS—molecular sieve purifier; SH—steam heater; BT—booster turbine; ET—expand
 turbine; MHE—main heat exchanger; HE2—heat exchanger of argon; HE3—expand air
 sub-cooler; HE4—liquid sub-cooler; K1—main cooling evaporator; C1—lower column;
 C2—upper column; C701—crude argon column I; C702—crude argon column II;
 C703—pure argon column; K704—Crude argon liquefier; AP—argon pump

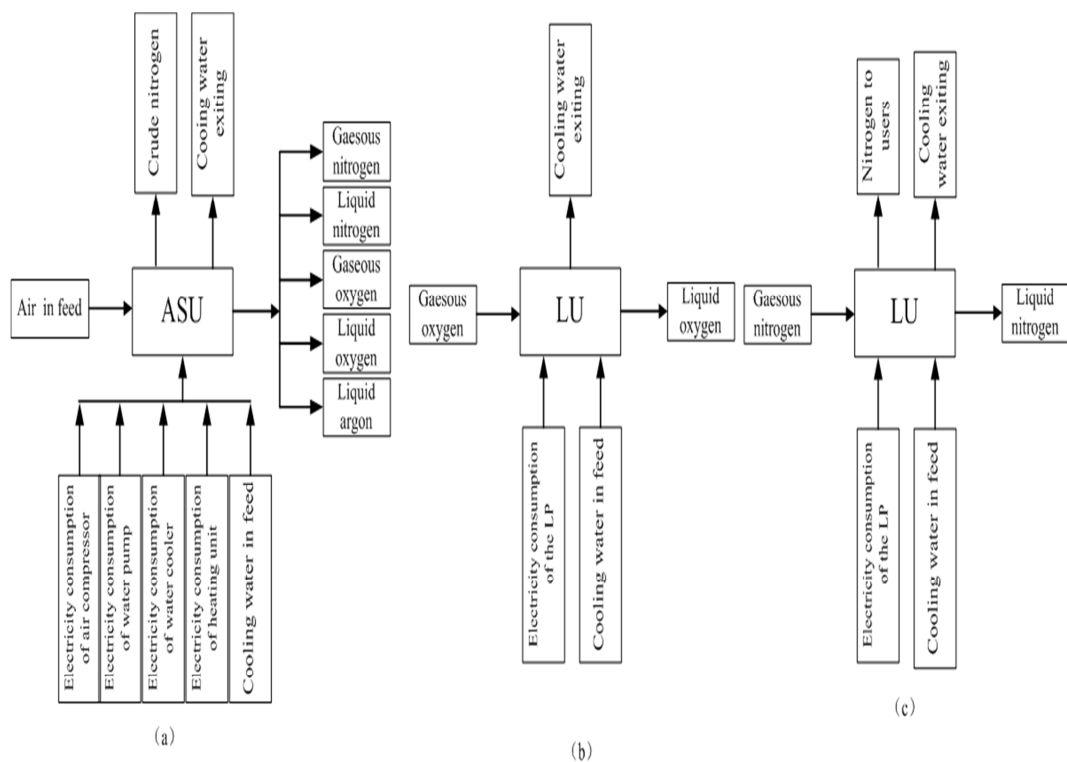

Fig. 5. The exergy balance of ASU and LU

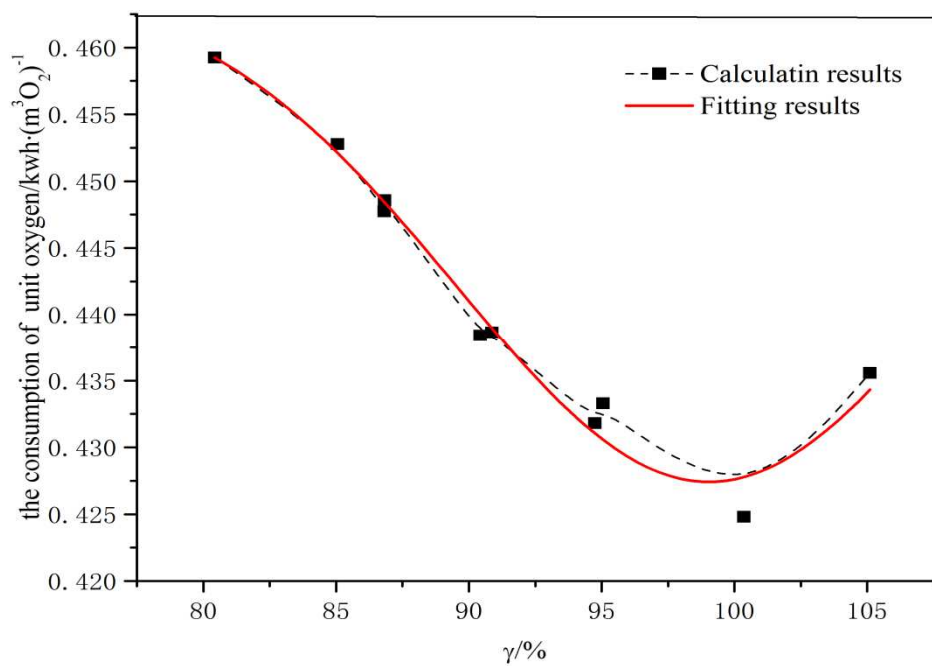

Fig. 6. The effect of γ on the consumption of unit oxygen

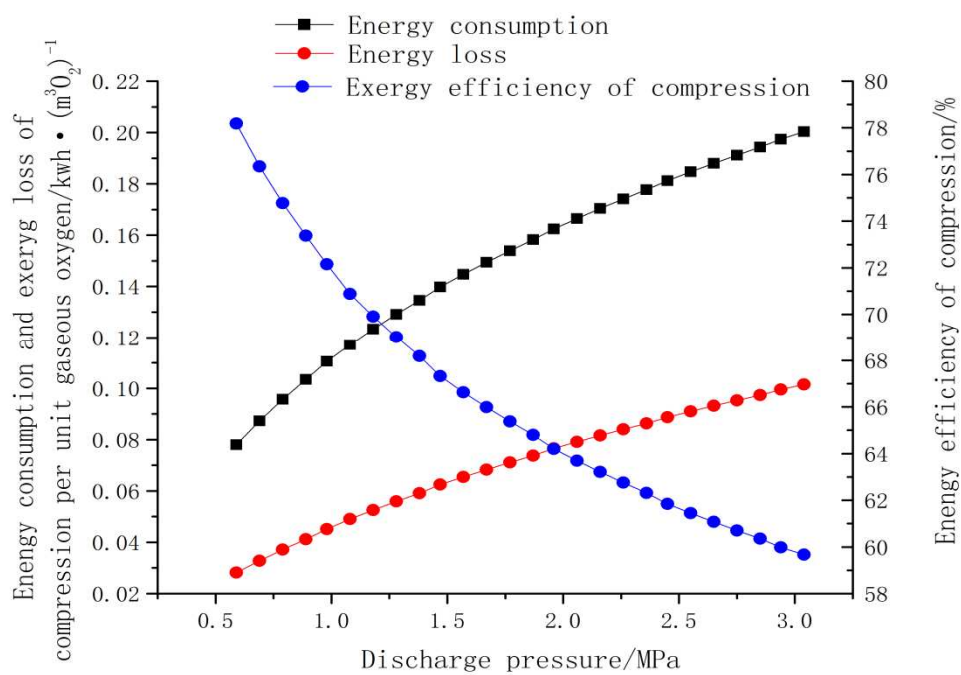

Fig. 7(a). The effect of different discharge pressure of oxygen compressor on the energy consumption, exergy efficient and exergy loss of it

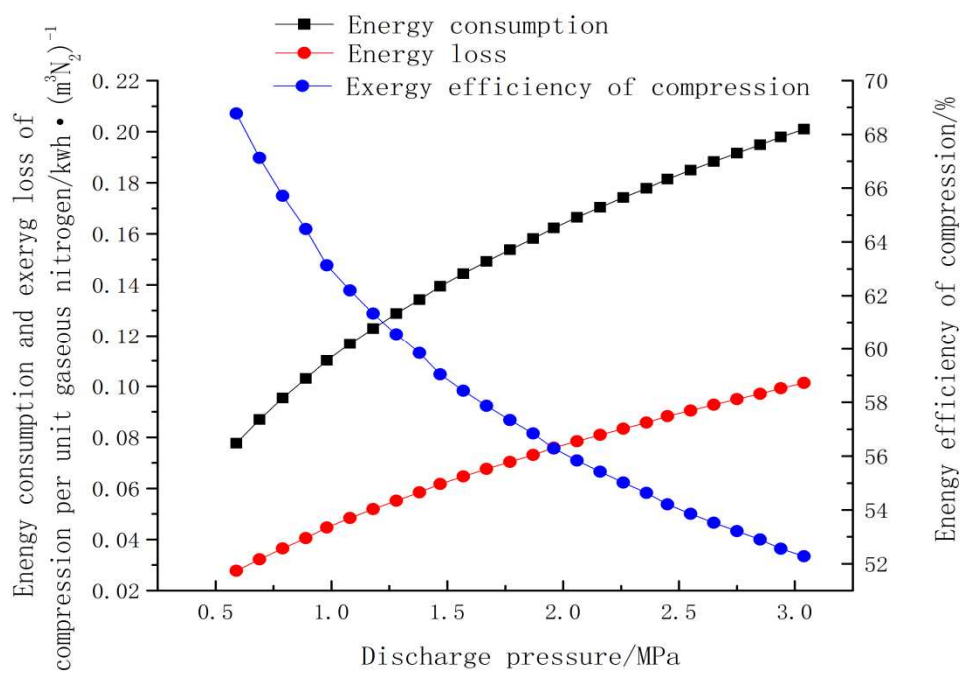

Fig. 7(b). The effect of different discharge pressure of nitrogen compressor on the energy consumption, exergy efficient and exergy loss of it

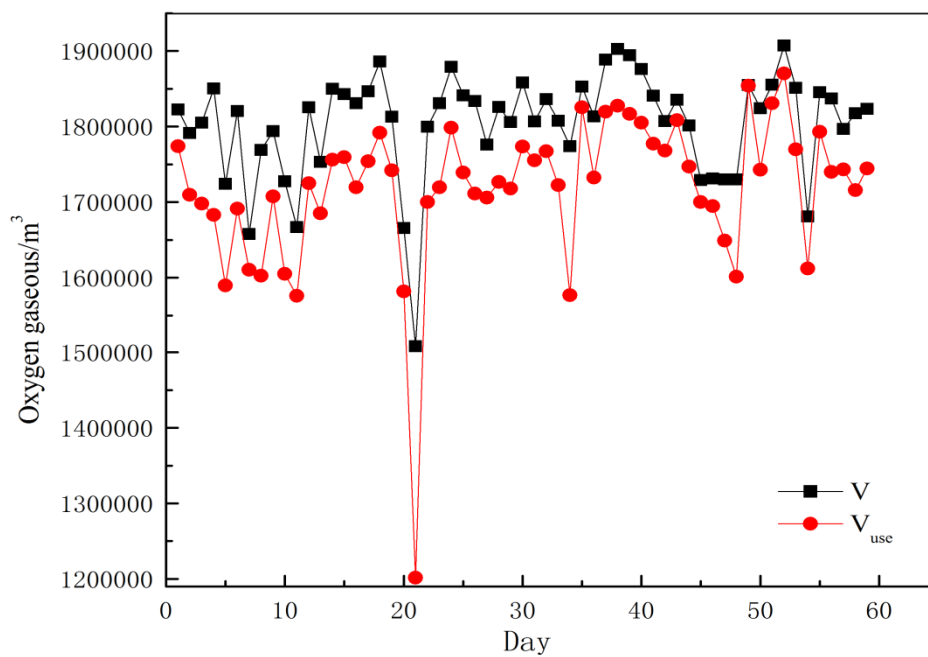

Fig. 8(a). Daily data of supply and demand of oxygen during 59 days in 2009

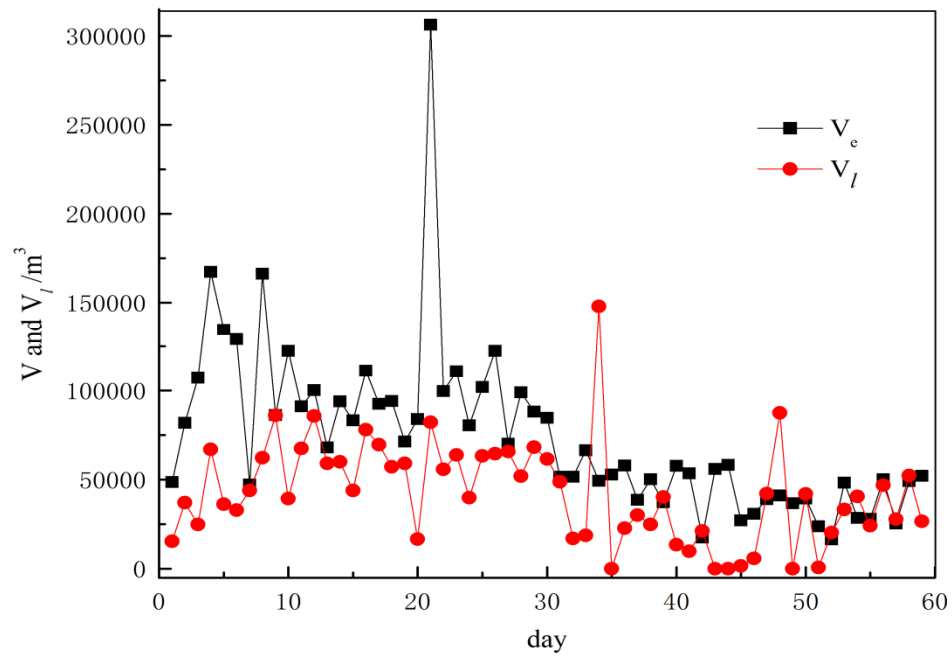

Fig. 8(b). Daily data of liquefaction and release of oxygen during 59 days in 2009

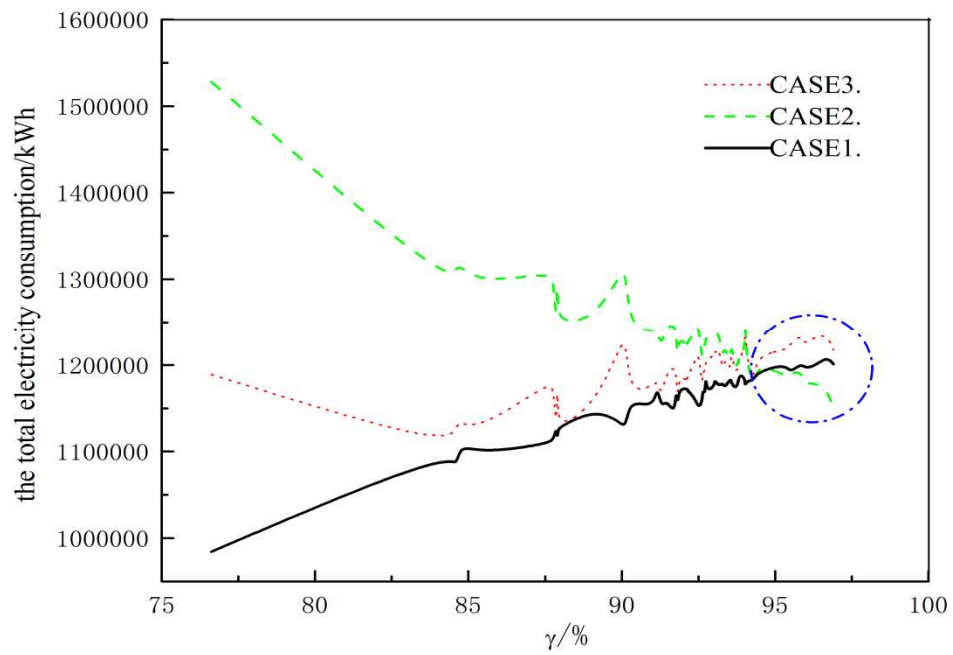

Fig. 9. The effect of γ on the total energy consumption of the three cases

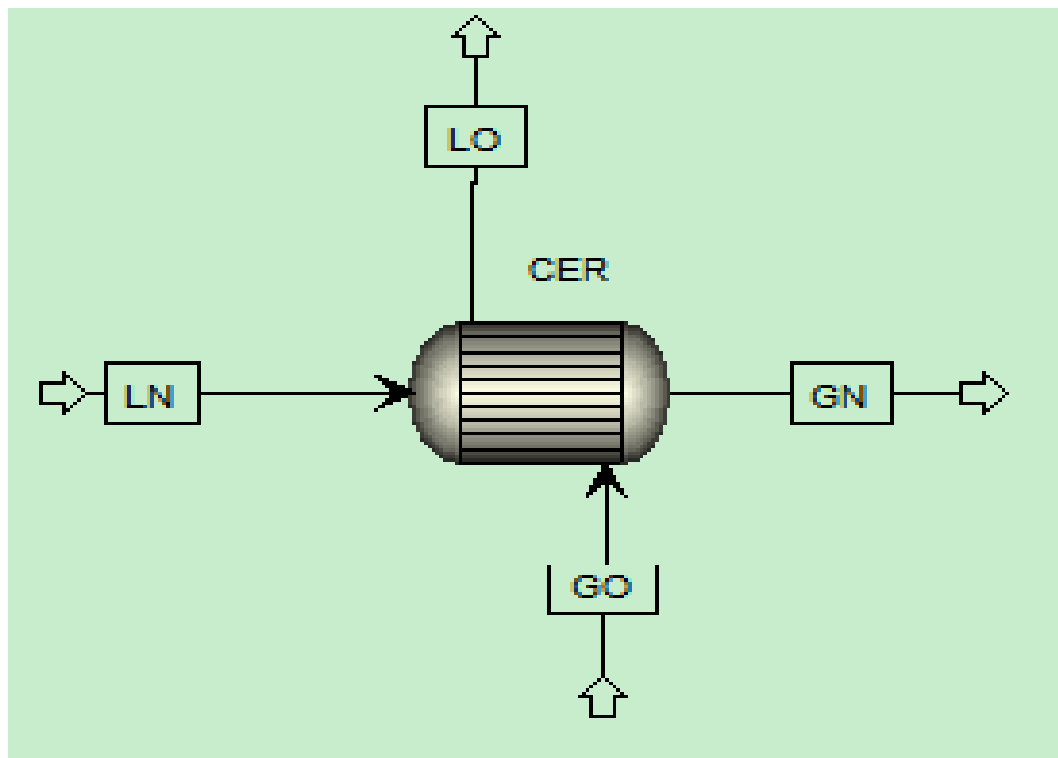

Fig. 10(a). Diagram of the cold energy recovering unit in Aspen Plus for liquid nitrogen and gaseous oxygen

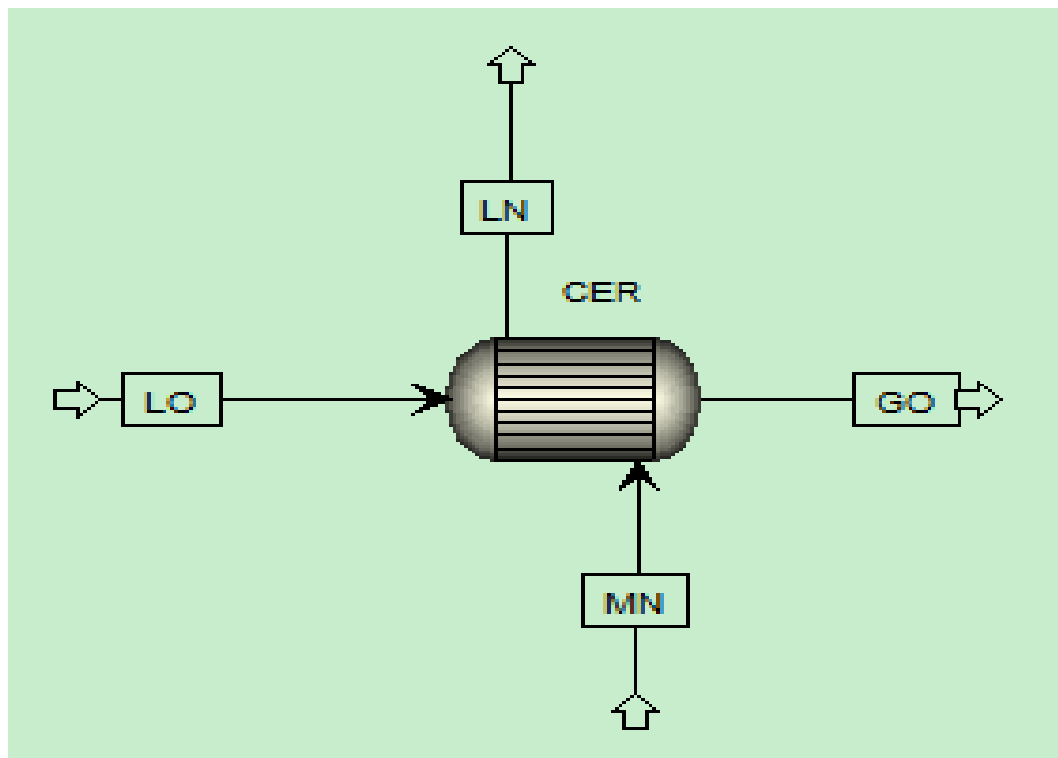

Fig. 10(b). Diagram of the cold energy recovering unit in Aspen Plus for liquid oxygen and gaseous nitrogen

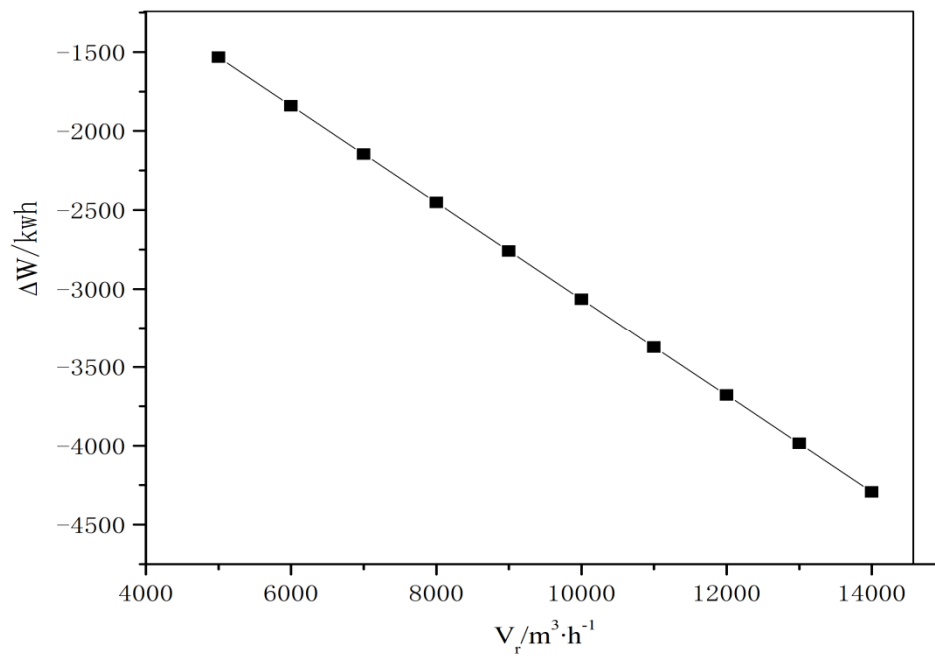

Fig. 11. The effect of V_r on the difference of energy consumption between W_r and W_e

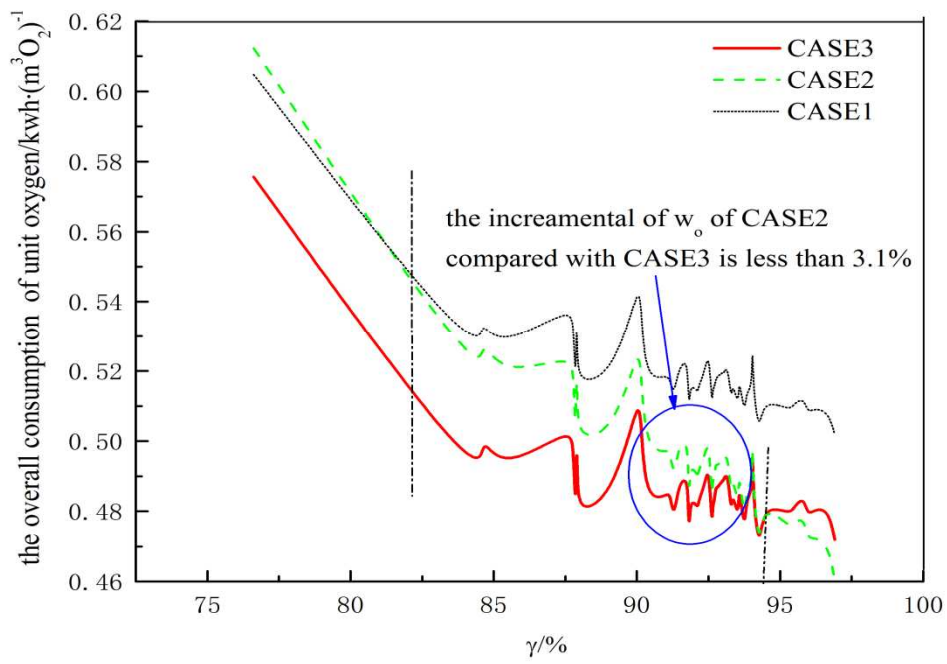

Fig. 12. The influence of the γ on the overall consumption of unit oxygen

Highlights:

- ✓ Novel regulation method of ASU to reduce the electricity consumption was proposed.
- ✓ General exergy efficiency of ASU used the new method increased by 11 %.
- ✓ Overall consumption of unit oxygen was used to evaluate energy-saving potential.
- ✓ Overall consumption of unit oxygen used CVO method reduces about 4.47 to 6.22 %.