

# Kansas Agricultural Experiment Station Research Reports

Volume 4  
Issue 2 Roundup

Article 3

2018

## Gonadotropin-Releasing Hormone Increased Pregnancy in Suckled Beef Cows Not Detected in Estrus and Subjected to a Split-Time Artificial Insemination Program

S. L. Hill

Kansas State University, [scotth22@ksu.edu](mailto:scotth22@ksu.edu)

D. M. Grieger

Kansas State University, [dgrieger@ksu.edu](mailto:dgrieger@ksu.edu)

K C. Olson

Kansas State University, [kcolson@ksu.edu](mailto:kcolson@ksu.edu)

Follow this and additional works at: <https://newprairiepress.org/kaesrr>  
See next page for additional authors

 Part of the [Other Animal Sciences Commons](#)

### Recommended Citation

Hill, S. L.; Grieger, D. M.; Olson, K C.; Jaeger, J. R.; Harmony, K. R.; Dahlen, C. R.; Crosswhite, M. R.; Negrin Pereira, N.; Underdahl, S. R.; Neville, B. W.; Ahola, J.; Fischer, M. C.; Seidel, G E.; and Stevenson, J. (2018) "Gonadotropin-Releasing Hormone Increased Pregnancy in Suckled Beef Cows Not Detected in Estrus and Subjected to a Split-Time Artificial Insemination Program," *Kansas Agricultural Experiment Station Research Reports*: Vol. 4: Iss. 2. <https://doi.org/10.4148/2378-5977.7556>

This report is brought to you for free and open access by New Prairie Press. It has been accepted for inclusion in Kansas Agricultural Experiment Station Research Reports by an authorized administrator of New Prairie Press. Copyright 2018 Kansas State University Agricultural Experiment Station and Cooperative Extension Service. Contents of this publication may be freely reproduced for educational purposes. All other rights reserved. Brand names appearing in this publication are for product identification purposes only. No endorsement is intended, nor is criticism implied of similar products not mentioned. K-State Research and Extension is an equal opportunity provider and employer.



---

# Gonadotropin-Releasing Hormone Increased Pregnancy in Suckled Beef Cows Not Detected in Estrus and Subjected to a Split-Time Artificial Insemination Program

## Abstract

Estrus-synchronization programs allow insemination of all females in a herd at one fixed time on the first day of the breeding season. Inseminating cows after they have expressed estrus increases pregnancy rate (PR) compared with cows that do not display estrus in a timed AI (TAI) program. Identification of estrus status can be facilitated by using estrus-detection patches. Varying AI timing according to estrus status has increased PR in some previous studies. Reducing the number of injections in a TAI program decreases labor requirements, stress on cows, and overall cost of the program. Previous studies have demonstrated that PR is not compromised in cows displaying estrus when the GnRH injection administered at AI is eliminated. A split-time AI program decreases the time between estrus expression and insemination compared with a single fixed-time AI when the first AI occurs before the recommended standard 60- to 66-h fixed time. Previous research has demonstrated that delaying AI results in approximately 50% more cows displaying estrus when compared with a single insemination time. Eliminating the GnRH injection at AI for cows displaying estrus in a split TAI program can reduce the number of GnRH injections required and the program cost. The objective of this study was to test the hypothesis that GnRH injection concurrent with split TAI program improves PR only in cows not displaying estrus.

## Keywords

beef cattle, estrus detection, gonadotropin-releasing hormone, timed artificial insemination

## Creative Commons License



This work is licensed under a [Creative Commons Attribution 4.0 License](https://creativecommons.org/licenses/by/4.0/).

## Authors

S. L. Hill, D. M. Grieger, K C. Olson, J. R. Jaeger, K. R. Harmony, C. R. Dahlen, M. R. Crosswhite, N. Negrin Pereira, S. R. Underdahl, B. W. Neville, J. Ahola, M. C. Fischer, G E. Seidel, and J. Stevenson

## **Gonadotropin-Releasing Hormone Increased Pregnancy in Suckled Beef Cows Not Detected in Estrus and Subjected to a Split-Time Artificial Insemination Program**

*S.L. Hill,<sup>1</sup> D.M. Grieger,<sup>1</sup> KC Olson,<sup>1</sup> J.R. Jaeger,<sup>2</sup> K.R. Harmony,<sup>2</sup>  
C.R. Dahlen,<sup>3</sup> M.R. Crosswhite,<sup>3</sup> N. Negrin Pereira,<sup>3</sup> S.R. Underdahl,<sup>3</sup>  
B.W. Neville,<sup>4</sup> J. Abola,<sup>5</sup> M.C. Fischer,<sup>5</sup> G.E. Seidel,<sup>6</sup> and J.S. Stevenson<sup>1</sup>*

### **Introduction**

Estrus-synchronization programs allow insemination of all females in a herd at one fixed time on the first day of the breeding season. Inseminating cows after they have expressed estrus increases pregnancy rate (PR) compared with cows that do not display estrus in a timed AI (TAI) program. Identification of estrus status can be facilitated by using estrus-detection patches. Varying AI timing according to estrus status has increased PR in some previous studies. Reducing the number of injections in a TAI program decreases labor requirements, stress on cows, and overall cost of the program. Previous studies have demonstrated that PR is not compromised in cows displaying estrus when the GnRH injection administered at AI is eliminated. A split-time AI program decreases the time between estrus expression and insemination compared with a single fixed-time AI when the first AI occurs before the recommended standard 60- to 66-h fixed time. Previous research has demonstrated that delaying AI results in approximately 50% more cows displaying estrus when compared with a single insemination time. Eliminating the GnRH injection at AI for cows displaying estrus in a split TAI program can reduce the number of GnRH injections required and the program cost. The objective of this study was to test the hypothesis that GnRH injection concurrent with split TAI program improves PR only in cows not displaying estrus.

### **Experimental Procedures**

A total of 1,236 mixed-parity suckled beef cows at 12 locations in 3 states (Colorado, Kansas, and North Dakota) were enrolled in the experiment. Body condition scores ((BCS) 1 = thin and 9 = obese) were assigned (d -17) before the start of the TAI pro-

---

<sup>1</sup> Department of Animal Sciences and Industry, Kansas State University, Manhattan, KS.

<sup>2</sup> Western Kansas Agricultural Research Center, Kansas State University, Hays, KS.

<sup>3</sup> Department of Animal Sciences, North Dakota State University, Fargo, ND.

<sup>4</sup> Central Grasslands Research Extension Center, North Dakota State University, Streeter, ND.

<sup>5</sup> Department of Animal Sciences, Colorado State University, Ft. Collins, CO.

<sup>6</sup> Department of Biomedical Sciences, Colorado State University, Ft. Collins, CO.

gram by a trained evaluator (Figure 1). Characteristics of suckled beef cows enrolled by location including breed, parity, days postpartum at split TAI, and BCS at the onset of the synchronization program are summarized (Table 1). All cows were injected intramuscularly with 100 µg GnRH (2 mL Factrel; Zoetis Inc., Florham Park, NJ) 7 d before 25 mg PGF<sub>2α</sub> on d 0 (5 mL Lutalyse; Zoetis Inc.). A new progesterone-impregnated controlled internal drug release (CIDR) insert (Zoetis Inc.) containing 1.38 g progesterone was placed intravaginally at the time of the GnRH injection (d -7). Progesterone inserts were removed and PGF<sub>2α</sub> was injected at 6:00 pm on d 0 to allow for AI to begin 65 h later at 11:00 am. The 84-h time was selected to begin the late AI time as soon as daylight would allow (6:00 am) and to allow insemination of cows approximately 5- to 13-h before ovulation induced by GnRH 19 h earlier. Ovulation occurs between 24 and 32 h after exogenous GnRH in cattle.

On d 0, concurrent with CIDR insert removal, estrus-detection patches (Estroprotect, Spring Valley, WI) were affixed to the tail head of all cows according to the manufacturer's recommendation. Patches were evaluated at 65 h after CIDR insert removal, and estrus was defined to have occurred when an estrus-detection patch was >50% colored (activated). Cows with activated patches were assigned by random chute order to either receive 100 µg GnRH and early AI at 65 h (E+G) or AI only at 65 h (E-G). Remaining nonestrous cows received either 100 µg GnRH at 65 h and late AI at 84 h (L+G) or AI only at 84 h (L-G). An additional evaluation of patch activation status was also conducted at 84 h to determine if activation had occurred between 65 and 84 h.

### *Pregnancy Diagnosis*

Cows were either observed for estrus and reinseminated on subsequent estrus or were exposed to cleanup bulls beginning 10 to 12 d after split TAI. At 35 d after split TAI, PR was confirmed by transrectal ultrasonography (Aloka 500V, 5 MHz transrectal transducer, Wallingford, CT). A final pregnancy diagnosis was determined via transrectal ultrasonography or palpation per rectum no sooner than 35 d after the end of the breeding season (range of 35 to 42 d). Pregnancy loss was defined as those cows pregnant 35 d after split TAI but not at the appropriate stage of pregnancy at the time of the final pregnancy diagnosis.

### *Estrus-Cycle Status*

Blood samples were collected via puncture of a caudal blood vessel from cows (n = 427) at 8 of the 12 locations on d -17 and -7. Concentrations of progesterone in blood serum were measured. Cows with a serum progesterone concentration ≥ 1.0 ng/mL at either d -17 or -7 were defined to have resumed estrous cycles. All other sampled cows with concentrations of progesterone < 1.0 ng/mL were considered to have been anestrous at the onset of the ovulation synchronization program (Table 1).

## **Results and Discussion**

### *Pregnancy Rate*

Cows detected in estrus and inseminated at 65 h had greater PR than the cows inseminated at 84 h regardless of GnRH treatment (Figure 2). Pregnancy rate was not improved ( $P = 0.68$ ) by administration of GnRH in cows that were in estrus by 65 h

(61.9 and 60.4% for E+G and E–G, respectively). For cows inseminated at 84 h, PR was greater ( $P = 0.001$ ) in cows that received GnRH at 65 h (L+G) compared with their herd mates not receiving GnRH at 65 h (41.7 and 30.8% for L+G and L–G, respectively).

Four cows were eliminated from the analysis of PR because patch data were not available at 84 h. Administration of GnRH at 65 h increased ( $P < 0.01$ ) PR in cows not detected in estrus by 84 h (Figure 3). In contrast, administration of GnRH did not impact PR ( $P = 0.60$ ) in cows expressing estrus during the interval from 65 to 84 h. Pregnancy rate for cows inseminated at either time was not affected ( $P \geq 0.10$ ) by BCS, parity, or days postpartum at AI. Final PR assessed at least 35 d after the end of the breeding season for E+G, E–G, L+G, and L–G cows were 87.4, 89.0, 84.5, and 78%, respectively. Final PR of L–G cows differed from E+G ( $P = 0.02$ ) and E–G cows ( $P = 0.004$ ). Body condition score did not affect final PR. An interaction ( $P = 0.05$ ) was detected between days postpartum and parity when considering the final PR. Primiparous cows that were  $\leq 82$  d postpartum had a lesser ( $P = 0.003$ ) final PR than primiparous cows  $> 82$  d (70.9 vs. 87.6%, respectively). Final PR of primiparous cows  $\leq 82$  d postpartum also differed ( $P = 0.01$ ) from that of multiparous cows  $\leq 82$  d and multiparous cows  $> 82$  d (87.8 and 89.7%, respectively).

### *Occurrence of Estrus*

Activated estrus-detection patches were observed in 61.3% (758/1,236) of cows at 65 h after insert removal. Of the remaining cows, 42.2% (200/474) had activated estrus-detection patches at 84 h, indicating estrus had occurred between 65 and 84 h. In total, 77.5% (958/1,236) of cows were observed with activated estrus-detection patches by 84 h.

The proportion of cows expressing estrus by 65 h was not impacted ( $P > 0.10$ ) by BCS, parity, days postpartum (Table 2), or their respective interactions. Likewise, the proportion of cows expressing estrus during the interval from 65 to 84 h was not influenced ( $P > 0.10$ ) by BCS, parity, days postpartum, or their respective interactions. A greater proportion of cows  $> 82$  d postpartum tended ( $P = 0.09$ ) to express estrus by 84 h compared with cows  $\leq 82$  d postpartum (79.8 vs. 75.5%, respectively).

Estrus-cycle status based on concentrations of progesterone was examined for its effect on occurrence of estrus in the subset of 427 cows for which that information was available. Analysis of the impact of estrus-cycle status on estrus expression revealed that similar ( $P > 0.26$ ) proportions of cycling and anestrus cows were detected in estrus in each of the 3 observation periods (51 vs. 58% by 65 h, 25 vs. 28% between 65 and 84 h, and 65 vs. 70% by 84 h for cycling and anestrus cows, respectively). The proportion of cows that had resumed estrous cycles (32.3%; 138/427) was influenced by neither BCS nor days postpartum. Primiparous cows, however, were more ( $P < 0.01$ ) likely to be anestrus than their multiparous herd mates (94.6 vs. 63.6%, respectively).

### **Implications**

Injection of GnRH at AI improved PR only in those cows that were not detected in estrus before time of AI. Cows that exhibited estrus, regardless of GnRH treatment,

had better PR than cows that did not display estrus. Insemination at a predetermined time in beef cows can reduce the time and labor associated with a conventional single standard fixed-time AI program. The split-time AI program serves as a compromise between conventional AI after detection of estrus and a standard one fixed-time AI program. Depending on the cost of GnRH (range of US \$2.22 to \$3.10 per dose) and 60% of cows in estrus by 65 h, the economic trade-off of using estrus-detection patches in a split-time AI program is favorable and saved \$0.33 to \$0.86 per cow. However, it does not account for the extra time and cow–calf handling invested to carry out the second AI at 84 h. The cost of semen and sire selection for cows detected in estrus having a greater PR compared with those not detected in estrus and lesser PR could provide other favorable options and economic advantages for using a split-time AI program.

**Table 1. Selected characteristics of suckled beef cows enrolled in the experiment**

Location <sup>1</sup>	Breed <sup>2</sup>	n	2-year-old %	Day	BCS <sup>3</sup>	Estrus cycle	Pregnancy
				postpartum at AI		status <sup>4</sup>	rate <sup>5</sup>
						----- % -----	
CO-1	A	333	26	83 ± 1.0	4.6 ± 0.02	<sup>-6</sup>	58.9
CO-2	A	80	23	81 ± 1.9	5.5 ± 0.08	<sup>-6</sup>	68.8
KS-1	H	39	28	78 ± 2.9	5.6 ± 0.08	33	66.7
KS-2	A × H	40	25	82 ± 2.6	5.7 ± 0.10	53	45.0
KS-3	A × H	77	31	84 ± 1.7	5.4 ± 0.07	61	49.4
KS-4	A × H	61	26	83 ± 1.8	5.4 ± 0.09	49	55.7
KS-5	A × H	64	86	78 ± 2.6	5.5 ± 0.08	6	23.4
KS-6	A × H	98	0	69 ± 1.8	5.7 ± 0.06	18	46.9
KS-7	A × H	29	0	49 ± 3.8	5.8 ± 0.07	14	51.7
KS-8	A × H	19	0	69 ± 4.2	5.3 ± 0.18	5	21.1
ND-1	A × H	190	0	72 ± 1.4	4.4 ± 0.04	<sup>-6</sup>	68.9
ND-2	A × H	206	32	83 ± 1.2	4.3 ± 0.04	<sup>-6</sup>	62.6

<sup>1</sup>Cows at 12 locations in 3 states were enrolled. CO = Colorado; KS = Kansas; and ND = North Dakota.

<sup>2</sup>A = Angus and H = Hereford.

<sup>3</sup>Mean ± SE.

<sup>4</sup>Based on progesterone concentrations measured in 2 blood samples collected 10 d apart before the onset of the experimental protocol in 427 cows (cut point for determining if cows were having estrus cycles was ≥ 1 ng/mL).

<sup>5</sup>Assessed at 35 d after AI.

<sup>6</sup>Blood samples were not collected to assess estrus cycle status.

**Table 2. Estrus expression by 65 h, between 65 and 84 h, and by 84 h after controlled internal drug release insert removal as affected by BCS, parity, days postpartum, and GnRH**

Item	Estrus by 65 h		Estrus between 65 and 84 h		Estrus by 84 h	
	n	%	n	%	n	%
Days postpartum						
≤82	596	61.1	229	37.9	596	75.5 <sup>a</sup>
>82	640	65.8	245	41.6	640	79.8 <sup>b</sup>
BCS						
≤5	689	64.3	269	41.8	689	79.3
>5	547	62.6	205	37.7	547	76.1
Parity						
Primiparous	287	64.2	119	37.5	287	77.1
Multiparous	949	62.7	355	42.0	949	78.4
GnRH at 65 h	---	---	249	40.9	---	---
No GnRH at 65 h	---	---	225	38.6	---	---

<sup>ab</sup>Means within estrus category with different superscript letters tend ( $P < 0.10$ ) to differ.

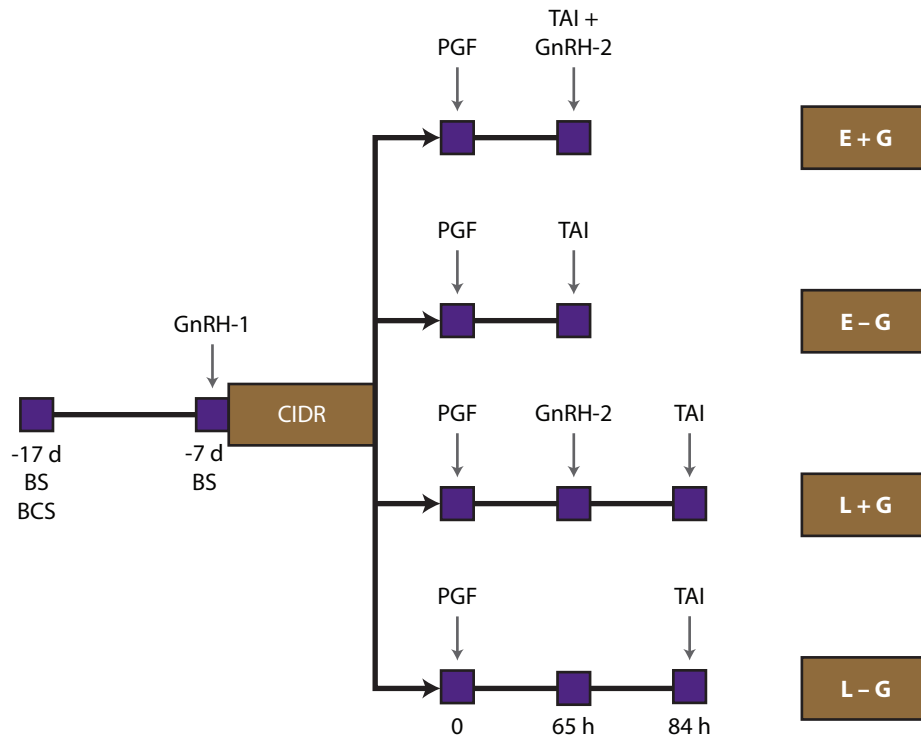

**Figure 1. Experimental design of treatments.** All cows ( $n = 1,236$ ) received intramuscularly  $100 \mu\text{g}$  GnRH (GnRH-1) and a controlled internal drug release (CIDR) insert containing  $1.38 \text{ g}$  of progesterone followed in 7 d by  $25 \text{ mg}$   $\text{PGF}_{2\alpha}$  (PGF) and CIDR removal (d 0). Cows with patches  $>50\%$  activated were defined to be in estrus and treatment assignments were made at 65 h. The  $100 \mu\text{g}$  GnRH and early AI at 65 h (E+G) cows ( $n = 373$ ) received  $100 \mu\text{g}$  GnRH (GnRH-2) and insemination at 65 h. The AI only at 65 h (E-G) cows ( $n = 385$ ) received no GnRH and were inseminated at 65 h. The  $100 \mu\text{g}$  GnRH at 65 h and late AI at 84 h (L+G) cows ( $n = 252$ ) received GnRH at 65 h and were inseminated at 84 h. The AI only at 84 h (L-G) cows ( $n = 226$ ) received no GnRH and were inseminated at 84 h. Body condition scores (BCS; 1 = thin and 9 = obese) were assigned (d -17) before the start of the TAI program. Blood samples (BS) were collected on d -17 and -7 from a subset of cows ( $n = 427$ ) at 8 of 12 locations. TAI = timed AI.



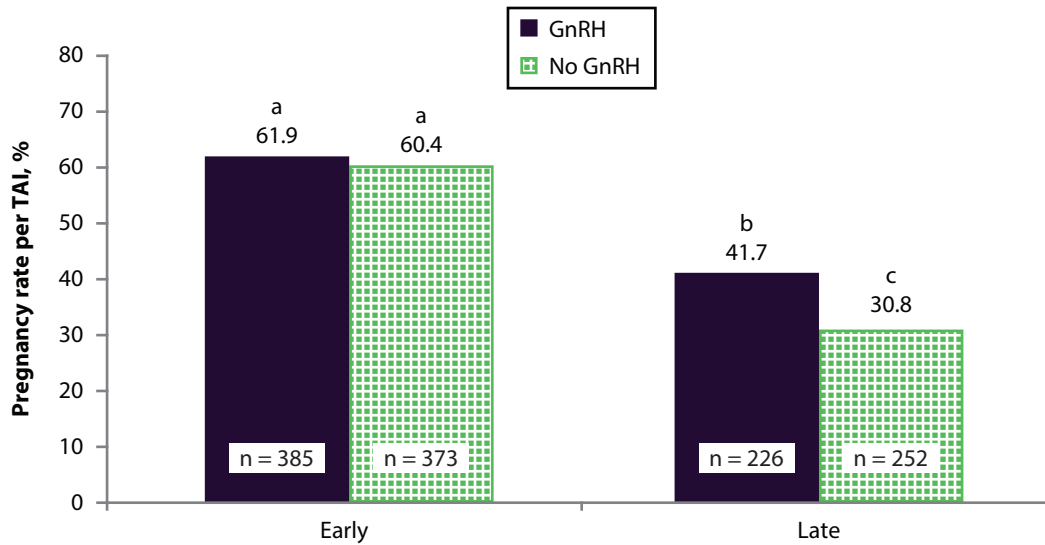

**Figure 2. Pregnancy rate (PR) per timed AI (TAI) by treatment.** The early cows were detected in estrus by 65 h, inseminated, and either received GnRH at 65 h (E+G) or did not receive GnRH (E-G). The remaining cows were allocated to 2 late treatments: 1) injected with GnRH at 65 h and inseminated at 84 h (L+G) or 2) no GnRH at 65 h and inseminated at 84 h (L-G).

<sup>a,b,c</sup>Bars with different letters differ ( $P < 0.05$ ). Values at the base of each bar represent the number of cows per treatment.

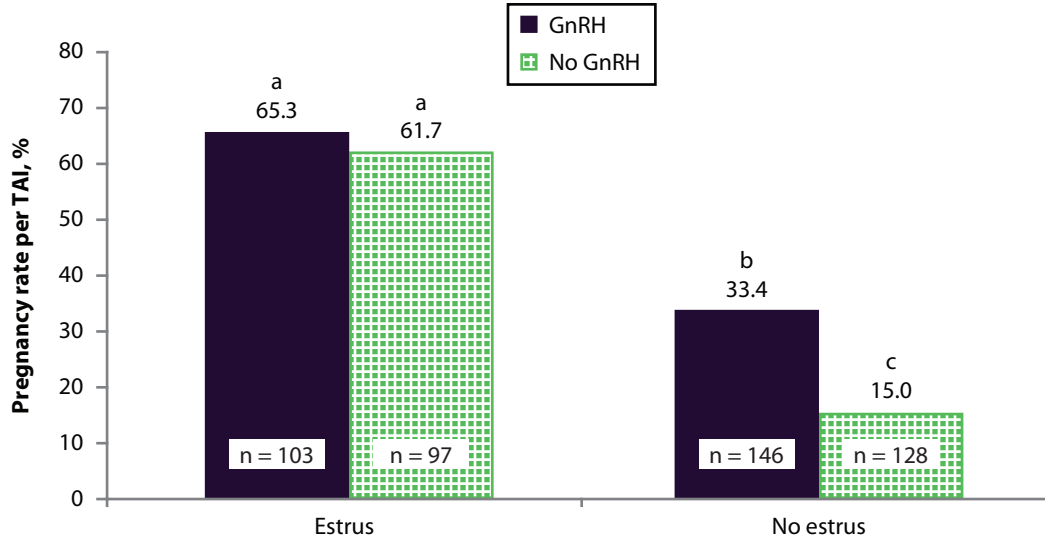

**Figure 3. Pregnancy rate (PR) per timed AI (TAI) for cows inseminated at 84 h.** Based on whether the estrus-detection patch was >50% activated between 65 and 84 h after controlled internal drug release insert removal, cows were classified at estrus or no estrus.

<sup>a,b,c</sup>Bars with different letters differ ( $P < 0.05$ ). Values at the base of each bar represent the number of cows per treatment.