

Digital Commons
@ LMU and LLS

Digital Commons@
Loyola Marymount University
and Loyola Law School

Mechanical Engineering Faculty Works

Mechanical Engineering

4-1-2007

Warpage Behavior of 7075 Aluminum Alloy Extrusions

Omar S. Es-Said

Loyola Marymount University, oessaid@lmu.edu

T. M. Ruperto

S. L. Vasquez

A. Y. Yue

D. J. Manriquez

See next page for additional authors

Repository Citation

Es-Said, Omar S.; Ruperto, T. M.; Vasquez, S. L.; Yue, A. Y.; Manriquez, D. J.; Quilla, J. C.; Harris, S. H.; Hannan, S.; Foyos, J.; Lee, E. W.; Pregger, B.; Abourialy, N.; and Ogren, J., "Warpage Behavior of 7075 Aluminum Alloy Extrusions" (2007). *Mechanical Engineering Faculty Works*. 6.

http://digitalcommons.lmu.edu/mech_fac/6

Recommended Citation

Es-Said, O.S., Ruperto, T.M., Vasquez, S.L., Yue, A.Y., Manriquez, D.J., Quilla, J.C., Harris, S.H., Hannan, S., Foyos, J., Lee, E.W., Pregger, B., Abourialy, N., and Ogren, J., 2007, "Warpage Behavior of 7075 Aluminum Alloy Extrusions," *Journal of Materials Engineering and Performance*, **16**(2), pp. 242-247.

Authors

Omar S. Es-Said, T. M. Ruperto, S. L. Vasquez, A. Y. Yue, D. J. Manriquez, J. C. Quilla, S. H. Harris, S. Hannan, J. Foyos, E. W. Lee, B. Pregger, N. Abourialy, and J. Ogren

Warpage Behavior of 7075 Aluminum Alloy Extrusions

O.S. Es-Said, T.M. Ruperto, S.L. Vasquez, A.Y. Yue, D.J. Manriquez, J.C. Quilla, S.H. Harris, S. Hannan, J. Foyos, E.W. Lee, B. Pregger, N. Abourialy and J. Ogren

(Submitted August 9, 2006)

Extruded I sections of 7075-T6 aluminum were machined into four different sections shapes: L, short depth L, T, and short depth T. The furnace was preheated to 416 °C (780 °F) and the samples were placed inside. The temperature was raised to 471 °C (880 °F) and then the samples were quenched in either a 30% polyalkylene Glycol solution or water, both at 15 °C (59 °F). Points on the distorted samples were recorded before and after the solution treatment; the difference between the measurements indicated the extent of warpage.

Keywords 7075 extrusions, varying section shapes, warpage

1. Introduction

Heat treatable aluminum alloys are quenched from the solution treating temperature, typically between 466 °C (870 °F) and 566 °C (1050 °F), to achieve a supersaturated solid solution prior to controlled artificial age hardening, (Ref 1, 2). Agitated cold water quenching often results in distortion (warpage) of the parts and development of high residual stresses, (Ref 1-3). The high cooling rate produces large temperature gradients between thick and thin sections which causes localized plastic flow, which in turn results in warpage after quenching or during machining, (Ref 1).

Warpage is a major problem, which leads to laborious, expensive, and time consuming straightening operations and in some cases to scrapping of large expensive parts, (Ref 4). Warpage can be minimized by adding polymers to water quenchants to reduce the convective or film coefficient between the part and the water, (Ref 5-8). These synthetic quenchants retard the heat transfer from the components surface and reduce the temperature differential between different thicknesses of the material, (Ref 1, 2, 4).

Much work has been reported in efforts to reduce warpage, (Ref 6-9), however, systematic studies are needed to characterize warpage profiles as a function of manufacturing method (rolled plates, extrusions, forgings...), variations in thickness of similar shapes, variation in thickness of a component, section shape, and the like.

Foyos et al. (Ref 10) determined the warpage of 7050 aluminum alloy I and C sections by a height gage and surface plate, Konyukov et al. (Ref 11) measured the warpage of

aluminum samples from the deviation from the plane of the supporting plate at different points along the perimeter and Maidment (Ref 12) measured the flatness of the samples with a Zeiss SMM instrument at several points.

In this paper an experiment is carried out to determine the effect of section shape and web depth on the warpage behavior of 7075 extrusions. The effects of two quenchants: water (high film coefficient) and 30% polyalkylene glycol solution (low film coefficient) on the warpage behavior are also studied.

2. Experimental Procedure

I section extrusions of 7075-T6 aluminum alloy of 0.335 mm (0.0132 in) flange thickness, 5.6 cm (2.2 in) flange width, 0.28 cm (0.11 in) wall thickness, 17.8 cm (7.0 in) depth of the web and 30.5 cm (12 in) length were machined into L and T sections and short depth 8.9 cm (3.5 in) L and T sections. The quantitative profiles of 30 samples of five shapes (I, L, T, short depth L and T) were characterized by a Brown and Sharpe coordinate measuring machine. In this method, a point at one corner of the beam was used as a reference, labeled zero (Ref 10). The beams were clamped at the reference point and held fixed on a flat and the height was measured along the Z-axis at several points.

The extrusions of different shapes, Fig. 1(a) were placed in a furnace preheated to 416 °C (780°F), and the temperature was raised by 27.5 °C (50 °F) per hour to 471 °C for two more hours. The solution treatment proceeded at 471 °C (880°F) for two more hours. A set of three samples per shape, (I, L, T, short L and short T) was quenched in 30% glycol solution surrounded by ice at 15 °C (59 °F) and another set was quenched in water at the same temperature. Quenching was along the length of the extrusion at a rate of 7.6 cm/s (3"/s). The temperature of the quenchant and the quenching rate were chosen to amplify the warpage effect similar to the procedure of an earlier work, (Ref 10). The quantitative profiles of the samples were again characterized by the Brown & Sharpe coordinate machine. The difference between the profile measurements at different points and the angle between the web and flange in each sample before and after solution treatment quantified the amount of warpage.

O.S. Es-Said, T.M. Ruperto, S.L. Vasquez, A.Y. Yue, D.J. Manriquez, J.C. Quilla, S.H. Harris, S. Hannan, J. Foyos, and J. Ogren, Mechanical Engineering Department, Loyola Marymount University, One LMU Drive, Los Angeles, CA 90045-8145; Contact e-mail: oessaid@lmu.edu. **E.W. Lee, B. Pregger,** and **N. Abourialy,** Naval Air Systems Command, Code 4342, MS, Bldg 2188, MS05, Patuxent River, MD 2067-1908.

3. Results and Discussion

3.1 Section Shapes

The warpage profiles for the I, L and T sections are also shown schematically in Fig. 1(b).

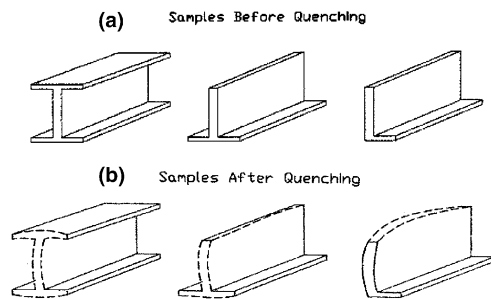

Fig. 1 (a) Extrusions of different shapes as machined. (b): Extrusions after solution treatment and quenching

3.1.1 I Sections. For the I section, Fig. 2(a), points 1-3, and 10-12 are located on the inner part of the bottom flange, points 4-9 on the outer part of the top flange and points 13-21 on the side of the web. Points 1 and 3 are 2.54 cm (1 in) away from the edges and point 2 is 15.2 cm (6 in) from both edges. Points 4-6, 7-9 and 10-12 are distributed in a similar pattern. Points 13, 16 and 19 are at the top, middle and bottom of the web, points 14, 17, 20, and 15, 18, 21 are distributed in a similar pattern. The Beams were placed in two configurations. In Fig. 2(a) the heights of all the points except 13-21 were measured along the depth of the web. In Fig. 2(b), point 13 is considered the zero position for the coordinate measuring machine. The probe is then moved to points 14-21 to identify the distortion in the length-depth of the web plane. The measurement of the same marked points was repeated after the solution treatment.

The distortion for the I sections was measured for the three samples quenched in water and three samples quenched in glycol. In Table 1, the measurements of two samples, one quenched in water and the other in Polyalkylene glycol are shown. The difference between the pre-measure and the

Table 1 The distortion in cms and in inches for water and glycol quenched I sections

Quenchant	Point	Pre-measure, in.	Pre-measure, cm	Remeasure, in.	Remeasure, cm	Difference, in.	Difference, cm
<i>Water at 59 °F Sample 1</i>							
	1	0.13111	0.3330194	0.14620	0.37135	0.01509	0.03833
	2	0.13060	0.331724	0.16197	0.41140	0.03137	0.07968
	3	0.13040	0.331216	0.19591	0.49761	0.06551	0.16640
	4	7.19864	18.2845456	7.29414	18.52712	0.09550	0.24257
	5	7.19922	18.2860188	7.30691	18.55955	0.10769	0.27353
	6	7.20058	18.2894732	7.32947	18.61685	0.12889	0.32738
	7	7.18216	18.2426864	6.93104	17.60484	-0.25112	-0.63784
	8	7.18222	18.2428388	6.93703	17.62006	-0.24519	-0.62278
	9	7.18054	18.2385716	6.98639	17.74543	-0.19415	-0.49314
	10	0.13345	0.338963	0.13926	0.35372	0.00581	0.01476
	11	0.13290	0.337566	0.14638	0.37181	0.01348	0.03424
	12	0.13096	0.3326384	0.14398	0.36571	0.01302	0.03307
	13	0.00451	0.0114554	0.20122	0.51110	0.19671	0.49964
	14	0.01561	0.0396494	0.38509	0.97813	0.36948	0.93848
	15	0.00460	0.011684	0.09188	0.23338	0.08728	0.22169
	16	0.01279	0.0324866	0.18149	0.46098	0.16870	0.42850
	17	0.02281	0.0579374	0.34866	0.88560	0.32585	0.82766
	18	0.01261	0.0320294	0.13158	0.33421	0.11897	0.30218
	19	0.02272	0.0577088	0.11047	0.28059	0.08775	0.22289
	20	0.03162	0.0803148	0.22727	0.57727	0.19565	0.49695
	21	0.01991	0.0505714	0.13208	0.33548	0.11217	0.28491
<i>30% Polyalkylene Glycol at 59 °F Sample 1</i>							
	1	0.13112	0.3330448	0.13084	0.3323336	-0.00028	-0.0007112
	2	0.13057	0.3316478	0.15693	0.3986022	0.02636	0.0669544
	3	0.13219	0.3357626	0.19681	0.4998974	0.06462	0.1641348
	4	7.20343	18.2967122	7.28350	18.50009	0.08007	0.2033778
	5	7.20480	18.300192	7.29568	18.5310272	0.09088	0.2308352
	6	7.20677	18.3051958	7.29398	18.5267092	0.08721	0.2215134
	7	7.18095	18.239613	7.02154	17.8347116	-0.15941	-0.4049014
	8	7.17984	18.2367936	7.07146	17.9615084	-0.10838	-0.2752852
	9	7.17900	18.23466	7.13017	18.1106318	-0.04883	-0.1240282
	10	0.13277	0.3372358	0.13222	0.3358388	-0.00055	-0.001397
	11	0.13222	0.3358388	0.14081	0.3576574	0.00859	0.0218186
	12	0.13187	0.3349498	0.13307	0.3379978	0.00120	0.003048
	13	0.00322	0.0081788	0.10489	0.2664206	0.10167	0.2582418
	14	0.01840	0.046736	0.29129	0.7398766	0.27289	0.6931406
	15	0.00662	0.0168148	0.05394	0.1370076	0.04732	0.1201928
	16	0.01488	0.0377952	0.07572	0.1923288	0.06084	0.1545336
	17	0.02702	0.0686308	0.27715	0.703961	0.25013	0.6353302
	18	0.01516	0.0385064	0.15915	0.404241	0.14399	0.3657346
	19	0.02298	0.0583692	0.08019	0.2036826	0.05721	0.1453134
	20	0.03565	0.090551	0.22438	0.5699252	0.18873	0.4793742
	21	0.02236	0.0567944	0.25424	0.6457696	0.23188	0.5889752

remeasure values (as received and as solution treated) are smaller for glycol quenched samples. If the units are converted to inches, also included in Table 1, the difference is in tenths to hundredths of an inch for water quenched samples and mostly in hundredths of an inch for glycol quenched samples.

3.1.2 Large Depth L Sections. For the large depth L section, Fig. 3, points 1-6 are located on the inner part of the bottom flange and on the top of the web depth along the length.

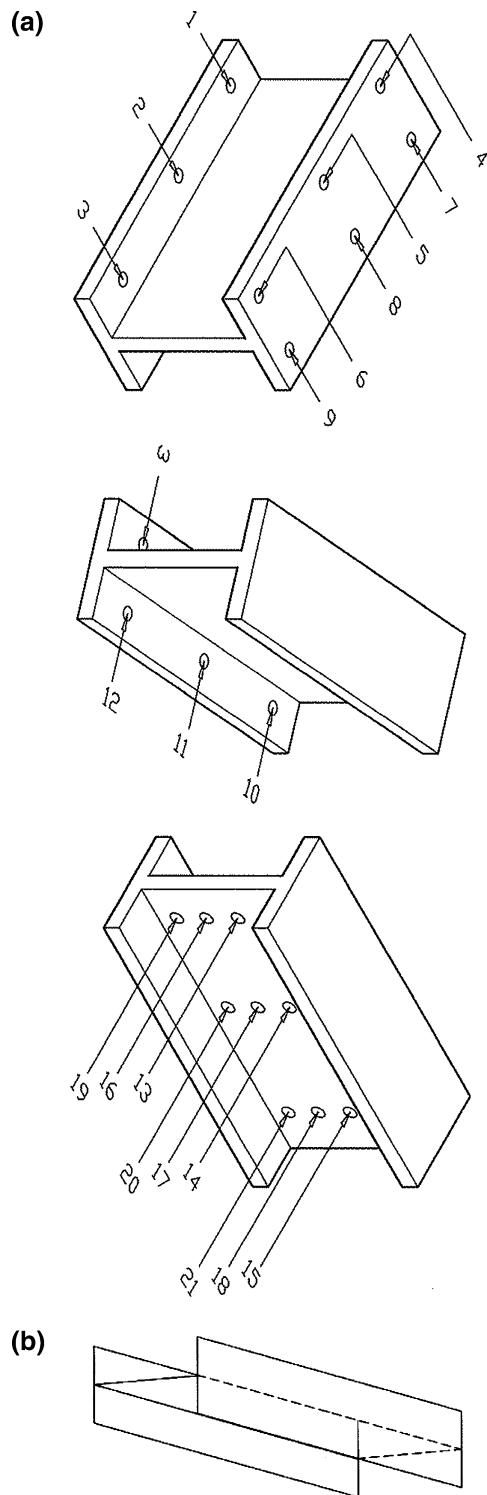

Fig. 2 I section profile in two configurations (a) and (b)

The heights of these points were measured along the depth of the web. Since it is not possible to place the L sections in a configuration similar to Fig. 2(b), accordingly the angle between the flange and the web was measured at three locations, A, B, C, 2.54 cm (1 in), from either edge and at the center.

The distortion for two samples is shown in Table 2. The difference between the pre-measure and re-measure values is in hundredths of an inch for water-quenched samples and in thousands of an inch for glycol quenched ones. The average angular distortion was greater than 5° in water and less than 2.5° in glycol.

3.1.3 Large Depth T Sections. For the large depth T sections, Fig. 4, points 1-3 and 7-9 are located on the inner part of the flange and 4-6 on top of the web depth along the length. Three angles A, B, C were also recorded. The distortion, Table 3 in glycol-quenched samples is slightly less than that in the water quenched ones. The average distortion was less than 6° in water and less than 4° in glycol.

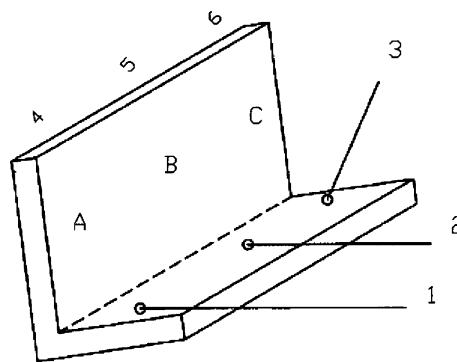

Fig. 3 Tall L-section profile

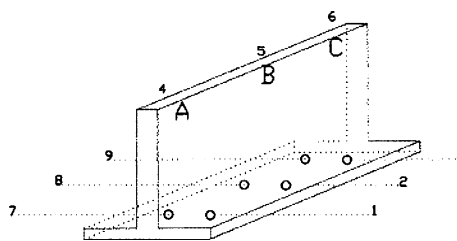

Fig. 4 Tall T-section profile

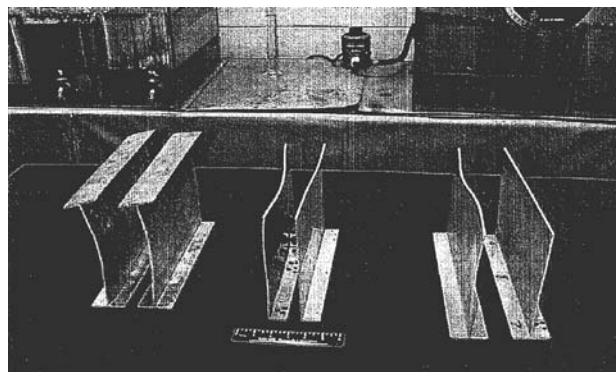

Fig. 5 A photograph of water quenched sections on the left side of each pair and glycol quenched on the right side

Table 2 The distortion in cms and in inches for water and glycol quenched large depth L sections

Quenchant	Point	Premeasure, in.	Premeasure, cm	Remeasure, in.	Remeasure, cm	Difference, in.	Difference, cm
<i>Water at 59 °F Sample 1*</i>							
	1	0.15459	0.3926586	0.15308	0.3888232	-0.00151	-0.0038354
	2	0.15142	0.3846068	0.13354	0.3391916	-0.01788	-0.0454152
	3	0.14980	0.380492	0.15939	0.4048506	0.00959	0.0243586
	4	6.85485	17.411319	6.85045	17.400143	-0.00440	-0.011176
	5	6.85727	17.4174658	6.84919	17.3969426	-0.00808	-0.0205232
	6	6.86108	17.4271432	6.83965	17.372711	-0.02143	-0.0544322
	A(°)	89.31098°		85.31082°		-4.00016°	
	B(°)	89.66091°		88.65220°		-1.00871°	
	C(°)	89.49681°		95.24684°		5.75003°	
<i>30% Polyalkylene Glycol at 59 °F Sample 1*</i>							
	1	0.13448	0.3415792	0.14055	0.356997	0.00607	0.0154178
	2	0.14062	0.3571748	0.13804	0.3506216	-0.00258	-0.0065532
	3	0.14658	0.3723132	0.13710	0.348234	-0.00948	-0.0240792
	4	6.85738	17.4177452	6.85267	17.4057818	-0.00471	-0.0119634
	5	6.85530	17.412462	6.84788	17.3936152	-0.00742	-0.0188468
	6	6.85432	17.4099728	6.84047	17.3747938	-0.01385	-0.035179
	A(°)	90.17744°		91.05474°		0.87730°	
	B(°)	89.85138°		89.73292°		-0.11846°	
	C(°)	90.16315°		87.61412°		-2.54903°	

* Note that the last 3 (A, B and C) are angles between the web and the flange.

Table 3 The distortion in cms and in inches for water and glycol quenched large depth T sections

Quenchant	Point	Premeasure, in.	Premeasure, cm	Remeasure, in.	Remeasure, cm	Difference, in.	Difference, cm
<i>Water at 59 °F Sample 1</i>							
	1	0.13180	0.334772	0.14120	0.358648	0.00940	0.023876
	2	0.13188	0.3349752	0.13861	0.3520694	0.00673	0.0170942
	3	0.13944	0.3541776	0.21440	0.544576	0.07496	0.1903984
	4	6.85472	17.4109888	6.84069	17.3753526	-0.01403	-0.0356362
	5	6.86348	17.4332392	6.87424	17.4605696	0.01076	0.0273304
	6	6.86997	17.4497238	6.88828	17.4962312	0.01831	0.0465074
	7	0.13246	0.3364484	0.14076	0.3575304	0.00830	0.021082
	8	0.13000	0.3302	0.18390	0.467106	0.05390	0.136906
	9	0.13472	0.3421888	0.13533	0.3437382	0.00061	0.0015494
	A(°)	90.01228		84.80136		-5.21092	
	B(°)	90.13925		95.27665		5.13740	
	C(°)	89.56570		90.56397		0.99827	
<i>30% Polyalkylene Glycol at 59 °F Sample 1</i>							
	1	0.12987	0.3298698	0.13248	0.3364992	0.00261	0.0066294
	2	0.12854	0.3264916	0.13581	0.3449574	0.00727	0.0184658
	3	0.13026	0.3308604	0.13141	0.3337814	0.00115	0.002921
	4	6.83452	17.3596808	6.82113	17.3256702	-0.01339	-0.0340106
	5	6.84977	17.3984158	6.84161	17.3776894	-0.00816	-0.0207264
	6	6.86318	17.4324772	6.86205	17.429607	-0.00113	-0.0028702
	7	0.13103	0.3328162	0.13597	0.3453638	0.00494	0.0125476
	8	0.13202	0.3353308	0.13381	0.3398774	0.00179	0.0045466
	9	0.13015	0.330581	0.13094	0.3325876	0.00079	0.0020066
	A(°)	89.65550		90.70589		1.05039	
	B(°)	89.88586		86.02633		-3.85953	
	C(°)	89.79032		88.65778		-1.13254	

3.1.4 Short Depth L and T Sections. For the short depth L and T sections, the web was half (9 cms or 3.5 inches) that of the large depth ones. In Tables 4 and 5 the same number of points was measured as in Tables 2 and 3. The distortion values were minimal (in thousandths of an inch) for both water and glycol quenched samples. Accordingly only one angle was measured between the web and flange and the distortion was almost always within one degree.

In the L and T sections the top part where the upper flange was removed experiences the most distortion, Fig. 1 and 5.

3.2 Summary of the Effects of Section Shape

The distortion of the glycol-quenched samples was less than that in water-quenched samples. For the same wall thickness, the I section had the most pronounced distortion along the Z direction followed by the large depth L and T sections. The flanges are 16% thicker than the walls, the I section has four times and two times more flange area as compared to the L and T sections.

Accordingly, there is more area of varying thickness in the I section as compared to the L and T section. Since warpage was

Table 4 The distortion in cms and in inches for water and glycol quenched short depth L sections

Quenchant	Point	Premeasure, in.	Premeasure, cm	Remeasure, in.	Remeasure, cm	Difference, in.	Difference, cm
<i>Water at 59 °F Sample 1</i>							
	1	0.13423	0.3409442	0.14177	0.3600958	0.00754	0.0191516
	2	0.13171	0.3345434	0.13814	0.3508756	0.00643	0.0163322
	3	0.13083	0.3323082	0.13887	0.3527298	0.00804	0.0204216
	4	3.50504	8.9028016	3.50122	8.8930988	-0.00382	-0.0097028
	5	3.50879	8.9123266	3.50859	8.9118186	-0.00020	-0.000508
	6	3.51451	8.9268554	3.50981	8.9149174	-0.00470	-0.011938
	Angle(°)	90.39710		89.64311		-0.75399	
<i>30% Polyalkylene Glycol at 59 °F Sample 1</i>							
	1	0.13199	0.3352546	0.13158	0.3342132	-0.00041	-0.0010414
	2	0.14321	0.3637534	0.14040	0.356616	-0.00281	-0.0071374
	3	0.14841	0.3769614	0.14598	0.3707892	-0.00243	-0.0061722
	4	3.50777	8.9097358	3.50076	8.8919304	-0.00701	-0.0178054
	5	3.51254	8.9218516	3.50732	8.9085928	-0.00522	-0.0132588
	6	3.51223	8.9210642	3.51090	8.917686	-0.00133	-0.0033782
	Angle(°)	89.74887		89.73433		-0.01454	

Table 5 The distortion in cms and in inches for water and glycol quenched short depth T sections

Quenchant	Point	Premeasure, in.	Premeasure, cm	Remeasure, in.	Remeasure, cm	Difference, in.	Difference, cm
<i>Water at 59 °F Sample 1</i>							
	1	0.13108	0.3329432	0.12937	0.3285998	-0.00171	-0.0043434
	2	0.13097	0.3326638	0.13169	0.3344926	0.00072	0.0018288
	3	0.13146	0.3339084	0.13058	0.3316732	-0.00088	-0.0022352
	4	0.13200	0.33528	0.12825	0.325755	-0.00375	-0.009525
	5	0.12996	0.3300984	0.12935	0.328549	-0.00061	-0.0015494
	6	0.13262	0.3368548	0.13094	0.3325876	-0.00168	-0.0042672
	7	3.48887	8.8617298	3.48277	8.8462358	-0.00610	-0.015494
	8	3.48792	8.8593168	3.48839	8.8605106	0.00047	0.0011938
	9	3.48775	8.858885	3.48787	8.8591898	0.00012	0.0003048
	Angle(°)	90.70199		90.36177		-0.34022	
<i>30% Polyalkylene Glycol at 59 °F Sample 1</i>							
	1	0.12895	0.327533	0.13507	0.3430778	0.00612	0.0155448
	2	0.12959	0.3291586	0.12882	0.3272028	-0.00077	-0.0019558
	3	0.13191	0.3350514	0.13023	0.3307842	-0.00168	-0.0042672
	4	0.13106	0.3328924	0.13296	0.3377184	0.00190	0.004826
	5	0.13014	0.3305556	0.12919	0.3281426	-0.00095	-0.002413
	6	0.13191	0.3350514	0.13056	0.3316224	-0.00135	-0.003429
	7	3.48685	8.856599	3.48905	8.862187	0.00220	0.005588
	8	3.48685	8.856599	3.48774	8.8588596	0.00089	0.0022606
	9	3.48706	8.8571324	3.48615	8.854821	-0.00091	-0.0023114
	Angle(°)	90.76914		90.93747		0.16833	

more visible in the web of the sections as opposed to the flange, the short depth L and T sections showed minimal distortion, both quenched in water or glycol.

4. Conclusions

The results of the study indicate that:

1. As expected, warpage is more significant with increasing severity of quench.
2. Along the web depth, warpage is more significant in I sections as compared to L and T sections. In the L and T sections the top part where the upper flange was removed experiences the most distortion.
3. Warpage increases with increased depth of the web.

Acknowledgment

This work was funded by the National Science Foundation, NSF Grant No. EEC-0353668, Research Experiences for the

Undergraduates (REU) site, Ms. Esther Bolding is the program manager. The authors wish to thank Mr. R. Marloth of the Mechanical Engineering Department of Loyola Marymount University for reviewing the manuscript and Ms. Maria Guerrero and Ms. Jacquelyn C. Davis for preparing the manuscript.

References

1. C.E. Bates, Selecting Quenchants to Maximize Tensile Properties and Minimize Distortion in Aluminum Parts, *J. Heating Treating*, 1987, 5(1), p 27–40
2. C.E. Bates and G.E. Totten, Procedure for Quenching Media Selection to Maximize Tensile Properties and Minimize Distortion in Aluminum Alloy Parts, *Heat Treatment of Metals*, 1988, 4, p 89–97
3. R. Torgerson and C. Kropp, Improving Heat Treat Processing of 7050 Aluminum Alloy Forging Using Synthetic Quenchants, *National SAMPE Symposium and Exhibition*, 1977, 22, p 111–132
4. B.S. Lasday, "Polyalkylene Glycol Quenching in Heat Treatment of Aluminum Alloy Parts Satisfies Strength Requirements While Limiting Distortion," *Industrial Heating*, Jul 1989, p 18–22
5. T.R. Croucher and M.D. Schuler, "Distortion Control of Aluminum Products using Synthetic Quenchants," *Metals Engineering Quarterly*, Aug 1991, P 14–18

6. J.T. Staley, Quench Factor Analysis of Aluminum Alloys, *Mater. Sci. Technol.*, 1987, **3**, p 923–935
7. UCON Quenchant A, Tenaxol, Incorporated, Brochure, 1973
8. “Quenchant Overcomes Distortion Problems,” *Metal Working Production*, Nov 1977, p 98–99
9. J.T. Staley, “Metallurgical Aspects Affecting Strength of Heat-Treatable Alloy Products Used in Aerospace Industry,” *The Third International Conference on Aluminum Alloys, EMAS*, 1986, p 107–143
10. J. Foyos, E.W. Lee, C. Kumor, M. Smith, C. Hou, and O.S. Es-Said, “Feasibility Study on the Warpage of 7050 Aluminum Plates,” *Light Weight Alloys for Aerospace Applications IV*, E.W. Lee, et al. Eds., TMS, 1997, p 73–83
11. G.P. Konyukov, A.S. Bedarev, G.I. Beloborodov, E.G. Ilyushko, V.V. Muraviv, and A.V. Sharko, “Effect of Quenching in New Media on the Properties and Structure of Aluminum Alloys,” *Metal Science and Heat Treatment*, **22**, translated from *Meallovendenie, Termicheskaya Obrabotka Metallov*, 10, Oct 1980, p 26–30
12. L. Maidment, S. Water, and G. Raul, “Heating Treatments for Avoiding Distortion of Aluminum Alloys and Microcracking of High Steel,” *Industrial Heating*, Mar 1985, p 32–34