

Journal of Physics Special Topics

A1_1 The Flat Earth's Escape Velocity

K. Flatt, M. Garreffa, W.H.A. Longman, S. Turnpenney

Department of Physics and Astronomy, University of Leicester. Leicester, LE1 7RH.

Oct 8, 2014.

Abstract

In some models, the Earth is considered to be a flat cylinder. Here we calculate the escape velocity for such a matter distribution and find that it is similar to the standard sphere. This result is briefly discussed and we show that, for large distances, the force from such a planet would tend to that from a sphere as expected.

Belief that the Earth is flat originates from ancient civilization, and persists to this day [1] due to a revival in the 19th century spearheaded by Samuel Rowbotham [2]. This idea is known as the Flat Earth and in this paper we derive an analytic expression for the hypothesised planets escape velocity that is, the minimum velocity required for a test mass to overcome the gravitational potential. In the model we propose, the Flat Earth is a disk of height h , radius R_E and total mass M_E , where the latter two parameters are the same as the radius and mass of the paradigmatic Spherical Earth model. The density ρ is considered constant throughout the mass distribution.

In a standard escape velocity treatment, the potential energy at a point on the surface of a spherical body is calculated: the escape velocity is then that which gives a high enough kinetic energy to overcome this potential. When such a method is tried outside of spherical symmetry, however, it leads to several problems: in particular it is not possible to solve analytically for the potential inside the cylinder. The method presented here thus considers Newtonian force-at-a-distance in place of energetics, in order to arrive at an analytic result.

We can consider the forces on a test particle of mass M at a point on the z -axis, at a distance λ from a ring of mass M_R . Using a cylindrical co-ordinate system, the force can be resolved into z and r components and from Fig. 1 it can be seen be clearly seen that components in the r direction will cancel so that the force is directed entirely along z . If a distance λ is defined as the total distance of the particle from the ring, as in the geometry of Fig. 1, the force on the particle is then

$$\vec{F} = -\frac{GM_R M}{\lambda^2} \hat{z} \quad (1)$$

where the minus sign comes from the fact that the particle is being drawn towards the centre of the ring. To extend this treatment to a disk we integrate the rings over a radius R_E . To do this, we write the

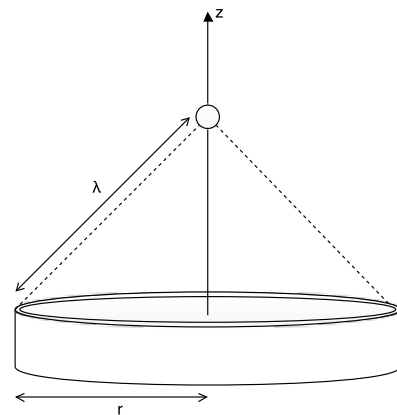

Fig. 1: This diagram shows a point mass at a height z above the centre of a ring, radius r , so that the total distance from the ring is $\lambda^2 = r^2 + z^2$. The gravitational force felt from this ring by the test particle will act along the dashed line: it can be seen by resolving this force that only the component along the z axis will take effect. In order to find the total force on an object due to a flat disk, we integrate a series of rings with radii between 0 and R_E . For more details on this, see the text.

mass of the ring as a radius element in terms of the density ρ , which we consider constant. This gives $M_R = 2\pi\rho h r dr$. We also eliminate λ to give, for a ‘force element’

$$d\vec{F} = -2\pi G h M \rho \frac{r}{z^2 + r^2} dr \hat{z}. \quad (2)$$

We wish to find the force from the whole Earth by integrating between $r = 0$ and $r = R_E$. Firstly, from this point on the vector notation is dropped for simplicity. However it should be noted that this equation is only valid along the z -axis; and that the force is directed along this axis towards the centre. By making the substitution $q = r/z$ this can be written as

$$F = -2\pi G h M \rho \int \frac{q}{1 + q^2} dq, \quad (3)$$

The integral over q is a standard integral that can be found in standard reference texts [3]. It is given by

$$\int \frac{x}{1+x^2} dx = \frac{1}{2} \ln(1+x^2) + C, \quad (4)$$

with C the arbitrary constant of integration. Substituting this into Eq. 3 and applying the boundary conditions, the equation for the force on our particle becomes

$$F = -\pi GhM\rho \ln\left(1 + \left(\frac{R_E}{z}\right)^2\right). \quad (5)$$

Before continuing, we should briefly consider whether this result is reasonable. One way to do this is to see how this function behaves for large distances from the Flat Earth. In order to this, we can expand the logarithm in ascending powers of $\frac{R_E}{z}$. Such an expansion is given by

$$\ln(1+x^2) \approx x^2 - \frac{x^4}{2}. \quad (6)$$

For the current discussion, $x = R_E/z$. Thus $R_E/z \ll 1$ for large z and we can ignore the terms higher order than squared and use this approximation for the long range limit of the force, Eq. 5. If the definition of the mass in terms of the density and volume is included, we find

$$F = -\frac{GM_E M}{z^2}. \quad (7)$$

Thus at long distances the gravitational field of the Flat Earth approaches that of a point mass, as to be expected. We can then see that the result derived so far is correct, and can now solve for the escape velocity. The procedure we use for this is fairly straightforward - Newton's second law can be written in the form

$$F = mv \frac{dv}{dz} \quad (8)$$

by application of the chain rule. This is then equated with the earlier expression for the force at a point, Eq. 5, and we solve according to a set of boundary conditions. For this we note that the definition of the escape velocity is the *minimum* initial velocity for a test mass to be able to travel away from a body without its direction being reversed - hence it will have velocity of $v = 0$ as $z \rightarrow \infty$ and a velocity of $v = v_F$ at $z = 0$. We hence have to solve

$$\int_{v_F}^0 v dv = -\pi Gh\rho \int_{\infty}^0 \ln\left(1 + \left(\frac{R_E}{z}\right)^2\right) dz. \quad (9)$$

By using the substitution $x = R_E/z$ this can be rewritten in the form

$$\int_{v_F}^0 v dv = \pi Gh\rho R_E \int_{\infty}^0 \frac{\ln(1+x^2)}{x^2} dx. \quad (10)$$

Again, the right hand is a standard integral which gives the result [5]

$$\int_0^{\infty} \frac{\ln(1+x^2)}{x^2} dx = \pi. \quad (11)$$

Finally, we can rearrange the results so far to give an expression for the Flat Earth's escape velocity. Also using the definition of the mass in terms of density and volume, i.e. $M_E = \pi R_E^2 h \rho$, we can eliminate the density as a parameter. The result of doing this is:

$$v_F = \sqrt{\pi} \sqrt{\frac{2GM_E}{R_E}} = \sqrt{\pi} v_s, \quad (12)$$

where $v_s = \sqrt{2GM_E/R_E}$ is the usual result for the escape velocity of a spherical matter distribution - i.e. the Earth [6]. So, interestingly, it can be seen that changing the particular shape of the mass distribution simply introduces an extra factor of $\sqrt{\pi}$ into the final result. In some respects this is to be expected, as the behaviour of the gravitational field will simply be that of a point mass far away from both matter distributions. Numerically, using the standard values for the various parameters gives a value of $v_F = 19.9 \text{ kms}^{-1}$.

So, to conclude, we have calculated an expression for the escape velocity of a cylindrical mass distribution - i.e. the Flat Earth - and found that it is similar in form to that of a spherical distribution. This suggests an obvious area for further research: what happens for other mass distributions? For example, it may be possible to derive expressions for the escape velocity of a Cube Earth or Rod Earth. Could these also be classified similarly by an extra factor? Sticking to the conceptual difficulties surrounding the Flat Earth, it would be interesting to further explore claims made by the Flat Earth Society in the context of mathematical physics or experimental tests.

References

- [1] <http://theflatearthsociety.org/cms/>, accessed: 08/10/2014
- [2] Samuel Rowbotham, *Astronomy: Earth Not a Globe*, Forgotten Books, 2007
- [3] <http://www.wolframalpha.com/input/?i=int+x%2F%281%2Bx^2%29+dx>, accessed: 07/10/2014
- [4] <http://www.wolframalpha.com/input/?i=taylor+expand+log%28x^2%2B1%29>, accessed: 07/10/2014
- [5] <http://www.wolframalpha.com/input/?i=integrate+log%28x^2+%2B+1%29%2Fx^2+between+0+and+infinity>, accessed: 07/10/2014
- [6] Tipler and Mosca, *Physics for Scientists and Engineers 6th Edition*, W.H Freeman, 2007