



Citation for published version:

Gu, C, Tang, C, Xiang, Y & Xie, D 2019, 'Power-to-gas management using robust optimisation in integrated energy systems', *Applied Energy*, vol. 236, pp. 681-689. <https://doi.org/10.1016/j.apenergy.2018.12.028>

DOI:

[10.1016/j.apenergy.2018.12.028](https://doi.org/10.1016/j.apenergy.2018.12.028)

Publication date:

2019

Document Version

Peer reviewed version

[Link to publication](#)

Publisher Rights

CC BY-NC-ND

University of Bath

General rights

Copyright and moral rights for the publications made accessible in the public portal are retained by the authors and/or other copyright owners and it is a condition of accessing publications that users recognise and abide by the legal requirements associated with these rights.

Take down policy

If you believe that this document breaches copyright please contact us providing details, and we will remove access to the work immediately and investigate your claim.

Power-to-Gas Management using Robust Optimisation in Integrated Energy Systems

Chenghong Gu^a, Can Tang^a, Yue Xiang^b, and Da Xie^c

a: Dept. of Electronic and Electrical Eng., University of Bath, Bath, BA2 7AY, UK

b: College of Electrical Engineering and Information Technology, Sichuan University, Chengdu, China

c: Dept. of Electronic and Electrical Eng., Shanghai Jiao Tong University, Shanghai, China

Abstract — A large volume of wind power is curtailed worldwide due to the intermittency and limited transportation capacity of electrical power systems. New technologies, Power-to-Gas via electrolysis, can convert excessive wind power into hydrogen to be transported by natural gas systems. However, the injection of H₂ into natural gas pipelines can cause gas quality issues due to changing gas compositions.

This paper investigates the impact of injecting H₂ converted from wind power on natural gas quality. Two key indexes used to measure gas quality, Wobbe Index and Combustion Potential, are introduced to examine the impact. Then, in order to bring the two indexes into acceptable statutory ranges, H₂ is mixed with Liquid Petroleum Gas and Nitrogen. A robust optimization model, considering wind power uncertainties, is thereafter developed to manage the gas mixture, maximize H₂ injection. This paper uses the dynamic gas system model to represent real-time pipeline flows, which can better reflect gas flow features over time. The proposed method is demonstrated on a small integrated gas-electricity system. Results illustrate that excessive H₂ injection will reduce Wobbe Index but increase Combustion Potential. The robust optimization approach can effectively manage the mixture while ensuring gas quality with an uncertain wind power supply. The proposed method is beneficial to reducing renewable energy curtailment and maximizing H₂ injection, benefiting electricity system operators with low operation costs and wind power more penetration.

Keywords—Integrated-energy System, Wind Power, Hydrogen (H₂), Wobbe Index, Combustion Potential, Robust Optimisation

1 INTRODUCTION

Decarbonizing the energy sector is a key objective in many countries, where one essential way is to increase the penetration of renewable into the electrical systems. However, a large volume of renewable energy is curtailed during rich wind and solar resource periods due to the limited transfer capacity of electricity systems. For example, the aggregated wind power curtailment in China was 32.3 billion kWh during the first 7 months of 2016 according to the data from its National Energy Administration. This huge volume of renewable energy curtailment has inspired new technologies to reduce the waste. One such promising approach is to convert the excessive renewable into hydrogen (H₂), so that it can be transported via natural gas systems [1]. This Power-to-Gas (PtG) technology together with electricity systems can form multi-energy systems, which have been demonstrated in many countries. Although it is very promising, there are many technical challenges in injecting the produced H₂ into natural gas systems [2]. Authors in [3] systematically analyze the role of PtG in the UK integrated energy systems.

Some existing work has explored the production of H₂ by using wind power and the coupled operation with wind farms. Paper [4] presents a mathematical formulation to model and evaluate natural gas pipeline networks under H₂ injection, with the objective to minimize the classical fuel problems in compressor stations. In paper [5], a new coordination control scheme for the combined offshore wind farms and H₂ management system is proposed to reduce the adverse impact of wind intermittency. A supercapacitor bank is supplemented to the system to provide short-term transient compensation. Paper [6] studies the coupled operation of electrolyzers and wind turbines, where four different electrolyzer models are evaluated. These models are aggregated to a variable speed wind turbine model by MATLAB. In paper [7], a method for operating a hybrid plant with wind power and H₂ storage is presented. The H₂ produced by electrolysis is used for stationary fuel cells to generate electricity. Paper [8] proposes a reconfigurable testbed to integrate various energy resources, including electricity, H₂ and thermal energy.

Some studies have further investigated the interaction between natural gas and electricity systems by including PtG technology that produces H₂. Paper [9] studies H₂ from PtG facilities supplied to a gas grid to maximize the expected profits of PtG facilities without causing overloading in the electricity system. Paper [10] uses a dynamic system model to trace the impact of injecting H₂ into natural gas systems. It develops a model to simulate the unsteady operation of a portion of the gas grid and an energy-based approach is designed to include the variable gas compositions along the pipe. However, it only passively analyses the impact but no proactive actions are proposed to remove any adverse impact on gas quality. Paper [11] designs a security-constrained bi-level economic dispatch model to operate the integrated natural gas and electricity systems. The wind power and PtG process are also included. Similarly, authors in [12] propose an economic dispatch model for electricity and natural gas systems, where carbon capture and PtG are considered. However, the focus of the two paper is on the integrated system dispatch, but H₂ blending impact on gas quality is not studied. In paper [13], the authors study the electrical and economic performance of PtG technologies at distribution networks, and it concludes that the profitability is highly dependent on the power surplus in the grid and loading hours of electrolyzers.

When H₂ is injected into the natural gas system, the gas composition will be dramatically changed. The gas mix in pipelines affects not only the security of pipelines but also gas quality to end customers, adversely impacting gas-fired appliances or resulting in emergency shutdowns. In addition, the changed compositions will also alter the original traveling features of the mixed gases, decided by ambient temperature, gas pressures and materials of pipelines, etc. Therefore, the quality of delivered gas with H₂ has to satisfy certain statutory standards in order to ensure combustion characteristics. In the literature, paper [14] develops a steady-state method to investigate the impact of injecting alternative gases into natural gas systems. Results show that carbon emissions can be effectively reduced if appropriately managing diversified gas supply sources is adopted. Paper [15] studies natural gas, liquid, and new alternative fuels for gas turbines and explains the interrelationships between fuel system design, fuel properties, and gas turbine operability. Paper [16] analyzes the performance of IT-SOFC/GT hybrid system by using different gasified biomass as fuel. According to the outcome, it studies the impact of fuel types on system component operation characteristics so that optimal adjustment can be adopted to make them more adaptable. In [17], the authors design a novel IT-SOFC/GT hybrid system fueled by gasified biomass gas by using a new approach to determine the safe

operation zone for the hybrid system. The obtained characteristic map of safe operation zone of the hybrid system can be used to endure safety by using various biogases as fuel.

In order to measure the quality of gases delivered to end customers, two key parameters are usually used: i) the Wobbe Index that measures the energy output of gases during combustion, and ii) the Combustion Potential that measures the gas combustion stability. Due to the increasingly diversified gas supplies, variations in gas quality can be potentially problematic to appliances, e.g. a rate change in Wobbe Index of 1%/minute has caused issues for one E.ON generator [16]. Thus, it is essential to study this problem by using dynamic models, particularly, at local gas distribution systems which have no compressor stations to operate system pressures. Paper [14] studies gas quality by using a static model, where Heat Value and Wobbe Index are considered, but the model cannot trace gas quality change over time. Authors in [17] extensively investigate the impact of blending H₂ on the performance of domestic appliances. It highlights that the Wobbe Index related to thermal output and flashback for safety issues are the two key constraints should be carefully considered. Paper [18] focuses on the constraints imposed by the phenomena of flash-back and blow-off with the injection of H₂ converted from renewable energy. By using the Wobbe Index, the authors discuss the relationship between molar hydrogen percentage and annual carbon dioxide output, and predict the effect of hydrogen-enrichment on fuel costs.

To summarise, existing research mainly focuses on assessing the impact of gas quality from blending alternative gases on the performance of gas-fired equipment but ignores the traveling characteristics of the mixed gases within pipelines. Some research such as [19] studies security-constrained joint expansion planning for the combined natural gas and electricity systems. The work generally analyses the adverse impact due to blending alternative gases into the natural gas system in a passive way but no actively optimal management strategies are designed to reduce the impact. Practically, if alternative gases are mixed with natural gas and injected into gas systems, gas compositions will fundamentally change varying over locations and time, which can have an adverse impact and heat value and combustion stability. From this aspect, the proper management of H₂ injection into the natural gas system is key to ensure mixed gas quality.

This paper studies the impact of injecting H₂ from excessive wind power into natural gas networks based on the dynamic gas system model. Two key indexes to measure gas interchangeability with H₂ injection, Wobbe Index and Combustion Potential, are extensively quantified to measure gas quality change. In order to increase the injection level of H₂, it is mixed with Liquid Petroleum Gas (LPG) and Nitrogen (N₂) to ensure gas quality, maintaining both Wobbe Index and Combustion Potential within standard statutory ranges. Then, a robust optimal formulation is proposed to help manage the mix to maximize H₂ injection with the constraints of the Wobbe Index, Combustion Potential, and gas pressures. The proposed model is demonstrated on an integrated natural gas and electricity system, linked by an electrolyser. Results show that the model is effective in analysing the dynamic couplings of gas-electricity networks and managing H₂ injection with constraints satisfied. The management framework can be easily extended to be used in blending other alternative gases into the natural gas system, such as replacement gas or additive gas, considering that fuel variability will be more common in the future.

The main contribution of the paper is: i) it studies the impact of injecting of H₂ produced from excessive wind power via electrolysis into natural gas systems on gas quality. The dynamic natural gas system model is utilised to better reflect the traveling characteristics of mixed gas flows within the gas pipelines. Compared

to some existing research that uses static natural gas system models, the dynamic models can produce more accurate results, which reflect both spatial and temporal features of gas composition; ii) it introduces two important indexes, Wobbe Index and Combustion Potential, to measure the gas interchangeability and examine the impact of blending H₂ into the gas systems on gas combustion stability. Compared to only using heat value to measure gas quality change, the two indexes can more completely reflect gas quality change due to H₂ injection, measuring not only heat value but also combustion potential of mixed gases with H₂; iii) it develops a robust optimisation based strategy to manage the blending of H₂ with other gases considering uncertain wind output so as to maximise the injection with gas quality constraints satisfied. Compared to deterministic or stochastic optimisation strategies, the new management can incorporate H₂ injection uncertainty due to wind power intermittency and design blending strategies can work even in the worst case of uncertainties.

2 POWER TO GAS

Electrolysers work by splitting the water molecule into H₂ and oxygen (O₂) by using electricity. Excessive wind power can be converted into H₂ through electrolysis and then injected into natural gas networks to transport. In normal operating modes, electrolysis efficiency linearly decreases with power input as electrical resistance is the dominating loss factor [7]. Thus, the relationship between electricity supply and produced H₂ can be fitted to a linear curve by assuming a constant efficiency. In this study, a constant efficient rate is used and thus H₂ production is

$$\dot{V}_e = \eta_e \cdot \frac{P_e}{HHV} \quad (1)$$

Where, P_e is the power consumed by the electrolyzer, η_e is its electrical efficiency, and HHV is the higher heat value of H₂, 3.509 kWh/m³.

3 GAS INTERCHANGEABILITY

This section explains the interchangeability of various gases and introduces two key indexes to measure gas interchangeability.

3.1 Gas Adaptability and Interchangeability

Interchangeability and adaptability are two key factors in examining the impact of gas composition change on end gas-fired appliances. When gas composition varies within a certain range and gas-fired appliances are still able to work, this is the gas that appliances have the ability to adapt to, called gas with adaptability. Two gases are interchangeable if they can ensure gas appliances to work properly, in terms of: i) meeting the original design settings without any adjustment; and ii) producing similar heat load, steady flame; iii) burning completely and having reliable ignition. Otherwise, they are not interchangeable and cannot replace each other in practice.

Some interchangeability measures have been designed, mainly from the historic evolution of downstream equipment population and characteristics of locally sourced gases. Key parameters introduced to measure gas interchangeability include the Wobbe Index, Combustion Potential, Heat Value, etc. In Europe, constraints on the Wobbe Index and inert gases are considered to be sufficient for ensuring wholesale gas quality [20]. However, the UK considers parameters related to the non-optimum performance of gas-fired

appliances such as Lift Index, Incomplete Combustion Factor and Soot Index. Table I provides some major gas-fired quality issues for different appliances. As seen, the Wobbe Index is a key parameter and other parameters vary for different appliances, particularly domestic burners and engines which are very sensitive to gas quality. In this study, Wobbe Index and Combustion Potential are used in injecting H₂ into natural gas systems.

TABLE I
GAS QUALITY ISSUES FOR DIFFERENT APPLIANCES [20]

	Concerns	Control parameter	Sensitivity to quality
Domestic burner	Significant appliance population without in-built pressure regulation or sophisticated controls	Wobbe index	High
Commercial and industrial burner	A wide range of use Efficiency Emission	Wobbe index Calorific value	Low-medium
Gas turbine	Efficiency Emissions Turbine life	Wobbe index Calorific value Gas index Fuel index	Low-high
Engine	Knock Efficiency emissions Stable combustion	Wobbe index Methane number Octane rating	High

3.2 Wobbe Index

In practice, two gases might have different calorific value and density. However, as long as they have equal Wobbe Indexes, the same burning appliances can obtain the same heat load under the same gas pressure. Domestic and commercial appliances are usually tuned to accept gases with a relatively small range of Wobbe Index. Industrial combustion applications are also similarly sensitive to gas quality changes. The Wobbe Index is

$$W = \frac{Q + (Q_{h,H} - Q_{h,g})\varphi_H}{\sqrt{\frac{\rho_g + (\rho_H - \rho_g)\varphi_H}{\rho_a}}} \quad (2)$$

Where, W is Wobbe index, $Q_{h,g}$ is the high heat value of the mixed gas, $Q_{h,H}$ is the high heat value of H₂, φ_H is the percent of H₂ in the gas (in volume), ρ_g is gas density, ρ_H is H₂ density, and ρ_a is air density.

Wobbe Index normally is acceptable with $\pm 5\% \sim 10\%$ of the standard setting and this range varies for different countries. For example, gas turbines are typically tuned to work within $\pm 5\%$ of the Wobbe Index setpoint. Outside of this range, non-optimised combustion can lead to inefficiencies, instabilities, and dangerous levels of carbon monoxide production. For manufacturing processes that rely on heat input, for example glass and ceramic production, product quality can be seriously affected by the gas quality change, particularly when heating is controlled by the volume of gas burned rather than energy throughput [20].

3.3 Combustion Potential

Combustion Potential, also called combustion gas combustion velocity, is a parameter to measure the combustion stability of gases. It is to reflect the combustion characteristics of gases, including produced combustion flame, yellow flame, tempering, and incomplete combustion tendency parameters. If two gases are interchangeable, their Combustion Potential values should be very close. The index is defined as

$$C_p = K_1 \frac{\varphi_H + 0.6(\varphi_{CO} + \varphi_{CH}) + 0.3\varphi_{MET}}{\sqrt{d}} \quad (3)$$

Where, C_p is combustion potential, K_1 is O₂ index, φ_{CO} is CO volume, φ_{CH} is the volume of hydrocarbon except methane, φ_{MET} is the methane volume, and d is the relative air density of the mixed gas.

4 DYNAMIC MODEL OF NATURAL GAS FLOW

This section uses a dynamic model to examine the characteristics of natural gas flows in pipelines due to H₂ injection. Temperature variations and pipe inclinations are neglected as they slightly change in low-pressure gas pipeline networks. For a pipeline with the length of L , its flow is governed by a series of Partial Differential Equations (PDEs) on spatial dimension $x \in [0, L]$ and time dimension t [21, 22].

The continuity governing equation is

$$\partial_t \pi + \frac{c^2}{A} \partial_x \dot{m} = 0 \quad (4)$$

Where, π is pressure (Pa), \dot{m} is mass flow (kg/s), and A is the cross-section area of the pipeline (m²).

The momentum equation is

$$\partial_t \dot{m} + \frac{c^2}{A} \partial_x \left(\frac{\dot{m}^2}{\pi} \right) + A \cdot \partial_x \pi + \frac{f c^2 \dot{m} |\dot{m}|}{2DA\pi} = 0 \quad (5)$$

Where, D is the diameter of the pipeline, f is its friction factor, and c is constant sound speed

$$c = \sqrt{ZRT} \quad (6)$$

Where, Z is compressibility factor, R is gas constant, and T is the temperature.

Because gas flow velocity is normally very small compared to sound speed, gas inertia term $\partial_t \dot{m}$ and convective inertia term $\partial_x (\dot{m}^2/\pi)$ in (5) can be neglected [23, 24]. Thus, only friction loss term $\partial_x \pi$ is considered in the momentum equation.

The solutions to the dynamic model in (4)-(6) on $t \in [0, \tau]$ and $x \in [0, L]$ require initial and boundary conditions [25], which are

$$\forall x \in [0, L]: \dot{m}(0; x) = \dot{m}_0(x), \quad (7)$$

$$\forall t \in [0, \tau]: \dot{m}(t; 0) = \dot{m}_{in}(t), \dot{m}(t; L) = \dot{m}_{out}(t). \quad (8)$$

$$\pi(0; 0) = \pi_0 \quad (9)$$

Where, \dot{m}_0 is the initial mass flow in the pipeline, \dot{m}_{in} and \dot{m}_{out} are the injections at the inlet and outlet end, and π_0 is the initial pressure at the beginning of the pipeline.

The dynamic model can be resolved by approaches, such as Finite Element Analysis (FEA). This paper resolves the dynamic models by the approach in [25]. In terms of compositions, natural gas contains many gas elements, such as methane, ethane, and propane. Each fluid in a pipe is defined either by its base qualities

or gas compositions. When tracking gas quality in pipes, the properties of various gas mixtures flowing throughout the whole system should be tracked and quantified as the mixtures decide the final gas quality. In meshed gas systems, pipelines, gas load, and gas supply are connected by mixing points and junctions, where different gases mix there. At these points, the base qualities of gases entering the points are quantified by using a molar-averaged mixing rule. Therefore, it is possible to calculate the quality of mixed gas at mixing points and junctions.

5 ELECTRICITY NETWORK MODELLING AND FLOWCHART

The section introduces the modelling of electricity networks and wind power in the integrated system.

5.1 Electricity Network Modelling

Because electricity flow travels at an extremely high speed compared to natural gas, electricity systems would have already entered steady states when natural gas networks are still undergoing dynamics. Therefore, the electricity network can be modelled in a static manner for the integrated system study. Assuming the voltage at node k is V_k and the angle is θ_i , the nodal active and reactive power P_i and Q_i are

$$P_k = V_k \sum_{m=1}^n (G_{km} V_m \cos \theta_{km} + B_{km} V_m \sin \theta_{km}) \quad (10)$$

$$Q_k = V_k \sum_{m=1}^n (G_{km} V_m \sin \theta_{km} - B_{km} V_m \cos \theta_{km}) \quad (11)$$

$$P_{ij} = V_{ij}^2 G_{ij} - V_i V_j (G_{ij} \cos \theta_{ij} + B_{ij} \sin \theta_{ij}) \quad (12)$$

By running load flow analysis, branch flows in (12) and system overloading can be quantified. Nodal generation curtailment is then conducted to resolve the overloading, achieved by: i) examining the branch violated thermal limits; ii) curtailing wind power generation based on their impact on the overload branches with Power Transfer Distribution Factors PTDF matrix [26].

5.2 Wind Power Modelling

Fig. 1 provides a typical wind power output curve under various wind speed. For simplicity, the impact of air density, swipe area of wind turbines, pressure, etc. are not considered in details. Supposing a wind turbine with a rated capacity of P_r , its actual output in response to each wind speed can be obtained by using (2) [27] under healthy conditions. If the wind turbine is unhealthy, the power output is zero.

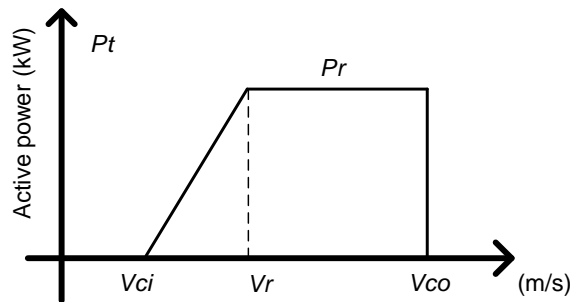

Fig.1. Typical wind turbine power curve.

The output of a wind turbine is given as follows

$$P_e = \begin{cases} 0, & 0 < v < V_{ci} \\ (a + b \cdot v + c \cdot v^2) \cdot P_r, & V_{ci} < v < V_r \\ P_r, & V_r < v < V_{co} \\ 0, & v > V_{co} \end{cases} \quad (13)$$

Where, P_e is wind turbine output, V_{ci} is wind cut-in speed, V_{co} is cut-out speed, V_r is rated output speed, P_r is rated output, and v is actual wind speed. a , b and c are coefficients.

Because wind power fluctuates, thus the generated H_2 also varies over time. As the focus of the paper is to examine the impact of injecting H_2 on gas pipelines and final gas quality, it assumes that all excessive wind power can be converted into H_2 and transported by natural gas systems.

6 OPTIMAL MANAGEMENT OF H_2 INJECTION

6.1 Optimisation Formulation

In reality, it is impossible to inject excessive H_2 from wind power into the natural gas system due to its low Wobbe Index and high Combustion Potential. One mitigation solution is to mix H_2 with other gases that have high Wobbe Index and low Combustion Potential. In this way, it will bring the two indexes back into an acceptable statutory range to meet security and quality standards. Thus, an optimal approach for managing H_2 penetration is essential, which is developed in this paper. The objective is to minimise Liquid Petroleum Gas (LPG) percentage by mixing it with H_2 and N_2 at a supply point.

In practice, the volume of produced H_2 is uncertain due to the intermittency of wind power and thus, traditional deterministic optimisation is not applicable. If the impact of the uncertainty is not considered, the optimization objective may be heavily affected, resulting in optimization plans to deviate from the expected goals. Thus, a robust optimization methodology is designed here to optimally manage the mixture of LPG, H_2 , and N_2 for dealing with the uncertainty of H_2 production. The general robust optimization problem is described as

$$\begin{aligned} & \min \sup f_0(x, \xi) \\ & \text{s. t. } f_i(x, \xi) \leq 0, \forall \xi \in U, (i = 1, \dots, m), x \in X \end{aligned} \quad (14)$$

The core to solve the robust optimization (14) is to transform it into a solvable robust counterpart. In the optimal formulation, it is assumed that the amount of LPG is x_2 in volume in the mixture, because LPG is costly to buy but N_2 is relatively cheap. Thus, the optimization objective becomes

$$\text{Objective: } \min\{x_2\}, \forall x_{H_2} \in U \quad (15)$$

where, U indicate the uncertainty set of x_{H_2} .

The following two equations define the changes of Wobbe Index and Combustion Potential due to the penetration of H_2 , when it is mixed with LPG and N_2

$$W = \frac{Q_{H_2} \cdot x_{H_2} + Q_2 \cdot x_2 + Q_3 \cdot x_3}{\sqrt{(\rho_{H_2} \cdot x_{H_2} + \rho_2 \cdot x_2 + \rho_3 \cdot x_3)(x_{H_2} + x_2 + x_3)}} \quad (16)$$

$$C_p = K_1 \frac{E_{H_2} \cdot x_{H_2} + E_2 \cdot x_2 + E_3 \cdot x_3}{\sqrt{(\rho_{H_2} \cdot x_{H_2} + \rho_2 \cdot x_2 + \rho_3 \cdot x_3)(x_{H_2} + x_2 + x_3)}} \quad (17)$$

Where, x_2 and x_3 are the volumes of LPG and N_2 , Q_{H_2} , Q_2 , and Q_3 are the heat values of H_2 , LPG and N_2 , E_{H_2} , E_2 and E_3 are their Combustion Potential indexes respectively.

There are three groups of constraints for this optimisation:

Gas quality:

- Wobbe index within a certain range

- Combustion Potential within a certain range
- H₂ volume relative to gas demand within a certain range

Pipeline security:

- The maximum percentage of H₂ in the mixed gas at the injected site is set at 40% for security reason

Composition:

- Percentage of all gases within a certain range
- The total percentage of all gases is 100%

All constraints are modelled in (18)

$$\text{s. t. : } \begin{cases} W_L \leq W \leq W_U \\ C_{p,L} \leq C_p \leq C_{p,U} \\ \frac{x_{H_2}}{x_{H_2} + x_2 + x_3} \ll 0.4 \\ \mathbb{U} = \{x_{H_2} = x_{H_2}^0 + \sum_{i=1}^L \zeta_i x_{H_2}^i\} \end{cases} \quad \forall x_{H_2} \in \mathbb{U} \quad (18)$$

Where, x_2 and x_3 are the volumes of LPG and N₂. L, U indicate the low and upper boundaries of the variables. ζ is the perturbation vector, which meets $-1 \leq \zeta \leq 1$. $x_{H_2}^i$ is the basic shifts.

To generate the robust counterpart, the constraints should be converted into tractable representation. Take $W_L \leq W$ as an example.

$$W_L \leq \frac{Q_{H_2} \cdot x_{H_2} + Q_2 \cdot x_2 + Q_3 \cdot x_3}{\sqrt{(\rho_{H_2} \cdot x_{H_2} + \rho_2 \cdot x_2 + \rho_3 \cdot x_3)(x_{H_2} + x_2 + x_3)}} \quad (19)$$

Then,

$$W_L^2 \leq \frac{(Q_{H_2} \cdot x_{H_2} + Q_2 \cdot x_2 + Q_3 \cdot x_3)^2}{(\rho_{H_2} \cdot x_{H_2} + \rho_2 \cdot x_2 + \rho_3 \cdot x_3)(x_{H_2} + x_2 + x_3)} \quad (20)$$

$$W_L^2 (\rho_{H_2} \cdot x_{H_2} + \rho_2 \cdot x_2 + \rho_3 \cdot x_3)(x_{H_2} + x_2 + x_3) \leq (Q_{H_2} \cdot x_{H_2} + Q_2 \cdot x_2 + Q_3 \cdot x_3)^2 \quad (21)$$

Finally, this constraint can be converted into

$$a(x_{H_2} + b)^2 + c \leq g(x_2, x_3), \quad a, b, c \in \mathbb{R}, \forall x_{H_2} \in \mathbb{U} \quad (22)$$

Thus, the tractable representation of (20) is

$$\max(a(x_{H_2} + b)^2 + c) : \text{s. t. } x_{H_2} \in \mathbb{U} \leq g(x_2, x_3) \quad (23)$$

6.2 Implementation Flowchart

The flowchart of the proposed framework is summarised in Fig.2. There are two layers: i) the upper layer is the operation of the electricity network to identify system overloading, and ii) the lower layer conducts gas system dynamic analysis with H₂ injection. If the gas quality is not met with H₂ injection, a robust optimal management is conducted to mix H₂ with LPG and N₂ to bring the Wobbe Index and Combustion Potential back into the acceptable statutory ranges.

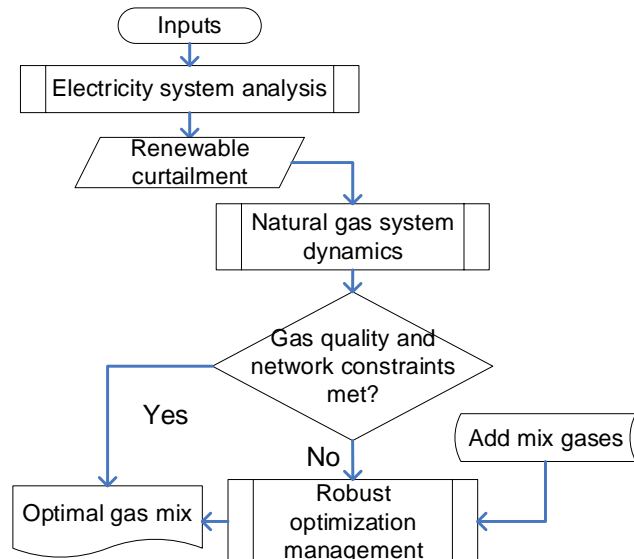

Fig.2. Implementation flowchart of the proposed management strategy

7 CASE STUDIES

In this section, the proposed models are demonstrated on an integrated gas and electricity network given in figure 3. Three cases are studied to assess the impact of H₂ injection and optimal management on gas quality: i) case 1- without any H₂ injection; ii) case 2- with H₂ injection but no gas mixture adopted; and iii) case 3 - H₂ injection with optimal gas mixture management.

7.1 Demonstration Inputs

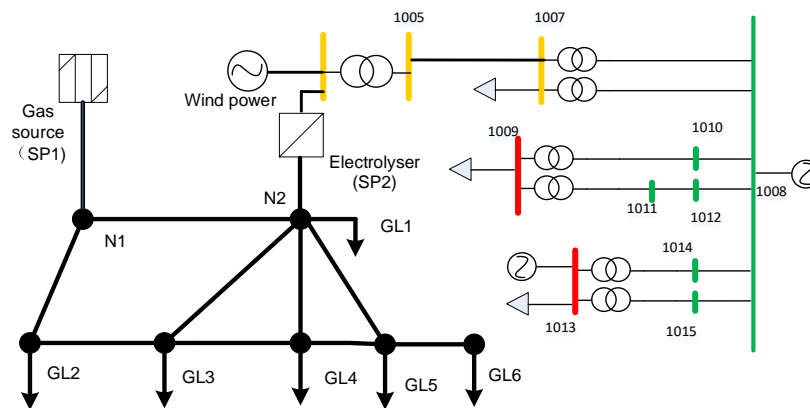

Fig. 3. The test integrated energy system.

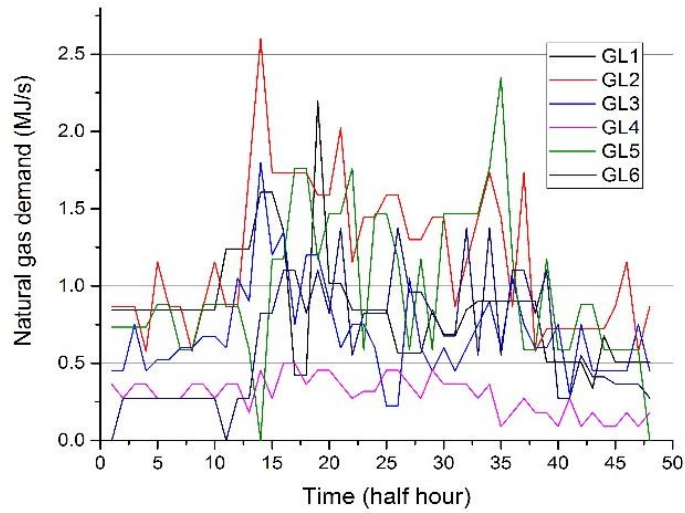

Fig.4. Gas demand over time.

The gas network is connected to the main gas supply network at Node 1, whose pressure is set at 75 barg. Node N₂ is connected to the electricity network via an electrolyser. The diameter, wall thickness, and roughness, drag factor, and efficiency of all pipes are assumed to be: 016m, 12.7mm, 25.4 micron, 0.96 and, 1 respectively. The lengths of all gas pipes are given in Table II.

The gas demand profiles over 24 hours are plotted in Fig. 4. Overall, GL2 has the highest peak, over 2.5 MJ/s, during the morning, and GL5 has the highest peak of 2.3 MJ/s during the night. Generally, GL4 has the lowest demand level, always below 0.5MJ/s across the selected day.

TABLE II
LENGTH OF PIPES IN THE TEST SYSTEM

Node	From node	To node	Length (km)
1	N1	N2	0.2
2	N1	GL2	0.6
3	N2	GL3	0.6
4	N2	GL4	0.3
5	N2	GL5	0.6
6	GL2	GL3	0.5
7	GL3	GL4	0.6
8	GL4	GL5	0.5
9	GL5	GL6	0.2

TABLE III
COMPOSITION OF THE NATURAL GAS (%)

	CH ₄	C ₂ H ₆	C ₃ H ₈	C ₄ H ₁₀	CO ₂	Other
Percent	79.6	8.3	4.9	1.4	3.4	2.4

For the wind farm in the electricity network, the following parameters are assumed: cut-in speed of 3 m/s, the rated output speed of 14m/s, and cut-out speed of 25m/s. The detailed composition of used North Sea gas is provided in Table III, where the main element is methane, taking up almost 80% of volume. The Wobbe indexes of North Sea gas and H₂ are 46.94MJ/m³ and 38.67MJ/m³ respectively. Their heat values are 40.03MJ/m³ and 10.21MJ/m³. The electrolyser conversion efficiency is 0.6 and the HHV is 3.509 kWh/Nm³.

In order to inject the maximum level of H₂ into the gas system, this paper proposes to mix it with LPG and N₂ to ensure gas quality. LPG mainly consists of propane (C₃H₈), butane (C₄H₁₀), and butylene in various mixtures, which is a by-product of natural gas processing and petroleum refining. Here, it assumes that C₃H₈ and C₄H₁₀ take up 50% and 50% in the LPG. Its high heat value is 115 MJ/m³, Combustion Potential is 42, and relative density is 2. LPG is to reduce Combustion Potential and increase Wobbe Index. By contrast, N₂ whose heat value and combustion potential are 0, is to make the mix more flexible.

7.2 No H₂ Injection – Case 1

In this case, there is no H₂ injection and therefore, the two energy systems are separately operated. The benchmark nodal gas pressures are given in Fig.5 and the source SP1's pressure (N1) is fixed at 0.8 barg. As gas demand fluctuates over time, it causes demand pressures to vary significantly. The pressures at all sites are relatively low during daytime from 7:00-18:00. When the site is far from the source, its pressure drops more rapidly due to pipeline frictions. For example, the pressure at GL6 drops below 0.045 barg at 17:00.

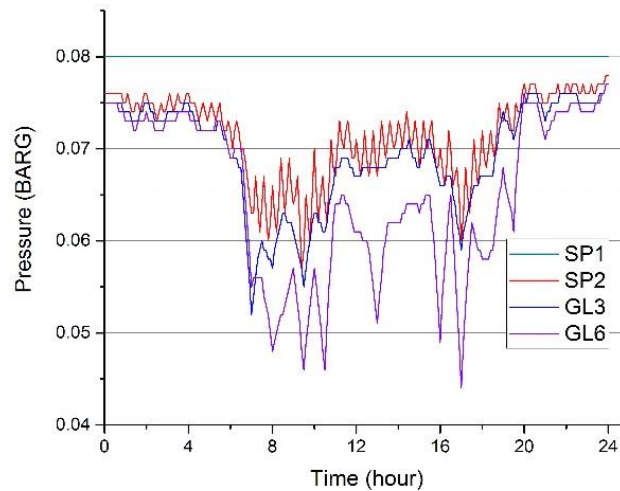

Fig.5. Pressures at selected nodes without H₂ injection

7.3 H₂ Injection without Management – Case 2

This subsection quantifies the impact of injecting H₂ from wind power into the natural gas system on gas system pressures and Wobbe Index without injection management. The site where H₂ is injected (node N2) is operated in 'Max Flow' mode. Fig. 6 depicts the percentage of H₂ (all overloading on the integration transformer is converted to H₂) over the total gas demand, which fluctuates dramatically over time. The percentage is low during the daytime, below 10%, as gas demand is high. From 20:00 onwards, the percentage climbs dramatically to almost 20% as the gas demand is low.

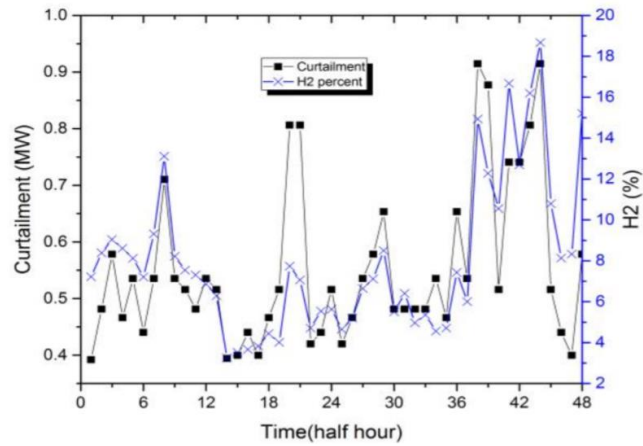

Fig. 6. The penetration of H₂ relative to demand.

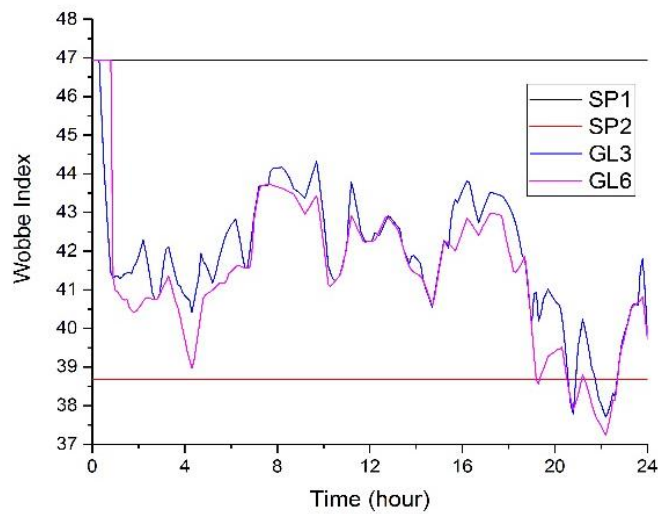

Fig.7. Wobbe Index at selected nodes with H₂ injection.

The Wobbe Indexes for selected locations are given in Fig. 7. Apparently, the indexes for all load locations (GL3 and GL6) follow very similar patterns, which have a sharp drop with H₂ injection. The indexes start to recover and fluctuate during the daytime but again drop to the minimum near 37MJ/m³ at 23:00. It is mainly because H₂ has small heat value and low density. By contrast, the Wobbe Indexes of both suppliers, SP1 and SP2, are constant over time.

7.4 H₂ Injection with Management - Case 3

This subsection injects H₂ into the natural gas system by mixing it with LPG and N₂ at the injection point. The Wobbe index and Combustion Potential of N₂ are both zero, but they are 86.84MJ/m³ and 42.4 respectively for LPG. The robust optimisation is used to manage the mixing.

Assuming that the H₂ injection is accurately controlled, when the volume of H₂ is given in an uncertain set, the detailed mixture of all three gasses is given in Table IV. Generally, with increasing H₂ injection, more LPG and N₂ are needed to increase Wobbe Index and decrease Combustion Potential. Take the first column as an example, where the input is H₂ injection, whose volume is within 1~1.1 m³. In order to ensure both Wobbe Index and Combustion Potential are within the statutory range, 1.12 m³ LPG and 1.02 m³ are needed to mix with the H₂. In this case, the Wobbe Index is in within [43.46~ 43.79] MJ/m³ and Combustion Potential is within [0.45 ~ 0.47]. However, when the potential injection range of H₂ increases to 1~1.5, no robust optimisation results can be obtained. When the H₂ injection range increases beyond 2 m³, solutions can be found again with the robust optimisation. These results roughly show how the different injection of H₂ would affect the requirements of LPG and N₂ in order to ensure gas quality.

TABLE IV
THE VOLUME OF MIXED GAS (m³)

Volume(m ³)			Percentage (%)			W	C _p
H ₂	LPG	N ₂	H ₂	LPG	N ₂		
1~1.1	1.12	1.02	31.78 ~ 33.89	34.61 ~ 35.71	31.49 ~ 32.49	43.46~ 43.79	0.45 ~ 0.47
1~1.2	1.24	1.17	29.32 ~ 33.23	34.36 ~ 36.37	32.41 ~ 34.31	43.01~ 43.62	0.43 ~0.47
1~1.3	1.36	1.03	29.56 ~ 35.29	36.86 ~ 40.13	27.84 ~30.31	45.98~ 47.04	0.44 ~ 0.50
1~1.4	1.48	1.08	28.14 ~ 35.41	37.30 ~ 41.50	27.29 ~ 30.36	46.41~ 47.78	0.43 ~ 0.50
1~1.5	No solution						
2~2.1	2.13	2.26	31.30 ~ 32.36	32.82 ~ 33.33	34.82 ~ 35.36	41.31~ 41.46	0.45 ~ 0.46
2~2.2	2.25	0.92	38.73 ~ 41.02	41.89 ~ 43.51	17.10 ~ 17.76	52.43~ 53.03	0.55 ~ 0.58
2~2.3	2.36	1.13	36.39 ~ 39.68	40.79 ~ 43.01	19.53 ~ 20.60	50.99~ 51.78	0.52 ~ 0.56
2~2.4	2.48	1.34	34.37 ~ 38.59	39.90 ~ 42.64	21.51 ~ 22.99	49.82~ 50.78	0.50 ~ 0.54

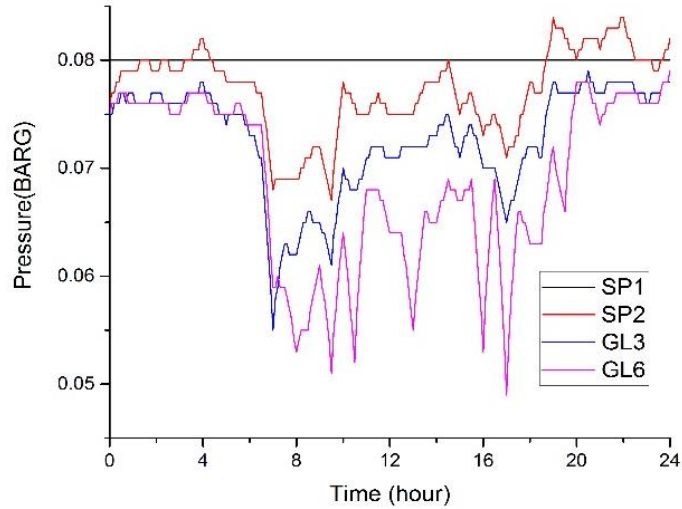

Fig. 8. Pressures at selected nodes with H₂ injection management.

Fig. 8 illustrates nodal pressures with the optimal management. Overall, all nodal pressures are higher than those in the first case, particularly for GL6, whose minimum is as high as 0.05 barg. It is noted that the pressure at SP2 (N2) during sometime is higher than that at SP1 (N1). It is mainly because that SP2 is operated under ‘Max Flow’ mode while SP1 is under ‘Constant Pressure’ mode, and thus more injection from SP2 can increase pressure.

The Wobbe indexes for the four selected nodes are given in Fig. 9. The indexes GL3 and GL6 are within the statutory range and they are much higher than those in the previous two cases. The minimum is around 40.5 MJ/m³ at 21:00. This justifies the effectiveness of the optimal management strategy to enhance system pressures and maintain gas quality.

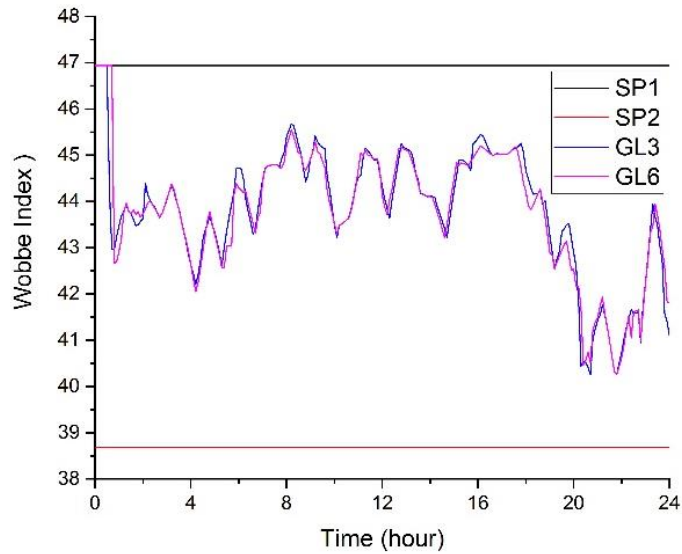

Fig.9. Wobbe Index in case 2.

7.5 Comparison of All Three Cases

Table V provides the two key indexes of measuring gas quality, Wobbe Index and Combustion Potential in all three cases at selected sites. Due to the large volume of data, only the Combustion Potential at 24:00 is provided.

TABLE V
COMBUSTION POTENTIAL IN THREE CASES

	Case 1	Case 2	Case 3
LG3	40.9	66.2	53.2
LG6	40.9	62.7	51.3

It can be seen that without H₂ injection, the Combustion Potentials for both LG3 and LG6 are very low, which is 40.9. With H₂ injection i.e. in Case 2, the Combustion Potentials at the two sites jumps to 66.2 and 62.7 respectively. The difference between the two values is caused by the dynamic flows of the injected H₂ that has high Combustion Potential. In case 3, with the optimal management, the index is significantly reduced to 53.2 and 51.3 respectively by using LPG and N₂ which have low Combustion Potentials indicating the effectiveness of the proposed management.

The gas flows at the source (N1) in all three cases are compared in Fig. 10. Clearly, in the first two cases, the gas supply profiles have very similar patterns, which mainly because that the percentage of H₂ is relatively low in the system, shown in Fig.6. Thus, the injection has a very limited impact on the gas supply. For the third case, as L₂ is mixed, it can significantly reduce the gas supply needed from SP, which brings the peak down to around 6.5MJ/s. The trough appears at 22:00 with the value of 1 MJ/s.

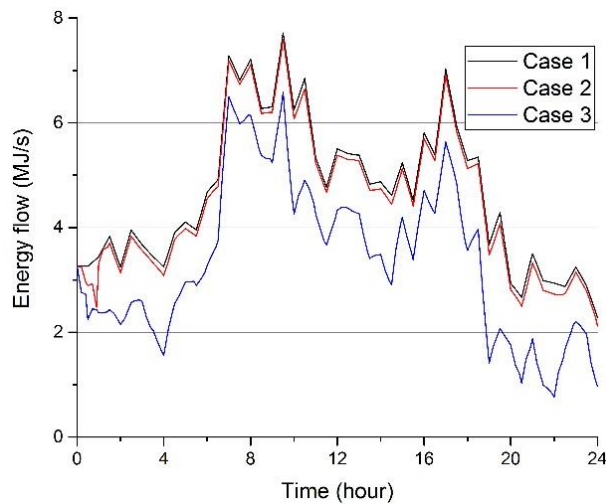

Fig. 10. Comparison of energy flow at source SP1.

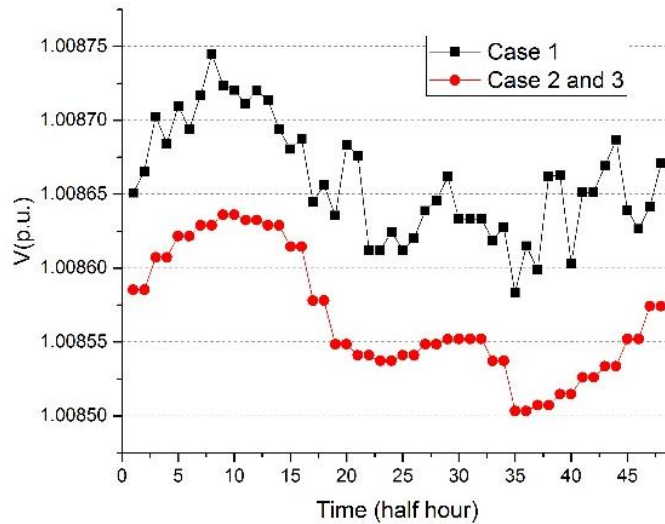

Fig. 11. The nodal voltage of busbar at the integration point.

Fig. 11 compares the voltages at busbar 5, where the wind farm is integrated into the electricity system. In all cases, the voltages generally drop from early morning and it has big volatility in case 1. In cases 2 and 3, the voltages are consistently lower than those in case 1, with the minimum reaching 1.0085p.u. When the exported wind power is curtailed, its voltage relative to that at busbar 1007 will thus drop as well.

8 DISCUSSION

In practice, when there is excessive renewable energy, particularly wind power and solar power, in the electricity systems, it has to be curtailed when the system thermal limits are violated. By using electrolysis, the excessive energy can be converted into H₂ to be transported by the natural gas system. This paper proposes a robust optimisation based novel management tool to manage H₂ injection by mixing it with LPG and N₂ to ensure gas quality. This tool can maximise H₂ injection produced from wind power, without affecting final gas quality. Generally, the tool can be used in the following steps:

- Predict the potential wind output and quantify the curtailment in order to avoid thermal limit violation;
- Calculate the potential H₂ produced from the excessive wind power by electrolysis;
- Set the constraints for Wobbe Index and Combustion Potential;
- Set other data, such as gas pipeline properties, compositions of other mixed gases;
- Input all data and information into the robust optimisation model to determine the amount of other gases needed for the mixture;
- Output final results regarding the amount of mixture gases in response to various H₂ penetration ranges.

9 CONCLUSION

This paper proposes a new robust optimal management tool for enabling the injection of H₂ converted from excessive wind power into natural gas systems. Through extensive demonstration, the following conclusions are reached.

- The injecting H₂ into gas systems significantly affects gas pressure variations. As the location is

further away from sources, the gas pressures drop dramatically. The dynamic models of gas pipelines can effectively capture the impact of gas demand variations on the system.

- H₂ injection significantly affects Wobbe Index and Combustion Potential as well. With increasing H₂, the Wobbe Index of the mixed gas declines gradually but the Combustion Potential increases. It justifies that the appropriate management of H₂ injection is essential for ensuring gas quality.

- The new robust optimal model can effectively manage H₂ injection into natural gas systems to deal with uncertainties from wind power. With the robust optimisation, both Wobbe Index and Combustion Potential are maintained within statutory ranges.

The proposed method can effectively manage the injection of H₂ from excessive wind power into the natural gas system with gas quality constraints met. The whole framework is also applicable to managing the injection of other biomass gases into natural gas systems. It is beneficial to energy systems operators, enabling them to maximise renewable injection without comprising supply quality.

References

- [1] McKenna RC, Bhini Q, Weinand JM, Michaelis J, König S, Köppel W, Fichtner W. The future role of Power-to-Gas in the energy transition: Regional and local techno-economic analyses in Baden-Württemberg. *Applied Energy*. 2018;212:386-400.
- [2] Dodds PE, Demoullin S. Conversion of the UK gas system to transport hydrogen. *International Journal of Hydrogen Energy*. 2013;38:7189-200.
- [3] Qadrdan M, Abeysekera M, Chaudry M, Wu J, Jenkins N. Role of power-to-gas in an integrated gas and electricity system in Great Britain. *International Journal of Hydrogen Energy*. 2015;40:5763-75.
- [4] Tabkhi F, Azzaro-Pantel C, Pibouleau L, Domenech S. A mathematical framework for modelling and evaluating natural gas pipeline networks under hydrogen injection. *International Journal of Hydrogen Energy*. 2008;33:6222-31.
- [5] Melo DFR, Chang-Chien LR. Synergistic Control Between Hydrogen Storage System and Offshore Wind Farm for Grid Operation. *IEEE Transactions on Sustainable Energy*. 2014;5:18-27.
- [6] Sarrias-Mena R, Fernández-Ramírez LM, García-Vázquez CA, Jurado F. Electrolyzer models for hydrogen production from wind energy systems. *International Journal of Hydrogen Energy*. 2015;40:2927-38.
- [7] Korpas M, Holen AT. Operation planning of hydrogen storage connected to wind power operating in a power market. *IEEE Transactions on Energy Conversion*. 2006;21:742-9.
- [8] Wang, Yang X, Wu Z, Che Y, Guo L, Zhang S, Liu Y. A Highly Integrated and Reconfigurable Microgrid Testbed with Hybrid Distributed Energy Sources. *IEEE Transactions on Smart Grid*. 2016;7:451-9.
- [9] Alkano D, Scherpen J. Distributed supply coordination for Power-to-Gas facilities embedded in energy grids. *IEEE Transactions on Smart Grid*. 2016;PP:1-.
- [10] Guandalini G, Colbitaldo P, Campanari S. Dynamic modeling of natural gas quality within transport pipelines in presence of hydrogen injections. *Applied Energy*. 2017;185:1712-23.
- [11] Li G, Zhang R, Jiang T, Chen H, Bai L, Li X. Security-constrained bi-level economic dispatch model for integrated natural gas and electricity systems considering wind power and power-to-gas process. *Applied Energy*. 2017;194:696-704.
- [12] He L, Lu Z, Zhang J, Geng L, Zhao H, Li X. Low-carbon economic dispatch for electricity and natural gas systems considering carbon capture systems and power-to-gas. *Applied Energy*. 2018;224:357-70.
- [13] Robinius M, Raje T, Nykamp S, Rott T, Müller M, Grube T, Katzenbach B, Küppers S, Stolten D. Power-to-Gas: Electrolyzers as an alternative to network expansion – An example from a distribution system operator. *Applied Energy*. 2018;210:182-97.
- [14] Abeysekera M, Wu J, Jenkins N, Rees M. Steady state analysis of gas networks with distributed injection of alternative gas. *Applied Energy*. 2016;164:991-1002.
- [15] Meher-Homji CB, Zachary J, Bromley AF. Gas turbine fuel- system design, combustion and operability Proceedings of the 39th turbo machinery symposium Texas A&M University , Texas2010.
- [16] Abbott DJ, Bowers JP, James SR. The impact of natural gas composition variations on the operation of gas turbines for power generation The Future of Gas Turbine Technology. Belgium 2012.

- [17] de Vries H, Mokhov AV, Levinsky HB. The impact of natural gas/hydrogen mixtures on the performance of end-use equipment: Interchangeability analysis for domestic appliances. *Applied Energy*. 2017;208:1007-19.
- [18] Jones DR, Al-Masry WA, Dunnill CW. Hydrogen-enriched natural gas as a domestic fuel: an analysis based on flash-back and blow-off limits for domestic natural gas appliances within the UK. *Sustainable Energy Fuels*. 2018;2:14.
- [19] Zhang Y, Hu Y, Ma J, Bie Z. A Mixed-Integer Linear Programming Approach to Security-constrained Co-optimization Expansion Planning of Natural Gas and Electricity Transmission Systems. *IEEE Transactions on Power Systems*. 2018:1-.
- [20] BP, IGU. *Guidebook to Gas Interchangeability and Gas Quality*. 2011.
- [21] Helgaker JF, Muller B, Ytrehus T. Transient Flow in Natural Gas Pipelines Using Implicit Finite Difference Schemes. *Journal of Offshore Mechanics and Arctic Engineering-Transactions of the Asme*. 2014;136.
- [22] Thorley A, Tiley C. Unsteady and transient flow of compressible fluids in pipelines—a review of theoretical and some experimental studies. *International Journal of Heat and Fluid Flow*. 1987;8:3-15.
- [23] Chertkov M, Fisher M, Backhaus S, Bent R, Misra S. Pressure Fluctuations in Natural Gas Networks caused by Gas-Electric Coupling. 2015 48th Hawaii International Conference on System Sciences (Hicss). 2015:2738-47.
- [24] Kiuchi T. An implicit method for transient gas flows in pipe networks. *International Journal of Heat and Fluid Flow*. 1994;15:378-83.
- [25] Zhou Y, Gu C, Wu H, Song Y. An Equivalent Model of Gas Networks for Dynamic Analysis of Gas-Electricity Systems. *IEEE Transactions on Power Systems*. 2017;PP:1-.
- [26] Zhou L, Li F, Gu C, Hu Z, Blond SL. Cost/Benefit Assessment of a Smart Distribution System With Intelligent Electric Vehicle Charging. *IEEE Transactions on Smart Grid*. 2014;5:839-47.
- [27] Billinton R, Wangdee W. Reliability-Based Transmission Reinforcement Planning Associated With Large-Scale Wind Farms. *Power Systems, IEEE Transactions on*. 2007;22:34-41.