

**Synthesis and Testing of Inhibitors of
Dihydrodipicolinate Synthase**

**A thesis presented in part fulfilment of the requirement
for the degree of Doctor of Philosophy.**

By John E. Mckendrick

Department of Chemistry, The University of Glasgow

December 1995

ProQuest Number: 13815616

All rights reserved

INFORMATION TO ALL USERS

The quality of this reproduction is dependent upon the quality of the copy submitted.

In the unlikely event that the author did not send a complete manuscript and there are missing pages, these will be noted. Also, if material had to be removed, a note will indicate the deletion.



ProQuest 13815616

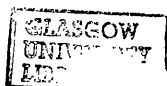
Published by ProQuest LLC (2018). Copyright of the Dissertation is held by the Author.

All rights reserved.

This work is protected against unauthorized copying under Title 17, United States Code
Microform Edition © ProQuest LLC.

ProQuest LLC.
789 East Eisenhower Parkway
P.O. Box 1346
Ann Arbor, MI 48106 – 1346

Heir
10324
Cp 1



"Life's disappointments are harder to take when you don't know any swear words"...Calvin (copyright Bill Watterson)

This thesis is dedicated to my wife Joyce the most precious and loving woman I have known

"If something is so complicated that you can't explain it in 10 seconds, then it's probably not worth knowing"...Calvin (copyright Bill Watterson)

Acknowledgements

I wish to thank my supervisor Professor D. J. Robins for all his help over the last three years and for his assistance in the preparation of this thesis. I would also like to thank Professor John Coggins for his help with all things biochemical and the use of his laser printer after the flood.

I would also like to thank my co-workers in the lysine group, namely Philip, Robert, Suzanne and Fong. Without these people the three years would not have been quite so much fun, they helped with the workload and made the days seem short (or was that the coffee breaks).

Philip and Robert deserve my deepest thanks because they saw me through my final year. Philip, thank you for reading this thesis and for being a Sci-Fi fan and a jolly good laugh. Robert, you kept me amused with stories from home and the way you behaved in the lab. Thank you Both.

Thanks also go to those in the Henderson lab, Paul, Greig, Lesley-Ann, Gerry and the others, too numerous to mention. Thanks to those in the Loudon lab for the good times over the years.

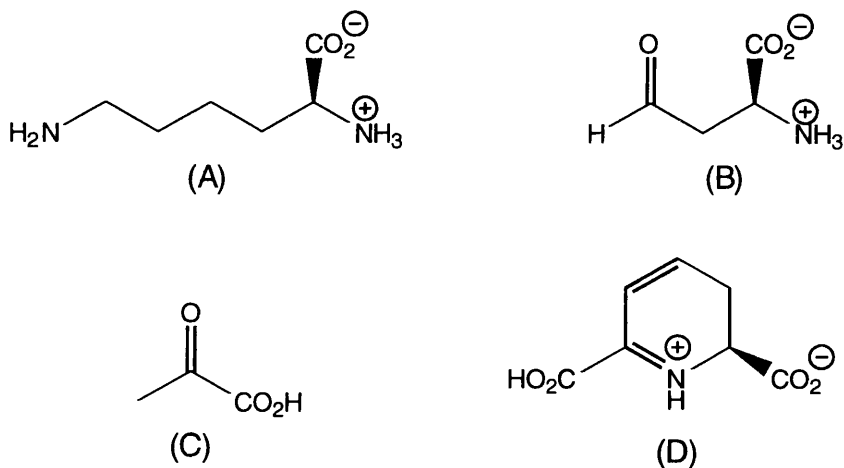
I would also like to take this opportunity to thank those in this department who helped me throughout the years. First must be Isabel Freer who did all the donkey work. Isabel I don't know how you cope, thank you. Thanks also go to: Mr. J. Gall, Dr. D. Rycroft, Mr. A. Ritchie, Mrs. K. Wilson and Mr G. McCulloch. A special mention must go to Cyber-Tec, James Tweedie for keeping the Henderson lab running smoothly.

I would like to thank Zeneca Biological products and the EPSRC for the funding of this project.

My mother and father deserve a mention for their support and finance. TO brother and sister I say keep trying and thank you. Finally I would like to thank my wife for her support over the last fifteen months. Thank you for following me to the ends of the earth.

Summary

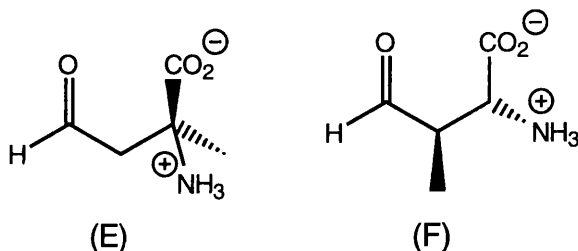
There are two distinct biosynthetic pathways to the essential amino acid L-lysine (A). The diaminopimelate pathway to L-lysine occurs in higher plants and bacteria. The second pathway known is the α -aminoadipate pathway and is found to operate in fungi and yeasts. This thesis will deal with only the diaminopimelate pathway to L-lysine and in particular with the first step, which involves the condensation of L-aspartic acid β -semialdehyde (ASA) (B) with pyruvate (C) to form L-dihydrodipicolinate (DHDP) (D). The mechanism of formation of L-DHDP (D) was studied using electrospray mass spectrometry. The synthesis and testing of potential inhibitors of dihydrodipicolinate synthase (DHDPS) was also studied.



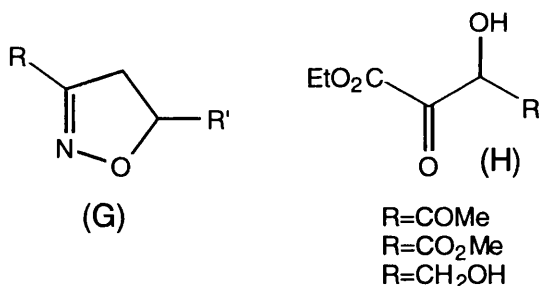
L-ASA is a substrate of the first enzyme of the diaminopimelate pathway to L-lysine. A former co-worker in the group, Dr D. Tudor had developed a route to L-ASA as the trifluoroacetate salt. This route was low yielding, approximately 14% for four steps, thus a higher yielding route was developed utilising the *para*-methoxybenzyl (PMB) ester protecting group. This material was not suitable for use in the biochemical assay as an impurity from the deprotection stage was found to absorb strongly at the wavelength used for the our enzyme assay system. An improved procedure for the synthesis of L-ASA was developed increasing the overall yield of the procedure to approximately 48% for the same four steps.

The synthesis of L-ASA as its trifluoroacetate salt allowed a number of analogues of L-ASA to be prepared with some synthetic modification of the original route. The compounds prepared this way were alkylated derivatives of L-ASA. The α -methyl ASA (E) was prepared by the reaction of methyl iodide with the anion generated from treating diprotected allylglycine with lithium

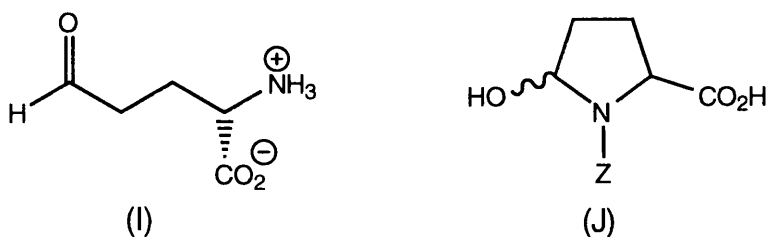
diisopropylamide (LDA). It proved to be a poor inhibitor but initial studies suggest that it may be a reasonably good substrate for DHDPS. A number of other derivatives were prepared including β -methyl ASA (F) which again was a poor inhibitor but was found to be a good substrate for DHDPS (β -methyl ASA is utilised at approximately 20% of the rate that L-ASA is consumed). A number of other derivatives and analogues of L-ASA were prepared.



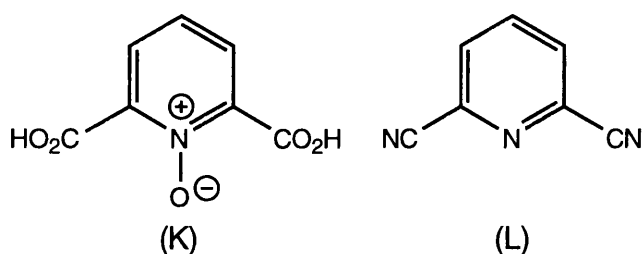
A number of heterocyclic compounds were prepared as analogues of DHDP and were tested for inhibitory effects with DHDPS. These compounds were prepared by a 1,3-dipolar cycloaddition of a nitrile oxide onto an alkene or alkyne. The isoxazolines produced had a general structure (G). These compounds were found to be poor inhibitors of DHDPS with none showing inhibition below 1 mM. The ring opened isoxazolines (H) were prepared as analogues of pyruvate but again they proved to be poor inhibitors of DHDPS.



An attempt to synthesise glutamic acid γ -semialdehyde (I) starting from glutamic acid was undertaken. The compound isolated from the series of reactions was found to have cyclised and was stable as the carbinolamine (J). This route was abandoned due to the cyclisation of the product.



A number of pyridinedicarboxylic acid derivatives and analogues were prepared to test for inhibitory activity. The pyridine-2,6-dicarboxylic acid *N*-oxide (K) and the pyridine-2,6-dinitrile (L) showed very good inhibitory activity. These compounds were studied in detail to determine the type of inhibition they showed. The two compounds (K) and (L) were found to be non-competitive inhibitors of DHDPS. A number of other saturated and unsaturated analogues of L-DHDP were prepared and tested for inhibitory action.



A study of the mechanism of DHDPS was undertaken using electrospray mass spectrometry to detect enzyme bound intermediates. The electrospray mass spectrometer was able to provide evidence for a number of pyruvate analogues bound to the enzyme as Schiff's bases. No evidence for L-ASA bound to DHDPS could be found. Further to these studies was the need to preserve stocks of DHDPS used for inhibitor testing and biotransformations. A study of the immobilisation of DHDPS on Eupergit resins was undertaken to determine the feasibility of this technique as a method of obtaining reusable DHDPS. The studies found that only up to 18% of the initial sample of DHDPS was bound to the beads. This suggests that this may not be a suitable method for the immobilisation of DHDPS, however DHDPS bound to the beads was found to have long term stability.

Table of Contents

		Page No.
Chapter One	Amino acids and L-lysine	1
1.1	Introduction	1
1.2	Amino acid biosynthesis	2
1.3	The importance of lysine	5
1.4	Production of L-lysine	9
1.5	Biosynthesis of L-lysine	11
	The α -aminoadipate pathway to L-lysine	12
	The diaminopimelate pathway to L-lysine	14
1.6	The design of inhibitors of the DAP pathway to L-lysine	17
Chapter Two	The diaminopimelate pathway to L-lysine	20
2.1	Introduction	20
2.2	Dihydrodipicolinate synthase (DHDPS) (EC 4.2.1.52, <i>dapA</i>)	20
2.3	Purification of DHDPS	22
2.4	Characterisation of DHDPS	24
2.5	Determination of the molecular weight of DHDPS from <i>E. coli</i>	25
2.6	The mechanism of DHDPS	26
2.7	Crystal structure of <i>E. coli</i> DHDPS	28
2.8	Inhibition and regulation of DHDPS	29
2.9	Dihydrodipicolinate reductase (DHDPR) (EC 1.3.1.26, <i>dapB</i>)	32
2.10	Isolation of DHDPR	32
2.11	Assay systems for DHDPR activity	33
2.12	Mechanism of DHDPR	34
2.13	Crystal structure of DHDPR	37
2.14	Inhibition of DHDPR	37
2.15	Succinyl CoA: L-tetrahydrodipicolinate <i>N</i> - succinyltransferase (THDP succinylase) (<i>dapD</i>)	38
2.16	Isolation and characterisation of THDP succinylase	38
2.17	Synthesis of L-THDP	39
2.18	Mechanism of THDP succinylase	40

2.19	Inhibitors of THDP succinylase	42
2.20	<i>N</i> -Succinyl-LL-diaminopimelate aminotransferase (EC 2.6.1.17, <i>dapC</i>)	44
2.21	Isolation and characterisation of succinyl diaminopimelate aminotransferase	44
2.22	Mechanism of <i>N</i> -succinyl diaminopimelate aminotransferase	45
2.23	Inhibition of <i>N</i> -succinyl diaminopimelate aminotransferase	46
2.24	<i>N</i> -Succinyl diaminopimelate desuccinylase (EC 3.5.1.18, <i>dapE</i>)	47
2.25	Isolation and characterisation of <i>N</i> - succinyl diaminopimelate desuccinylase	47
2.26	<i>meso</i> -Diaminopimelate epimerase (EC 5.1.1.7, <i>dapF</i>)	48
2.27	Isolation and characterisation of <i>meso</i> - DAP epimerase	48
2.28	Mechanism of <i>meso</i> -DAP epimerase	49
2.29	Inhibition of <i>meso</i> -DAP epimerase	51
2.30	<i>meso</i> -Diaminopimelate dehydrogenase (EC 1.4.1.16, <i>ddh</i>)	53
2.31	Isolation and characterisation of <i>meso</i> - DAP dehydrogenase	54
2.32	The mechanism of <i>meso</i> -DAP dehydrogenase	55
2.33	Inhibition of <i>meso</i> -DAP dehydrogenase	55
2.34	<i>meso</i> -Diaminopimelate decarboxylase (EC 4.1.1.20, <i>lysA</i>)	57
2.35	Isolation and characterisation of <i>meso</i> - DAP decarboxylase	57
2.36	The mechanism of <i>meso</i> -DAP decarboxylase	58
2.37	Inhibition of <i>meso</i> -DAP decarboxylase	58
Chapter Three	Synthesis of analogues of aspartic acid β - semialdehyde	62
3.1	Introduction	62
3.2	Synthetic procedures for the production of α -amino acids	63

	Alkylation of glycine derivatives to give α -amino acids	63
	Condensation reactions to produce α -amino acids	65
	Amination of α -halo acids	65
	Rearrangement reactions leading to α -amino acids	65
	Asymmetric synthesis of α -amino acids	66
3.3	Protecting groups in α -amino acid chemistry	68
3.4	Synthesis of aspartic acid β -semialdehyde	71
3.5	Preparation of alkylated aspartic acid β -semialdehyde derivatives	74
3.6	N-formyl aspartic acid β -semialdehyde	81
3.7	Succinic semialdehyde	83
3.8	Substitution of aspartic acid β -semialdehyde at the 3-position	84
3.9	Preparation of 2-amino-4-epoxypentanoate	91
3.10	Attempted preparation of α -difluoroallylglycine	92
3.11	Conclusions and future work	94
Chapter Four	Synthesis of isoxazolines as potential inhibitors of DHDP synthase	96
4.1	Heterocyclic compounds as inhibitors of DHDP synthase	96
4.2	Synthesis of isoxazolines	97
4.3	Mechanism of the 1,3-dipolar cycloaddition	98
	Selectivity of 1,3-dipolar cycloadditions	100
4.4	Synthesis of nitrile oxides	101
4.5	Synthesis of isoxazolines	103
	Preparation of isoxazolines via the Mukaiyama-Hoshino method	112
	Preparation of isoxazolines using dienes	114

	Preparation of <i>t</i> -butyl 2- <i>N</i> -(<i>t</i> - butoxycarbonylamino)-3-(3- ethoxycarbonyl)-2-isoxazolin-4-yl)- propanoate	115
4.6	Ring opening of isoxazolines to give α - keto esters	117
Chapter Five	Attempted synthesis of glutamic acid γ - semialdehyde	120
5.1	Introduction	120
5.2	Synthesis of glutamic acid γ - semialdehyde	121
5.3	Studies towards the enzymic product of GSA and pyruvate	125
5.4	Future work	129
Chapter Six	Synthesis of inhibitors of DHDP synthase	131
6.1	Pyruvate analogues	131
6.2	Saturated analogues of DHPD	132
6.3	Aromatic analogues of DHDP	133
6.4	Attempted preparation of thiinanes	135
6.5	Attempted synthesis of morpholine derivatives	136
6.6	Reduction of chelidonic acid	137
Chapter Seven	Studies with DHDP synthase and biological results	140
7.1	Introduction	140
7.2	Isolation of DHDPS from <i>E. coli</i>	141
7.3	Electrospray mass spectrometry studies on DHDPS	142
7.4	Immobilisation of DHDPS on Eupergit resins	147
7.5	Test results from inhibition studies with DHDPS	150
7.6	Determination of the type of inhibition using (43) and (44)	154
Chapter Eight	Experimental	157
8.1	General notes	157

8.2	Experimental detail for chapter three	158
8.3	Experimental detail for chapter four	192
8.4	Experimental detail for chapter five	203
8.5	Experimental detail for chapter six	215
References		227

Abbreviations

Acetyl CoA	Acetyl co-enzyme A
ATP	Adenosine triphosphate
ASA	Aspartic acid β -semialdehyde
BOC	<i>t</i> -Butyloxycarbonyl
Cbz	Carbobenzyloxy
DAP	Diaminopimelate
DEAE-Sephacel	Diethylaminoethyl-sephacel
DHDP	Dihydrodipicolinic acid
DHDPR	Dihydrodipicolinic acid reductase
DHDPS	Dihydrodipicolinate synthase
DHT	3,4-Dihydro-2 <i>H</i> -1,4-thiazine-3,5-dicarboxylic acid
DIBAL-H	Diisobutylaluminium hydride
DMF	Dimethyl formamide
DNP	Dinitrophenylhydrazine
DPA	Dipicolinic acid
d	Doublet
ESMS	Electrospray mass spectrometry
GSA	Glutamic acid γ -semialdehyde
IR	Infrared
LDA	Lithium diisopropylamide
MHz	Mega hertz
mp	Melting point
μ M	Micromolar
mg	Milligram
ml	Millilitre
mM	Millimolar
mmol	Millimole
M	Molar
m	Multiplet
nm	Nanometer
nM	Nanomolar
NADH	Nicotinamide adenine dinucleotide
NADPH	Nicotinamide adenine dinucleotide phosphate
NMR	Nuclear magnetic resonance
p	<i>para</i>
q	Quartet
s	Singlet

SDS-Page	Sodium dodecyl sulfate-polyacrylamide gel electrophoresis
Succinyl CoA	Succinyl co-enzyme-A
THDP	Tetrahydrodipicolinic acid
THF	Tetrahydrofuran
TFA	Trifluoroacetic acid
t	Triplet
UV	Ultraviolet

Chapter One: Amino Acids and L-Lysine

1.1 Introduction

α -Amino acids are found in all living organisms in both their free form and joined together by amide linkages to form highly complex polymers called proteins. Over the last 100 years techniques have improved to the extent that it is known now that upwards of 1000 different amino acids occur naturally. This increase in the number of naturally occurring amino acids has led to an increase of activity within pharmaceutical companies. They often make use of amino acids as chirons for the synthesis of novel drug substances in optically active form.

With the blossoming use of amino acids as building blocks for many new drug substances has arisen the interest in utilising the polymeric form of amino acids, namely proteins, to catalyse transformations. These enzymic transformations are usually achieved with very high enantiomeric or diastereomeric excess, which is often a very difficult problem using modern synthetic chemical techniques.

There are only 21 of the 1000 or so amino acids that are genetically encoded and incorporated into proteins. The first proteinogenic amino acid to be discovered was glycine, quickly followed by leucine and then by 1920, 20 of the 21 proteinogenic amino acids had been discovered.¹⁻³ All of the amino acids except glycine are chiral and are mainly found in the L-form at the α -carbon. Only the L-forms are incorporated into proteins. The general structure of amino acids is shown in **figure 1**.

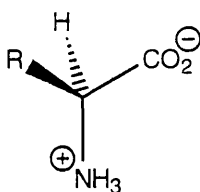


Figure 1: General structure of L- α -amino acids.

The R groups vary widely, and **figure 2** shows the R groups for the 21 genetically encoded amino acids. The R group functionality allows subdivision into families of hydrophobic, acidic, basic and hydrophilic amino acids. A given amino acid may be found in more than one category e.g. aspartic acid is both acidic and hydrophilic. Lysine (1) is itself basic and the biosynthesis of it and all

the amino acids will be discussed in the following section. The biosynthesis of lysine (1) will be discussed in greater detail in chapter two.

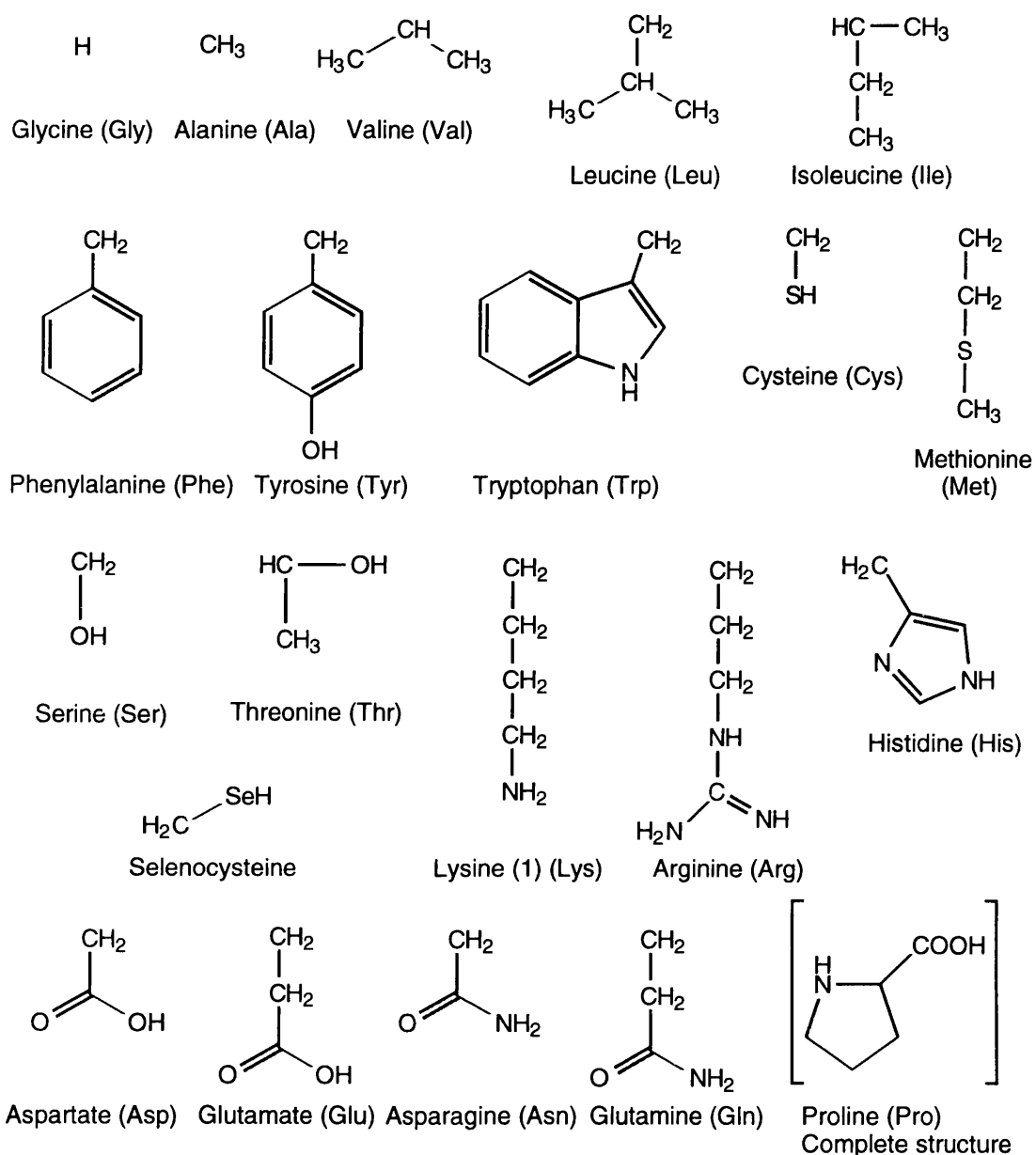


Figure 2: R groups for the 21 genetically encoded α -amino acids.

1.2 Amino acid biosynthesis

Many metabolic differences exist between the plant and animal kingdoms. Plants, unlike animals, are self sufficient, that is they obtain energy by harvesting light via the process of photosynthesis. This enables plants to obtain all the energy that is required for the biosynthesis of the wide diversity of compounds they require. Plants can synthesise all of the required α -amino acids and vitamins whereas animals need to obtain a large number of the α -amino acids and vitamins from their diet. **Figure 3** shows the pathways by

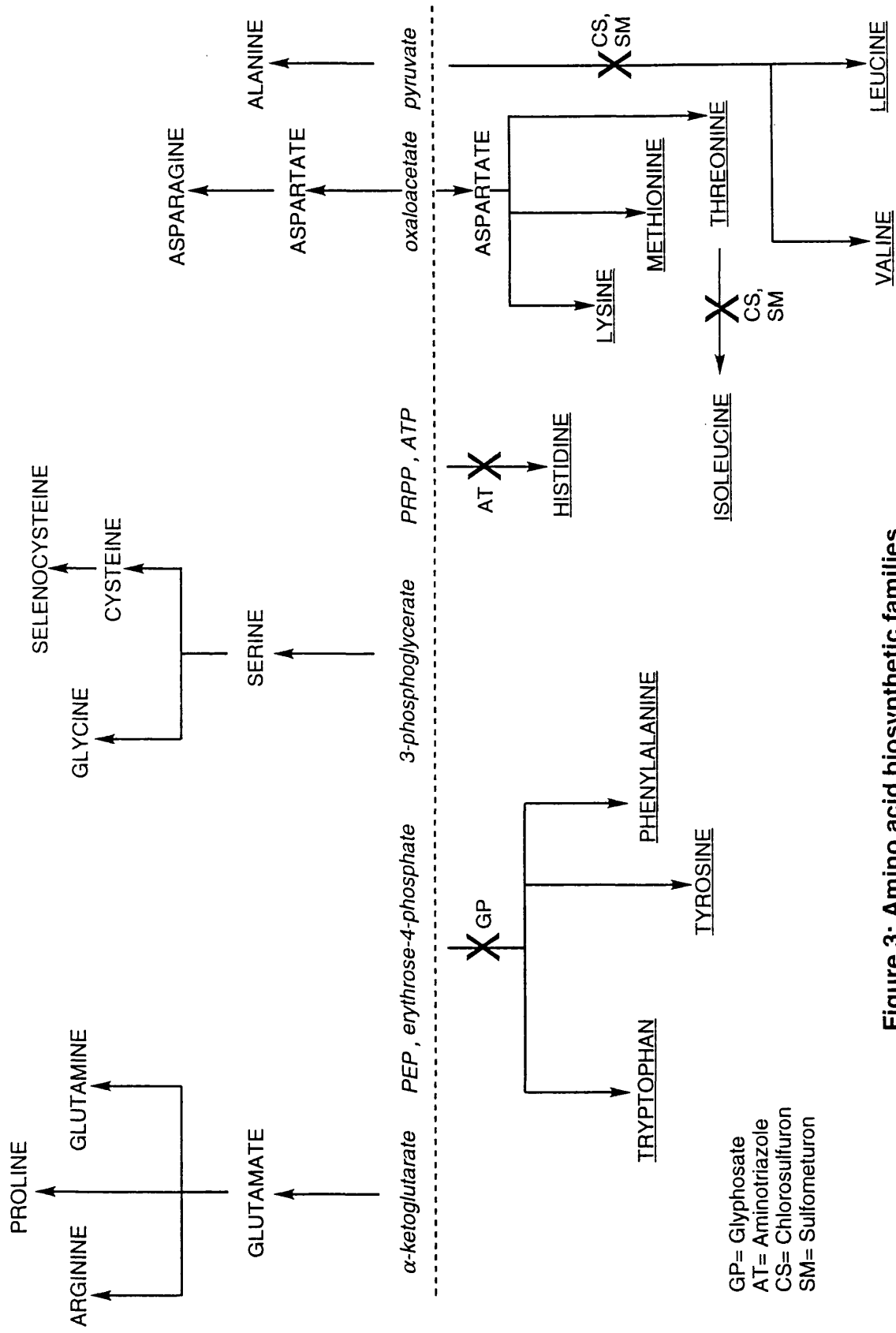
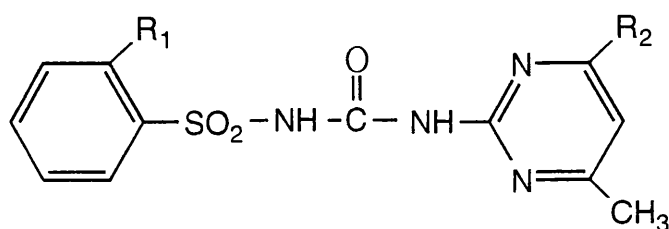
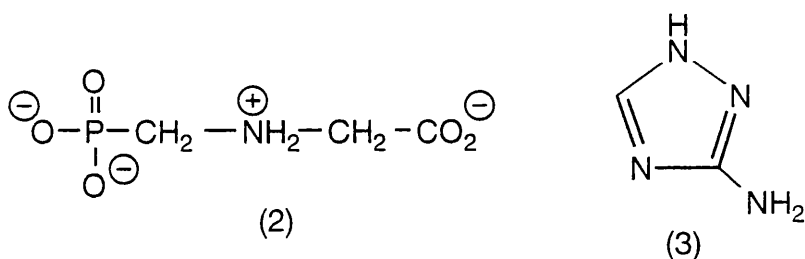


Figure 3: Amino acid biosynthetic families

which plants derive the α -amino acids. Common intermediates define families of biosynthetically related α -amino acids. Amino acids essential for the mammalian diet are underlined. Pathways below the dashed line do not occur in mammals but are found in plants and bacteria.

It can be seen from **figure 3** that all 21 of the genetically encoded α -amino acids can be generated from 6 biochemical pathways. All of the building blocks for the biosynthesis of the amino acids are generated by the processes of glycolysis, the pentose phosphate pathway and the citric acid cycle.

A number of herbicides are known to act by inhibiting essential amino acid biosynthesis. The biosynthetic pathways which each herbicide inhibits are marked by a cross in **figure 3**. Glyphosate (GP) (2) is a non-selective herbicide which inhibits general aromatic amino acid biosynthesis.^{4,5} Aminotriazole (AT) (3) was patented as a broad spectrum herbicide by the American Paint Company. It was found to act by antagonising histidine biosynthesis by blocking the activity of imidazole glycerol phosphate dehydratase.⁶ The sulfonylurea herbicides, chlorosulfuron (CS) (4) and sulfometuron methyl (SM) (5) are notable for their high potency and low mammalian toxicity.⁷ While sulfometuron methyl (5) is a broad spectrum non-selective herbicide, chlorosulfuron (4) is selective and can be used to prevent the growth of weeds without harming commercially important crops. Both of these compounds inhibit the biochemical pathways to branched chain amino acids.



(4) $R_1 = \text{Cl}$, $R_2 = \text{OCH}_3$

(5) $R_1 = \text{CO}_2\text{CH}_3$, $R_2 = \text{CH}_3$

The biosynthesis of essential amino acids has been an area of active research for many years. The ability to design selective herbicides and antibacterial agents is the driving force for continued research in this area. As biochemical and genetic techniques have advanced, more information about the biochemical pathways has emerged. We are now at the point where rational design can take place to obtain the next generation of compounds which will tackle the growing threat of resistance to current agents.

The biochemical pathway to L-lysine (1) has not received much attention until recently. It is a good pathway from which new herbicides and anti-bacterial agents could be generated. Our research at Glasgow has been looking at the early stages of the biosynthetic pathway as found in plants and bacteria. An account of the biosynthetic pathway to lysine can be found in section 1.5 of this thesis, along with the design and synthesis of potential inhibitors of the first step in the pathway.

1.3 The importance of lysine

Lysine is an economically important amino acid. Mammals cannot biosynthesise lysine and must therefore consume it as part of their diet. Lysine is therefore an essential amino acid for animals and mammalian nutrition. The nutritive value of a protein depends on the quantity and balance of its constituent amino acids. Figures for the estimated daily requirement for the essential mammalian amino acids are given in **table 1**.

Amino acid	Required daily amount (mg/kg)
Isoleucine	10
Leucine	14
Lysine	12
Methionine	13
Phenylalanine	14
Threonine	7
Tryptophan	4
Valine	10

Table 1: Dietary requirements for the essential amino acids

The consumption of the essential amino acids must meet the daily minimum or the whole protein synthesis system is affected. The level of amino acid usage is lowered, in mammals, to the level of the limiting amino acid. Under such conditions protein is broken down to provide an extra source of the limiting

amino acid. Lysine (1) is often the limiting amino acid in food crops, especially cereal protein. It has been necessary, in the past, to supplement the lysine content of feed stock by the addition of the required daily minimum amount. Commercially the largest producers of lysine (1) are the bacteria *Corynebacterium glutamicum*, *Brevibacterium flavum* and *B. lactofermentum*.⁸ The developments in the production of lysine (1) will be discussed in section 1.4.

The biosynthesis of lysine in plants and bacteria is not fully understood. It has been shown by labelling studies that the pathway in bacteria proceeds through the intermediate *meso*-2,6-diaminopimelic acid (6).⁹ *meso*-2,6-Diaminopimelic acid (6) is known to be utilised in the peptidoglycan cell wall of many Gram positive and negative bacteria. The *meso*-2,6-diaminopimelic acid (6) is found as part of the cross-linking material of the cell walls, lending mechanical strength to the wall.¹⁰ **Figure 4** shows how *meso*-2,6-diaminopimelic acid (6) is utilised, where a pendant penta-peptide is branched off a polymer of *N*-acetylmuramic acid (NAM) and *N*-acetylglucosamine (NAG).

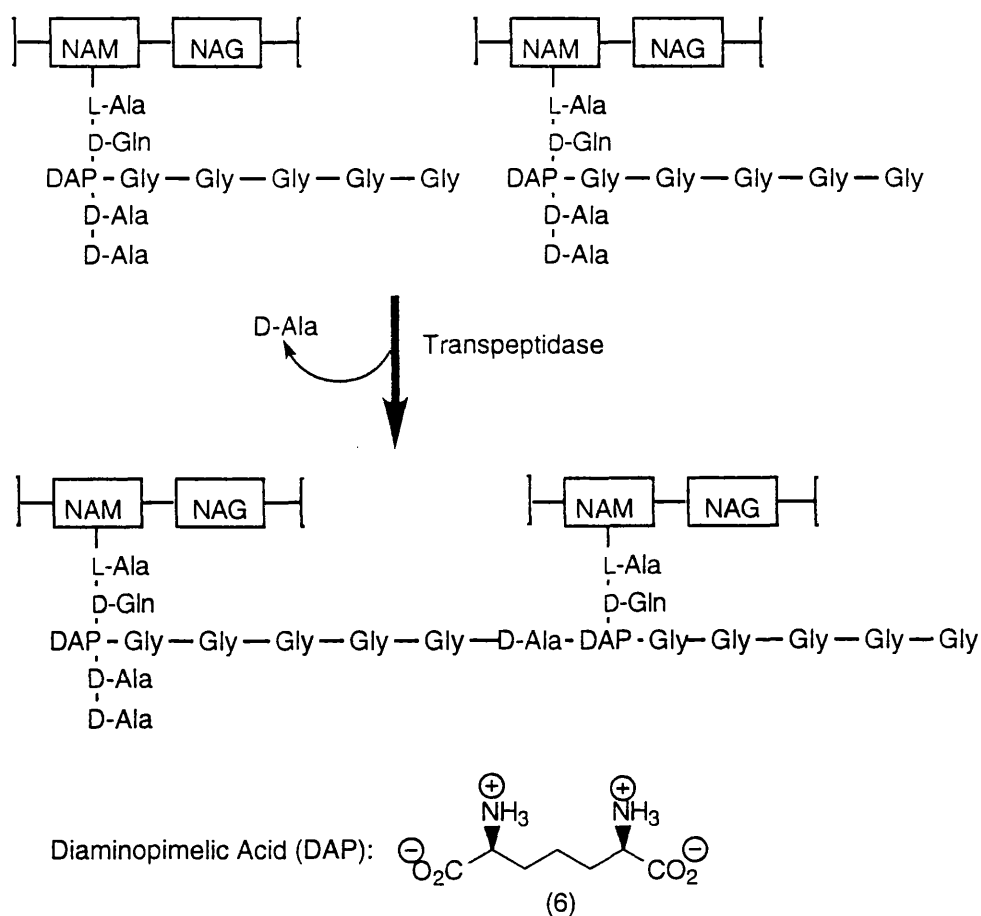


Figure 4: Utilisation of *meso*-2,6-diaminopimelic acid in bacterial cell walls

Inhibitors of peptidoglycan biosynthesis can possess powerful antibiotic properties; and one such drug is Vancomycin.^{10,11} The utilisation of an important intermediate of lysine (1) biosynthesis in cell wall strengthening makes the enzymes of lysine biosynthesis an important area to study. An understanding of the pathway could lead to better inhibitors and better therapies for bacterial infections. These compounds would be of further importance as the biosynthetic pathway to lysine (1) is not present in mammals. The drugs might therefore possess an excellent mammalian safety profile.

The conversion of lysine (1) into alkaloids is an important biological process which has been widely studied for many years. Alkaloids are a diverse group of natural products containing a nitrogen heterocycle. They are found mainly, but not exclusively, in plants. They are known for their wide range of biological activities, e.g. quinine (antimalarial); colchicine (gout suppressant); rescinnamine (anti-hypertensive); and morphine (analgesic). The isolation of large numbers of alkaloids has been accompanied by an increase in the understanding of their biological properties and their pharmacological, toxicological and ecological significance in nature. The use of isotopically labelled precursors in feeding experiments has helped to understand the complex nature by which alkaloids are biosynthesised. Alkaloids are biosynthesised in plants from a small subset of α -amino acids (lysine, ornithine, phenylalanine, tryptophan and tyrosine) along with mevalonate and acetate. Alkaloids have found importance in many fields such as medicine, industry and chemistry.

There are two main classes of alkaloid which utilise lysine (1) as a precursor, namely the piperidine alkaloids and the quinolizidine alkaloids. Both of these types of alkaloid occur in a limited number of plant species.

Many higher plants possess the necessary machinery to synthesise piperidine alkaloids. In each case these alkaloids possess one or more piperidine rings. **Figure 5** shows the biosynthetic pathway taken from lysine in the production of a piperidine alkaloid, anabasine (8). Robins and co-workers¹² studied the biosynthesis of anabasine (8) in transformed root cultures of *Nicotiana rustica* and *N. tabacum* using cadaverine (7) precursors labelled with deuterium. These labelling studies indicated that the *pro-R* hydrogen of cadaverine is retained at the position that becomes C-2' of anabasine.

Quinolizidine alkaloids are of importance because they exhibit toxicity to humans and livestock as constituents of poisonous plants, and also have a

range of useful pharmacological properties. These alkaloids are normally found in species of the genus *Lupinus* from the plant family Fabaceae. The biosynthesis of quinolizidine alkaloids starts with a decarboxylation of lysine (1) to give cadaverine (7), in an analogous fashion to that described for the piperidine alkaloids. The initial step is analogous to the first step in the formation of pyrrolizidine alkaloids; namely the decarboxylation of ornithine to putrescine.¹³

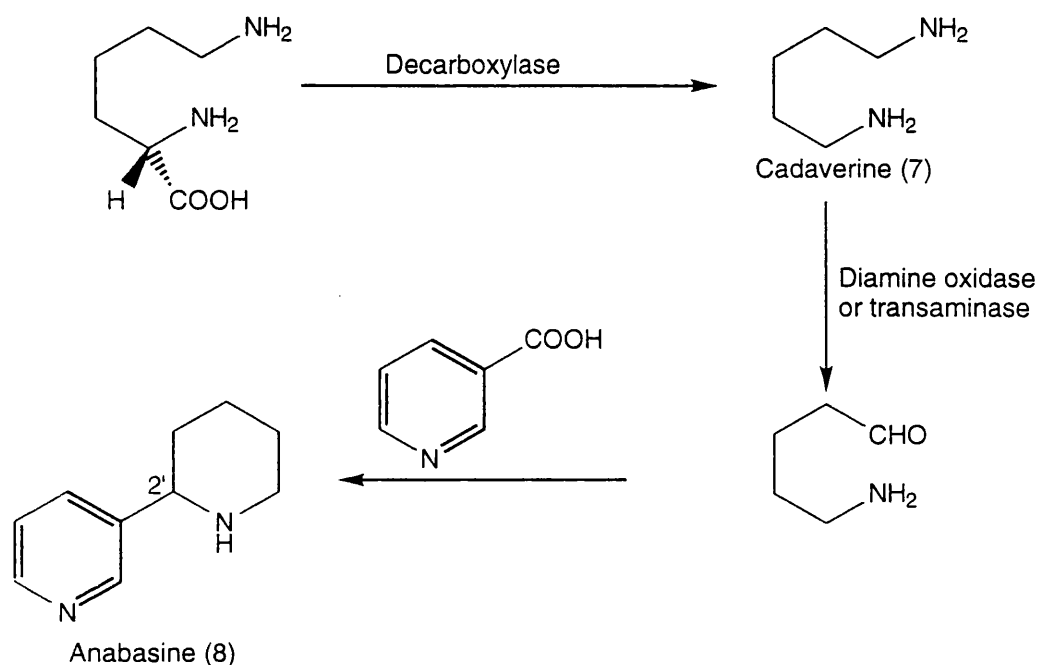


Figure 5: Biosynthesis of anabasine (8), a piperidine alkaloid from L-lysine (1)

From this point on the two biosynthetic pathways differ. The route to the pyrrolizidine alkaloids involves a symmetrical intermediate (C_4-N-C_4), whereas the biosynthetic pathway to quinolizidine alkaloids does not involve an analogous (C_5-N-C_5) symmetrical intermediate. The most common quinolizidine alkaloid is sparteine (9). It has been isolated from many plant species including *Spartium scoparium*,¹⁴ *Sarothamnus scoparius*,¹⁵ *Lupinus lindeniancus*¹⁶ and *Lupinus laxus* Rydb.¹⁷ Careful labelling studies by the groups of Robins¹⁸ and Spenser¹⁹ showed that there were equal levels of ^{13}C enrichment for six carbon atoms in sparteine after feeding [^{13}C - ^{15}N]-1,5-diaminopentane (cadaverine (7)), and that there were two ^{13}C - ^{15}N doublets in the ^{13}C NMR spectrum. This confirmed that two molecules of cadaverine (7) are incorporated into the two outer rings of sparteine (9) in a specific manner as shown in **figure 6**. The biosynthesis of quinolizidine alkaloids has been reviewed recently.²⁰

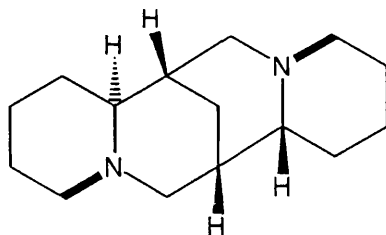
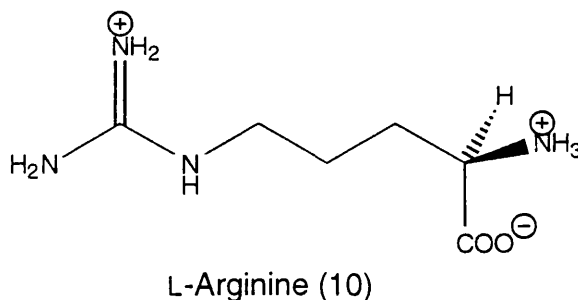


Figure 6: labelling pattern of sparteine (9) after feeding with [^{13}C - ^{15}N]-1,5-diaminopentane

Lysine (1) and arginine (10) play an important role in molecular interactions in biological systems because of their basic groups. It is well known that lysine (1) and arginine (10) are indispensable for the growth of microbes,²¹⁻²⁴ plants²⁵⁻²⁷ and animals.²⁸⁻³⁰ Furthermore an antagonistic role between these two amino acids has also been observed in living organisms.^{31,32} Antagonism between lysine (1) and arginine (10) has been clearly demonstrated by their effect on animal tissues. Either oral or peritoneal administration of a large dosage of lysine (1) or arginine (10) has been found to produce a highly significant change in the growth of transplantable tumours in mice.^{33,34} L-Lysine (1) strongly inhibited tumour growth while L-arginine (10) promoted the growth of the tumour. Administration of the enantiomer D-lysine promoted the growth of the tumour while D-arginine retarded its growth.



From the description above it is easy to see that L-lysine (1) plays a crucial role in nature. Hence, L-lysine (1) biosynthesis in both plants and micro-organisms is of considerable practical importance. There are two main pathways to L-lysine (1). These are the α -aminopimelate (AAP) and the diaminopimelate (DAP) pathways which will be discussed in section 1.5.

1.4 Production of L-lysine

The amino acid industry has been growing steadily since monosodium glutamate was marketed as a flavouring material in 1909. All of the proteinogenic amino acids are now produced industrially by at least one method. α -Amino acids can be produced by extraction of protein hydrolysates; after fermentation with the aid of micro-organisms; by enzymic processes with

genetically engineered bacteria; and by chemical syntheses. L-Lysine (1) is prepared industrially by direct fermentation methods and by biotransformation utilising both chemical and microbial techniques.

With the development of modern genetic techniques, it is possible to produce most proteinogenic amino acids by fermentation methods. The bacteria are engineered to stockpile L-lysine (1) by specific mutation of the wild type bacteria. Monosodium glutamate and L-lysine (1) are produced in the largest amounts industrially with annual production of 370,000 and 40,000 tons respectively.³⁵

Two types of genetically engineered bacteria are used to stockpile the desired amino acid; auxotrophic and regulatory mutants. Auxotrophic mutants are engineered so that they lack the enzymes necessary for the production of a certain compound and thus they must be supplied with that compound in the growth medium to enable the growth of the organism. For the production of large quantities of L-lysine (1), it is desirable to knock out the pathway to L-methionine, L-threonine and L-isoleucine to concentrate all of the L-aspartic semialdehyde down the lysine biosynthetic pathway. This is achieved by using mutants without homoserine dehydrogenase (usually *E. coli* or *C. glutamicum*) and leads to an accumulation of L-lysine (1) as shown in **figure 7**.³⁶

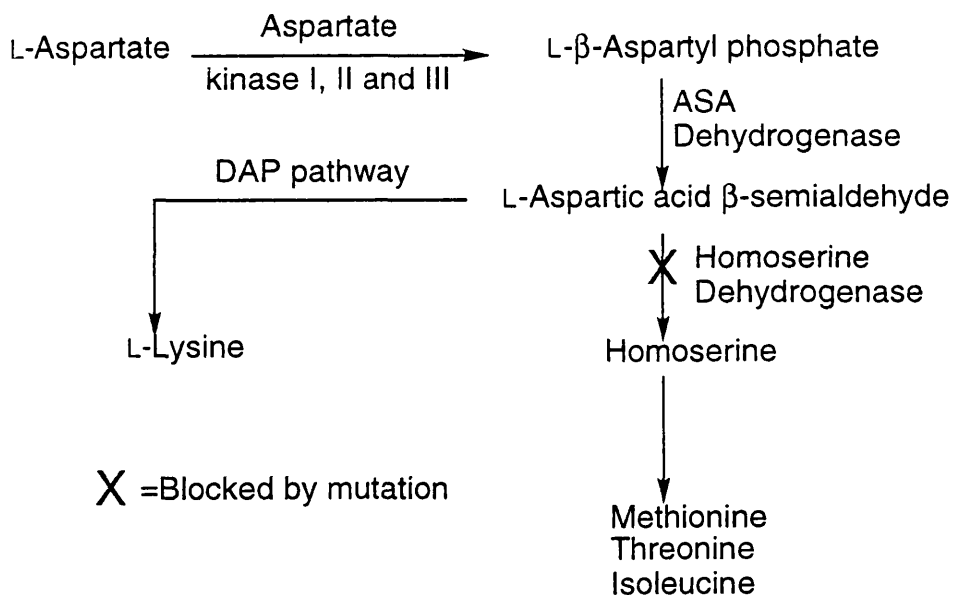


Figure 7: Accumulation of L-lysine by a mutant lacking homoserine dehydrogenase

Regulatory mutants are genetically modified in a different manner. The organism loses its ability to stop or slow down production of a required material. This is usually in the form of a mutation of one protein in the biosynthetic

pathway so that the organism does not respond to the information telling it to slow down its turnover of intermediates in the pathway. L-Lysine is produced in this manner by the mutated bacterium *B. flavum*.³⁷

A biotransformation approach to the industrial production of L-lysine is achieved using DL-aminocaprolactam (11), synthesised from cyclohexene.³⁸ Addition of L-aminocaprolactam hydrolase (*Cryptococcus laurentii*) and aminocaprolactam racemase (*Achromobacter obae*) results in the complete enzymic conversion into L-lysine (1), shown in **figure 8**.

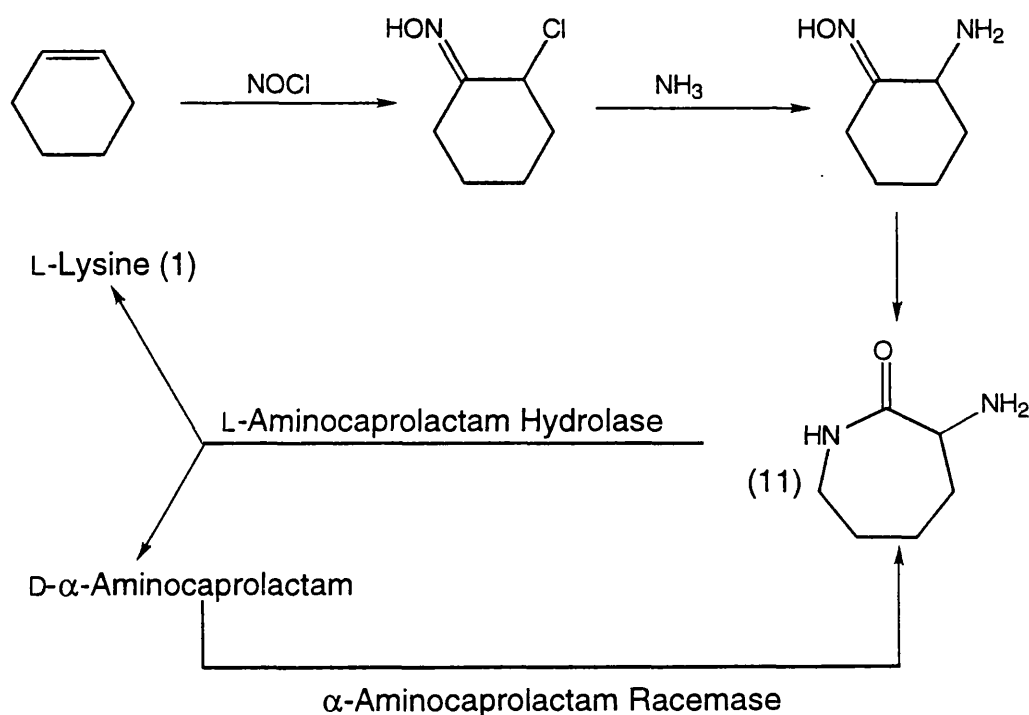


Figure 8: Biotransformation approach to production of L-lysine

1.5 Biosynthesis of L-lysine

L-Lysine (1) is biosynthesised via two pathways found in different organisms: the AAA pathway and the DAP pathway. The AAA pathway, **figure 9**, is found in Euglenids, some Phycomycetes (Chytridiales, Blastocladales and Mucorales), yeasts and higher fungi (Ascomycetes and Basidiomycetes). It starts with the reaction of 2-oxoglutaric acid (12), a product of the Krebs cycle, with acetyl-CoA and involves the synthesis of amino adipic acid (18) and saccharopine (20) as intermediates on the way to L-lysine (1). The DAP pathway, **figure 12**, occurs in bacteria and higher plants and presents a totally different approach to the synthesis of L-lysine (1). The initial reaction involves the condensation of pyruvic acid (32) with aspartic acid β -semialdehyde (ASA) (23) to form dihydrodipicolinic acid (27). Several unique enzyme-catalysed

steps then transform this condensed product, via *meso*-diaminopimelate (6), into L-lysine (1).

The α -aminoadipate pathway to L-lysine.

Labelling studies utilising radioactive ^{14}C -acetate have shown that, in *Saccharomyces cerevisiae*, the carbon skeleton of lysine (1) is built up of acetate units via the Krebs cycle.³⁹ The proposed pathway for the formation of lysine (1) in yeast, **figure 9**, involves the condensation of acetate with 2-oxoglutarate (12) to yield homocitrate (13) followed by a set of reactions which are analogous to those found in the citric acid cycle.⁴⁰

Lysine biosynthesis has been investigated in detail in *S. cerevisiae*.⁴¹ The enzymes of α -aminoadipate biosynthesis, namely homocitrate synthase, homoaconitate hydratase, homoisocitrate dehydrogenase and aminoadipate aminotransferase, are all localised in the mitochondria. A second aminoadipate aminotransferase has been identified free in the cell. The rest of the enzymes of the pathway are also non-mitochondrial.⁴² It is therefore important that transport of the precursors, α -aminoadipate and α -ketoadipate, to the cytosol is efficient. The story in plants is somewhat different with none of the enzymes free in the cell.

The first intermediate of the AAA pathway is formed by the condensation of 2-oxoglutaric acid (12) with acetyl-CoA to produce homocitrate (13). The reaction requires both ATP and acetyl-CoA and is catalysed by the enzyme homocitrate synthase. A dehydration reaction then converts homocitrate (13) into homoaconitate (14), catalysed by the enzyme homocitrate hydratase. Homoaconitate hydratase then converts homoaconitate (14) into homoisocitrate (15). Action of homoisocitrate dehydrogenase converts homoisocitrate (15) into oxaloglutarate (16). This enzyme is dependent on NAD and Mg^{2+} for its action.⁴³ Oxaloglutarate is an enzyme-bound intermediate and after a spontaneous decarboxylation the product, α -ketoadipate (17), is released from the enzyme.

Aminoadipate aminotransferase then converts α -ketoadipate (17) into α -aminoadipate (18), via a pyridoxal phosphate dependent transamination reaction with glutamate as the amino donor.⁴² Conversion of α -aminoadipate (18) into α -aminoadipate semialdehyde (19) using the enzyme aminoadipate dehydrogenase is the next step. This enzyme catalyses the reaction via a multi-step pathway utilising ATP, NADPH and Mg^{2+} .⁴⁴

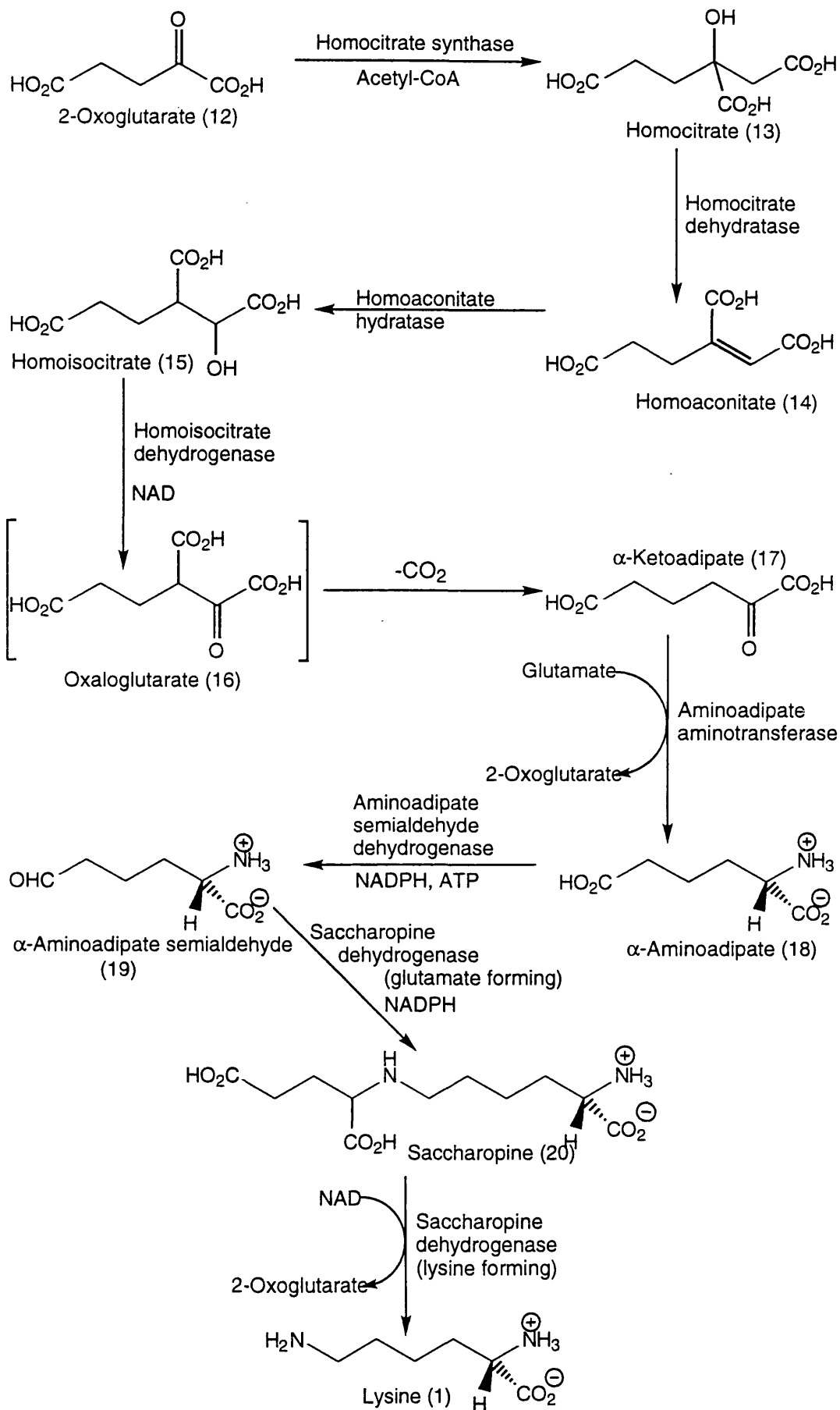


Figure 9: The α -aminoadipate pathway to L-lysine.

The reduction of α -aminoadipate (18) to α -aminoadipate semialdehyde (19) in *Saccharomyces* has been shown to be a three stage process. The amino acid first reacts with ATP to form an adenylyl- α -aminoadipate derivative, releasing orthophosphate. This derivative is then reduced in the presence of NADPH. The reduced adenylyl derivative is then cleaved to form aminoadipate semialdehyde (19), as shown in **figure 10**.

Two steps remain in the pathway to lysine (1). The first step is the condensation of α -aminoadipate semialdehyde (19) with glutamate to give saccharopine (20), catalysed by saccharopine dehydrogenase (glutamate forming). This enzyme requires glutamate and NADPH to facilitate the conversion. The final stage is the conversion of saccharopine (20) into lysine (1) by the enzyme saccharopine dehydrogenase (lysine forming). This enzyme cleaves saccharopine into lysine (1) and 2-oxoglutarate (12).⁴⁵

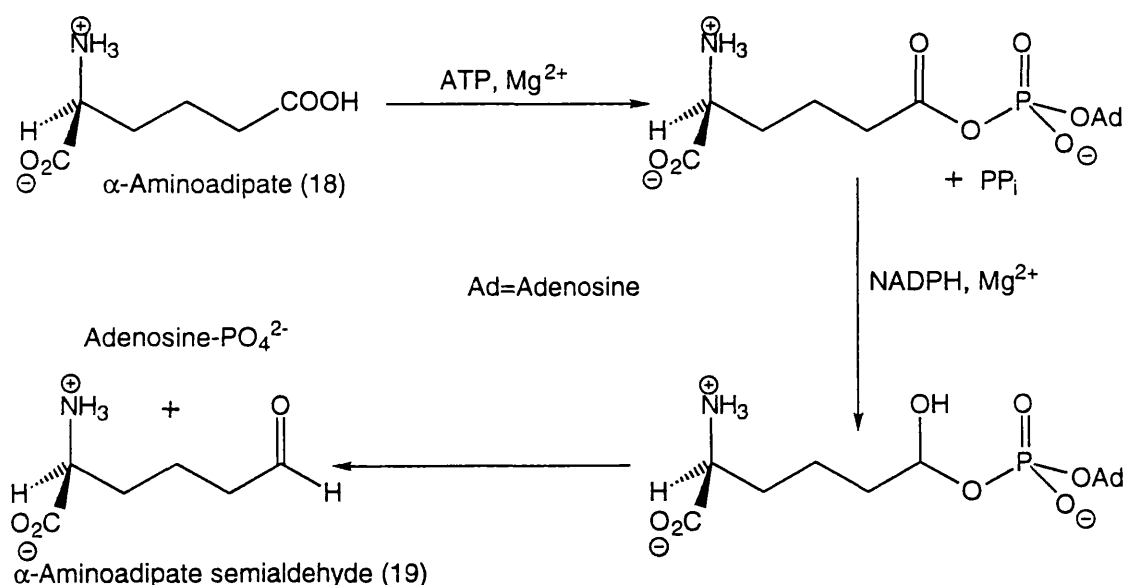


Figure 10: Reduction of α -aminoadipate by aminoadipate semialdehyde dehydrogenase

The diaminopimelate pathway to L-lysine

As mentioned previously lysine (1), threonine (24), isoleucine (25) and methionine (26) belong to the aspartate family of amino acids. In *E. coli*, they each derive part or all of their carbon skeletons from aspartate (21) and share a common biosynthetic pathway, shown in **figure 11**.

Aspartate (21) is phosphorylated to aspartyl phosphate (22) and is then reduced to give aspartic acid β -semialdehyde (ASA) (23). The pathway to

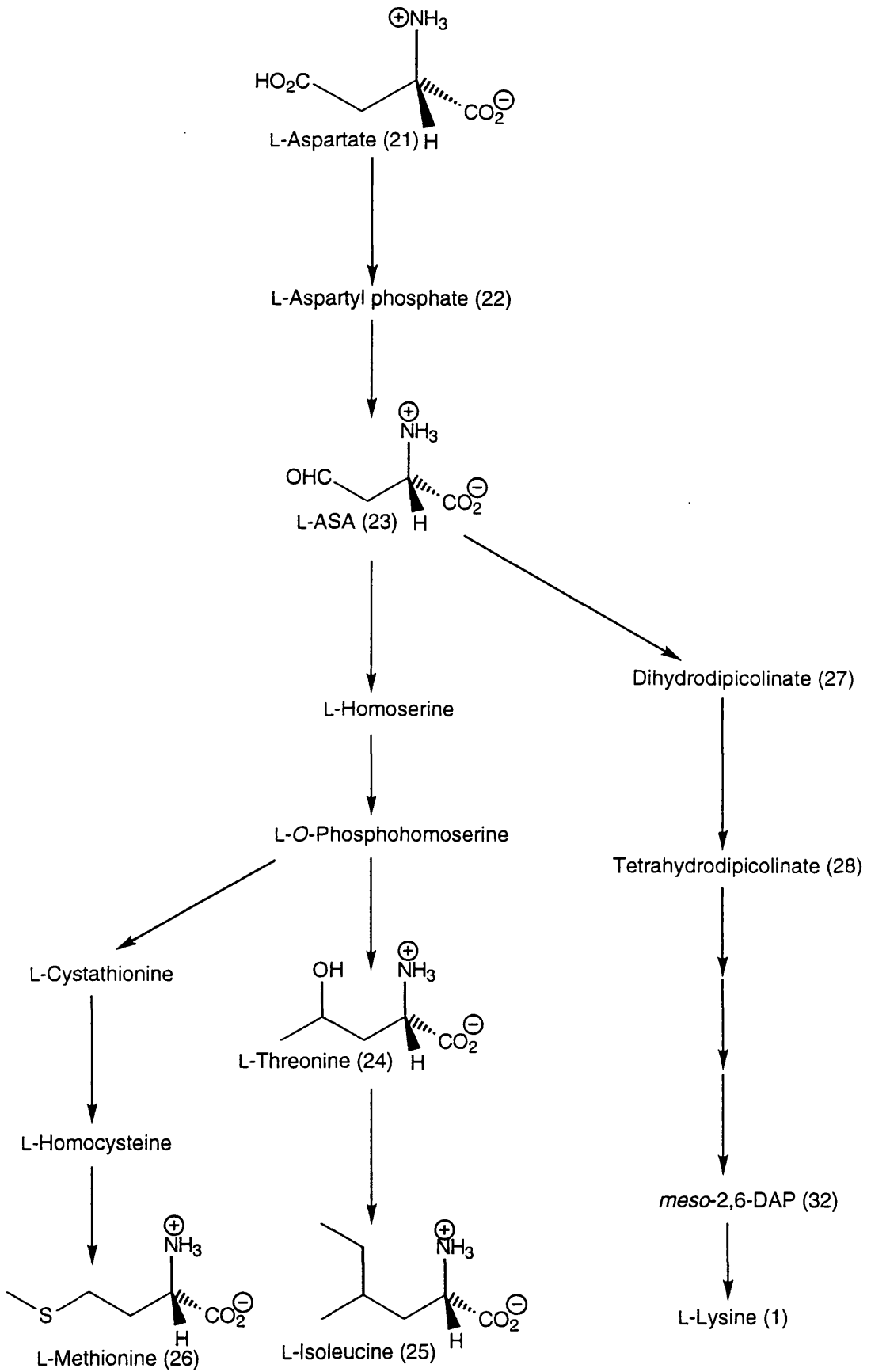


Figure 11: The aspartate family of amino acids

lysine branches at this point with the condensation with pyruvate to form dihydrodipicolinic acid (27). The pathway to the other amino acids in the family continues with the conversion of ASA (23) into homoserine and then *O*-phosphohomoserine. The path to methionine (26) branches at this point with the reaction of *O*-phosphohomoserine with cysteine. The pathway to threonine (24) and isoleucine (25) involves the reduction of *O*-phosphohomoserine to give threonine (24) and then from threonine (24) isoleucine (25) is produced.

In plants and bacteria, lysine (1) is produced via the diaminopimelate pathway⁴⁶ from ASA (23) and pyruvate (32). The pathway requires seven unique steps to transform the initial reactants into lysine (1), shown in **figure 12**. Most of the enzymes of the pathway have been isolated and characterised in *E. coli* and other bacteria. A different story exists in plants where only the enzymes responsible for the first and last transformations have been isolated. Evidence now suggests that the enzymes for the production of lysine (1) are wholly located in the chloroplasts.⁴⁷ This is in accord with current theories of plant evolution which state that the organelles such as the chloroplast are of microbial origin.⁴⁸

The first step in the transformation of ASA (23) into lysine involves the condensation of ASA (23) with pyruvic acid (32). Dihydrodipicolinate synthase catalyses the formation of the new carbon-carbon and carbon-nitrogen bonds to generate the heterocycle 2,3-dihydrodipicolinate (DHDP). The heterocyclic product 2,3-DHDP (27) is reduced to 2,3,4,5-tetrahydrodipicolinate (THDP) (28) by the enzyme dihydrodipicolinate reductase, in an NADH/NADPH dependent fashion. At this point the pathway splits, and two routes exist to lysine (1) in different bacterial species.⁴⁹ The longer pathway proceeds via acylation of THDP (28) using succinyl-CoA. This produces acyl-blocked α -amino- ϵ -ketopimelic acid (29). The ϵ -keto group once free is transaminated by the pyridoxal phosphate dependent transaminase, *N*-succinyl-L,L-DAP aminotransferase. This reaction uses glutamate as the amino donor. The product from this reaction is *N*-succinyl-diaminopimelate (30). Removal of the blocking group by the enzyme *N*-succinyl-L,L-DAP desuccinylase, affords L,L-DAP (31) which is subsequently epimerised by *meso*-DAP epimerase to yield *meso*-DAP (6). This is then decarboxylated at the D-centre using DAP decarboxylase to generate L-lysine (1).

The shorter of the two routes is found in some species of bacteria and plants. *meso*-DAP (6) is produced directly from THDP (28) by means of the enzyme

meso-DAP dehydrogenase. This enzyme requires both ammonia and NADPH for the reaction to take place. The last step of the shorter pathway is exactly the same as for the longer route, namely the decarboxylation of *meso*-DAP (6) by DAP decarboxylase to produce L-lysine (1).

It is known that both routes to L-lysine (1) operate in some species of bacteria including *Corynebacterium glutamicum*,⁵⁰ which is an industrially important producer of L-lysine (1).

The diaminopimelate pathway to lysine (1) will be discussed more fully in chapter two.

1.6: Design of inhibitors of the DAP pathway to L-lysine

Based on the fact that *meso*-diaminopimelic acid (6) is present in and crucial to bacterial cell walls it was natural to assume that inhibitors of the enzymes of the DAP pathway could be powerful anti-bacterial agents.

There are many compounds available which block or interfere with the biosynthesis of bacterial cell walls. These compounds include the β -lactams, which mimic the D-ala-D-ala end of the cross-linking peptide found before the wall is completed. The β -lactams form covalent enzyme-bound products which can take no further part in the biosynthesis of the cell wall peptidoglycan.

Vancomycin is a macrocyclic aminoglycopeptide, found in strains of *Streptomyces orientalis*. It is a broad spectrum antibiotic and is used to treat bacterial infections that have become immune to front line medicines. Its mode of action was discovered to be at the site of cell wall assembly. Vancomycin blocks the later stages of the process by preventing the final attachment of the cell wall to the extracellular acceptors.

Cycloserine is another antibacterial agent which acts at the level of the peptidoglycan cell wall assembly. Cycloserine inhibits the racemisation of L-alanine to generate the D-alanine required for cell wall assembly. The energy required for the cross-linking of the cell wall in the extracellular cavity is provided by the D-ala-D-ala bond cleavage.

There are other reasons why the cell wall synthesis of bacteria has been targeted for research. These include the absence of the pathways in humans and the low toxicity profile this should engender.

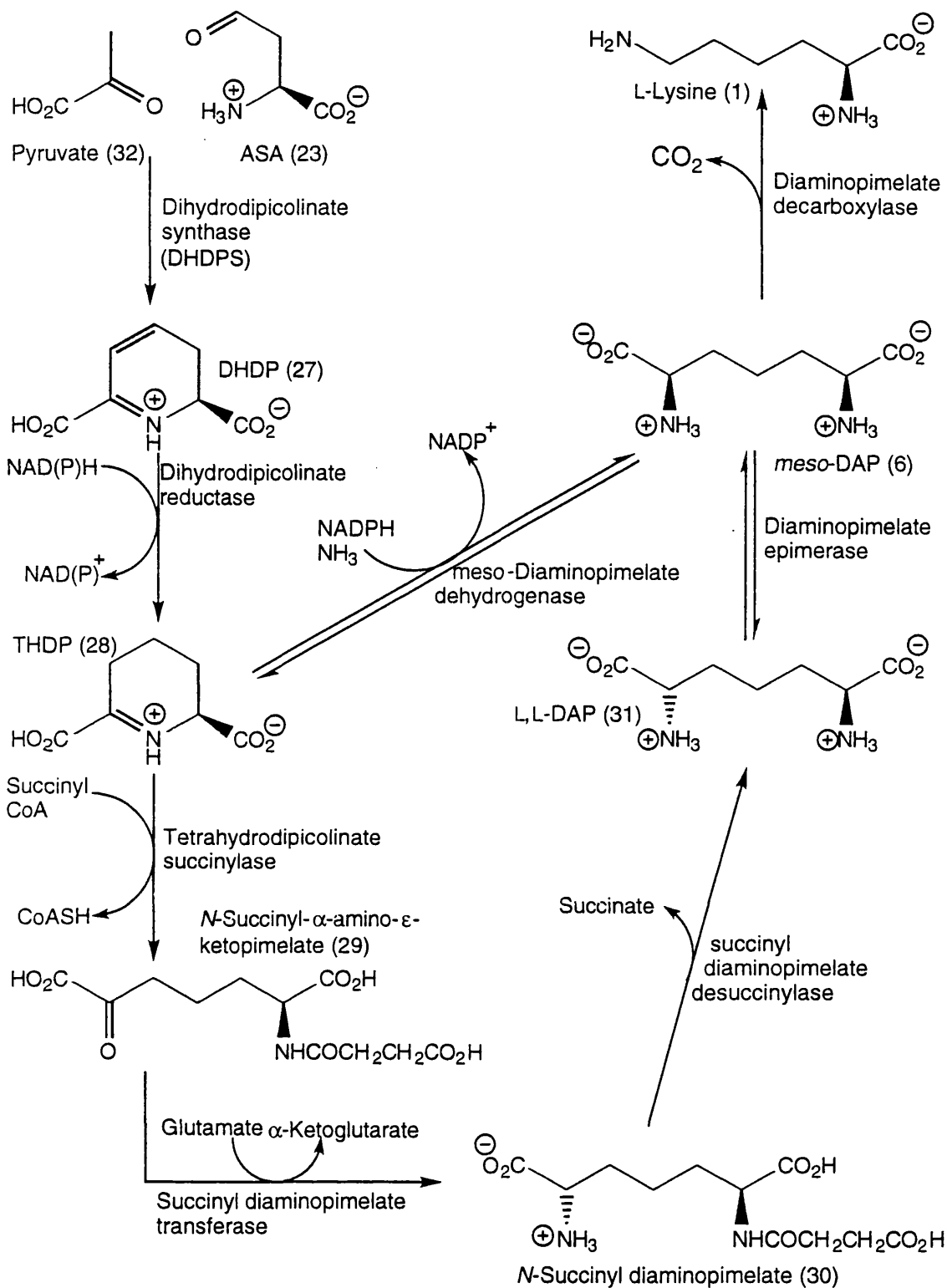


Figure 12: The diaminopimelate pathway to L-lysine

The research in Glasgow has not only concentrated on the design and synthesis of inhibitors but also on the production of substrates. Dr. D. Tudor first synthesised the substrate aspartic acid β -semialdehyde (23) and this will be briefly discussed in chapter 3, along with improvements to the procedure and some derivatives of the ASA skeleton. Dr S. Connell and Dr. L. Couper made a number of analogues of the substrates and products of DHDPS, which

were tested for inhibitory action. Other product analogues including isoxazoles, pyruvates and product-based compounds will be discussed in chapters 4 and 6. Finally the higher homologue of ASA, glutamic semialdehyde, was required to attempt some biotransformations and to find out if it was a substrate for DHDPS. Studies towards this synthesis and the problems it entails will be discussed in chapter 5.

Chapter Two: The Diaminopimelate Pathway to L-Lysine

2.1 Introduction

As discussed in section 1.5 the diaminopimelate pathway (**figure 12**) to L-lysine (1) is found in bacteria and higher plants. In these systems L-lysine (1) is produced by a series of seven enzyme catalysed reactions from L-ASA (23) and pyruvic acid (32). This chapter details the reactions of this pathway and presents a review of the current state of understanding of the reaction mechanisms. To that end, each enzyme will be discussed separately at some length detailing isolation, purification, mechanism and any other relevant information. The research at Glasgow has been focused on the first enzyme of the pathway, namely dihydrodipicolinate synthase and it is with this enzyme that the review below will start. The biosynthesis of L-lysine (1) via the DAP pathway has recently been reviewed.⁵¹

2.2 Dihydrodipicolinate synthase (DHDPS) (EC 4.2.1.52, *dapA*)

This enzyme catalyses the formation of dihydrodipicolinate (27) from L-ASA (23) and pyruvic acid (32) via what is thought to be a multi-step process, see **figure 13**. This condensation marks the first step unique to the biosynthesis of L-lysine (1), and the branch point from the aspartate family of amino acids (**figure 11**).

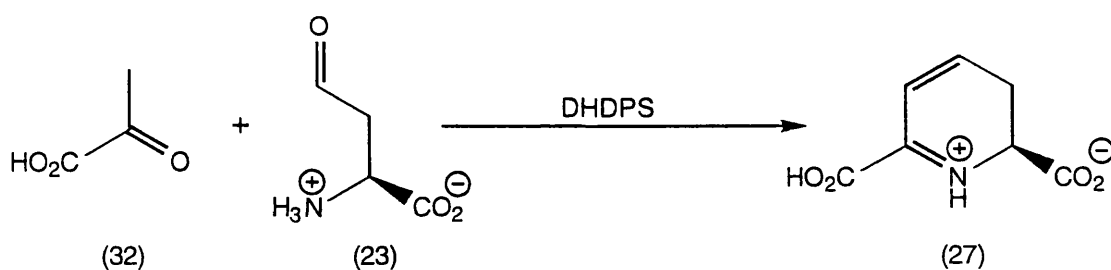


Figure 13: The reaction catalysed by DHDPS.

DHDPS has been characterised from bacteria and a wide range of higher plants including spinach (*Spinacia oleracea*), wheat germ (*Triticum aestivum* L.), and maize seedlings (*Zea mays* L.), and has been highly purified from wheat cell suspension cultures and tobacco leaves (*Nicotiana glauca*). The complete amino acid sequences of DHDPS from *E. coli*, *Corynebacterium glutamicum*, wheat and maize have been reported.^{52,53} These enzymes have been shown to exist as homotetramers, composed of four identical subunits.

The first preparation of *E. coli* DHDPS to achieve a high degree of purification was carried out by Shedlarski and Gilvarg.⁵⁴ They achieved a purification of over 5000 fold from crude cellular extracts of *E. coli* W. They were able to study the enzyme and found that it was indeed a homotetramer comprising of four identical subunits. They determined the molecular weight of the protein monomer to be 33,000 by SDS polyacrylamide gel electrophoresis.⁵⁵ The amino acid sequence was determined by degradation experiments it was discovered that the amino acid methionine was absent from the protein. They demonstrated that the protein was homogeneous by gel electrophoresis and that it bore a negative charge in the pH range 6.0-9.2. The nucleotide sequence of the *dapA* gene locus⁵² predicts that the molecular weight of the protein produced from that gene sequence should be in the region of 31,372. The molecular mass of the native protein was estimated by the more gentle technique of gel permeation chromatography. The molecular weight obtained by this technique was 134,000 giving good evidence for the existence of DHDPS as a tetramer in its native form.⁵⁴⁻⁵⁶

In 1975, Cheshire and Mifflin reported a partial purification of DHDPS from maize (*Z. mays* L.).⁵⁷ Mazelis and co-workers reported the detection of DHDPS activity in a range of monocotyledonous and dicotyledonous species including corn, beansprout, cabbage, spinach leaf, potato tuber and squash fruit. They further succeeded in partially purifying DHDPS from wheat germ.⁵⁸ Wallsgrave and Mazelis obtained partially purified DHDPS from spinach leaves (*S. oleracea* L.) by chromatography and gel filtration.⁵⁹ They determined the molecular weight to be 115,000. The DHDPS of spinach leaves was found to be localised in the chloroplast where the pH optimum of the enzyme was discovered to be 8.2. This is close to the actual pH found inside the chloroplast.⁶⁰ DHDPS was purified 5100 fold from suspension cultured cells of wheat (*Triticum aestivum* var. Chinese spring) by Kumpaisal and co-workers in 1987.⁶¹ An average molecular weight of the native wheat enzyme was found to be 123,000 by gel filtration experiments. A subunit molecular weight of 32,000 was determined. The enzyme exhibited maximum activity close to pH 8.0.

Ghislain and co-workers⁶² isolated and characterised DHDPS from *N. sylvestris*. The synthase was found to be located in the chloroplasts but they also identified a soluble stroma enzyme by enzymatic and immunological methods. The molecular weight of the DHDPS they isolated was found to be 164,000. They carried out a series of experiments with isotopically labelled ¹⁴C-pyruvate and were able to determine that the enzyme was composed of four identical subunits with a molecular weight of 38,500.

A more recent isolation of the enzyme was reported by Frisch and co-workers.⁶³ They isolated DHDPS from maize leaves (*Z. mays L.*) and obtained a 30,000 fold purification. They determined the molecular weight of the maize enzyme homotetramer to be 130,000. By SDS-PAGE they found that the subunit molecular weight was 38,000.

DHDPS which may be of a different origin was reported by Schar and co-workers.⁶⁴ They purified DHDPS to homogeneity from pea (*Pisum sativum*), and found that the pea DHDPS was a homotrimer of native molecular weight 127,000. The subunit molecular weight was found to be 43,000. The evidence for the different origin of this enzyme was that it contained 22 moles of methionine per mole of native protein. The *E. coli* enzyme contains no methionine in its amino acid content. The initial stage of the mechanism, however, was found to be the same, namely the formation of the Schiff's base between pyruvic acid (32) and the enzyme.

2.3 Purification of DHDPS

Protein purifications generally involve the use of chromatography. The crude protein mixture is loaded onto a material which is designed to bind proteins to different degrees. This allows the mobile phase to separate the various proteins by virtue of the different relative retention times in each phase. These materials are generally polymeric materials with a group attached designed to attract or repulse proteins.

Many materials are available making use of the wide-ranging properties of proteins. The simplest are gel filtration, where the holes in the material are of a fixed size and proteins larger than the holes flow through the column quickly. Proteins smaller than the holes are retarded and their progress through the column is slowed. Ion exchange chromatography is based on the attraction of opposite charges. Proteins contain many positive and negative charges on their surface and the net charge is either positive or negative. Two types of gel are available, namely anion and cation exchangers. The proteins are removed from the column by increasing the ionic concentration of the eluant. Many materials are marketed; two of these are diethylaminoethyl (DEAE) sephacel which is an anion exchanger and carboxymethyl (CM) sephacel.

Other types of purification techniques used are based on affinity and hydrophobic interactions. All proteins contain hydrophobic and hydrophilic

groups on the surface, and it is usual for the hydrophilic groups to dominate over hydrophobic for cytosolic proteins. The balance that exists between the two is exploited by hydrophobic interaction columns. A more powerful technique is that of affinity chromatography. A group is attached that is bound strongly by a specific protein and this is used to bind the protein tightly onto the column while the rest of the undesired proteins are washed away. The protein is removed by an increasing concentration of the ligand it specifically binds free in the eluant, or simply by increasing the salt concentration. Examples of these techniques are outlined in **figure 14**.

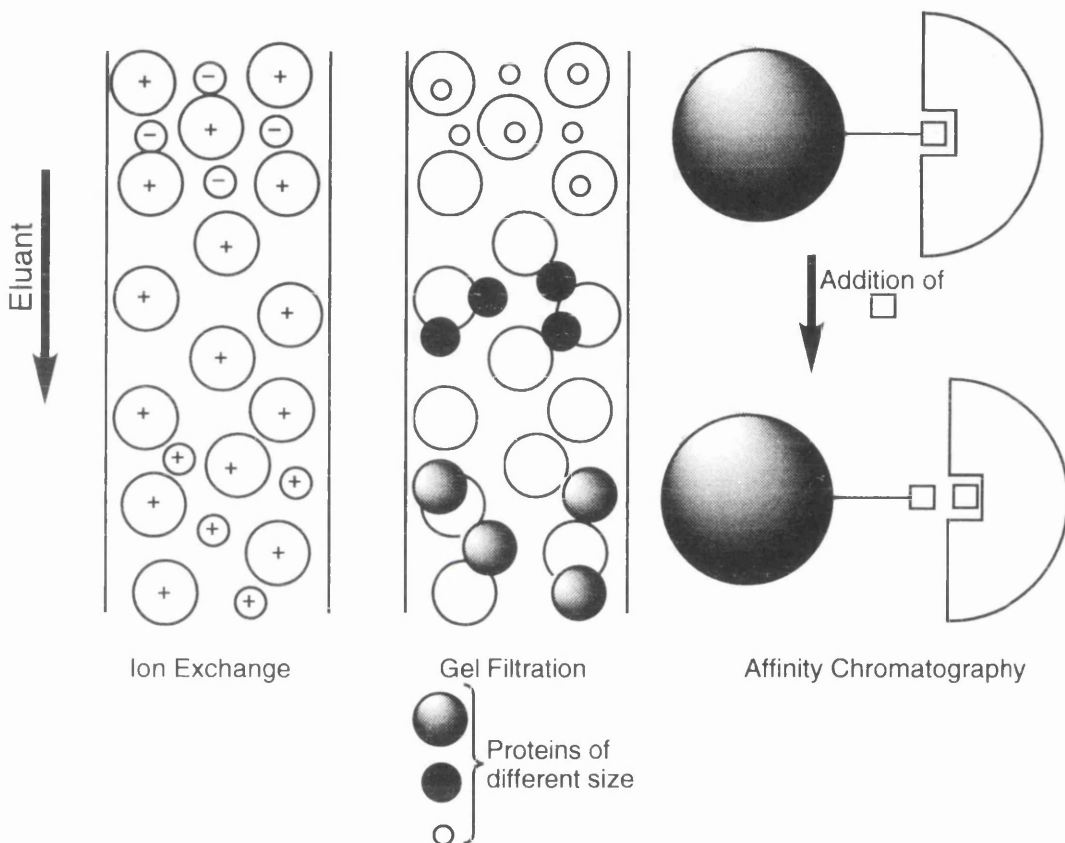


Figure 14: Protein chromatographic techniques.

The various purifications of DHDPS have utilised all of these techniques to purify the enzyme to homogeneity. Schar and co-workers⁶⁴ utilised 2-aminoethyl-L-cysteine bound to Eupergit resin as an affinity column in their procedure to purify pea DHDPS. Gengenbach and co-workers⁶³ used a phenyl sepharose chromatographic step to purify the DHDPS from maize cell suspensions. Ghislain *et al.*⁶² utilised a DEAE sephacel chromatographic step to aid the purification of DHDPS from *N. sylvestris* by a factor of 163 fold.

At Glasgow, Borthwick⁵⁵ developed a purification for DHDPS from *E. coli* cells. The initial purification was developed from wild type *E. coli* cells and then from

an overproducing strain of *E. coli* (MV1190/pDA2). The purification involved a total of three chromatographic steps and gave a purification of 49 fold. The chromatographic steps were DEAE sephacel followed by a phenyl sepharose step and finally after concentration a Mono-Q FPLC column.

2.4 Characterisation of DHDPS

There have been three assays developed to detect the presence of DHDPS activity. The first is based on the absorbance of an unidentified adduct of L-DHDP (27) with *o*-aminobenzaldehyde. The reaction is monitored spectrophotomerically at 540 nm. A second assay is based on the first and second steps of the pathway and is a coupled assay. This relies on both DHDPS and DHDPR. The product of this process will be L-THDP (27), itself unstable under the conditions used. The process is monitored by following the reduction in absorbance due to NAD(P)H being utilised. The most useful assay for the reaction catalysed by DHDPS is to monitor the increase in absorbance due to dipicolinic acid (33) formed by a spontaneous oxidation of L-DHDP (27) under the assay conditions (figure 15).

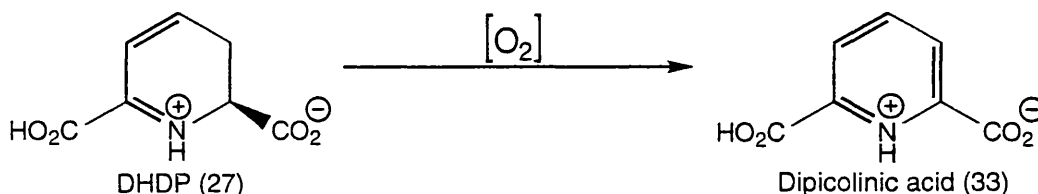


Figure 15: The basis for the DHDPS activity assay at 270 nm.

Utilising one or more of these assay methods has enabled groups to study DHDPS from many sources and gather a large amount of detail on the behaviour of the enzyme. As was stated earlier (section 2.2) the pH optimum for the reaction is about 8. A great deal of work was undertaken to determine the K_m for the two natural substrates of DHDPS. The K_m for ASA (23) varies between 0.4 mM and 3.1 mM whereas the K_m for pyruvic acid (32) is higher, about 0.5 mM to 11.8 mM. Kinetic analysis of the reactions catalysed by *E. coli*,⁶⁵ wheat⁶¹ and maize (*Z. mays*)⁶³ suggests that in the enzymic reaction pyruvate (31) is bound with the loss of water, followed by binding and reaction of ASA (23). It has been shown that the *E. coli* DHDPS displays Ping Pong BiBi kinetics.^{54,56,61}

2.5 Determination of the molecular weight of DHDPS from *E. coli*

The purification procedure developed by Borthwick⁵⁵ was used to obtain samples of *E. coli* DHDPS for electrospray mass spectrometry. This is a gentle, but highly accurate technique for the measurement of the molecular mass of DHDPS.

Electrospray mass spectrometry makes use of the polycharged nature of proteins. The protein must first be made wholly positive or negative for the technique to work. This is achieved by adding 0.2% formic acid or 0.2% ammonia to a solution of the protein. This is then injected into the mass spectrometer and is carried into the probe by a carrier gas, usually heated nitrogen. Upon spontaneous evaporation of solvent, the polycharged species are then accelerated by a potential difference and crash into the detector. The detector measures a mass/charge ratio for each species and from the peaks detected can calculate the mass of the protein. A diagram of the electrospray mass spectrometer is shown in figure 16.

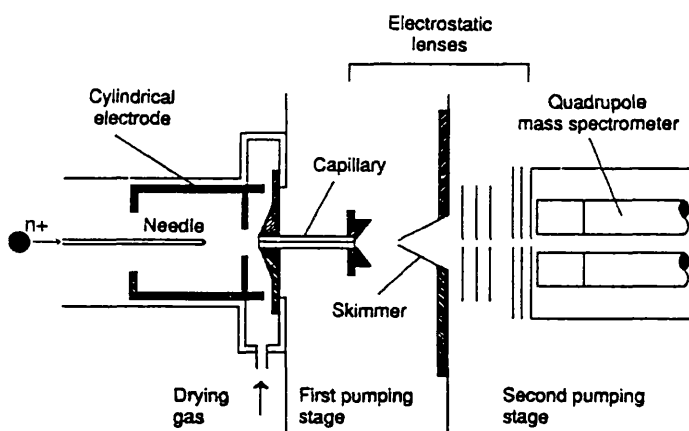


Figure 16: An electrospray mass spectrometer.

It was found by Borthwick *et al.*⁶⁶ that the *E. coli* enzyme they were studying had a molecular weight of 31,272 per subunit as shown in **figure 17**. This however was found to be 100 daltons higher than the DNA sequence from the *dapA* gene would suggest. It was discovered by doing a series of tryptic digest experiments that there was an error in the protein sequence. It was made known to Coggins by Laber (personal communication) that one of the three glutamic acid residues in the digest containing residues 220-230 in the protein was in fact a glycine. This lowered the mass discrepancy to 28 daltons. It was noted by Coggins that the electrospray mass spectrometry showed no sign of impurities and that there must be a second error in the sequence of the *E. coli* DHDPS protein.

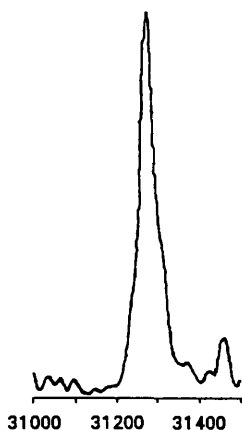


Figure 17: Electrospray measurement of the mass for DHDPS from *E. coli*.

2.6 The mechanism of DHDPS

The sequence of steps that converts L-ASA (23) and pyruvic acid (32) into L-2,3-dihydrodipicolinate (27) has not been fully investigated and elucidated. It is however known that pyruvic acid (32) binds to the enzyme via the ϵ -amino group of a lysine residue (Lys 161).^{54,56,61} There are two theoretically possible pathways by which the reaction can proceed. One pathway involves the formation of the new C-C bond between the aldehyde group of L-ASA (23) and the bound pyruvic acid (32) to produce an enzyme-bound intermediate (34). Ring closure of the enzyme-bound intermediate requires release from the enzyme to liberate the 4-hydroxy-L-2,3-dihydrodipicolinate (35), see **figure 18**. The loss of a mole of water, probably while within the enzymes active site, then completes the synthesis of L-DHDP (27).

The evidence to support the first enzyme-bound/activated pyruvate adduct is quite substantial. The enzyme is known to be inactivated when pyruvate incubation is followed by addition of sodium borohydride.⁵⁴ We have taken this a stage further and have direct evidence for the Schiff's base and for the reduced imine, formed by sodium borohydride reduction of the Schiff's base, covalently bound to the then inactivated enzyme. **Figure 19** shows the ESMS for one mole of pyruvate bound to DHDPS. The ESMS work will be discussed further in chapter 7.

The second mechanism, and the less likely is that shown in **figure 20**. This involves imine formation as the first step of the reaction with the ring closure happening free from the enzyme or whilst still bound to the enzyme.

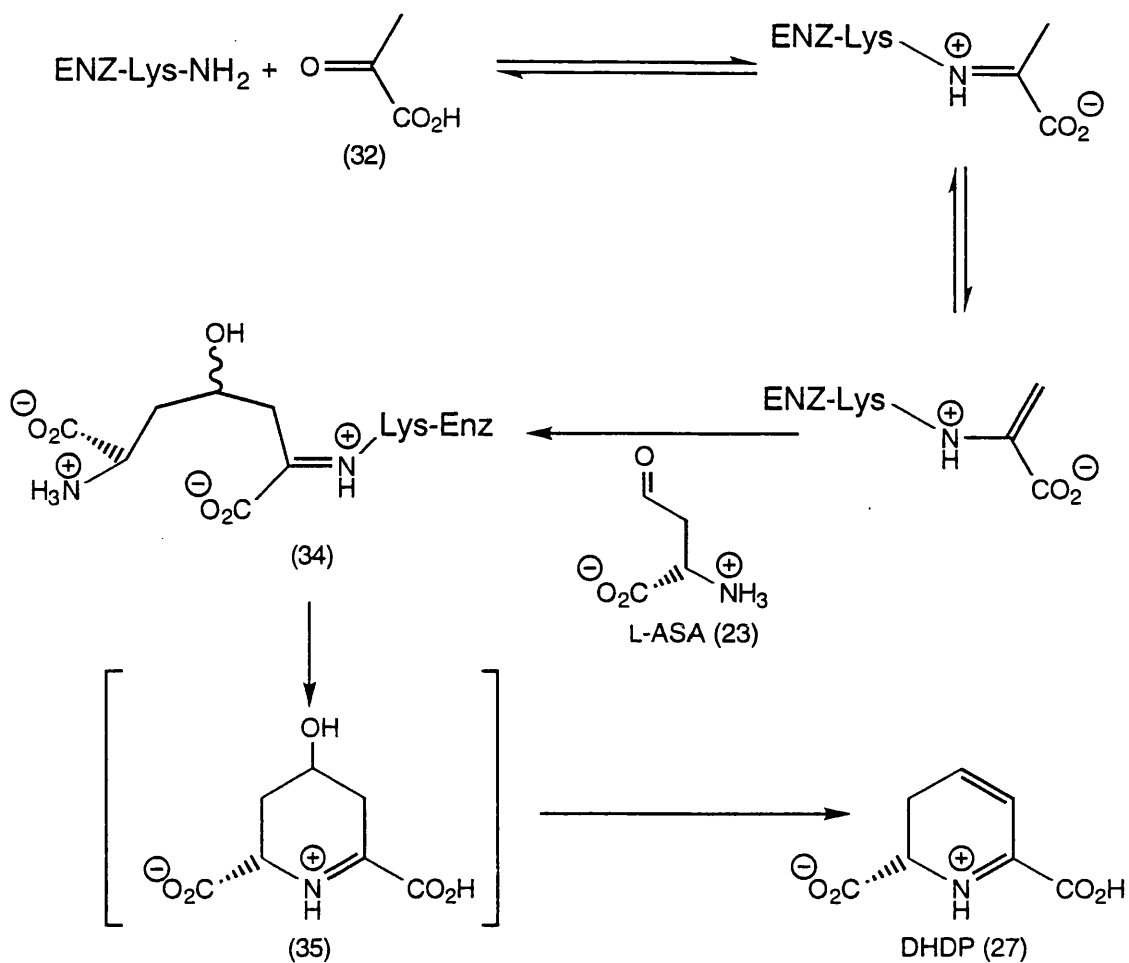


Figure 18: Formation of DHDP (27) via an enzyme bound intermediate

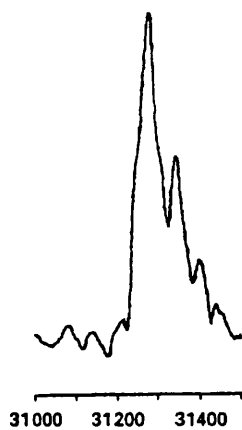


Figure 19: ESMS for pyruvate bound to DHDPS via a Schiff's base

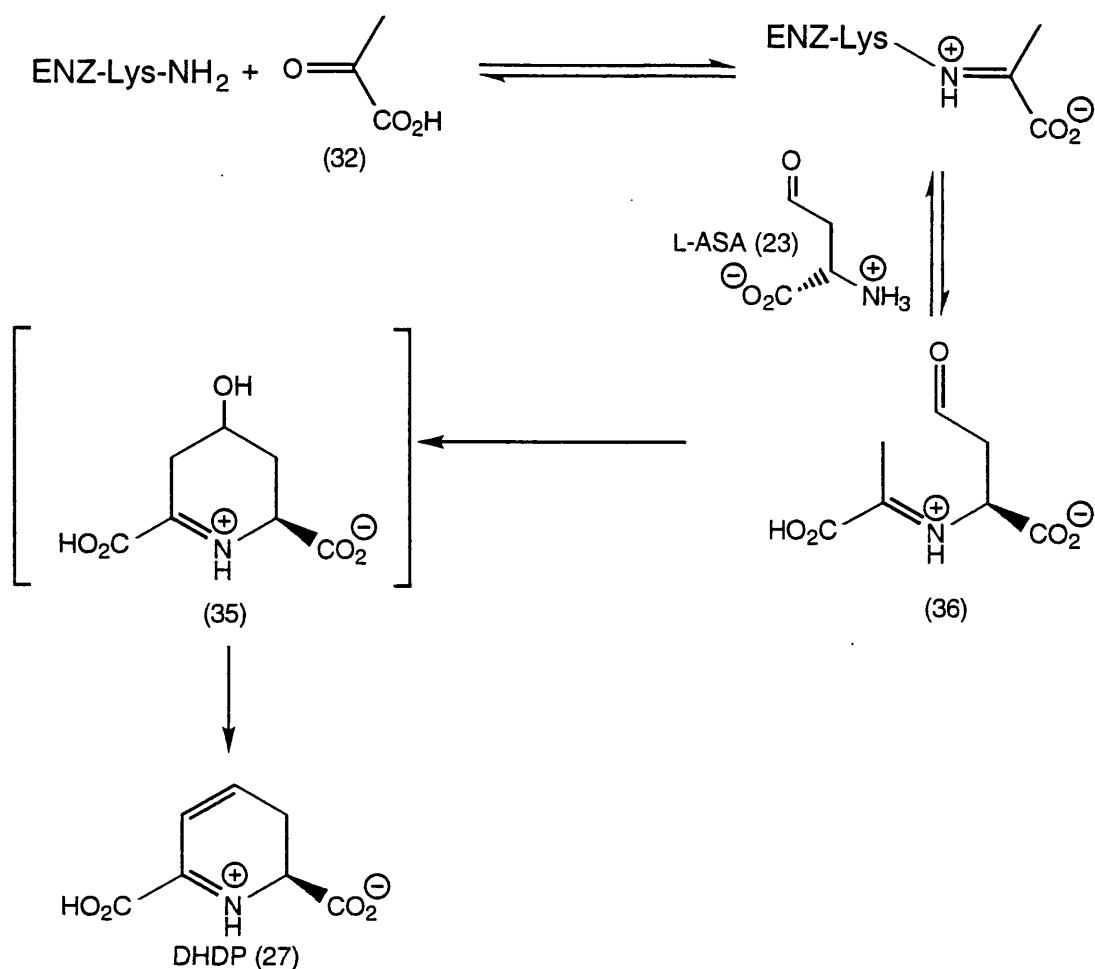


Figure 20: Formation of DHDP (27) via an enzyme free ring closure.

Intermediate (36) is free from the enzyme, although it may still be in the active site of the enzyme when ring closure occurs. Loss of the elements of water will again give L-DHDP (27) as the product.

This reaction catalysed by DHDPS is similar to that carried out by a number of aldolases. It is very common for aldolase reactions to proceed via a Schiff's base intermediate bound to the ε-group of a lysine residue.⁶⁷

2.7 Crystal structure of *E. coli* DHDPS

The *E. coli* enzyme has been crystallised and a crystal structure at 2.5 Å resolution was obtained.⁶⁸ It was discovered that the active site lysine (Lys 161) is at the bottom of a cavity 10 Å deep by 30 Å long. It is possible for the pyruvate substrate to approach the lysine residue through an entrance formed by adjacent aspartate residues (Asp 187 and 188). These two residues are conserved in all known DHDPS enzymes, and this is taken as an indication that these two residues are important. It is possible that they have a mechanistic

role; presumably this would be general acid/base catalysis. **Figure 21** shows part of the crystal structure showing the active site buried below the opening.

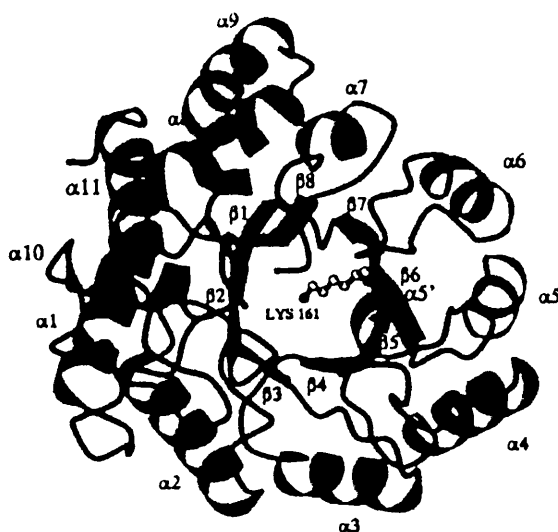


Figure 21: The active site of *E. coli* DHDPS

2.8 Inhibition and regulation of DHDPS

Numerous studies of substrate analogues and inhibitors have been carried out. The enzyme displays high specificity for its substrates. For the *E. coli* enzyme pyruvate (32) analogues such as phosphoenolpyruvate, phenylpyruvate, α -ketobutyrate, oxaloacetate and fluoropyruvate are not recognised as substrates. Analogues of ASA (23) such as *N*-acetyl-ASA and succinate semialdehyde are also not substrates.⁶⁹ It was found by Robins and co-workers⁷⁰ that D-ASA was not a substrate of the *E. coli* enzyme and that it did not show any inhibition. Bromopyruvate was found to alkylate DHDPS and caused inhibition (K_i 1.6 mM for *E. coli* and 1.8 mM for wheat).⁷¹ Alkylation may be near or at the active site for the wheat enzyme, as it was found that high concentrations of pyruvic acid (32) would protect the enzyme. For the *E. coli* enzyme alkylation is not at the active site. Studies by Coggins and co-workers⁶⁶ showed that the *E. coli* enzyme was monoalkylated when four equivalents of bromopyruvic acid were added, see **figure 22**. Peaks corresponding to imine formation with Lys 161 were not detected by electrospray mass spectrometry. It was also found that the monoalkylated enzyme retained 72% of its activity. This suggests that the alkylation is near but not at the active site of the enzyme. Significant inhibition was seen on polyalkylation with a large excess of bromopyruvate.

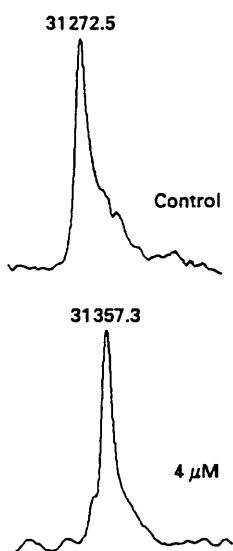


Figure 22: ESMS of DHDPS treated with four equivalents of bromopyruvic acid

Acetopyruvate (37), **figure 23**, was found to be an effective slow binding inhibitor for *E. coli* DHDPS with a K_i of $5 \mu\text{M}$.⁷² A drop in the effectiveness of this inhibitor was discovered when the pH was raised above 8. It is unclear which of the possible tautomers is the active compound. It may be the diketone (37) or the structures shown as (38a) or (38b) may act as inhibitors because they mimic elements of both substrates, and the proposed reaction intermediate.

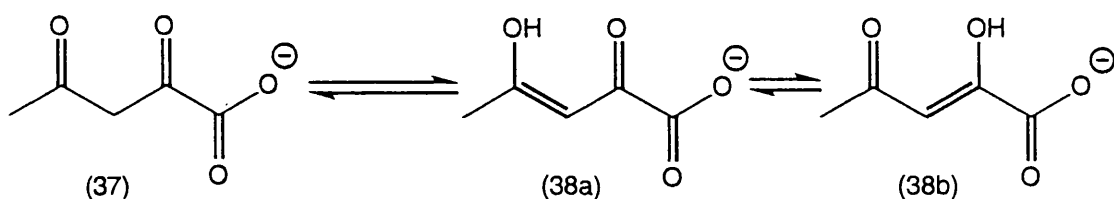


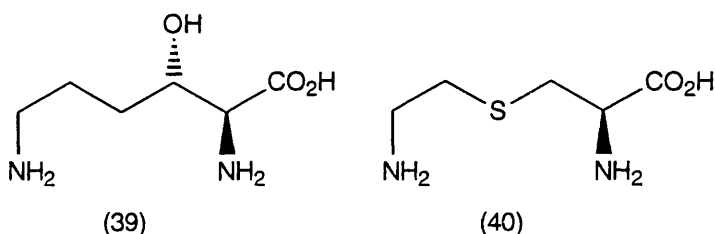
Figure 23: Acetopyruvate (37) and its tautomers (38a and b)

For plants and some bacterial enzymes the final product of the DAP pathway, lysine (1), is regulatory. In *E. coli* and wheat DHDPS, the enzymes are inhibited weakly by lysine (1). L-Lysine (1) is a non-competitive inhibitor with respect to pyruvate (32), and inhibits competitively with ASA (23) for these enzymes. In *E. coli* and *Bacillus sphaericus*, L-lysine (1) inhibition is weak⁷³ (IC_{50} *E. coli* 1 mM and *B. sphaericus* 0.6 M). Such inhibition by L-lysine (1) has not been observed in other bacterial strains.⁷⁴ Plant DHDP synthases show potent allosteric inhibition by L-lysine (1) with IC_{50} values as shown in **table 2**.

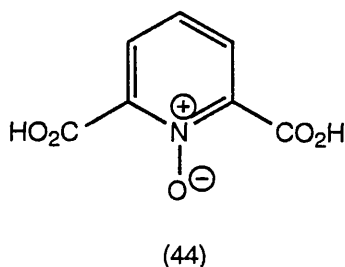
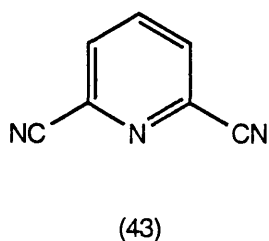
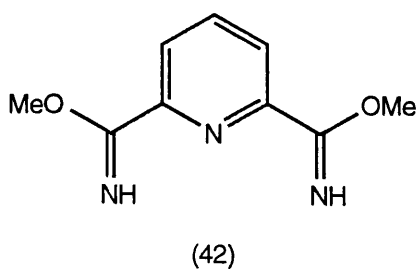
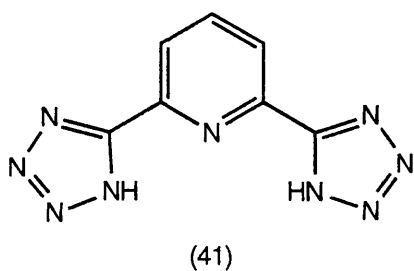
Plant	IC ₅₀ for inhibition by lysine (μM)
wheat germ ⁵⁸	11
tobacco ⁶²	15
spinach ⁵⁰	20
maize ⁶³	23
wheat ⁶¹	51

Table 2: IC₅₀ values for allosteric inhibition of DHDPS by lysine

Analogues of L-lysine (1) show similar patterns of activity, but these are somewhat less effective; for wheat, *threo*-β-hydroxy-L-lysine (39) is inhibitory with an IC₅₀ of 141 μM, as is (2-aminoethyl)-L-cysteine (AEC) (40) with an IC₅₀ of 288 μM.⁶¹ Other plant DHDPS enzymes show similar patterns of inhibition for instance AEC (40) inhibits DHDPS from tobacco⁷⁵ with an IC₅₀ of 120 μM, and the enzyme from spinach with an IC₅₀ of 400 μM.⁵⁰

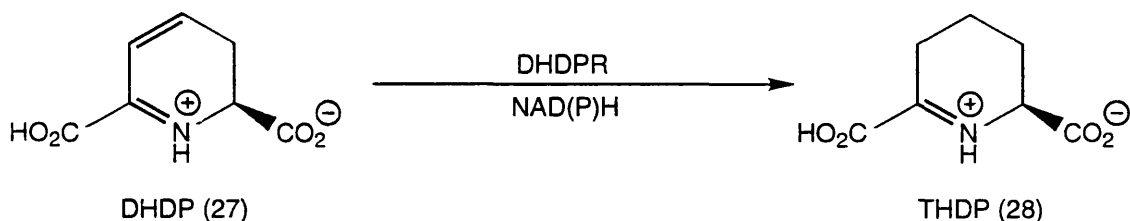


Dipicolinic acid (34) inhibits the *E. coli* DHDPS with an IC₅₀ of 1.2 mM.⁵⁶ This prompted a systematic investigation of numerous heterocyclic analogues of both dipicolinic acid (34) and DHDP (27) by our group in Glasgow.⁷⁶ Substituted pyridine and piperidine derivatives were found to be moderate inhibitors with IC₅₀ values of less than 1 mM. The best of the inhibitors were a ditetrazole (41), diimidate (42), dinitrile (43) and the *N*-oxide of pyridine-2,6-dicarboxylic acid (44). Detailed kinetic studies were carried out (see chapter 7) and it was found that compounds (43) and (44) were non-competitive inhibitors with respect to either substrate. Out of the systematic study it was discovered that esters were stronger inhibitors than their acid congeners and that a planar distribution of the substituents was preferred around the nitrogen atom.



2.9 Dihydrodipicolinate reductase (DHDPR) (EC 1.3.1.26, *dapB*)

Dihydrodipicolinate reductase catalyses the pyridine nucleotide dependent reduction of dihydrodipicolinate (DHDP) (27) to tetrahydrodipicolinate (THDP) (28), see **scheme 24**.



Scheme 24: The reaction catalysed by DHDPR

2.10 Isolation of DHDPR

DHDPR was first isolated from *E. coli* by Farkas and Gilvarg.⁷⁷ Tamir and Gilvarg⁷⁸ succeeded in purifying the protein to homogeneity. A molecular weight of 110,000 was calculated for the enzyme. Also reported was the K_m for L-DHDP (27), 9.0 μM , and the pH optimum which was found to be 7.0. The enzyme, somewhat unusually, can utilise both NADH and NADPH as a cofactor.

DHDPR has also been isolated from *Bacillus cereus* and *B. megaterium*.⁷⁹ The enzyme was purified 100 fold from crude extracts of these organisms. The proteins isolated proved to be homotetramers with molecular weights of 155,000 and 150,000, respectively. The reductases were inhibited non-

competitively with respect to L-dihydrodipicolinic acid (27) by dipicolinic acid (33), with K_i values of 85 μM and 140 μM , respectively.

The reductase enzyme has also been isolated from maize kernels by Tyagi *et al.*⁸⁰ Both the crude extracts and the partially purified extracts were assayed for DHDPR activity and for their ability to restore the reductase capability to crude extracts of mutant *E. coli* (defective in DHDPR). The restoration was monitored by following the production of *meso*-2,6-diaminopimelic acid (6). The enzyme was studied in detail and was found to have a molecular weight of 80,000. The K_m value for L-DHDP was found to be 0.43 mM and for NADPH the K_m value was 46 μM . The pH optimum of the enzyme was close to 7.0 but the enzyme was found to be more temperature labile than the *E. coli* reductase.

DHDPR activity has also been detected in *Chlamydomonas*, corn, soybean and tobacco.⁸¹

2.11 Assay systems for DHDPR activity

Two assays have been described utilising synthetic DHDP (27). This material is stable only if stored under basic conditions at $\text{pH} > 10$. The two methods of preparing DHDP (27), one enzymic and the other chemical, were reported by Shedlarski and Gilvarg⁵⁴ and by Tyagi *et al.*⁸⁰

Shedlarski and Gilvarg suggested that L-2,5-DHDP (45) could be the product of the pyruvate/ASA condensing enzyme and that this product could be in equilibrium with L-DHDP (27) and L-4-hydroxy-3,4,5,6-tetrahydrodipicolinic acid (46), see **figure 25**. It is not clear which of these compounds is the immediate product of the enzymatic condensation.

Tyagi *et al.*⁸⁰ described a chemical synthesis of L-DHDP from the condensation of L-ASA (23) and oxaloacetic acid (47) in alkaline solution, see **figure 26**. L-DHDP was precipitated as its barium salt. The compound was unstable and was stored at $-80\text{ }^\circ\text{C}$. Only freshly prepared samples were used in assays.

The third assay procedure described makes use of the decrease in absorbance, at 340 nm, as NAD(P)H is used up during the course of the reaction.⁵⁴

2.12 Mechanism of DHDPR

A detailed study of the mechanism of DHDPR was carried out by Reddy *et al.*⁸² They produced an overexpressing strain of *E. coli* which they used to isolate the *dapB* gene, enabling them to generate large quantities of enzyme required for the mechanistic study.

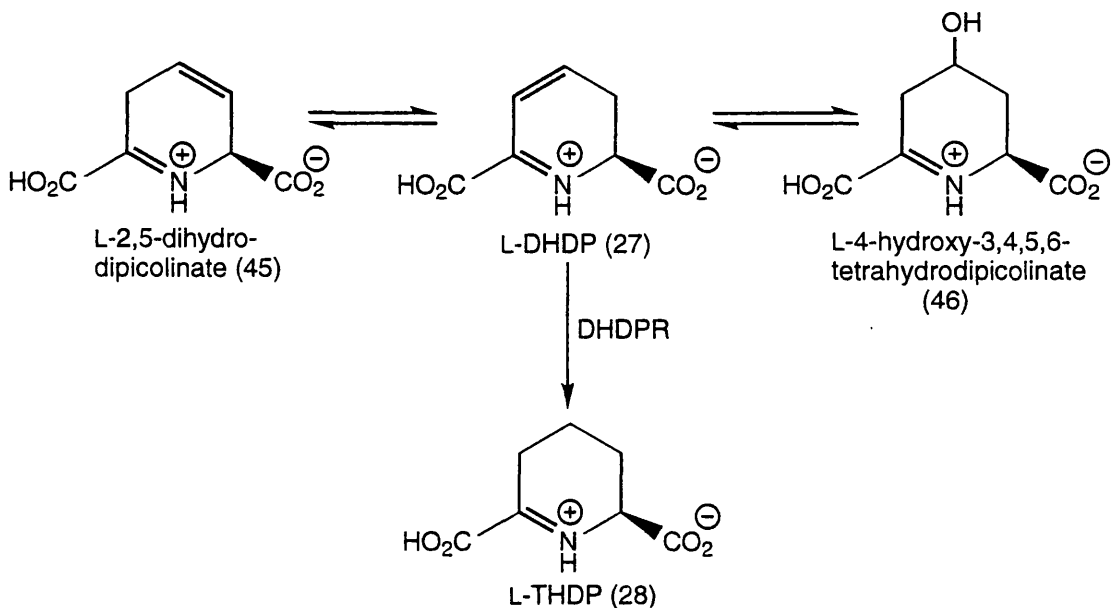


Figure 25: Enzymic production of L-DHDP for use in an assay system

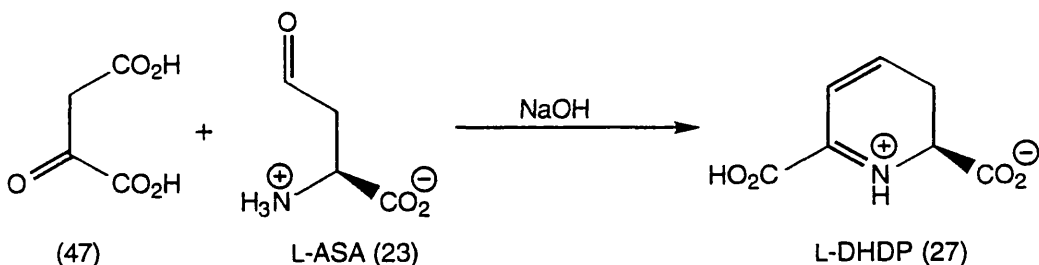


Figure 26: Chemical synthesis of L-DHDP for assay systems

Reddy *et al.*⁸² found that the cofactor duality was indeed present and that NADH was the better cofactor with a K_m (1.6 μM) approximately four times lower than that obtained for NADPH (5.6 μM). This is remarkable because it was discovered that when NADPH was used the rate of reaction was more than twice that observed when NADH was used (V_{rel} 100 for NADPH and 62 for NADH).

Reddy *et al.*⁸² had previously proved that NAD(P)H donates its *pro-R* hydrogen to DHDP (27) by means of tritium labelling studies. They then chose to investigate the position of hydride addition to DHDP (27). They used deuterium labelled NADH for the reduction and then carried the reaction product through

to *meso*-DAP (6), using *meso*-DAP dehydrogenase, see **figure 27**. They used [2-D]malate (48) as part of a regeneration system for NADPD for both reactions. The enzyme malic enzyme regenerates NADPD and converts malate into pyruvate and carbon dioxide. It is known that *meso*-DAP dehydrogenase transfers its *pro*-S hydrogen to the substrate to form the D-stereocenter. This generated a dideuterated *meso*-DAP (49). The 500 MHz ^1H NMR spectrum confirmed the donation of the *pro*-R hydrogen of NADPD to the 4-position of DHDP (27), see **figure 28**.

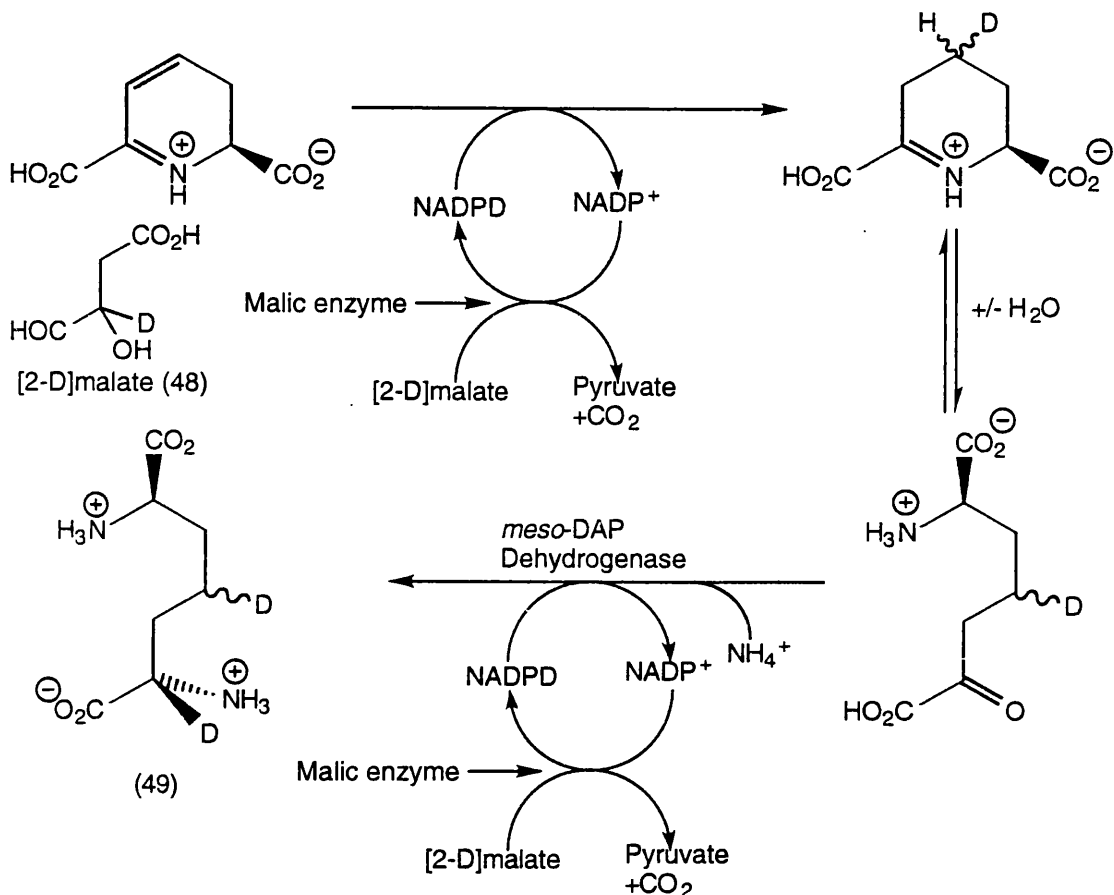


Figure 27: Investigation of the mechanism of DHDPR

Figure 28 shows the the ^1H NMR spectrum (A) of the unlabelled *meso*-DAP (49a) and the ^1H NMR spectrum (B) of the dideuterated *meso*-DAP (49b). The changes are that the signal at δ 1.83 disappears. This is due to the action of DHDPR on L-DHDP (27) and the signal is reduced at δ 4.35 from integrating for two protons to integrating for one proton. No attempt was made to distinguish the two C-4 proton signals to determine the face of the deuterium delivery onto L-DHDP (27). Thus the mechanism for DHDPR can be illustrated as seen in **figure 29**. The 4-R hydride is transferred from the cofactor to the β -position of the $\alpha\beta$ -unsaturated immonium ion (nothing is known about the face of delivery),

generating the enamine. Enzyme assisted protonation then completes the reduction and THDP (28) is released from the enzyme.

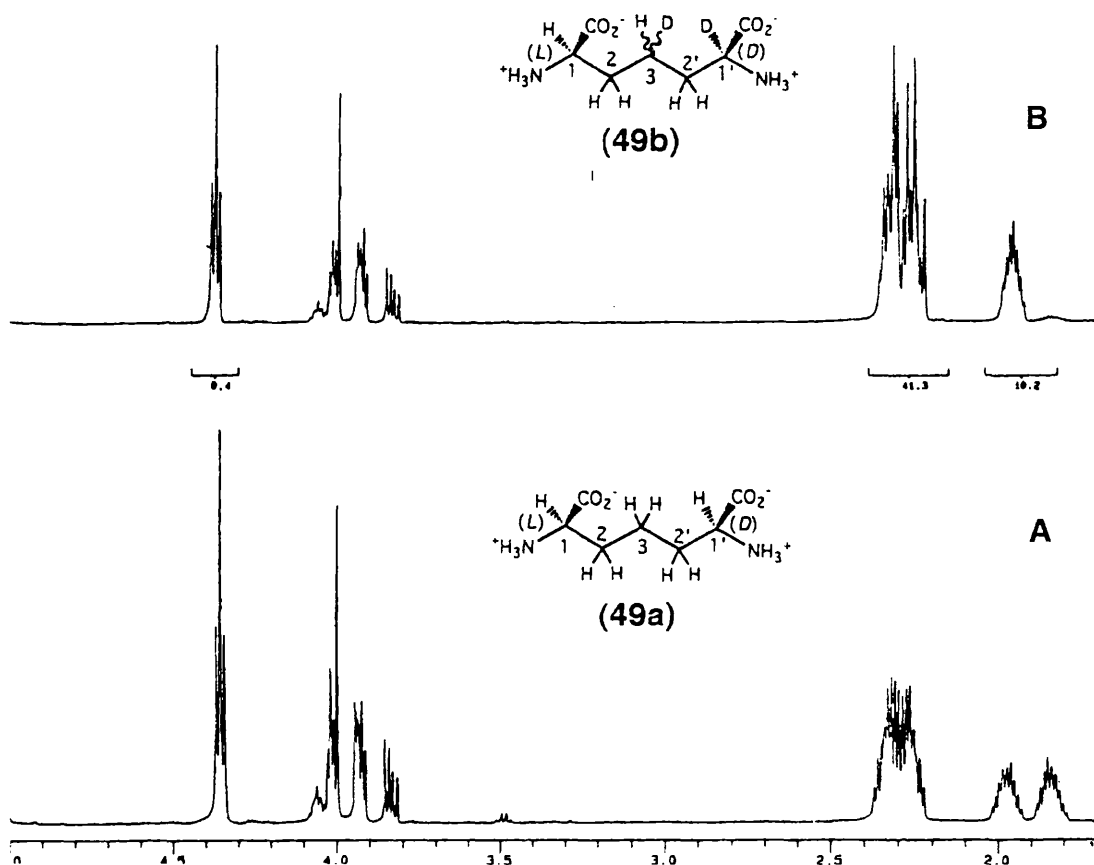


Figure 28: 500 MHz NMR spectrum of the isolated products from DHDPR mechanistic studies⁸²

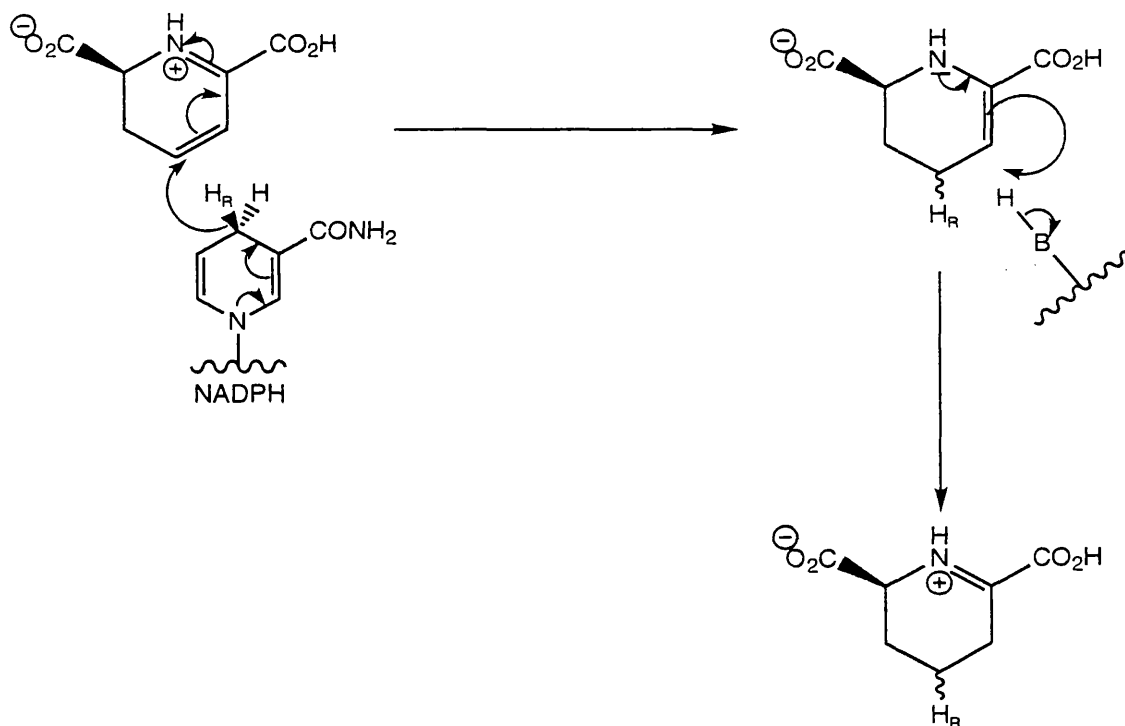


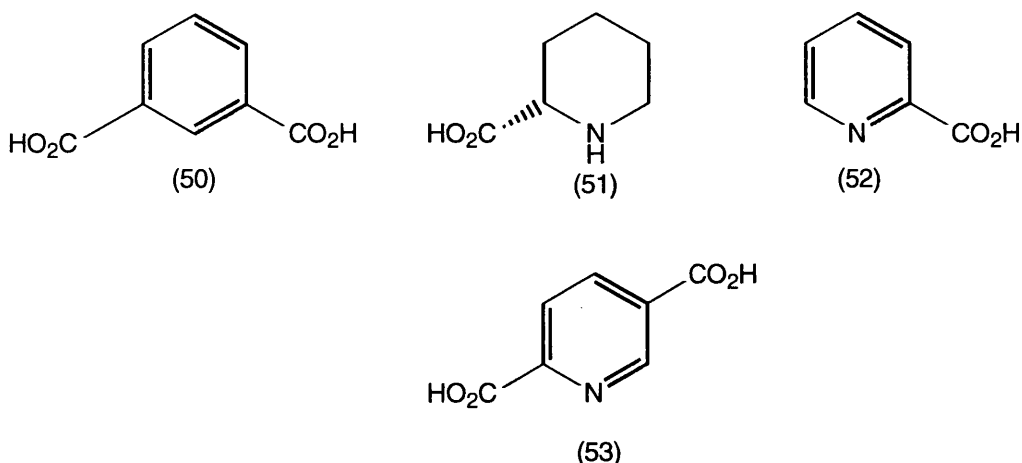
Figure 29: Proposed mechanism for DHDPR

2.13 Crystal structure of DHDPR

A crystal structure at 2.2 Å resolution was reported by Scapin *et al.*⁸³ This structure was able to provide direct evidence of the nucleotide binding site (a crystal structure was obtained with NADPH bound to the enzyme). It also explained why NADH is bound more tightly in the active site. Some evidence was presented that a group of positively charged residues (His159, His160, Arg161, His162 and Lys163) formed the substrate binding site. Theoretical studies with DHDP showed that these residues form a good complex with the substrate. It was found that the protein would have to undergo a 30° rotation in order to bring the substrate and cofactor close enough to react.

2.14 Inhibition of DHDPR

The *E. coli* enzyme was found to be inhibited by dipicolinic acid (33). Dipicolinic acid (33) is a linear competitive inhibitor with respect to DHDP (27) with a K_i of 26 μM , and inhibits non-competitively with respect to NAD(P)H with a K_i of 330 μM . The inhibition of the enzyme by dipicolinic acid is taken as evidence that it is the cyclic form, and not any ring opened form, of DHDP (27) that is the substrate of the enzyme. On this basis analogues of dipicolinic acid (33) were tested as inhibitors. *iso*-Phthalic acid (50) showed moderate inhibition with an IC_{50} of 2 mM, but compounds with only one carboxylate group such as pipercolinic acid (51) and picolinic acid (52) were much less effective with IC_{50} values of greater than 20 mM. Pyridinedicarboxylic acids [e.g. (53)] were found not to be inhibitory.



Tyagi *et al.*⁸⁰ found that DHDPR isolated from maize was inhibited by dipicolinic acid (33) with a K_i value of 0.9 mM, indicating that, as with *E. coli* the wheat DHDPR binds the product in its cyclic form. They found that a number of other

compounds with similar structures to DHDP (27) also inhibited the enzyme, see **table 3**.

Inhibitor	% inhibition			
	20 mM	10 mM	5 mM	1 mM
Picolinic acid (52)	24	4	8	0
Pipecolic acid (51)	23	30	0	0
<i>iso</i> -phthalic acid (50)	44	20	0	0
Isocinchomeronic acid (53)	-	-	50	0
Dipicolinic acid (33)	-	-	-	100

Table 3: Inhibitors of wheat DHDPR

2.15 Succinyl CoA: L-tetrahydrodipicolinate *N*-succinyltransferase (THDP succinylase) (*dapD*)

Succinyl CoA: L-tetrahydrodipicolinate *N*-succinyltransferase catalyses the ring opening reaction of L-THDP (28). The succinyl group also acts as a protecting group for the transamination reaction that follows. The enzyme requires succinyl CoA as a second substrate for the reaction. The reaction catalysed is shown in **Figure 30** below.

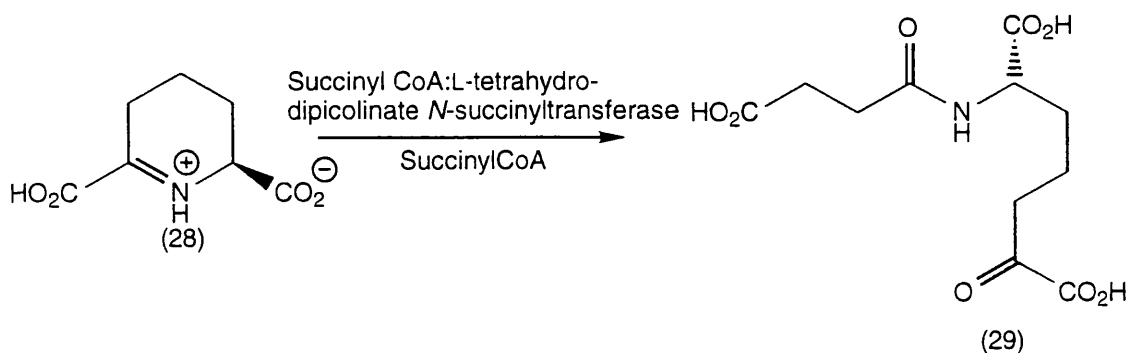


Figure 30: The reaction catalysed by THDP succinylase

2.16: Isolation and characterisation of THDP succinylase

The purification and characterisation of THDP succinylase was not fully investigated until recently. This was due to the unavailability of the enzyme substrate, THDP (28) which has only recently been synthesised, see section 2.17. Simms *et al.*⁸⁴ purified THDP succinylase from *E. coli*. They achieved a purification factor of 1900 fold from crude *E. coli* extracts. The standard assay needs samples of THDP (28) which were prepared enzymically by the oxidative deamination of *meso*-DAP (6) in the presence of NADPH and *meso*-DAP

dehydrogenase. The protein was found to be homogeneous by polyacrylamide gel electrophoresis and consists of two subunits of molecular weight 31,000. The pH optimum for the reaction is 8.0 and the equilibrium lies to the product side. The equilibrium can be perturbed towards L-THDP (28) by careful choice of conditions. The forward reaction proceeds 380 times as fast as the reverse reaction under standard conditions.⁸⁵

It was noted that the enzyme lost 80% of its activity within four days if mercaptoethanol was left out of the buffer in which the enzyme was stored. This was taken as evidence for the presence of an active site sulfhydryl group. No loss of activity was noted if the enzyme was stored in buffer containing 0.01% mercaptoethanol. Furthermore, known inhibitors of sulfhydryl-containing enzymes were found to be effective inhibitors of THDP succinylase.

Richaud *et al.*⁸⁵ were able to determine K_m values for the substrates of the reaction. The K_m for THDP (28) was determined to be 22 μM and for succinyl CoA the K_m was 15 μM .

2.17 Synthesis of L-THDP

The synthesis of L-THDP (28) by chemical means was recently reported by Couper *et al.*⁸⁶ This was not the first reported synthesis for L-THDP (28). Shapshak⁸⁷ claimed to have prepared L-THDP (28) by treating DL-2,6-DAP with L-amino acid oxidase from *Neurospora crassa*, but there was no supporting chemical or spectroscopic evidence provided.

Cyclisation of $\alpha\alpha'$ -dioxopimelic acid (54) with ammonia was attempted by Kimura and Sasakawa,⁸⁸ see **figure 31**. They reported that they had formed both dipicolinic acid (33) and DL-THDP (28) by a disproportionation reaction from the initial product, 1,4-dihydrodipicolinate (55). They presented as evidence the UV absorption spectrum of dipicolinic acid and colour changes on reaction with ninhydrin and *o*-aminobenzaldehyde (for THDP (28)).

A recent report, by Couper *et al.*,⁸⁶ described the preparation of the dipotassium salt of L-2,3,4,5-THDP (59). The compound was prepared by the elimination of *p*-toluenesulfinic acid from the *N*-tosyl derivative (58) of dimethyl *cis*-piperidine-2,6-dicarboxylate (57), see **figure 32**.

Dimethyl dipicolinate (56) was prepared from dipicolinic acid (33) by heating at reflux in methanol and concentrated sulfuric acid. Hydrogenation of the diester

(56), using platinum (IV) oxide gave dimethyl *cis*-piperidine-2,6-dicarboxylate (57). Tosylation of the nitrogen atom using toluenesulfonyl chloride and pyridine gave (58), set up for the elimination.

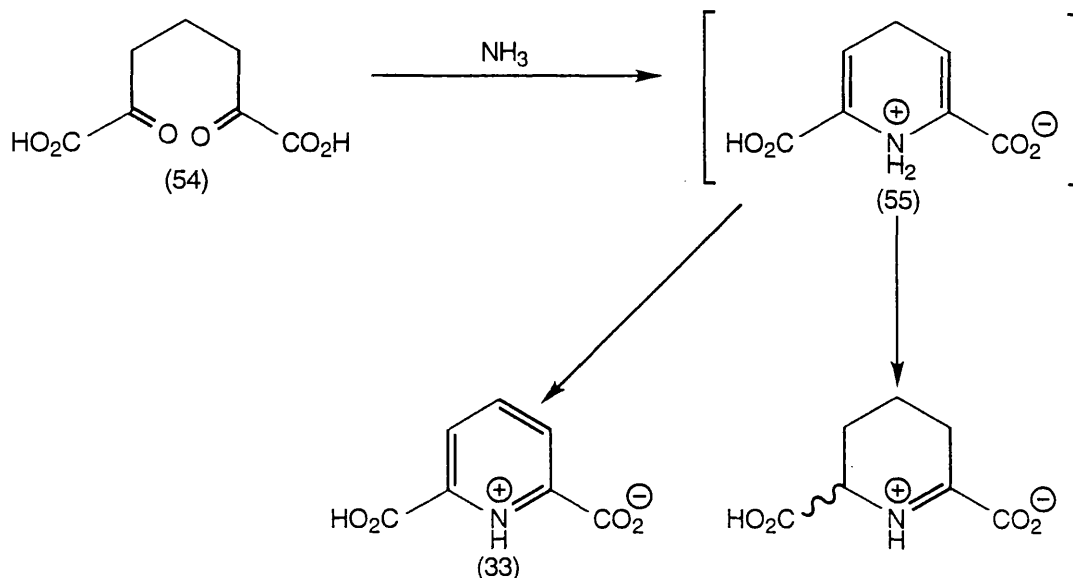


Figure 31: Kimura and Sasakawa synthesis of DL-THDP

The elimination was carried out using potassium *tert*-butoxide in dichloromethane at room temperature. This procedure also cleaved the ester groups. Purification of the dipotassium salt of L-2,3,4,5-tetrahydrodipicolinic acid (59) was achieved by means of Amberlite resin. The ^1H and ^{13}C NMR data quoted suggest that the dipotassium salt of L-2,3,4,5-THDP (59) exists in equilibrium in solution. There were signals visible for both the open chain form (61) and the enamine (60). The dipotassium salt of L-2,3,4,5-THDP (59) was shown to be a substrate of *meso*-DAP dehydrogenase by monitoring the disappearance of NADPH when it was incubated with the enzyme.

2.18 Mechanism of THDP succinylase

A stereochemical model for the mode of action of THDP succinylase was proposed by Berges *et al.*⁸⁹ The model is based on the results of studies using cyclic and acyclic analogues of L-THDP (28) and is shown in **figure 33**.

From the testing of cyclic and acyclic compounds as inhibitors, Berges *et al.* were able to draw some conclusions about the active site of the enzyme. The proposed model involves the initial binding of L-2,3,4,5-THDP (28) to the active site of the enzyme. Water then adds *cis* to the *re*-face of the imine double bond

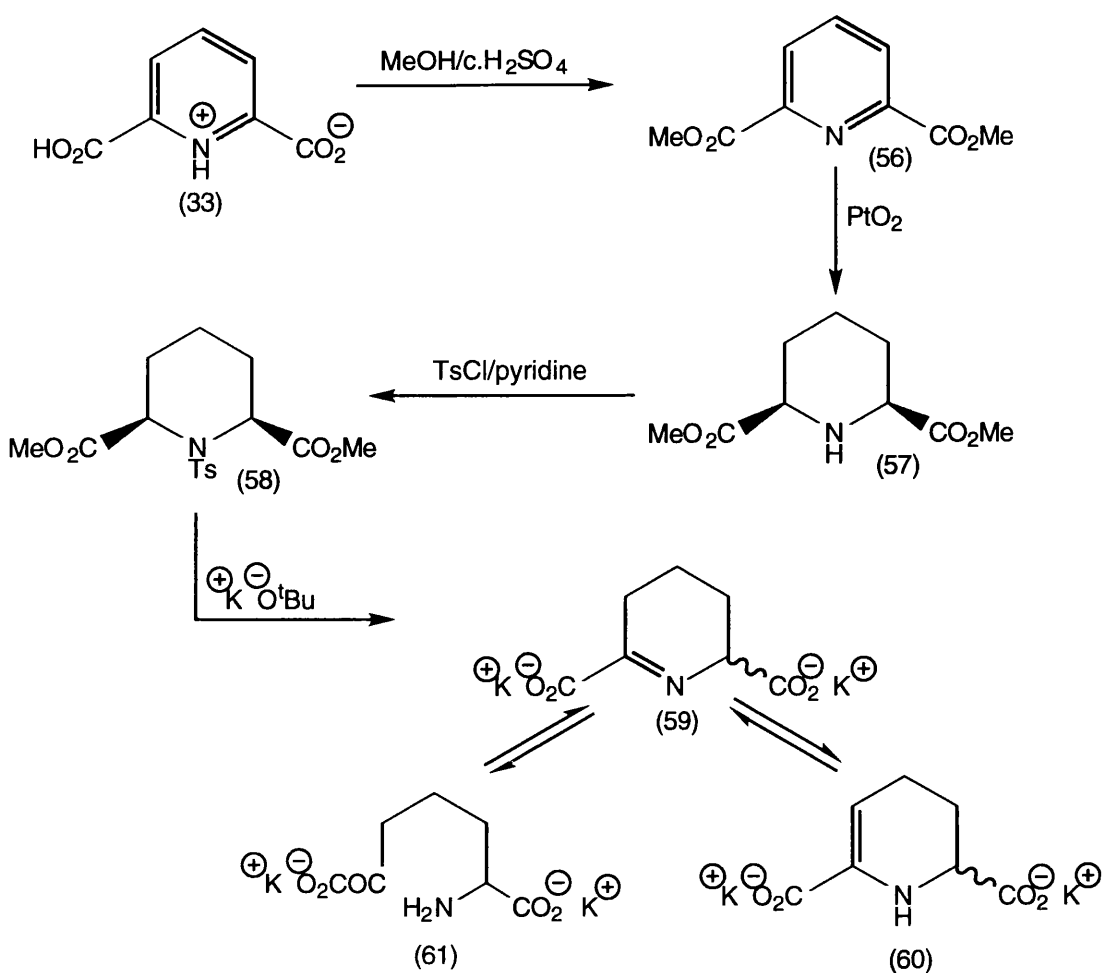


Figure 32: Synthesis of the potassium salt of L-2,3,4,5-THDP

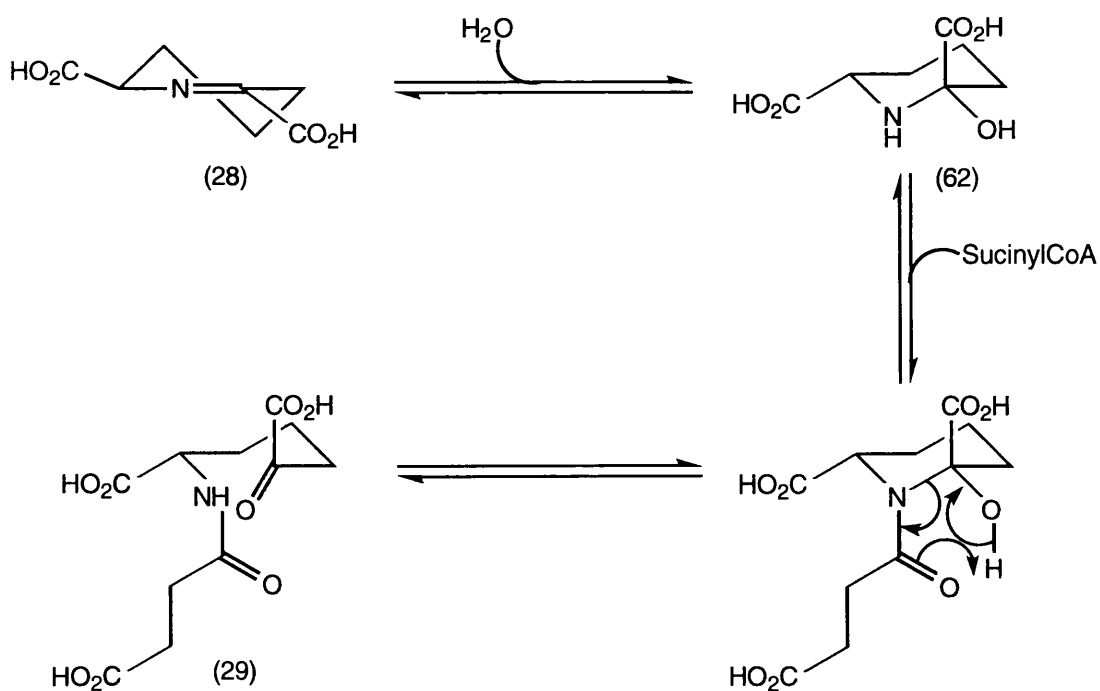
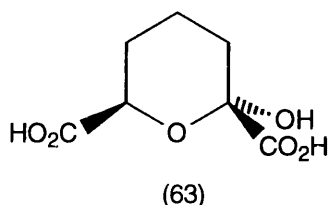


Figure 33: Stereochemical model for the mode of action of THDP succinylase

producing a *trans*-piperidine-2,6-dicarboxylic acid (62). The hydrated product then undergoes a succinylation, and finally ring opens to give *N*-succinyl- ϵ -keto- α -aminopimelic acid (29).

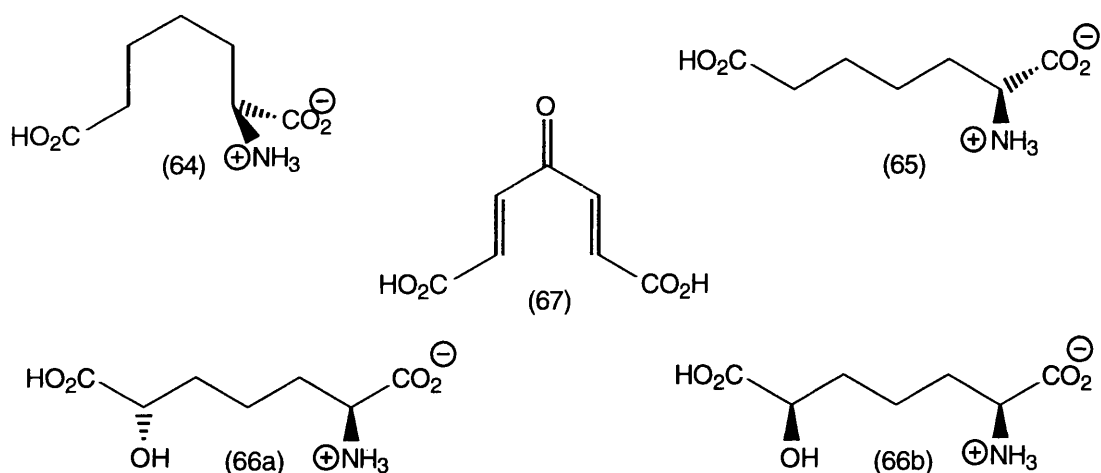
An important piece of evidence which lends credence to this proposed stereochemical model is that 2-hydroxytetrahydropyran-2,6-dicarboxylate (63) was found to be a very potent inhibitor. The proposed model of the mechanism suggests that (63) should be a very close match to the transition state of the enzymic reaction. 2-Hydroxytetrahydropyran-2,6-dicarboxylate (63) bears a very close resemblance to the proposed hydrated intermediate (62). The K_i was found to be 58 nM, supporting the proposed similarity to the transition state.



2.19: Inhibitors of THDP succinylase

The development of inhibitors of THDP succinylase has been split between the search for acyclic compounds that fold up to mimic the active site conformation and cyclic compounds where the geometrical requirements of the active site have been designed into the molecule.

Berges *et al.*⁸⁹ found that D-2-aminopimelate (64) was a reasonable inhibitor of THDP succinylase with a K_i value of 0.76 mM. The presence of the two carboxylate groups was shown to be important for good binding to the enzyme. D- and L-aminoadipic acid and DL-aminosuberic acid were very poor inhibitors of the enzyme. They were thought to be too small and too large respectively to adopt the correct conformation in the active site of the enzyme. Berges *et al.*⁸⁹ also attempted replacement of a methylene group with a sulfur atom. This had little effect as DL-2-amino-5-thiapimelic acid was found to have a K_i value of 1.1 mM.



The presence of an α -hydroxy moiety is preferred slightly over an α -amino for binding. Thus LL- α -amino- ϵ -hydroxypimelate (66a) is succinylated at 43% of the rate of L- α -aminopimelate (65). It was discovered that L- α -amino-D- ϵ -hydroxypimelate (66b) was succinylated faster than (65). A conformationally restricted compound, 2E,5E- γ -ketoheptadienedioic acid (67), was a good inhibitor with a K_i of 0.53 mM.

The search for cyclic inhibitors produced mainly poor inhibitors. The most notable inhibitor found (64) was acyclic. One compound was found to be a substrate of THDP succinylase, namely 3,4-dihydro-2H-1,4-thiazine-3,5-dicarboxylic acid (DHT) (68). This compound exists mainly as an enamine, as shown by a ^1H NMR spectrum of the disodium salt recorded in aqueous solution, see **figure 34**. DHT (68) has a K_m value of 2 mM and this can be explained by the fact that only a very small proportion of the DHT (68) is at any time in the imine form (69).

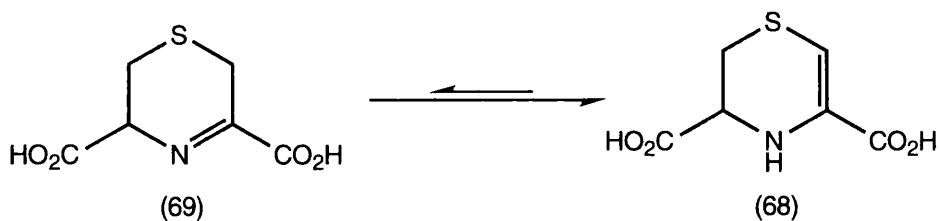


Figure 34: DHT Tautomerisation

Other cyclic compounds prepared as potential inhibitors include those shown in **figure 35**. Most of these exhibited poor K_i values.

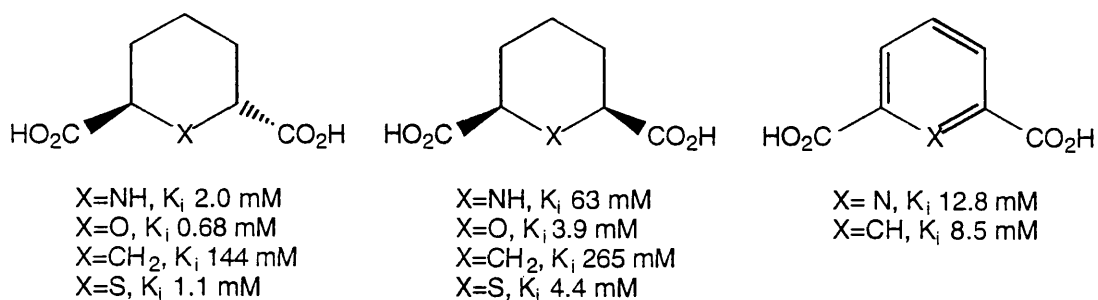


Figure 35: Cyclic inhibitors of THDP succinylase

2.20 *N*-Succinyl-LL-diaminopimelate aminotransferase (EC 2.6.1.17, *dapC*)

N-Succinyl-LL-diaminopimelate aminotransferase catalyses the conversion of *N*-succinyl- α -amino- ϵ -ketopimelate (29) into *N*-succinyl-L-diaminopimelate (30), see **Figure 36**. The succinylated intermediate is aminated at the ϵ -position with glutamate (69) providing the amino group.

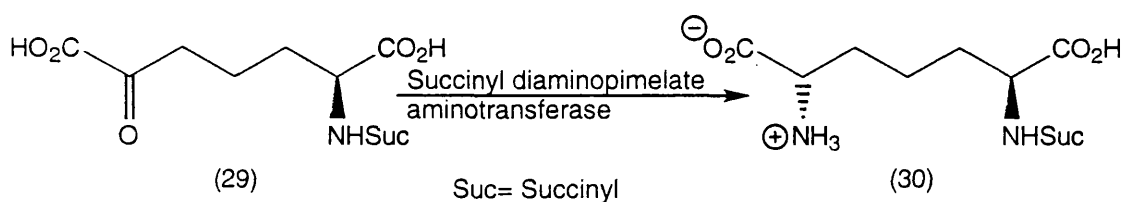


Figure 36: The reaction catalysed by *N*-succinyl-LL-diaminopimelate aminotransferase

2.21: Isolation and characterisation of succinyl-LL-diaminopimelate aminotransferase

The aminotransferase has been purified to homogeneity from *E. coli* and its activity has been detected in both Gram positive and negative bacteria.⁹⁰ The *E. coli* enzyme was found to be a homodimer of subunit molecular weight 39,900.⁹¹ The enzyme is pyridoxal phosphate (PLP) dependent and requires glutamate (69) as its sole source of the transferable amino group. Michaelis constants for the natural substrates have been measured. L-Glutamate (69) was found to have a K_m of 1.2 mM and L-*N*-succinyl- α -amino- ϵ -ketopimelic acid (30) had a K_m of 0.18 mM. The standard assay for measurement of the activity of the aminotransferase involves the spectrophotometric observation of the disappearance of NADPH when a coupled assay with glutamate dehydrogenase is used. Under physiological conditions the reaction is freely reversible.

2.22: Mechanism of *N*-succinyl-LL-diaminopimelate aminotransferase

Kinetic studies suggest that the reaction mechanism is sequential with glutamate (69) binding and reacting before *N*-succinyl- α -amino- ϵ -ketopimelic acid (30) binds and reacts. Glutamate (69) binds and reacts with PLP to form the active transferase enzyme, see **figure 37**. The reaction proceeds through aldimine, quinonoid and ketimine intermediates.

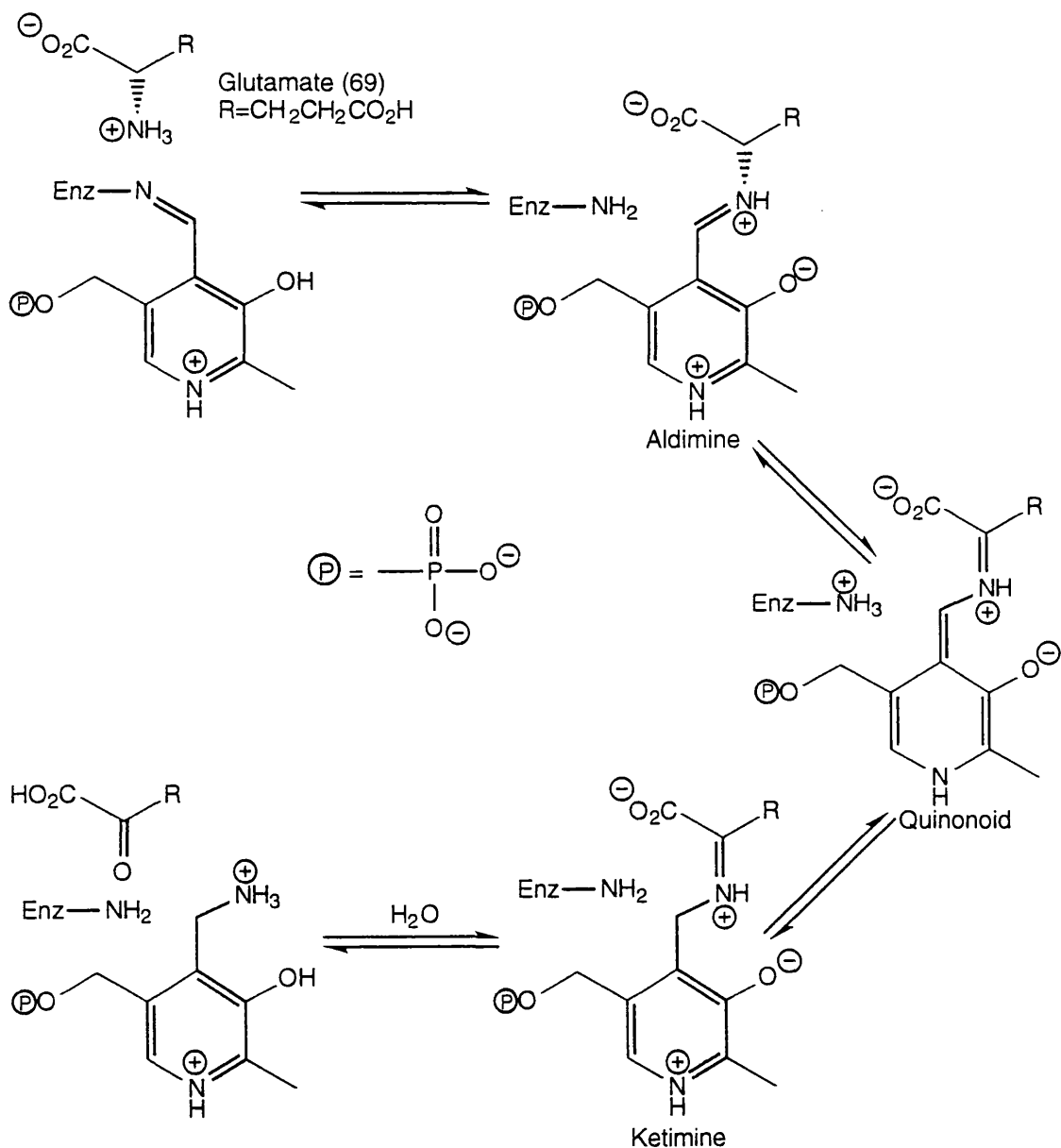


Figure 37: Initial steps in the mechanism of *N*-succinyl diaminopimelate aminotransferase

The placement of the amino group onto *N*-succinyl- α -amino- ϵ -ketopimelic acid (29) occurs next by reversing the steps shown for the transfer of the amino group to the cofactor, see **figure 38**. The enzyme behaves as expected for an

aminotransferase and obeys the characteristics of the model system, aspartate aminotransferase.⁹²



Figure 38: Transfer of the amino group to *N*-succinyl- α -amino- ϵ -ketopimelic acid

2.23: Inhibition of *N*-succinyl-LL-diaminopimelate aminotransferase

As is common with aminotransferases, *N*-succinyl-LL-diaminopimelate aminotransferase is inhibited by hydrazine, hydroxylamine and their substituted derivatives. These compounds react with pyridoxal phosphate at the active site to produce stable nitrones⁹³ and hydrazones⁹⁴ which cannot take any further part in the reaction catalysed, see **figure 39**. These compounds have proven resistant to hydrolysis. This was seen as a good way to develop novel inhibitors. By utilising the hydrazine/hydroxylamine moiety to inactivate the enzyme and constructing a framework round it that was strongly recognised by the enzyme, potent inhibitors could be developed. It was discovered that the two acid groups were required by the enzyme as was the LL-configuration at the two chiral centres. Using this information two compounds were developed utilising the LL-DAP skeleton with a succinyl group (70) and with a CBZ group (71). These compounds were found to be potent, slow binding inhibitors of the enzyme with K_i values of 22 nM and 54 nM, respectively.⁹¹

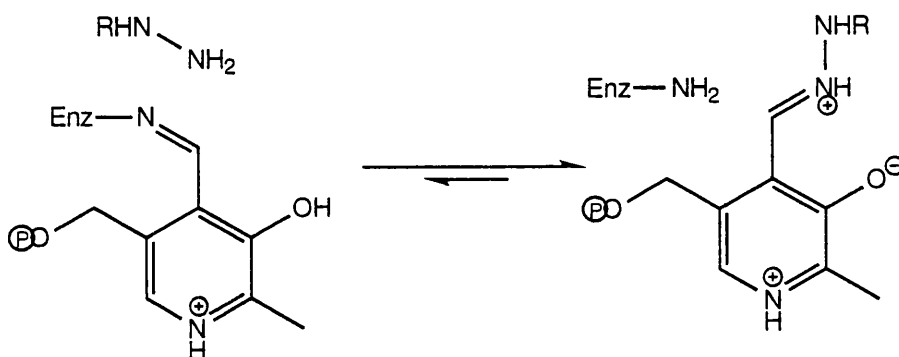
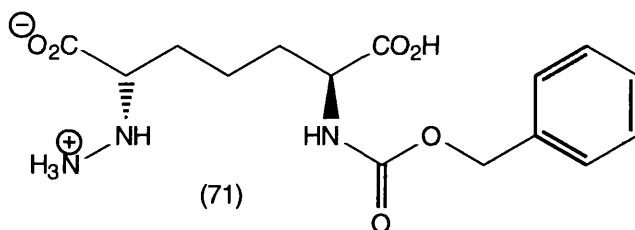
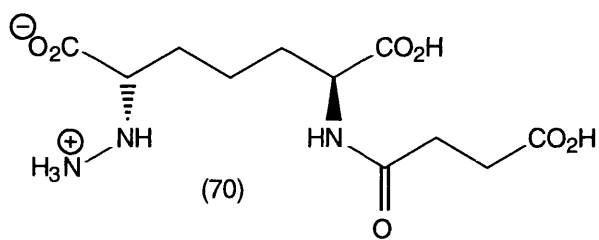


Figure 39: Inhibition of *N*-succinyl-LL-diaminopimelate aminotransferase by hydrazine derivatives



2.24: *N*-Succinyl-L-lysine desuccinylase (EC 3.5.1.18, *dapE*)

N-Succinyl-L-lysine desuccinylase catalyses the deacylation of *N*-succinyl-L-lysine (30) to L-lysine (31) as shown in **figure 40**.

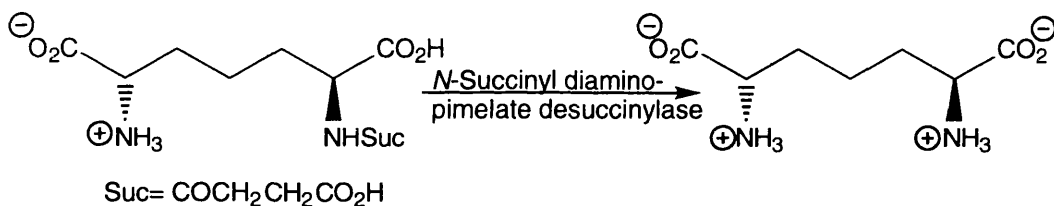


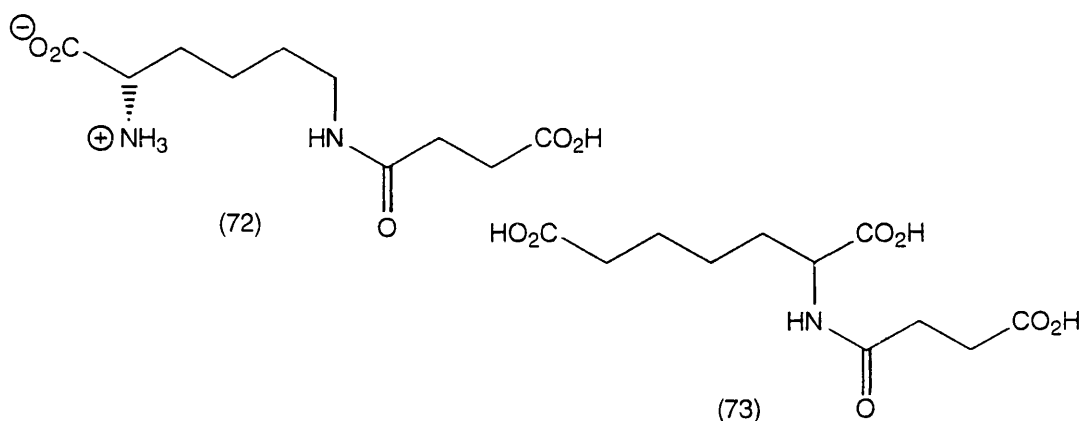
Figure 40: The reaction catalysed by *N*-succinyl-L-lysine desuccinylase

2.25: Isolation and characterisation of *N*-succinyl-L-lysine desuccinylase

The *E. coli* enzyme has been isolated and purified to homogeneity⁹⁵ and DAP desuccinylase activity has been detected in a number of bacterial species.⁹⁶ The *E. coli* enzyme has been shown to be dimeric at low concentrations (< 1 mg/ml) and tetrameric at higher concentrations. The subunit molecular weight was determined to be 40,000 which is in agreement with the figure of 41,129 derived from the nucleotide sequence of the *dapE* gene.⁹⁷ The *DapE* locus of *C. glutamicum* has also been sequenced and predicts a subunit molecular weight of 39,942.⁹⁸

The *E. coli* enzyme was shown to require a metal ion, ideally cobalt (II), but zinc (II), iron (III) and nickel (II) have been shown to be acceptable. The reaction proceeds at a lower rate (~2.2 fold turnover decrease) with these metals. The enzyme is functionally very similar to the many cellular carboxypeptidases, and shares 38% sequence homology with acetylornithine deacetylase from *E. coli*.⁹⁹

The Michaelis constant for the natural substrate was determined to be 410 μM and a systematic study was undertaken to find substrate analogues. The *E. coli* desuccinylase will hydrolyse LL- and *meso*-*N*-succinyl DAP compounds (the succinyl group must be attached to the L-centre). L- α -*N*-Succinyllysine (72) was found to be a very poor substrate (0.016% of the rate for the natural substrate) as was LL-*N*-acetyl DAP. A mixture of isomers of *N*-succinyl- α -aminopimelate (73) proved also to be a poor substrate (0.036% of the rate for the natural substrate).



2.26: *meso*-Diaminopimelate epimerase (EC 5.1.1.7, *dapF*)

meso-Diaminopimelate epimerase (*meso*-DAP epimerase) is responsible for the epimerisation of the ϵ -amino group of LL-DAP (31) to produce DL- or *meso*-DAP (6), see **figure 41**.

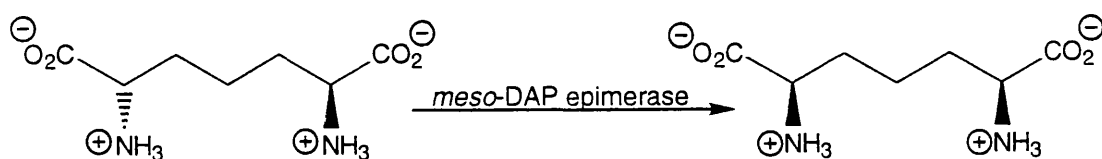


Figure 41: The reaction catalysed by *meso*-DAP epimerase

2.27: Isolation and characterisation of *meso*-DAP epimerase

meso-DAP epimerase was first isolated over 30 years ago from *E. coli*¹⁰⁰ but was only recently purified and characterised by Wiesman and Nichols.¹⁰¹

Purification was difficult due to the presence of a free thiol residue which was necessary for activity. The *Bacillus megaterium* enzyme has also been isolated but only purified 20 fold.¹⁰² The *E. coli* enzyme has received most attention and the *dapF* locus has been cloned,¹⁰³ sequenced¹⁰⁴ and overexpressed.¹⁰⁵ The epimerase was found to be monomeric, with a molecular weight of 34,000 from gel filtration experiments. The molecular weight was refined to 30,265 from the nucleotide sequence.

As mention above the enzyme interconverts LL-DAP (30) and *meso*-DAP (6). The DD-DAP compound is not a substrate for the enzyme. It is therefore the stereochemistry of the non-reacting centre that governs substrate recognition by the enzyme. The stereochemistry of the other ϵ -centre is fully reversible under physiological conditions. The Michaelis constants for the substrates have been determined. For LL-DAP (30) the K_m value of 160 μ M was found and for *meso*-DAP (6) the K_m value found to be 360 μ M. An equilibrium constant of 2.0 was derived from HPLC analysis.

There are two assay systems for the enzyme. The first monitors the release of tritium from α -tritiated DAP. The second is easier and involves a coupled assay system with *meso*-DAP dehydrogenase. The assay system relies on the turnover of NADP⁺ to NADPH by *meso*-DAP dehydrogenase and can be monitored spectrophotometrically at 340 nm.

2.28: Mechanism of *meso*-DAP epimerase

It was discovered early on that the enzyme did not require PLP as a cofactor and that it was not inactivated by hydrazine. No evidence for a reducible imine could be found and sodium borohydride did not inactivate the enzyme. Metal ions, flavin and nicotinamide cofactors were not utilised by the enzyme. It was discovered that for substrates labelled with an α -tritium, exchange with the solvent was rapid and reversible. The enzyme was also found to be unstable in solution without the presence of dithiothreitol, or similar reducing agent. A time dependent inactivation by iodoacetamide was discovered and one molecule of acetamide was bound per enzyme molecule. This evidence was enough to enable the proposal of a base catalysed abstraction of the α -proton as a likely mechanism for *meso*-DAP epimerase.

The abstraction of tritium has been thoroughly investigated.¹⁰¹ This involved detailed kinetic studies to determine the rates of tritium abstraction from *meso*-DAP and LL-DAP. It was found that the rates of abstraction for the two

substrates were different and that in each turnover of the enzyme a tritium was exchanged for a solvent derived proton. This was taken as evidence for a mechanism involving two bases. A single base mechanism involving abstraction from one face and reprotonation from the other is not supported by the evidence presented, see **figure 42**.

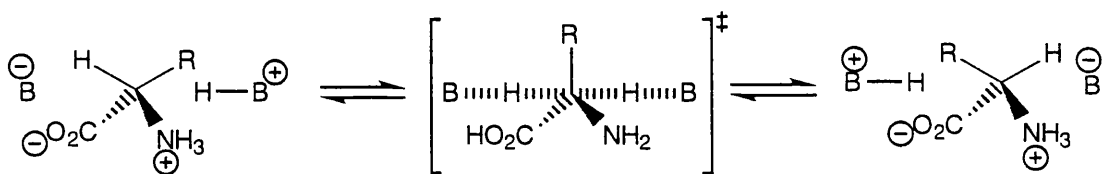


Figure 42: Two base mechanism for *meso*-DAP epimerase

It has been suggested that *meso*-DAP epimerase bears a resemblance to proline racemase in its mechanistic behaviour.¹⁰⁶ *meso*-DAP epimerase differs from proline racemase because the kinetic evidence does not support the two bases being the same (the kinetic isotope effects are different). It is however known that one of the bases is in fact a thiol as shown by the removal of catalytic activity of *meso*-DAP epimerase when treated with azi-DAP (74), which covalently binds to Cys73 of *meso*-DAP epimerase,¹⁰⁷ see **figure 43**.

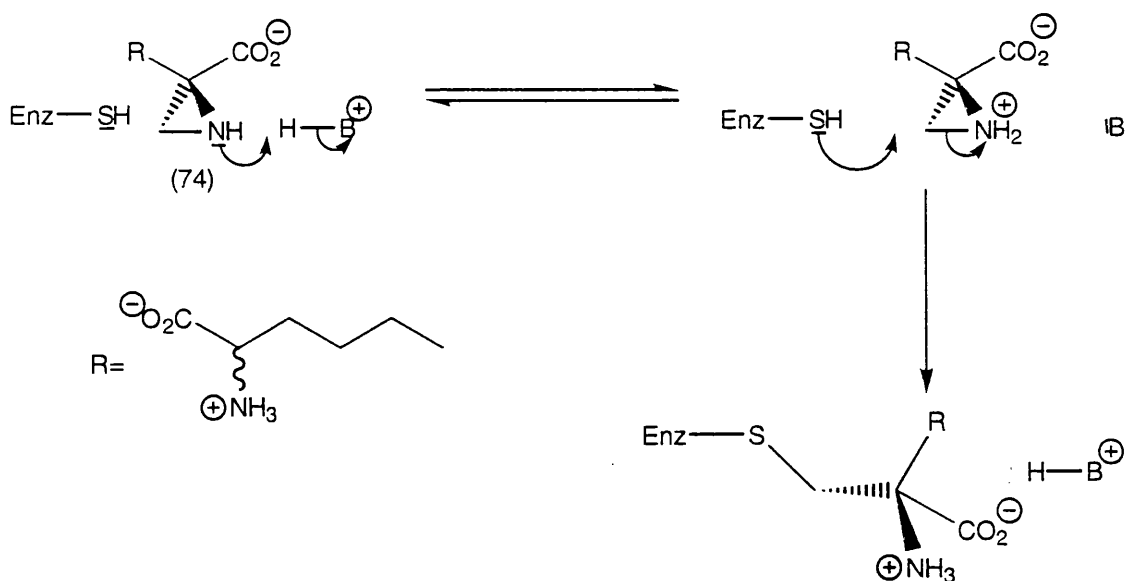


Figure 43: Inactivation of *meso*-DAP epimerase by azi-DAP

Studies of other epimerases have been of great interest to try to understand how a base of pK_a of about 15 can deprotonate the α -carbon of an amino acid, which has a pK_a of >20 . This apparent paradox has recently been solved with the experimental validation of the concept of short-strong hydrogen bonds.^{108,}
¹⁰⁹ These are believed to occur between the active site residue and the carboxylate in the transition state. These H-bonds have been described as “low

barrier" and can help stabilise transition states to a large degree. This then affects the pK_a of the α -hydrogen, making the proton abstraction possible. This is the currently accepted explanation for the paradox, but it has yet to be proved in the case of *meso*-DAP epimerase.

2.29: Inhibition of *meso*-DAP epimerase

The proposed mechanism for the reaction catalysed by *meso*-DAP epimerase requires that a negative charge be located on the α -carbon atom. This feature has been exploited in an attempt to develop inhibitors of *meso*-DAP epimerase. There are two main areas that have been explored. The first is compounds that are unstable after proton abstraction, such as compounds set up for β -elimination, and secondly compounds with good leaving groups on the nitrogen atom. A good example of this was the development of β -chloro DAP (75) by Baumann *et al.*¹¹⁰ This compound was a potent inhibitor of the epimerase with a K_i of 200 nM. Inhibition was found to be reversible and competitive with the substrate. At low concentrations the inhibition decreased with time, indicating that the inhibitor was acting as a poor substrate towards the enzyme. Baumann *et al.*¹¹⁰ carried out experiments to determine the product of the reaction and found that the product reacted with *meso*-DAP dehydrogenase. This meant that the enzyme was catalysing the elimination of HCl from β -chloro-DAP (75) to give an enamine intermediate (76) which transformed slowly into L-THDP (27), see figure 44.

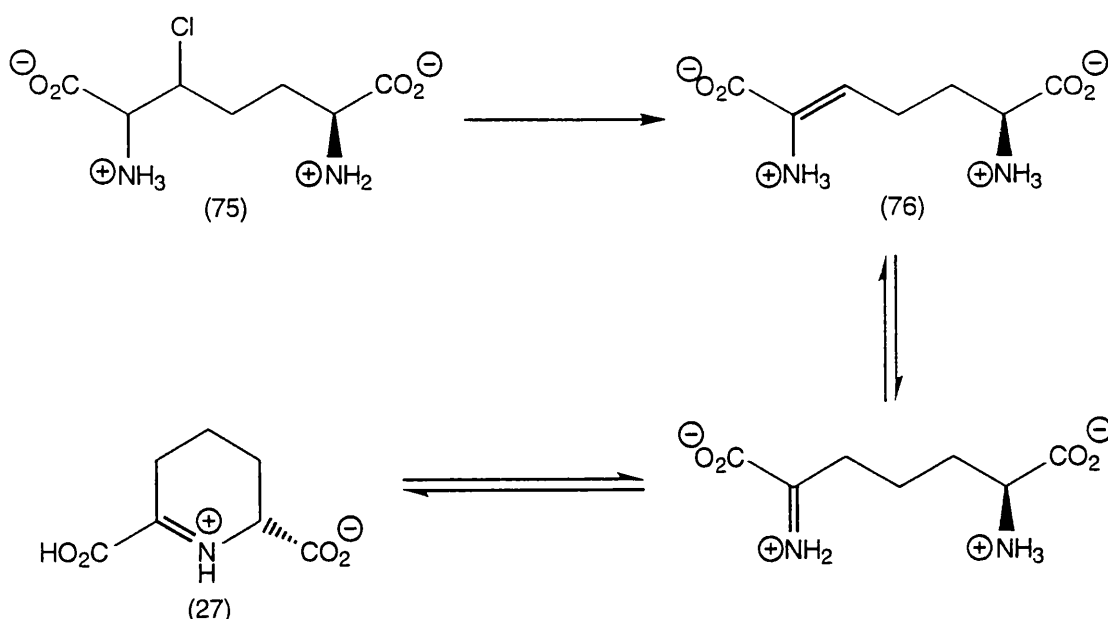


Figure 44: Turnover of β -chloro-DAP by *meso*-DAP epimerase

Further to the determination that β -chloro-DAP was turned over by the enzyme, Gelb *et al.*¹¹¹ synthesised the four stereoisomers of β -fluoro-DAP (77a-d). These were found to be good inhibitors of the enzyme with IC_{50} values of 10 mM, 25 mM, 4 mM and 8 mM for compounds, 77a-d respectively. The enzyme was able to eliminate HF from the β -fluoro-compounds again forming L-THDP (27) as the eventual product. The elimination reactions varied in their rates of HF elimination. The rates of epimerisation and elimination were determined separately. For one pair of isomers (77c, d) the elimination was slow but the epimerisation was fast and the two diastereoisomers are in rapid equilibrium. For (77a, b) the elimination was fast and was the only observable reaction. These results enabled Gelb *et al.*¹¹¹ to suggest a stereochemical course of reaction as shown in **figure 45**. The position of the charged groups and the R groups are fixed in the enzyme active site. As expected, when the H and F are *syn*-planar or *anti*-coplanar the elimination is fast. But when the H and F cannot adopt either of these positions the epimerisation was found to be the faster process.

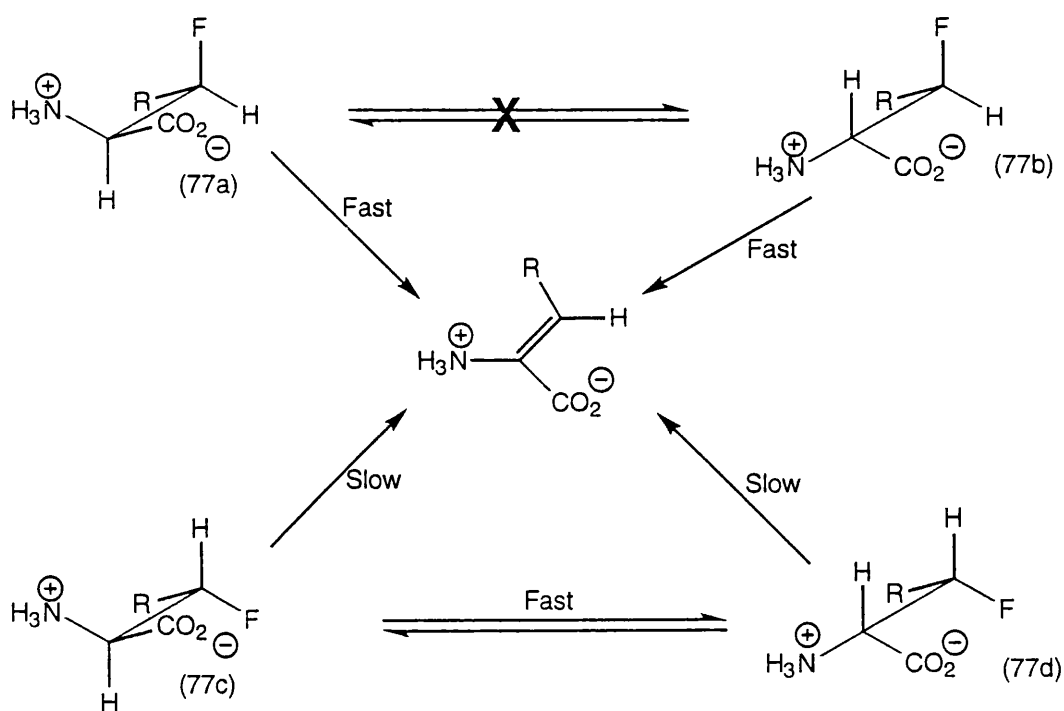
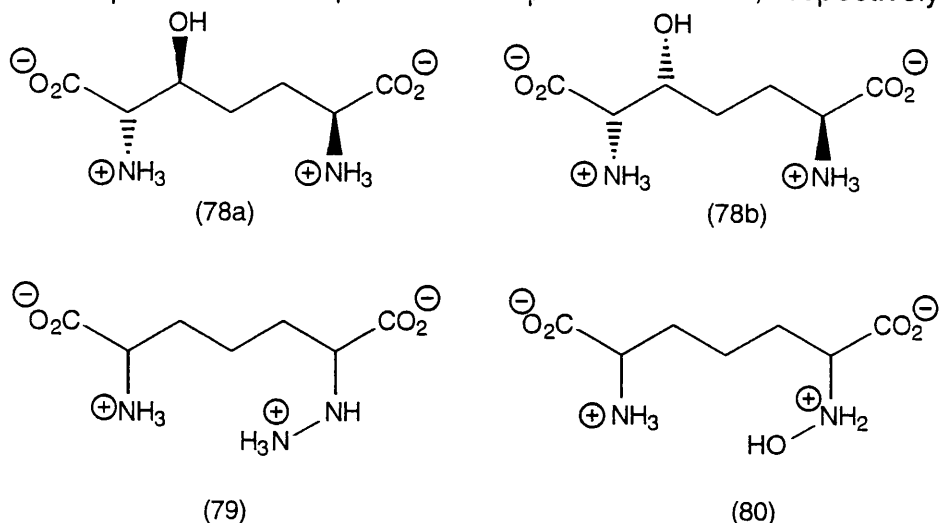


Figure 45: Stereochemical reaction course of β -fluoro-DAP with *meso*-DAP epimerase

Many groups have reported the synthesis of both isomers of β -hydroxy-DAP (78a and b).¹¹⁰⁻¹¹² Both isomers proved to be poor inhibitors, with IC_{50} values of 2.5 and 4 mM, respectively. Water was not eliminated and (78b) was not epimerised while (78a) was epimerised at the carbon distal from the hydroxy

group. *N*-Amino-DAP (79) and *N*-hydroxy-DAP (80) were prepared and inhibited the epimerase with K_i values of 56 μ M and 2.9 mM, respectively.



A great deal of effort has gone into the development of heterocyclic based inhibitors of *meso*-DAP epimerase.¹¹³ These compounds have a planar heterocyclic region (81)-(85) set up to mimic the transition state of the enzyme. None of the compounds proved to be a good inhibitor of *meso*-DAP epimerase.

A number of miscellaneous compounds have been tested for inhibition against *meso*-DAP epimerase. These include the γ -methylene compound (86) and *meso*-lanthionine (87).¹¹⁴ Both were inhibitors, but with K_i values of 0.95 mM and 0.18 mM, respectively, they can be considered moderate at best.¹¹⁵

2.30: *meso*-Diaminopimelate dehydrogenase (EC 1.4.1.16, *ddh*)

The dehydrogenase enzyme catalyses the main step in an alternative pathway to L-lysine in some bacteria and plants. The enzyme cuts out the need for succinylation, transamination, desuccinylation and epimerisation by converting L-THDP (27) directly into *meso*-DAP (6) by utilising NADPH and ammonia, see figure 46.

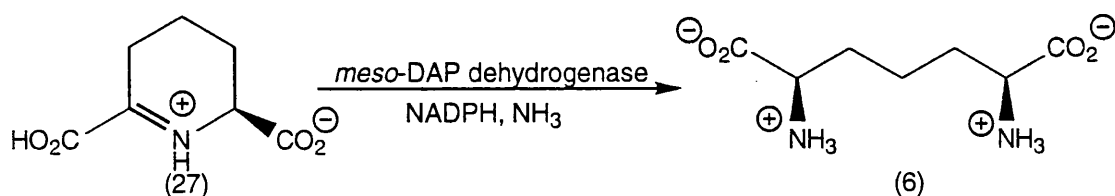
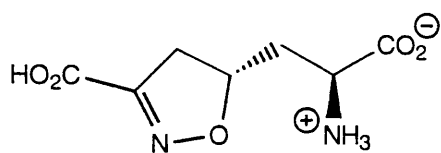
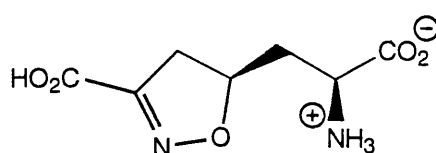


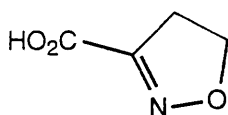
Figure 46: The reaction catalysed by *meso*-DAP dehydrogenase



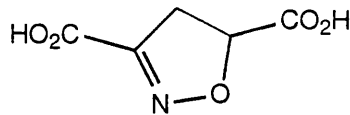
(81)



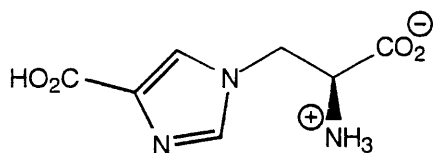
(82)



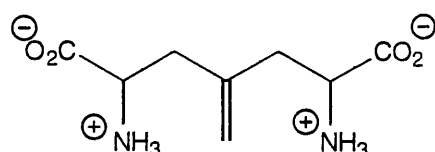
(83)



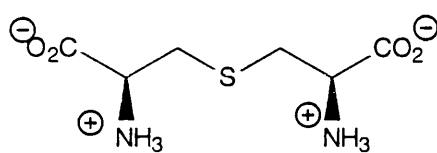
(84)



(85)



(86)



(87)

2.31: Isolation and characterisation of *meso*-DAP dehydrogenase

meso-DAP dehydrogenase occurs in *Bacillus sphaericus*,¹¹⁶ which lacks the enzymes of the other pathway¹¹⁷ and also in many Gram positive and negative bacteria.^{118, 119} Reports have stated that *meso*-DAP dehydrogenase has been found in several plant species, and indeed it has been isolated from the shoots of *Glycine max* by Wenko *et al.*¹²⁰

meso-DAP dehydrogenase has been purified to homogeneity from *Corynebacterium glutamicum*¹¹⁹ and *Brevibacterium spp.*¹²¹ but most of the work on the dehydrogenase has relied on the enzyme isolated from *B. sphaericus*,¹²² which has been reported as having high dehydrogenase activity.¹¹⁸

The dehydrogenase reaction is freely reversible and maximal velocity in the forward direction (to *meso*-DAP) is achieved between pH 7.0 and 8.5. The reverse reaction achieves maximal velocity at pH values between 9.0 and 10.5.¹²³ The reverse reaction can be forced to proceed at pH 7.8 by using NADP⁺ and not supplying ammonia.¹²⁴ An assay system for the enzyme is based on the consumption or generation of NADPH and can be monitored spectrophotometrically at 340 nm.

The bacterial enzymes exist as homodimers with a subunit molecular weight of about 39,000, and there are two active sites per dimer. The *ddh* gene has been cloned from *C. glutamicum* and sequenced.¹²⁵ The inferred subunit molecular weight was 35,099.¹²⁶ The Michaelis parameters for the natural substrates and cofactors of the *B. sphaericus* enzyme have been determined and are shown in **table 4**.

Substrate	K _m (mM)
L-THDP (27)	0.2
NADPH	0.2
NH ₃	12
<i>meso</i> -DAP (6)	2.5
NADP ⁺	0.00083

Table 4: K_m values for the natural substrates and cofactors of *meso*-DAP dehydrogenase from *B. sphaericus*

2.32: The mechanism of *meso*-DAP dehydrogenase

Detailed kinetic analysis of the dehydrogenase has revealed that the mechanism is very ordered.¹²³ In the forward direction NADPH binds followed by L-THDP (27) and then finally ammonia. After the reaction *meso*-DAP (6) is released first followed by NADP⁺. The sequence is reversed for the reverse reaction. This ordered mechanism is reminiscent of the mechanism of glutamate dehydrogenase.

The oxidation reaction takes place at the D-centre and substrate studies have shown that the other centre must have the L-configuration (DD- or LL-compounds were not substrates for the enzyme). The mechanism is believed to involve an acyclic imine (88) resulting from attack of ammonia on L-THDP (27), see **figure 47**. The imine (88) is then hydrogenated by attack of the 4-*pro*-S hydride from NADPH in what is believed to be the rate determining step.

2.33: Inhibition of *meso*-DAP dehydrogenase

Several analogues were tested as inhibitors by Lam *et al.*¹¹⁵ They found that the enzyme was specific for the *meso*-geometry of its natural substrates. They found that *meso*-lanthionine (87) was a weak competitive inhibitor with a K_i of 0.28 mM. Most other analogues were found to be substrates including *N*-

hydroxy-DAP (80) and *N*-amino-DAP (79), which were turned over at 22% and 4% of the rate of the natural substrate, respectively.

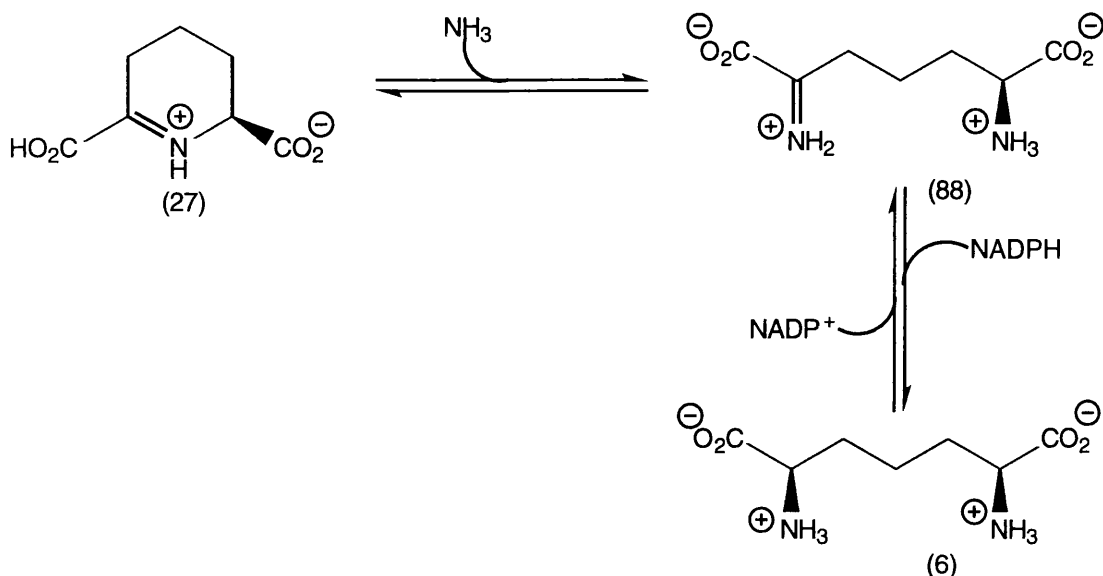
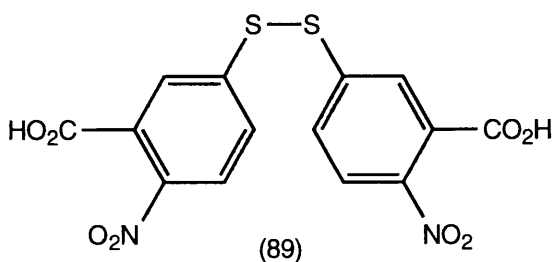


Figure 47: Mechanism of *meso*-DAP dehydrogenase

Abbot *et al.*,¹¹³ as discussed earlier, synthesised a number of isoxazoles (81)-(84) and an imidazole (85) as analogues of *meso*-DAP (6). Of these compounds, (81) was found to be a very potent inhibitor with a K_i of 4.2 μ M. Changing the stereochemistry of the side chain gave (82) which was a poor inhibitor with only 13% inhibition at 1 mM. Removing the side chain entirely or just the amino group gave rise to poorer inhibitors. Isoxazole (81) was discovered to be competing with L-THDP (27) for its binding site within the enzyme.

Other inhibitors of the *B. sphaericus* enzyme have included compounds that attack free thiol groups in enzymes. Bulky sulfhydryl reagents such as Hg²⁺ or 5,5'-dithiobis(2-nitrobenzoic acid) (89) were found to inhibit the enzyme. Activity was restored by adding cyanide and forming an enzyme cyanide adduct. This was taken as an indication that the sulfhydryl group was not necessary for enzyme activity.¹²⁷



2.34: *meso*-Diaminopimelate decarboxylase (EC 4.1.1.20, *lysA*)

The final enzyme in the seven stage pathway to L-lysine (1) via the DAP pathway transforms *meso*-DAP (6) into L-lysine (1) by means of a decarboxylation, see figure 48.

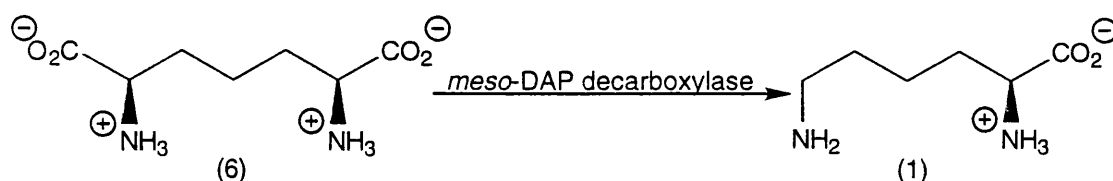


Figure 48: The reaction catalysed by *meso*-DAP decarboxylase

2.35: Isolation and characterisation of *meso*-DAP decarboxylase

meso-DAP decarboxylase is widespread in both plants and bacteria. It has been purified from a number of sources including *E. coli*,^{128,129} *B. sphaericus*,¹³⁰ duckweed (*Lemna perpusilla*)¹³¹ and wheat (*Triticum vulgare*).¹³² The decarboxylase was first detected by Dewey and Work¹³³ in *E. coli* and then was isolated from *B. sphaericus* by Asada *et al.*¹³⁰ They purified the enzyme to homogeneity and were able to determine that the enzyme was a homodimer with a subunit molecular weight of 40,000. The *E. coli* enzyme is a homotetramer, with a subunit molecular weight of 46,099 determined by genetic analysis.¹³⁴ The decarboxylase from *B. sphaericus* was found to have a pH optimum for activity between 6.8-7.8.

Assays for the reaction rely on release of $^{14}\text{CO}_2$ from labelled *meso*-DAP (6) or the determination of L-lysine (1) content in non-continuous assays.¹³⁵ The decarboxylase is specific for *meso*-DAP (6) with a K_m of 1.7 mM for bacterial enzymes and 0.16-0.35 mM for plant decarboxylases. Neither LL- nor DD-DAP are substrates or inhibitors of the enzyme. Thus again it is the non-reacting centre that must possess the L-configuration.

The *lysA* loci has been cloned and sequenced from a number of bacterial species including *B. subtilis*,^{136,137} *B. methanolicus*,¹³⁸ *Mycobacterium tuberculosis*,¹³⁹ *C. glutamicum*¹⁴⁰ and *Pseudomonas aeruginosa*.¹⁴¹ These genes encode for proteins of similar molecular weight (45,000-49,000) and have high sequence homologies.

2.36: The mechanism of *meso*-DAP decarboxylase

The enzyme is PLP dependent and was found to be inhibited by hydrazine and hydroxylamine derivatives. The protein sequence confirms the unique nature of the protein as it is quite different from the structure of other decarboxylases. The *meso*-DAP decarboxylases from various organisms are closely related.¹⁴¹⁻¹⁴⁴ The course of the reaction in *B. sphaericus* has been studied in detail.¹⁴⁵ The reaction as catalysed, proceeds with inversion of stereochemistry; that is the hydrogen is added to the opposite face from which the carbon dioxide was eliminated. This is again quite different from known PLP dependent decarboxylases which catalyse the reaction with retention of stereochemistry.

Two proposals have been put forward to explain this unique feature. The first involves a “swinging door” hypothesis which was made by Asada *et al.*¹³⁰ This suggests that after the decarboxylation has taken place a conformational change occurs in the enzyme allowing a proton source to add to the opposite side of the newly formed double bond. It is stated that this change would have to be quite major in order to place the groups close enough to react. The second hypothesis also presented by Asada *et al.*¹³⁰ involves the protonation of a quinonoid intermediate from the opposite face, see **figure 49**.

As is common with other PLP reactions the plane of the bond which is to be broken must be aligned perpendicularly to the plane of the π -system of the aromatic ring. In this case it is the carboxyl group that should adopt this position to enable the orbitals to line up for the movement of electrons to take place, see **figure 50**.

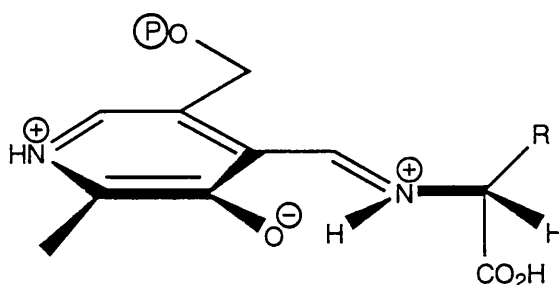


Figure 50: stereochemical alignment for *meso*-DAP dehydrogenase

2.37: Inhibition of *meso*-DAP decarboxylase

Many of the inhibitors of *meso*-DAP decarboxylase have been based on analogues of the starting material. Kelland *et al.*¹⁴⁶ prepared many analogues of *meso*-DAP (6). The best of these analogues were lanthionine sulfoxides (90)

which were found to give 50% inhibition at a concentration of 1 mM. The corresponding sulfones gave poorer inhibition values. Better inhibition figures were obtained for *N*-hydroxydiaminopimelate (80) and *N*-aminodiaminopimelate (79) (mixture of isomers) which gave K_i figures of 0.91 and 0.71 mM and 0.1 and 0.084 mM, respectively.

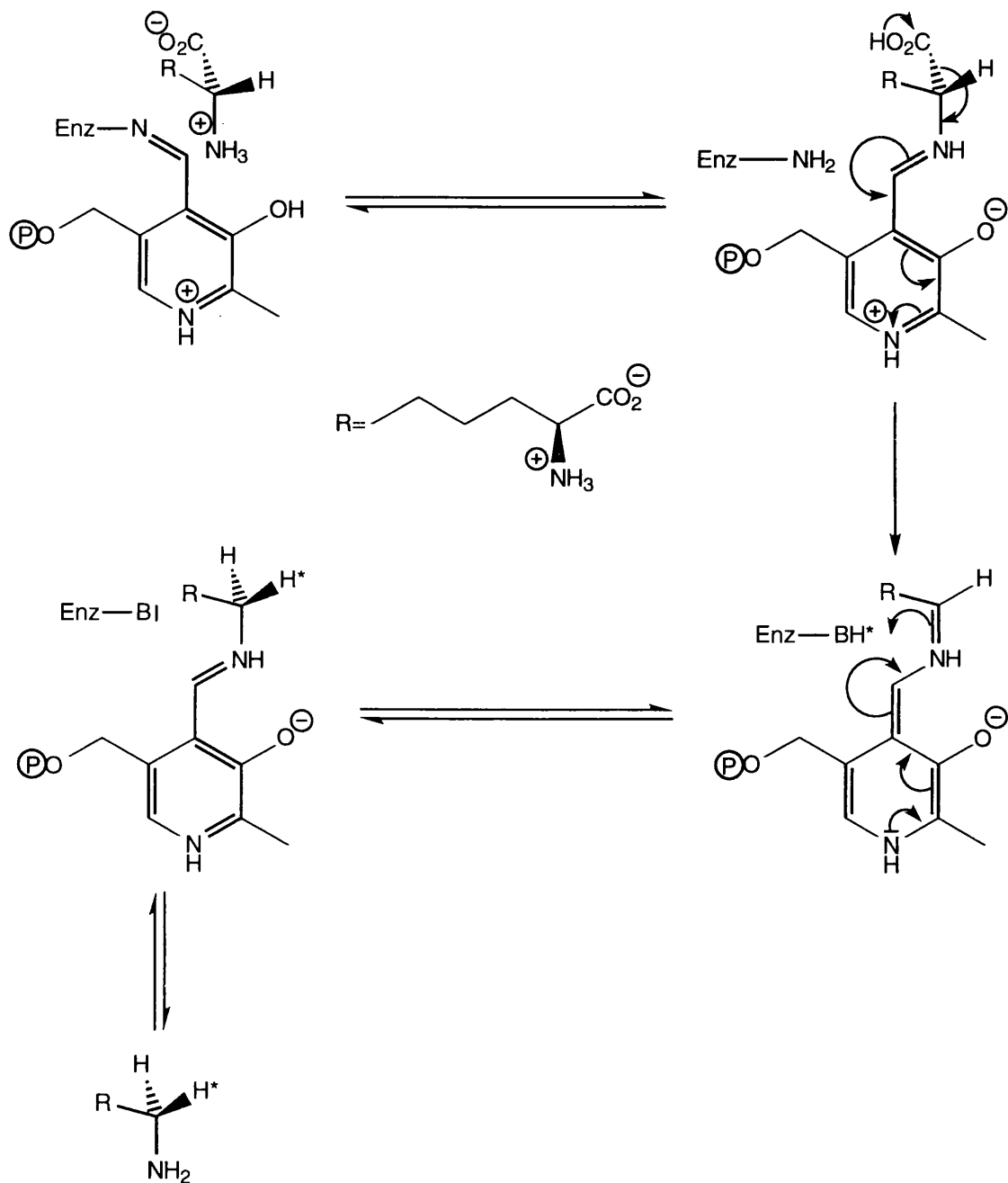


Figure 49: Mechanistic proposal for *meso*-DAP decarboxylase

Girodeau *et al.*¹⁴⁷ synthesised unsaturated analogues of *meso*-DAP (6) and tested them against the dehydrogenase from *E. coli*. The best of the compounds was *trans*-3,4-didehydro-DAP (91) which was the most potent inhibitor of *meso*-DAP decarboxylase with a K_i of 180 μ M.

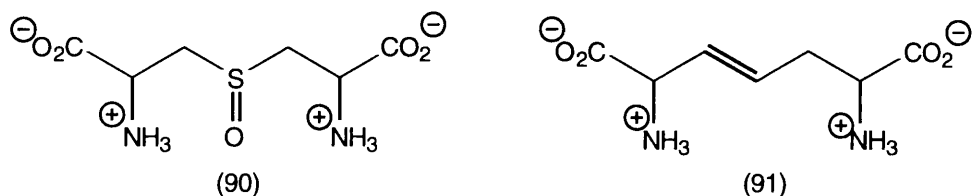


Figure 51 shows the mode of action envisioned by Girodeau *et al.* for these compounds. A active site base was expected to attack the PLP intermediate and to attach the compound covalently to the active site.

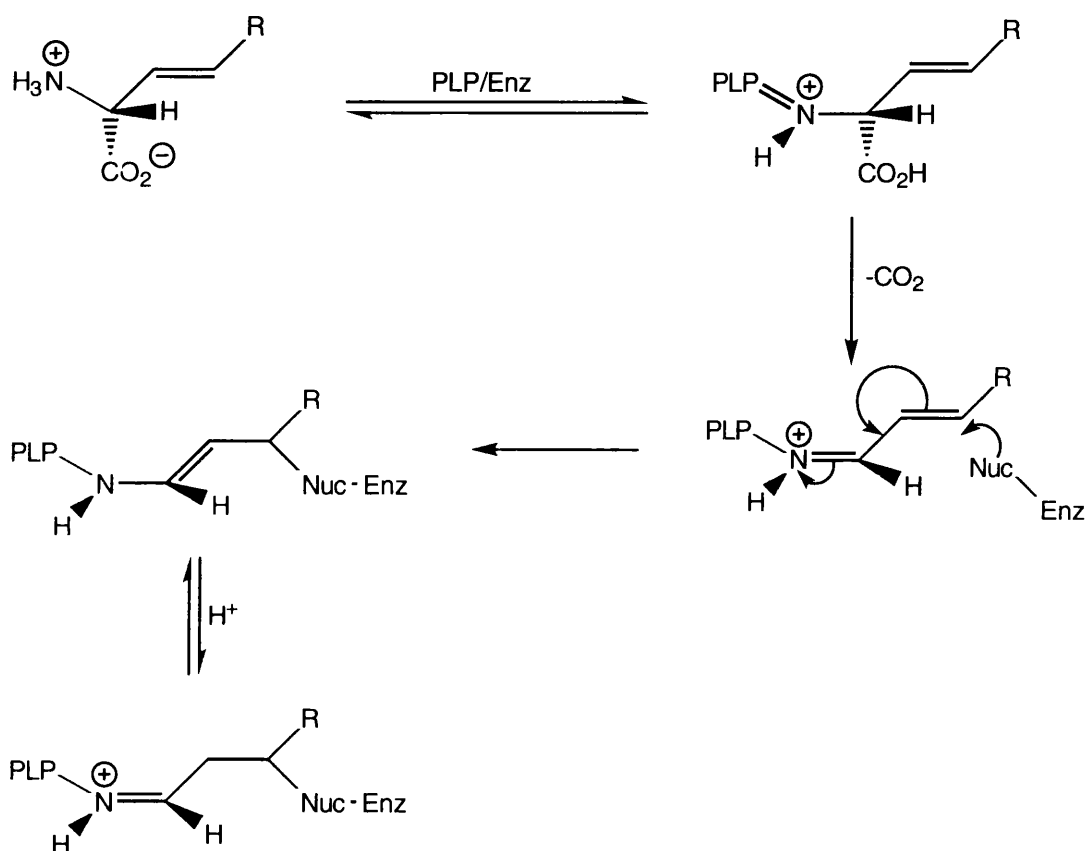


Figure 51: Mode of action of unsaturated analogues of *meso*-DAP

α -Difluoromethyl-compounds are known to inhibit other PLP dependent dehydrogenases. These compounds can undergo a series of eliminations at the active site resulting in irreversible enzyme inactivation.¹⁴⁸ When α -difluoromethyl-DAP (92) was made and tested against the dehydrogenase from *E. coli* it was found that the compound was only a weak competitive inhibitor ($IC_{50} \sim 10$ mM). α -Methyl-DAP (93) was also a poor inhibitor.¹¹⁴ These findings helped to reinforce the theory that *meso*-DAP decarboxylase shows high specificity for its natural substrate *meso*-DAP (6).

Chapter Three: Synthesis of Analogues of Aspartic Acid β -Semialdehyde

3.1 Introduction

As discussed in chapters one and two the role played by aspartic acid β -semialdehyde (ASA) (23) in the biosynthesis of several amino acids is of the utmost importance. ASA (23) is an intermediate in the production of threonine (24), isoleucine (25), methionine (26) and lysine (1).

The DAP pathway to L-lysine (1) in bacteria utilises ASA (23) as one of the starting materials from which L-lysine (1) is synthesised. The research of our group in Glasgow has focused on the condensation of ASA (23) with pyruvic acid (32) catalysed by DHDPS to form dihydrodipicolinate (31). This is one of the most interesting steps in the biosynthetic pathway to L-lysine (1).

The use of ASA (23) as a starting material for the synthesis of more complex and unnatural amino acids has been reported in the literature recently.¹⁴⁹ The aldehyde function of the molecule is a very good handle upon which to perform a wide variety of synthetic modifications.

The research in Glasgow required a supply of ASA (23) which could be used in the testing of the potential inhibitors made within the group. The first reported synthesis of ASA (23) was by Black and Wright in 1975.¹⁵⁰ They prepared ASA (23) by the treatment of an acidic solution of allylglycine (94) with ozone at low temperature. They presented little evidence for the formation of ASA (23), stating only that the product was reduced by homoserine dehydrogenase. The synthesis of Black and Wright was the basis on which Dr D. Tudor prepared ASA (23) as a solid of known purity. Dr D. Tudor reported the synthesis of ASA (23) as its trifluoroacetate salt in four steps from allylglycine (94) with an overall yield of 14%. In this work the synthesis has been improved and now has an overall yield of 48%.

This chapter will detail the improved synthesis of ASA (23) and then discuss the synthesis of various alkylated derivatives of ASA (23) designed to be inhibitors of DHDPS. The chapter will start with an overview of the synthesis of α -amino acids and the reactions involved, then a brief discussion of protecting groups in the context of amino acid synthesis will be given. The chapter will conclude with a discussion of the compounds prepared.

3.2 Synthetic procedures for the production of α -amino acids

The isolation and synthesis of novel α -amino acids will continue to be one of the most important areas of active research. There are a vast number of methods by which α -amino acids have been synthesised which are described in the literature.^{151,152} There are three main areas into which the synthetic reactions towards amino acids fall. These are alkylation of glycine equivalents; condensation and substitution reactions by which the amino or carboxyl groups are introduced to complete the synthetic procedure; and the rearrangement of suitable substrates to form α -amino acids. Each of these synthetic strategies will be discussed separately in this section. A review by O'Donnell details the most recent advances in the preparation of α -amino acids.¹⁵³

There has also been much effort into the synthesis of α -amino acids by asymmetric methodology. The result of this is that there are now a large number of reliable methods by which α -amino acids can be prepared in high enantiomeric excess.¹⁵⁴ This discussion will only briefly touch on this subject as it is in itself a large area of research.

Alkylation of glycine derivatives to give α -amino acids

There are two major types of starting materials for this type of reaction. The first are *N*-acylaminomalonates which are easily alkylated by virtue of their acidic hydrogens at the α -position. The second type of starting material are benzylidene glycine esters which are again acidic at the α -position and undergo facile alkylation with reasonably weak bases.

A typical procedure for the alkylation of diethyl acetamidomalonate (95) involves the reaction of the appropriate alkyl halide with the diester (95), see **figure 52**. In the presence of a base such as sodium ethoxide the acetamidomalonate is deprotonated to form (96) and then displaces the halide ion from the alkyl halide in an S_N2 reaction. The esters are removed by hydrolysis of (97) using aqueous sodium hydroxide. This yields a malonic acid derivative (98) which is then decarboxylated by heating in water to give the desired amino acid (99). The side chain required must be inert to the harsh hydrolysis conditions at the end of the synthesis, and this can restrict the applicability of this route to certain types of functional groups.

The use of benzylideneglycine esters was all but abandoned due to the over-alkylation seen with these compounds. The remaining hydrogen was too acidic

and the products isolated consisted of a mixture of mono- and di-alkylated derivatives. Alkylation under phase transfer conditions was introduced as a

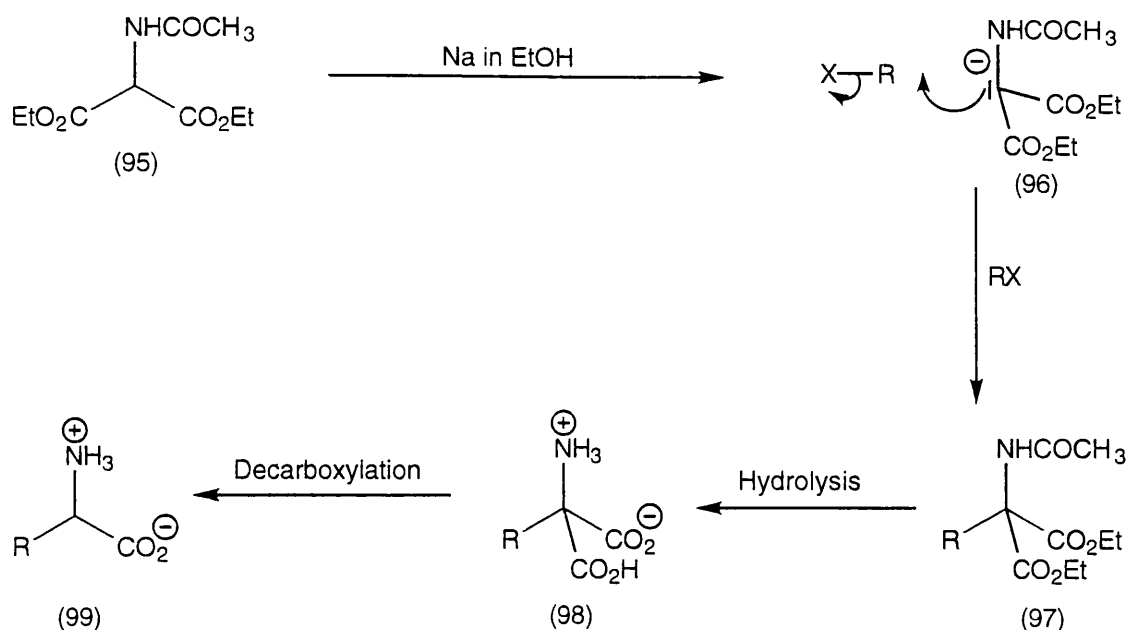


Figure 52: Alkylation of *N*-acetylacetamido malonates

method of alkylating these benzylideneglycine esters selectively to give exclusively the mono-alkylated product. The compound of most use is (*N*-diphenylmethylene)aminoacetonitrile, since the corresponding glycine ester was found to undergo a certain amount of ester hydrolysis under the reaction conditions. (*N*-Diphenylmethylene)aminoacetonitrile (100) is an active methylene compound and is acidic due to the stabilisation of the negative charge by delocalisation into the π systems of the aromatic groups and the nitrile. The alkylation is carried out as in **figure 53**. The resulting alkylated compound (101) can be easily deprotected by stirring in aqueous acid to remove the benzylidene protecting group to give (102) and then by further hydrolysis of the nitrile using sodium hydroxide to produce the amino acid (103).

This method relies on a quaternary ammonium species acting as a phase transfer catalyst. In these experiments the phase transfer agent used is generally benzyltriethylammonium chloride (BTEAC). The catalyst forms a tight ion pair with the hydroxide ion and escorts it into the organic layer where the hydroxide ion abstracts a proton from the active methylene compound (100). The catalyst escorts the subsequently released halide ion back to the aqueous layer, where the catalyst exchanges the halide for a hydroxide and the process begins again. The remaining hydrogen is not sufficiently acidic to be

appreciably deprotonated by aqueous sodium hydroxide and this explains the isolation of mono-alkylated compound as the major product.

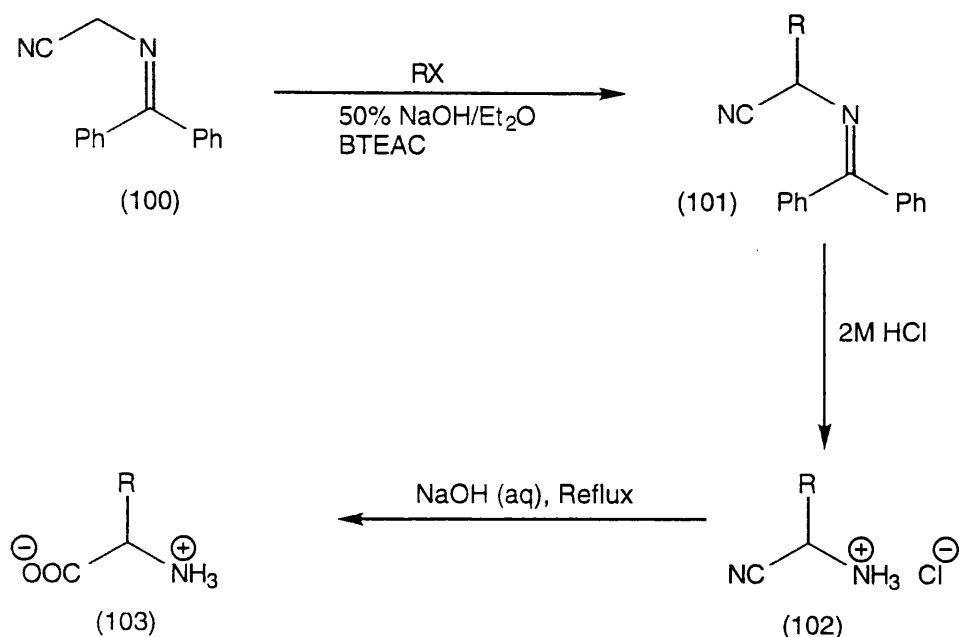


Figure 53: Alkylation of (diphenylmethylene)aminoacetonitrile

Condensation and substitution reactions to produce α-amino acids

This methodology is exemplified by the Strecker synthesis which involves the condensation of an aldehyde (104) with ammonia, or other amine, to give an imine (105) and then reaction with sodium cyanide to give an α-aminoalkanenitrile (106) which can be hydrolysed to the α-amino acid (103) using sodium hydroxide, see **figure 54**. The nitrile is quite easily hydrolysed to the acid and this makes the Strecker synthesis a versatile method for producing amino acids. The reaction is only limited by the production of the starting aldehyde which is not always an easily available starting material.

Amination of α-halo acids

The alkylation of α-halo acids (107) is one of the most general and high yielding of the preparations of α-amino acids available, see **figure 55**. The method is convenient and general as long as the α-halo acid can be prepared from one of the many methods known.

Rearrangement reactions leading to α-amino acids

A number of the classical rearrangements of organic chemistry can be employed in the synthesis of α-amino acids. The Hofmann, Curtius and

Schmidt rearrangements can all give α -amino acids by careful choice of starting

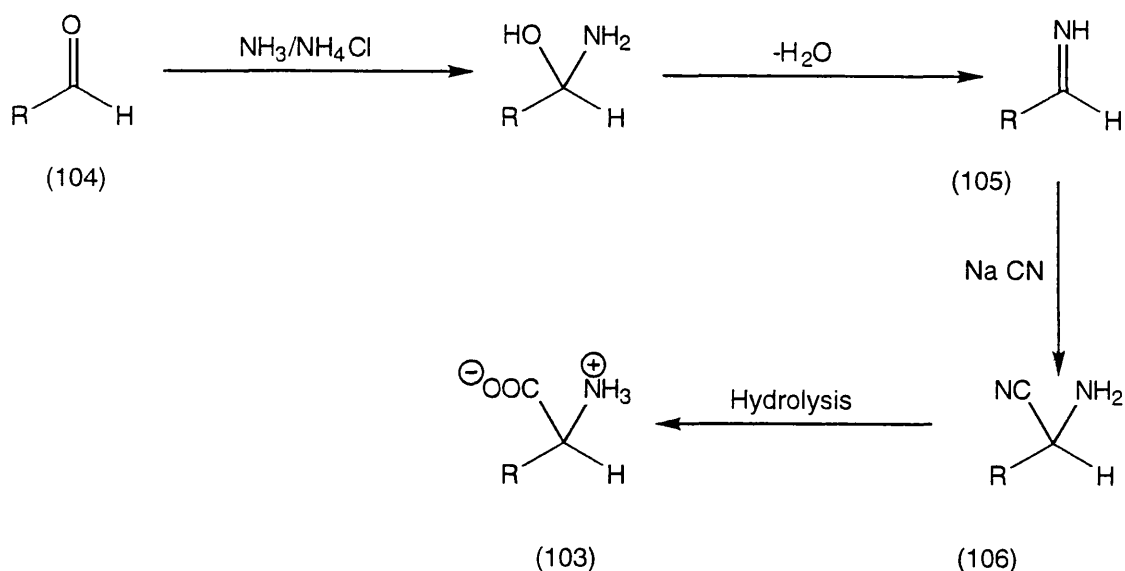


Figure 54: Strecker synthesis of α -amino acids

material, see **figure 56**.¹⁵⁵ The Hofmann reaction involves the rearrangement of amides (108) via the isocyanate (109), formed by the migration of an R group from carbon to nitrogen in a 1,3-migration. The leaving group in this case is a bromide ion. The Schmidt rearrangement involves acyl azides (110), formed by reaction of an acid (111) with hydrazoic acid. The R group migration is driven by the loss of a molecule of nitrogen. The Curtius rearrangement proceeds through an analogous acyl azide to that of the Schmidt rearrangement formed by reaction of an acyl hydrazide (112) with nitrous acid. The isocyanate is then hydrolysed by treatment with aqueous acid and decarboxylated to form the amino acid.

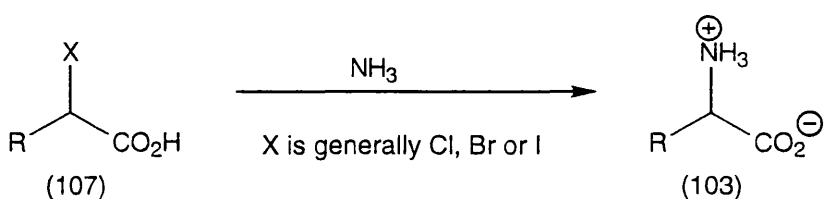


Figure 55: Amination of α -halo acids

Asymmetric synthesis of α -amino acids

Numerous methods have been developed for the preparation of α -amino acids in high enantiomeric purity. A large number of these reactions rely on the interconversion of one α -amino acid into another using the natural optical activity of the α -amino acid (both *R*- and *S*-forms of natural and some unnatural amino acids can be purchased). This makes the synthesis of one enantiomer much

easier as the chiral synthesis has already been carried out by the bug or plant that originally manufactured the α -amino acid.

A general method that allows construction of amino acids with very high enantiomeric excess is the method developed by Schollkopf.¹⁵⁶

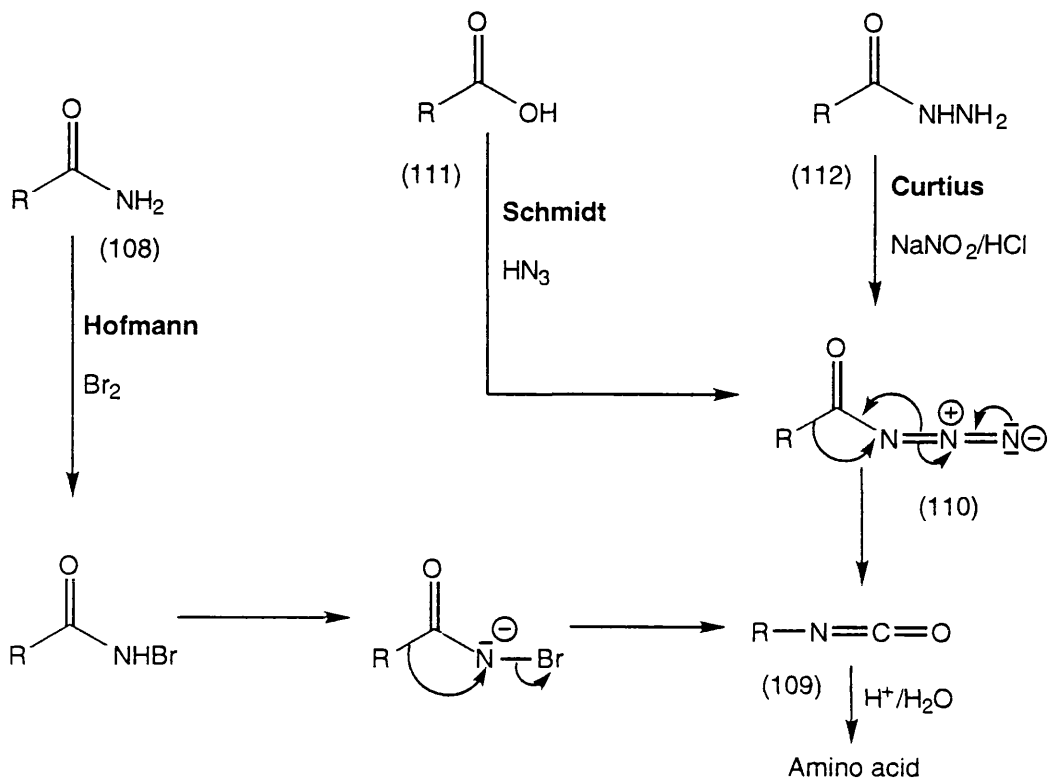


Figure 56: Rearrangement reactions forming α -amino acids

The method of Schollkopf involves the reaction of alkyl halide with lithiated bis-lactim ethers of 2,5-dioxopiperazines. The heterocycle used is based on a simple amino acid such as glycine or alanine and the other half of the heterocycle is made up of a valine molecule acting as the chiral auxiliary, see **figure 57**. The most common bis-lactim ether (113) in use is made from glycine and L-valine. The heterocycle is acidic and the hydrogen is easily removed by *n*-butyllithium to give (114). This is an almost planar species which can be alkylated from either face. The high degree of selectivity can be understood by noting that the face on which the valine side chain resides is much more sterically crowded than the other face. Hydrolysis of the resulting alkylated dioxopiperazine (115) under mild acidic conditions liberates the newly formed amino acid (116) and the chiral auxiliary (117). The main disadvantage of this reaction is that it can sometimes be difficult to separate the chiral auxiliary from the newly formed amino acid, especially if they are similar in size and shape.

There are numerous other methods for the chiral syntheses of α -amino acids described in the literature.

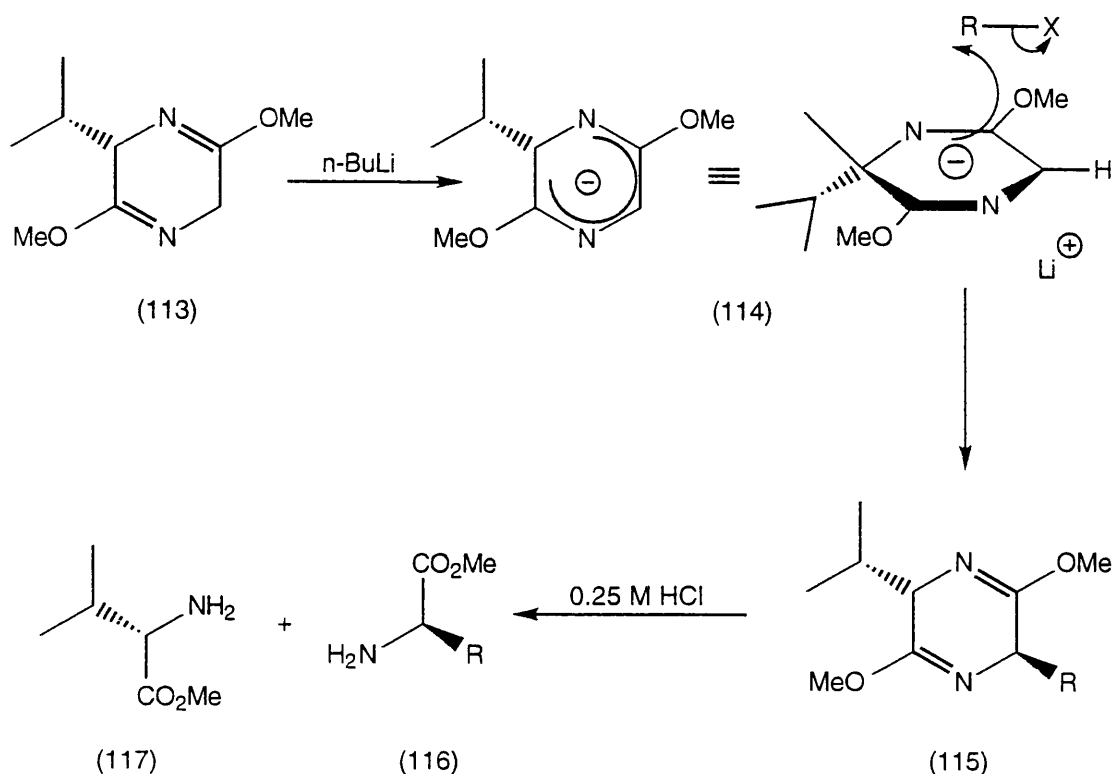


Figure 57: Schollkopf's chiral synthesis of α -amino acids

3.3: Protecting groups in α -amino acid chemistry

It is often necessary to mask the reactive amino and carboxyl groups of α -amino acids to allow synthetic manipulation of the side chains or to form amide bonds. These protecting groups are required to be stable to a large variety of reaction conditions. Another important feature of a protecting group is that the protection and deprotection steps should be high yielding and not require harsh conditions which may affect other groups of the amino acid.

The protecting groups that are used most for the protection of the amino group are the *t*-butoxycarbonyl (BOC) and the benzyloxycarbonyl (Cbz or Z). The carboxyl function also has numerous available protecting groups including *t*-butyl esters and benzyl esters. These groups fulfil all of the stated requirements for protecting groups.

The two most common reagents used for the formation of BOC protected amino acids are di-*t*-butyldicarbonate (118)¹⁵⁷ and 2-*t*-(butoxycarbonylimino)-2-phenylacetonitrile (119) (BOC-ON), see **figure 58**.¹⁵⁸ These groups are normally put on under mild basic conditions and yields are very good, generally

above 80% using both reagents. The mechanism for the formation of the BOC protected amino acids is shown in **figure 58**.

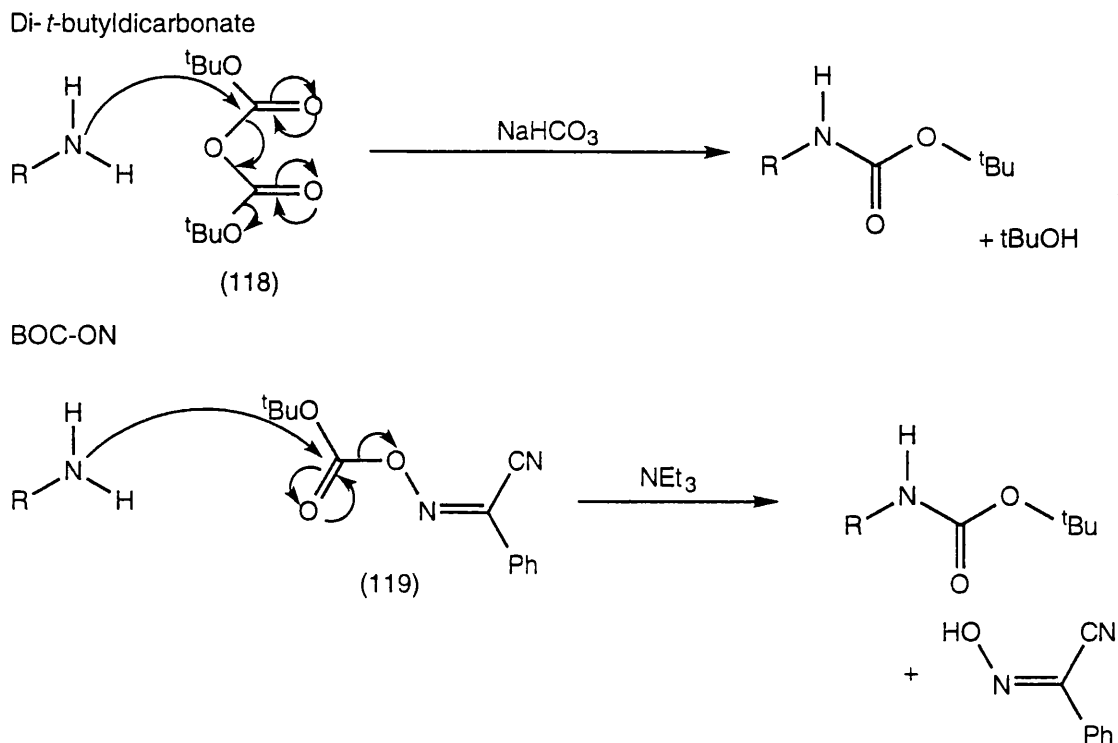


Figure 58: Formation of a BOC protected α -amino acid

BOC groups are cleaved under mild acidic conditions, due to the stability of the *t*-butyl cation which is an intermediate of the deprotection. The deprotection is usually carried out using trifluoroacetic acid at room temperature and yields are generally high.¹⁵⁹ The mechanism of removal is analogous to the $A_{AL}1$ mechanism for ester hydrolysis.

The carboxyl group can also be protected using a *t*-butyl group in the form of the *t*-butyl ester. This ester is formed by reacting the free acid group with isobutylene gas and concentrated sulfuric acid.¹⁶⁰ This again uses the stability of the *t*-butyl cation which is attacked by the hydroxyl of the acid group. Yields above 85% are normal for the formation of *t*-butyl esters.

Cleavage of *t*-butyl esters occurs under the same mild acidic conditions that cleave the BOC group. The mechanism in this case is the $A_{AL}1$ mechanism and involves the formation of the *t*-butyl cation as the alkyl oxygen bond is cleaved. The similar cleavage conditions for the BOC group and *t*-butyl ester have made this pairing a popular choice for many reactions involving α -amino acids.

The other major amino protecting group is the benzyloxycarbonyl or Cbz group (120). This is prepared by reacting the free amino group with benzyl

chloroformate (121) under mildly basic conditions, see **figure 59**. This again is a good, stable protecting group for the amino group with high yields for its formation, usually greater than 90%.

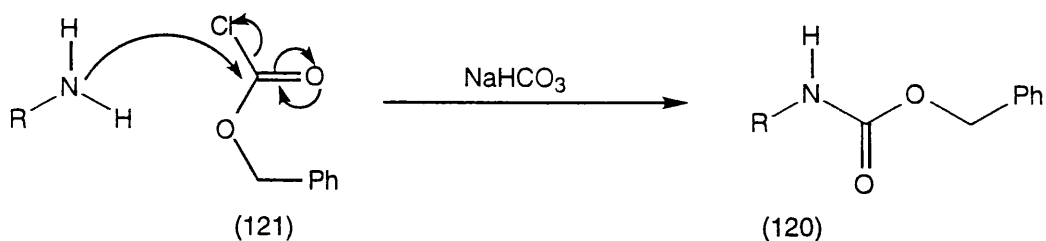


Figure 59: Formation of a Cbz protected α -amino acid

The Cbz group is stable under mild acidic conditions. It can however be removed by catalytic hydrogenation with a number of catalysts and under numerous sets of conditions. Another method of cleavage known for the Cbz group is cleavage by the Lewis acid trimethylsilyl iodide, see **figure 60**.

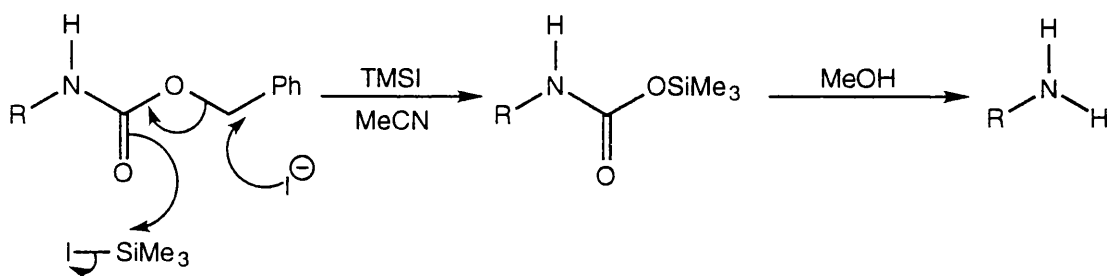


Figure 60: Removal of a Cbz group using a Lewis acid

The carboxyl group is also commonly protected as its benzyl ester which is usually prepared by reacting benzyl bromide with the free carboxylate. This is a slow reaction and the development of the *p*-methoxybenzyl ester (PMB) as a carboxyl protecting group grew out of the need to find a better substitute. The *p*-methoxybenzyl ester is formed by reacting the carboxylate with the more reactive *p*-methoxybenzyl chloride (122) under basic conditions, see **figure 61**. The PMB ester, unlike the benzyl ester, is cleaved under mild acidic conditions.

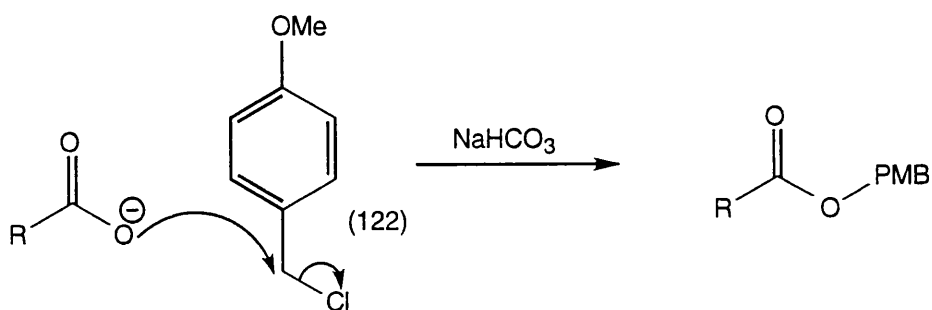


Figure 61: formation of the PMB ester of an α -amino acid

3.4: Synthesis of Aspartic acid β -semialdehyde

As reported earlier aspartic acid β -semialdehyde (ASA) (23) was prepared by Black and Wright.¹⁵⁰ They treated allylglycine with ozone at $-78\text{ }^{\circ}\text{C}$ in acidic solution and obtained ASA (23) in solution, but no isolation was attempted. Black and Wright also did not quote any chemical or spectroscopic evidence for the formation of ASA (23).

This was not a satisfactory situation to begin a detailed investigation of a biochemical pathway. Within our group at Glasgow a former co-worker Dr D. Tudor repeated the Black and Wright procedure in an attempt to characterise the products of the ozonolysis. He found that ASA (23) was indeed produced in varying amounts and that aspartic acid, resulting from over-oxidation, could also be identified.

This was not a good method for the synthesis of large quantities of ASA (23) needed to carry out the biochemical studies. Dr D. Tudor therefore developed a controlled synthesis of ASA (23) as shown in **figure 62**.⁷⁰ This was based on the ozonolysis of allylglycine that Black and Wright had used; however the amino acid was doubly protected to enable organic solvents to be used.

Allylglycine (123) was protected at the amino and carboxyl groups with the BOC group and a *t*-butyl ester respectively. The carboxyl protection was the first step and gave the *t*-butyl ester (124) in only 34% yield, much lower than most reported preparations. This was isolated as the hydrochloride salt which was neutralised *in situ* and the BOC group was introduced using di-*t*-butyldicarbonate to give doubly protected allylglycine (125). The yields from this step, in general greater than 90%, were in keeping with the normally high yields for amino protection using the BOC group. Ozonolysis proceeded well with no side products and after a reductive work up and removal of the triethylamine *N*-oxide by chromatography, compound (126) was isolated as an oil in 90% yield. Treatment of (126) with trifluoroacetic acid (TFA) gave after one hour a 74% yield of a yellow solid, which by NMR spectroscopy was identified as the trifluoroacetate salt of ASA (23). The ASA (23) was isolated as a hydrate with no signal for the aldehyde proton in the ^1H NMR spectrum, instead a triplet at δ 5.1 was found representing the C-4 proton.

The major problem with this synthesis was the low yield of the *t*-butyl ester from the initial step. This was a great problem especially as the allylglycine was a

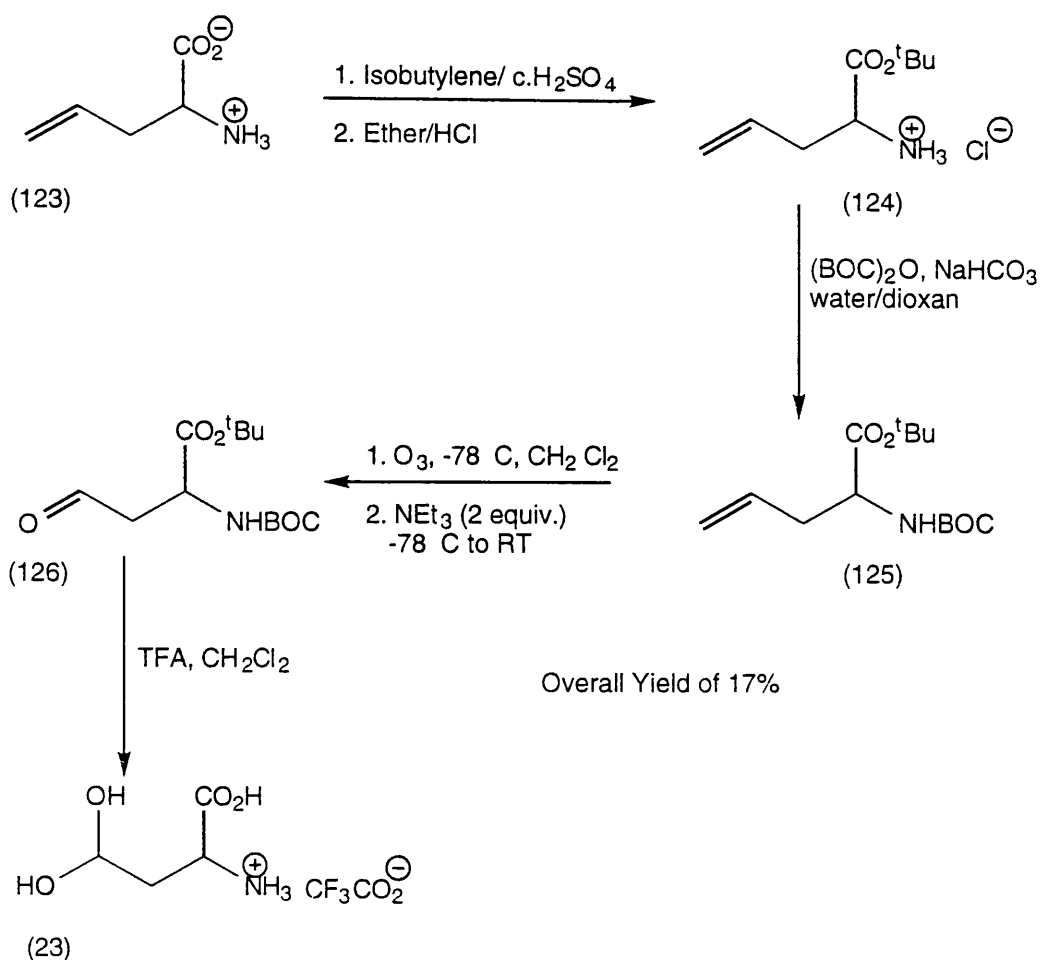


Figure 62: Synthesis of aspartic acid β -semialdehyde⁷⁰

reasonably expensive starting material. A new method of preparing ASA (23) was required that removed the problem of the low yielding esterification. The problem was solved by using the *p*-methoxybenzyl ester which could be put in place in much higher yields and led to a more efficient synthesis, see figure 63.

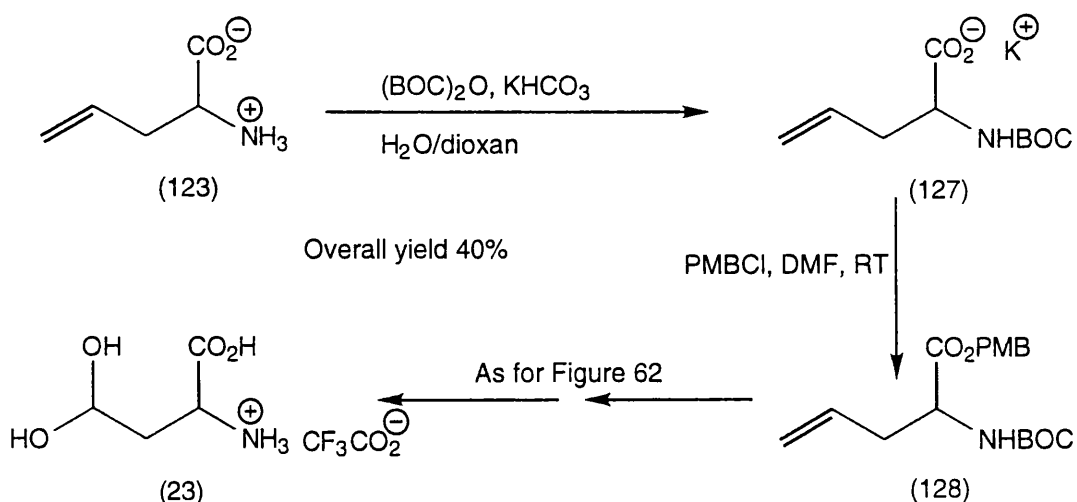


Figure 63: *p*-Methoxybenzyl ester route to aspartic acid β -semialdehyde

Allylglycine (123) was treated with di-*t*-butyldicarbonate in aqueous potassium bicarbonate to produce (127) in good yield. Compound (127) was treated with *p*-methoxybenzyl chloride in DMF to produce the doubly protected allylglycine (128) in 95% yield. The rest of the synthesis was the same as that for the *t*-butyl ester, but the overall yield was now 40%.

The material produced by the *p*-methoxybenzyl ester route was identical to that from the *t*-butyl ester route by NMR spectroscopy. This was not the case in the UV assay used for the inhibitor studies. The material produced by the *p*-methoxybenzyl ester route normally produced an assay cocktail with a background absorbance of about 1.7-1.8 absorbance units. This was compared to the cocktail made using ASA (23) prepared by the *t*-butyl ester route. This gave a much lower background absorbance of 1.4-1.5 absorbance units. This suggests that some impurity is present in the ASA (23) prepared by the *p*-methoxybenzyl ester route. The assay system used for studying reactions with DHDPs was therefore carried out with a high background absorbance. The lower the background absorption the more reliable the data obtained from the assay system should be. It was therefore preferable to use ASA (23) produced via the *t*-butyl ester route.

It was thus desirable to increase the yield of the *t*-butyl ester preparation to greater than 70%. The main problem of the reaction as it was carried out was the formation of an unidentified polymer of isobutylene, which used up most of the isobutylene in the reaction. Maintaining the temperature below -50 °C for seven hours resulted in improved yields of the *t*-butyl ester (124). The use of low temperatures retarded the formation of the isobutylene polymer. This allowed more “free” *t*-butyl cation in the organic layer for the carboxylate to attack. Using this procedure it was possible to obtain almost quantitative yields of the *t*-butyl ester (124) of allylglycine, see **figure 64**.

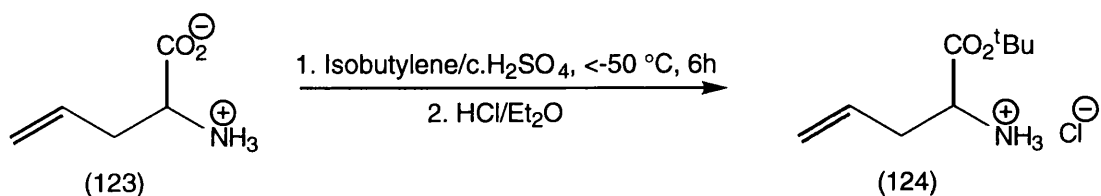
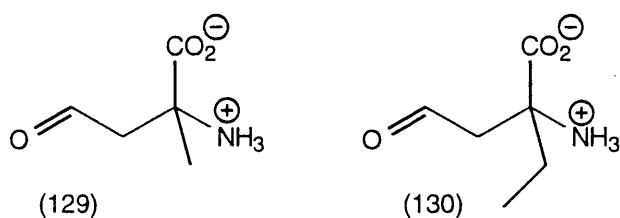


Figure 64: Improvement in the yield of the *t*-butyl ester preparation

3.5: Preparation of alkylated aspartic acid β -semialdehyde derivatives

There was methodology within the group for the synthesis of α -amino acids by the method of O'Donnell and Eckrich¹⁶². This procedure involved the alkylation of *N*-(diphenylmethylene)aminoacetonitrile using phase transfer conditions as outlined in section 3.2. The plan was to construct two simple α -alkylated amino acids to test as inhibitors of DHDPS. They might also act as substrates and so might be used for biotransformation experiments. The compounds chosen were the α -amino acids (129) and (130). They are methyl- and ethyl-substituted derivatives of ASA (23).



The starting point for both of these α -amino acids was, as mentioned above, *N*-(diphenylmethylene)aminoacetonitrile (100). This was dissolved in toluene and 50% aqueous sodium hydroxide was added as a base. To this was added BTEAC and the two phase system was stirred vigorously. The alkylating agent, allyl bromide, was added slowly over about an hour. The resulting product was found to be a mixture of the mono- (131) and di-alkylated product (132), see **figure 65**. The di-alkylated product was the minor component by a small margin. Using less allyl bromide helped to decrease the yield of di-alkylated product, but it was still a contaminant. This di-alkylated product is being investigated by Dr. P. Mallon as the precursor to possible inhibitors of DHDPS.

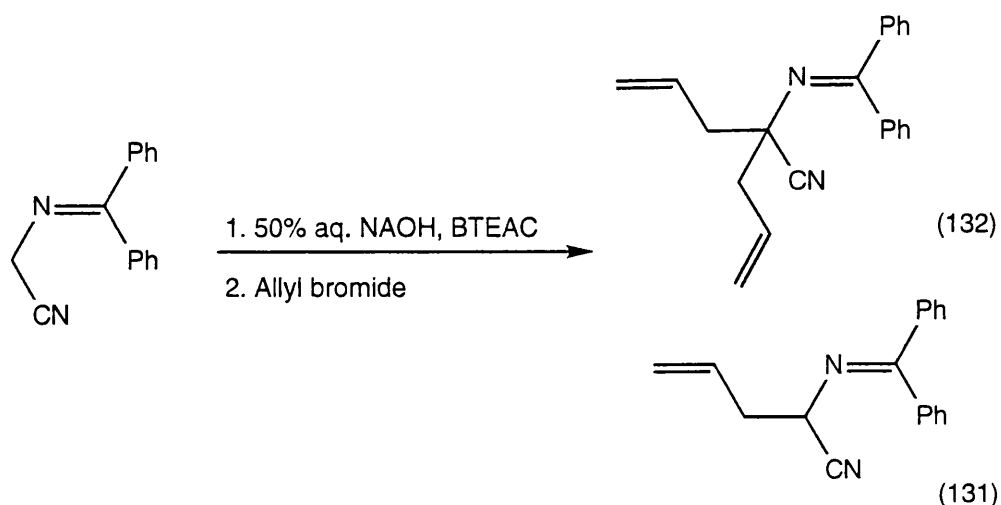


Figure 65: Alkylation of *N*-(diphenylmethylene)aminoacetonitrile

Two methods were found to alleviate this problem, the first was to carry out the proposed scheme of work the other way round, see **figure 66**. If methylation or ethylation is carried out first before alkylation with allylbromide, the mono-alkylated species (133) and (134) are not as likely to be further alkylated. This is due to the lower reactivity of the alkylating agent when compared to allyl bromide. The mono-methyl compound (133) was isolated in 90% yield and the mono-ethyl (134) was isolated in 75% yield. These were then alkylated with allylbromide to produce the protected nitriles (135) and (136).

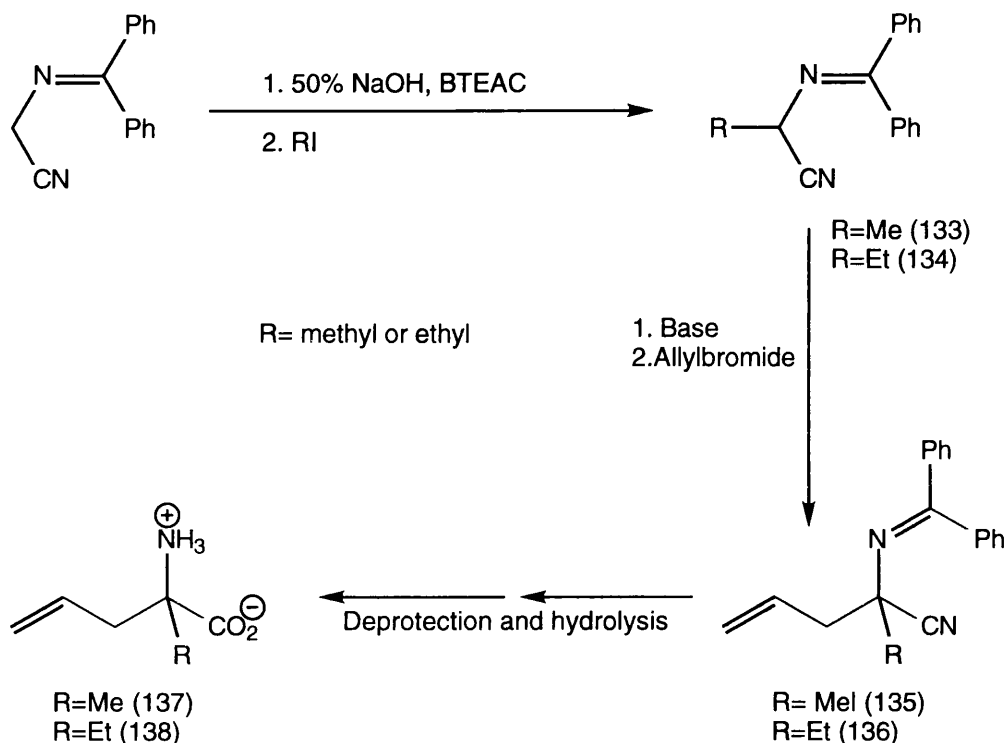


Figure 66: Scheme of work to produce the α -alkylated amino acids

The second method found to alleviate the di-alkylation problem was to use 20% aqueous sodium hydroxide. This allowed the preparation of the mono-alkylated product (132) in 91% yield.

The second alkylation was attempted by the procedure of O'Donnell and Eckrich¹⁶². The mono-alkylated product was to undergo a second phase transfer alkylation using powdered potassium hydroxide as the base. Under these conditions only starting material was recovered.

The di-alkylated compounds were prepared by using lithium di-isopropylamide (LDA) as the base. The α -methyl nitrile (135) was prepared in 90% yield from the mono-alkylated compound (133). The α -ethyl nitrile (136) was prepared in 88% from (134). The best evidence for the formation of these di-alkylated compounds was the disappearance of the signal for the α -proton in the ^1H

NMR spectrum. In the starting material there was a triplet at δ 4.2 which corresponds to the 2-H. In both of the di-alkylated compounds this signal had disappeared.

Deprotection of compounds (135) and (136) involved the removal of the benzylidene protecting group first. This group is extremely acid sensitive and was removed by stirring in 2M hydrochloric acid for two hours. The yields of the free amino compounds were good, above 80% for both (139) and (140). The nitriles were hydrolysed to produce the α -amino acids (137) and (138). This was achieved by heating the compounds at reflux in 10% sodium hydroxide for eighteen hours, see **figure 67**. The α -amino acids were isolated together with an appreciable amount of sodium chloride from the hydrolysis of the nitriles. This was not removed and all subsequent reactions were carried out with the salt present.

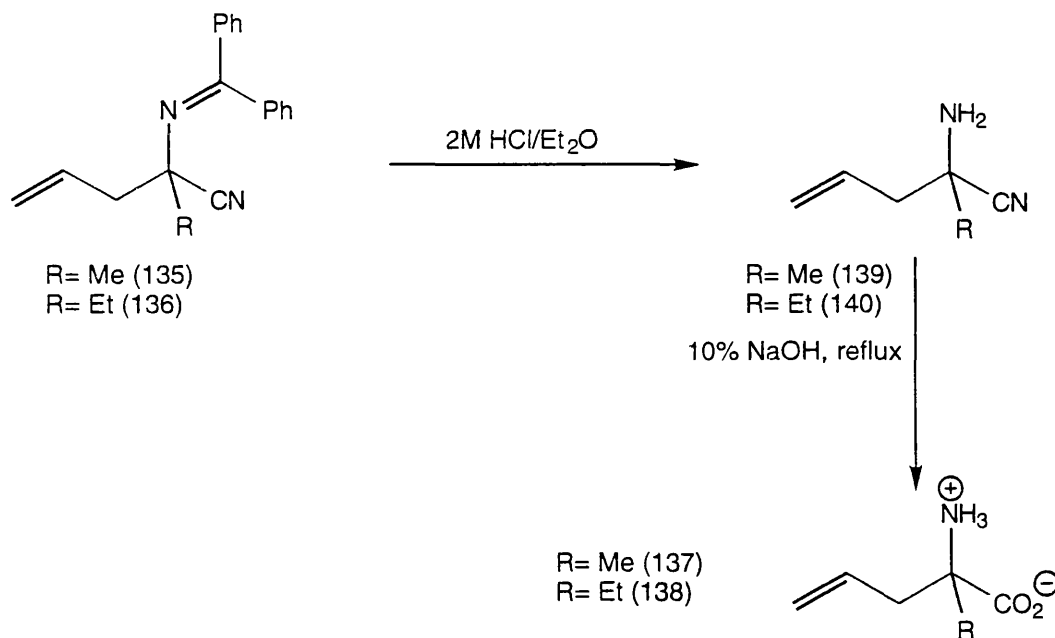


Figure 67: Deprotection of the α -alkylated aminonitriles

The ^1H and ^{13}C NMR spectra of compounds (137) and (138) were consistent with the α -amino acid structure of these compounds. As can be seen in **figures 68a and b**, which show the ^1H NMR spectrum of (137) and the ^{13}C NMR spectrum of (138) in D₂O the compounds contain mainly the amino acid with a small proportion of aqueous soluble impurity.

The ^1H NMR spectrum of (137) showed the α -methyl group at δ 1.45 as a singlet as expected. The CH₂ group of the amino acid was split into a complex pattern and was recorded at δ 2.5. The CH₂ might be expected to be split into an ABX system due to the fact that the two hydrogens on C-3 are

diastereotopic. This coupling pattern is further split by a coupling to the CH₂ of the terminal alkene. This coupling did not appear to be resolved in the ¹H NMR spectrum. The alkene hydrogens were found at δ 4.9 and 5.7, and were split into a complex multiplet. The ¹³C NMR spectrum revealed the position of the α-carbon to be δ 62. The carboxyl quaternary carbon appeared at δ 172.0.

The ¹H and ¹³C NMR spectra of compound (138) were similar to those of (137) in that the chemical shifts for the alkene signals were very similar. The α-carbon of the amino acid was found at δ 66 in the ¹³C NMR spectrum, with the carboxyl quaternary carbon being found at δ 174.5. The ¹H NMR spectrum showed signals at δ 0.75 and 1.7 for the α-ethyl substituent.

The mass spectra of both (137) and (138) showed molecular ion signals at *m/z* 129 and 143 respectively. Both compounds showed loss of their side-chains as the major pathway of fragmentation. The IR spectra showed the amino acid I and II bands at 1734 and 1636 cm⁻¹ for (137) and 1705 and 1625 cm⁻¹ for (138).

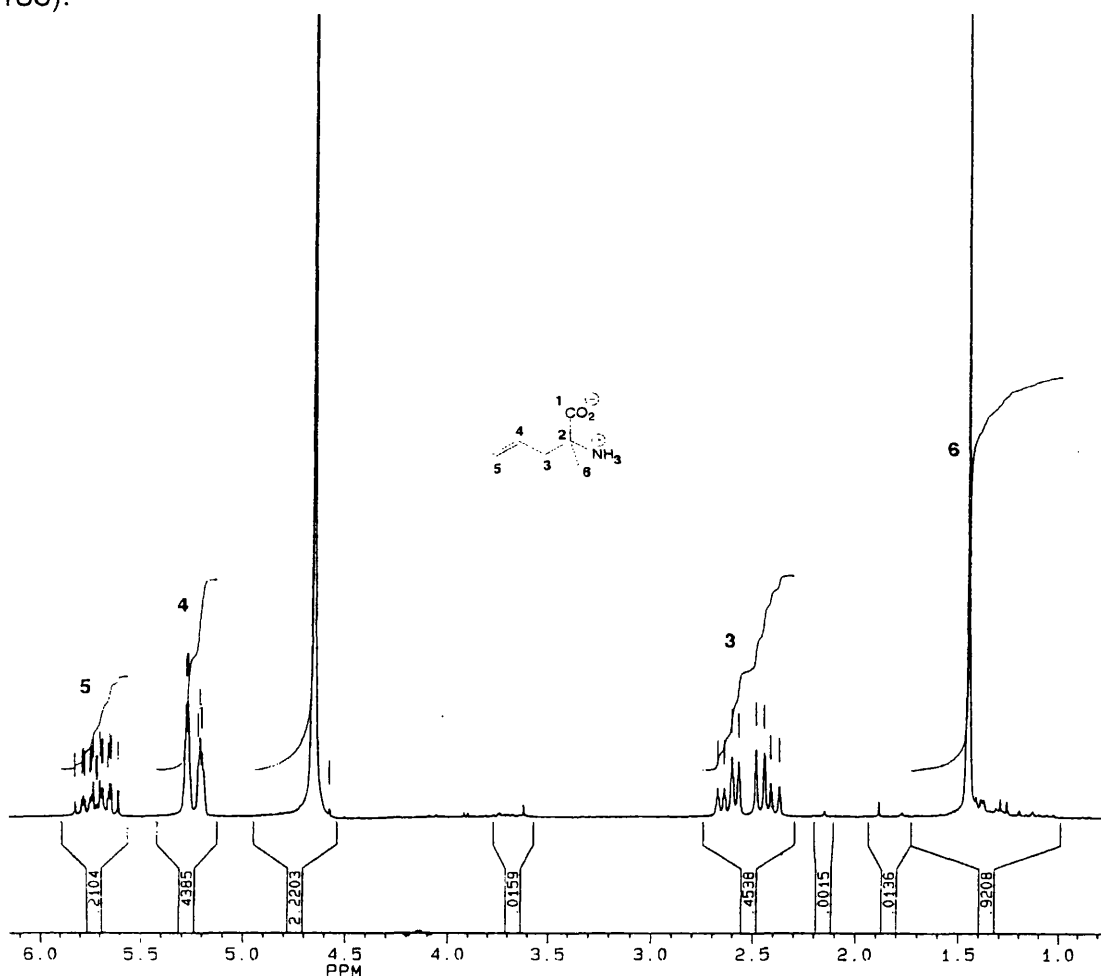


Figure 68a : ¹H NMR spectrum for compound (137)

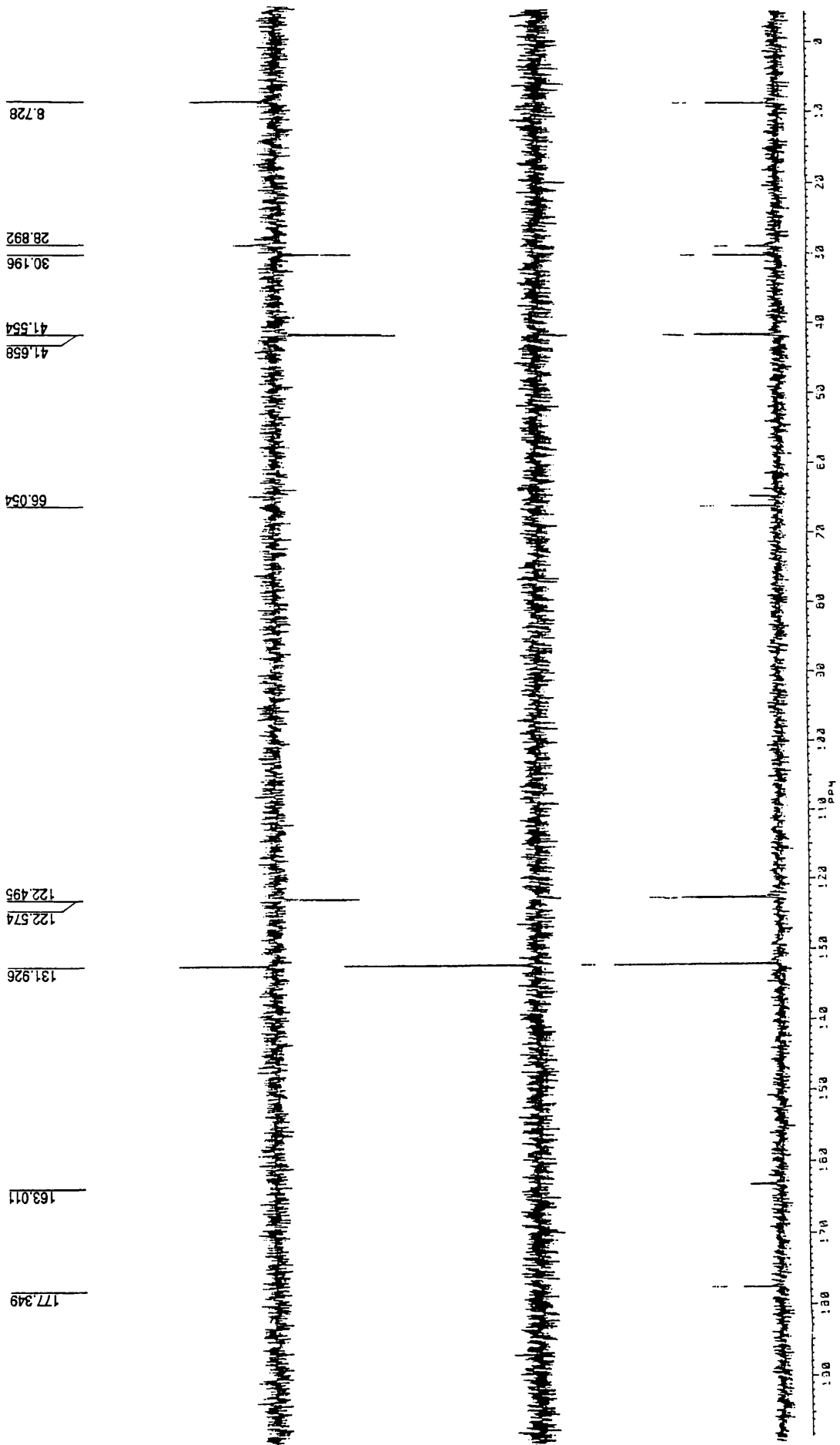


Figure 68b: ^{13}C NMR spectrum of compound (138)

The next stage involved the protection of the amino acids (137) and (138) at the carboxy and amino groups in preparation for the ozonolysis. Attempts to form the *t*-butyl ester were unsuccessful with only starting material being recovered. Attempts were also made to form the methyl ester at the α -carboxyl. Treatment of the amino acid in methanol with hydrochloric acid gas gave again only starting material. All attempts to make the *N*-BOC amino acids were also unsuccessful. It was initially thought that the nitrile group had not hydrolysed fully under the conditions used and that the compound isolated was the amide. This does not however explain the lack of reactivity of the amino group towards the BOC reagent.

An attempt to hydrolyse the amide, if indeed it was present, was made using barium hydroxide solution (0.5 M). Compound (137) was heated at reflux for six hours in barium hydroxide solution and then allowed to cool. The barium ions were removed by precipitation as barium carbonate using solid carbon dioxide. Upon removal of the water the amino acid was isolated as a pale solid. An attempt was made to prepare the methyl ester using methanol and hydrochloric acid gas. Only the starting amino acid was recovered from this reaction.

The failed attempt to prepare the α -methyl-ASA by this route was unexpected. No explanation for the low reactivity of compounds (137) and (138) towards the standard protecting conditions could be found.

Another route that was investigated was based on the alkylation of diprotected allylglycine (125), see **figure 69**. An initial attempt to alkylate compound (125) using LDA as a base and iodomethane as the alkylating agent had given a yield of about 10% of the alkylated material. This was promising enough to warrant further investigation considering the difficulties found with the other route to the compounds (137) and (138).

The diprotected allylglycine (125) was prepared as discussed previously. The alkylation of (125) was optimised by varying the reaction time and temperature to produce yields of the alkylated products of >70% after chromatography. Attempts to prepare the α -hydroxymethyl compound from paraformaldehyde failed to produce appreciable amounts of compound (143). Compounds (141) and (142) were isolated in 86% and 75% yields respectively. The α -methyl signal for compound (141) was found at δ 1.4 in the ^1H NMR spectrum, whereas the corresponding signals for the α -ethyl compound were found at δ 1.1 and 1.5. The signal at δ 1.5 for compound (142) was attributed to the CH_2

of the α -ethyl group and was found to be a multiplet for the diastereotopic protons.

Ozonolysis of compounds (141) and (142) produced the diprotected ASA derivatives (144) and (145) in 80% and 77% yields, respectively. The mechanism for the ozonolysis is shown in **figure 70**. The aldehyde signals were found at δ 9.7 and 9.75 in the ^1H NMR spectrum and at δ 198.1 and 201.4 in the ^{13}C NMR spectrum, respectively. No contamination by starting material was seen from the NMR spectrometry evidence, as the signals for the alkene group were absent from both the ^1H and ^{13}C NMR spectra.

Compounds (144) and (145) were deprotected fully in one step using trifluoroacetic acid in dichloromethane. Compound (144) gave a pale yellow solid (129) which showed no sign of an aldehyde peak by ^1H or ^{13}C NMR

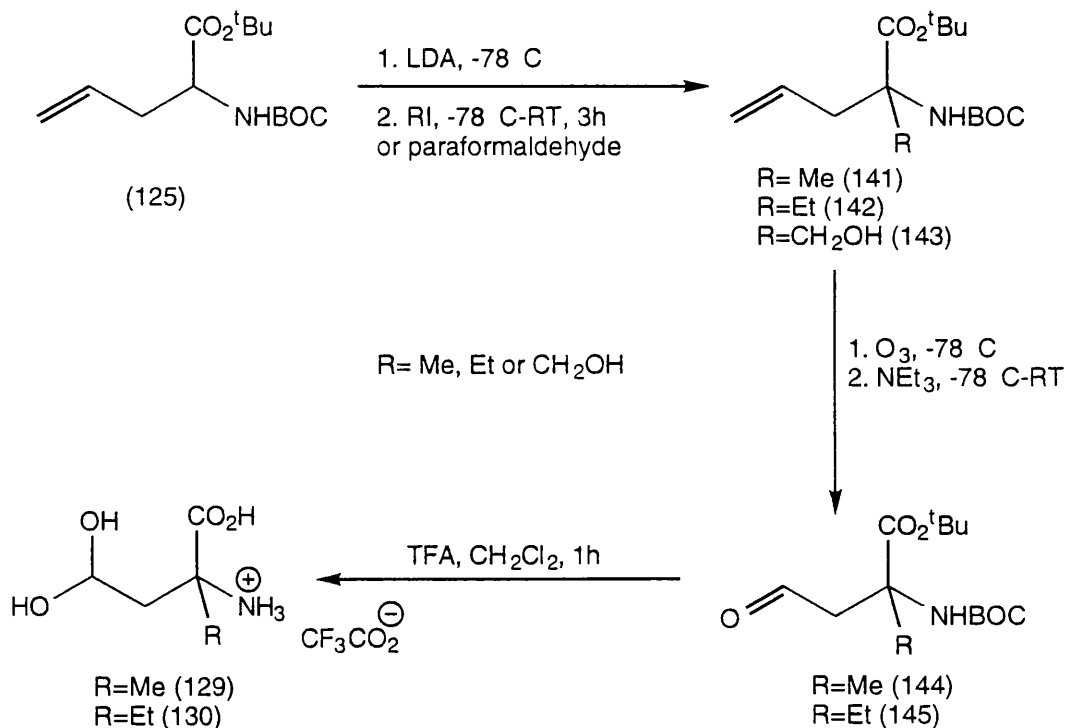


Figure 69: Alkylation of diprotected allylglycine using LDA

spectra. The compound was isolated as a hydrate as shown by the signal in the ^1H NMR spectrum at δ 4.9. The α -ethyl compound (130) was also isolated as a hydrate. Both compounds were tested with DHDPS and the results of the testing can be found in chapter seven.

3.6 *N*-Formyl aspartic acid β -semialdehyde

N-Formyl ASA (146) was first prepared by Tudor from allylglycine in four steps. The compound was never tested for substrate or inhibitor activity against DHDPS and it was decided to re-synthesise it in order to obtain the biological data. The compound was designed to bind and react with pyruvate present on the enzyme, but it should be unable to cyclise to DHDP (27) and may therefore act as an inhibitor.

The route by which compound (146) was synthesised is shown in **figure 71**. The coupling reagent used, dicyclohexylcarbodiimide (DCC), was not the same as that reported by Tudor. He used 1-(3-dimethylaminopropyl)-3-ethyl carbodiimide which was reported to have good water solubility and would be easily removed after the reaction. When the coupling was carried out using the original coupling reagent the the yield was less than 5%, and the product required further purification. DCC gave no such problems with a yield of (147), after chromatography, of 95%. The mechanism of the coupling is outlined in **figure 72**. The *N*-formyl hydrogen appeared in the ^1H NMR spectrum at δ 8.2 and the *N*-formyl carbonyl appeared at δ 160.5 in the ^{13}C NMR spectrum.

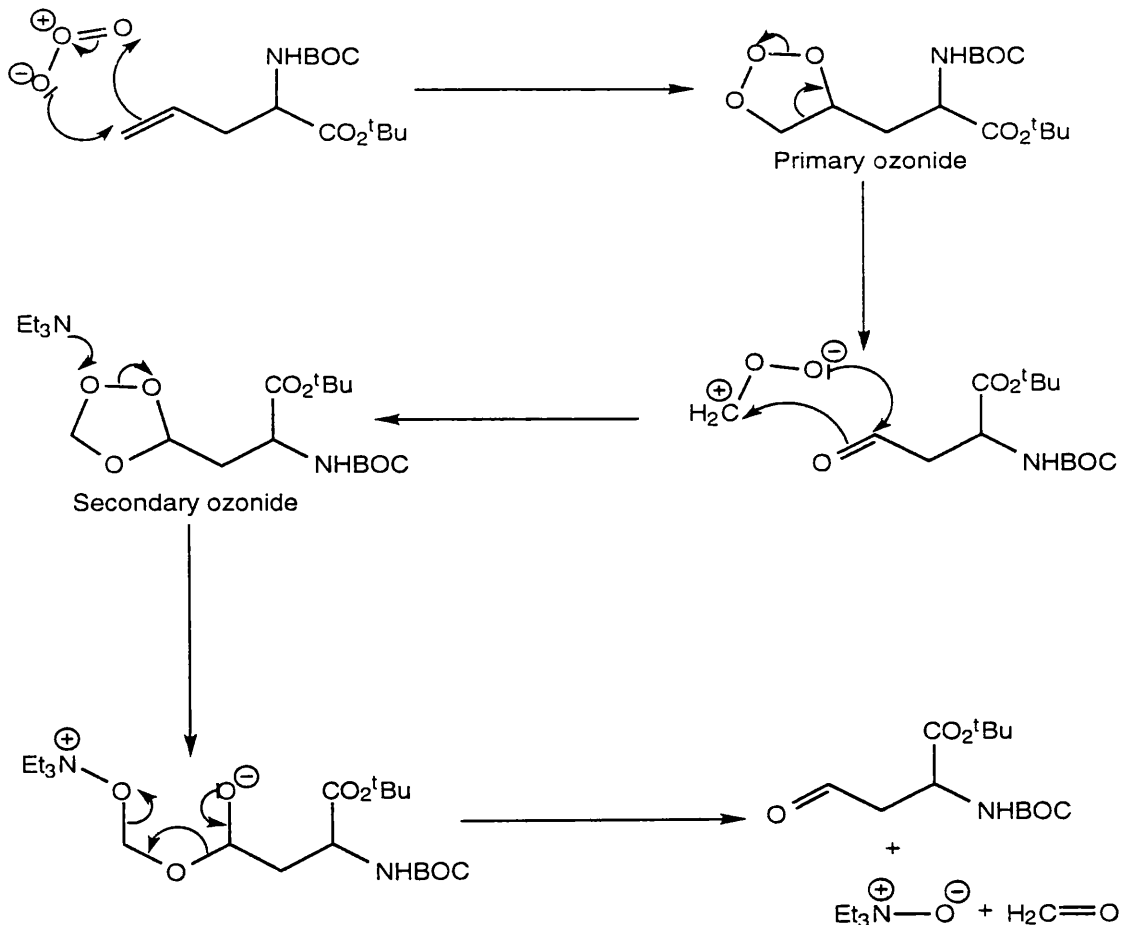


Figure 70: Mechanism for the ozonolysis of alkenes

Ozonolysis of the protected *N*-formylallylglycine (147) was carried out under the standard conditions of reductive work-up with two equivalents of triethylamine. Tudor had reported that no aldehyde was formed under these conditions; the only product he reported isolating was the ozonide of compound (147). The yield obtained from the ozonolysis of compound (147) was 75%, and the product was recovered as a colourless oil. The ^1H and ^{13}C NMR spectra were consistent with the formation of the aldehyde; the C-4H was found at δ 9.7 in the ^1H NMR spectrum and C-4 was found at δ 199.1 in the ^{13}C NMR spectrum. No signals were seen at δ 91.2 in the ^{13}C NMR spectrum, which Tudor attributed to the C-4 of the ozonide.

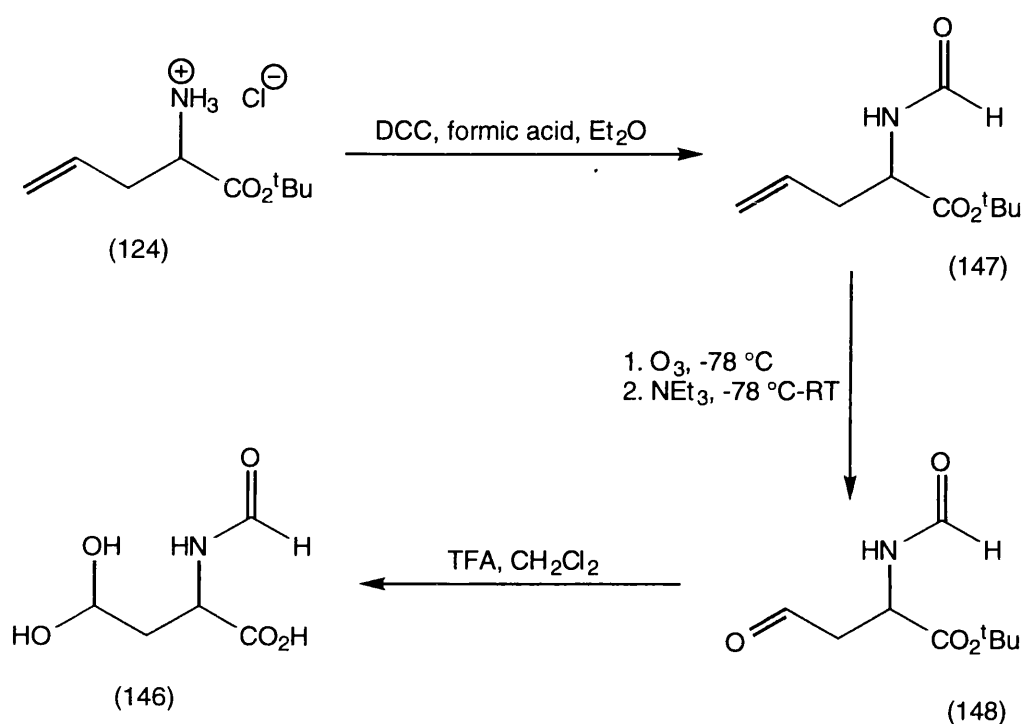


Figure 71: Preparation of *N*-formyl-ASA

N-Formyl ASA was deprotected using TFA to give a 92% yield of compound (146). The *N*-formyl proton was found at δ 7.7 in the ^1H NMR. The compound was found to exist as a hydrate after the deprotection, since no signal was found for the C-4 aldehyde in the ^1H or ^{13}C NMR spectra.

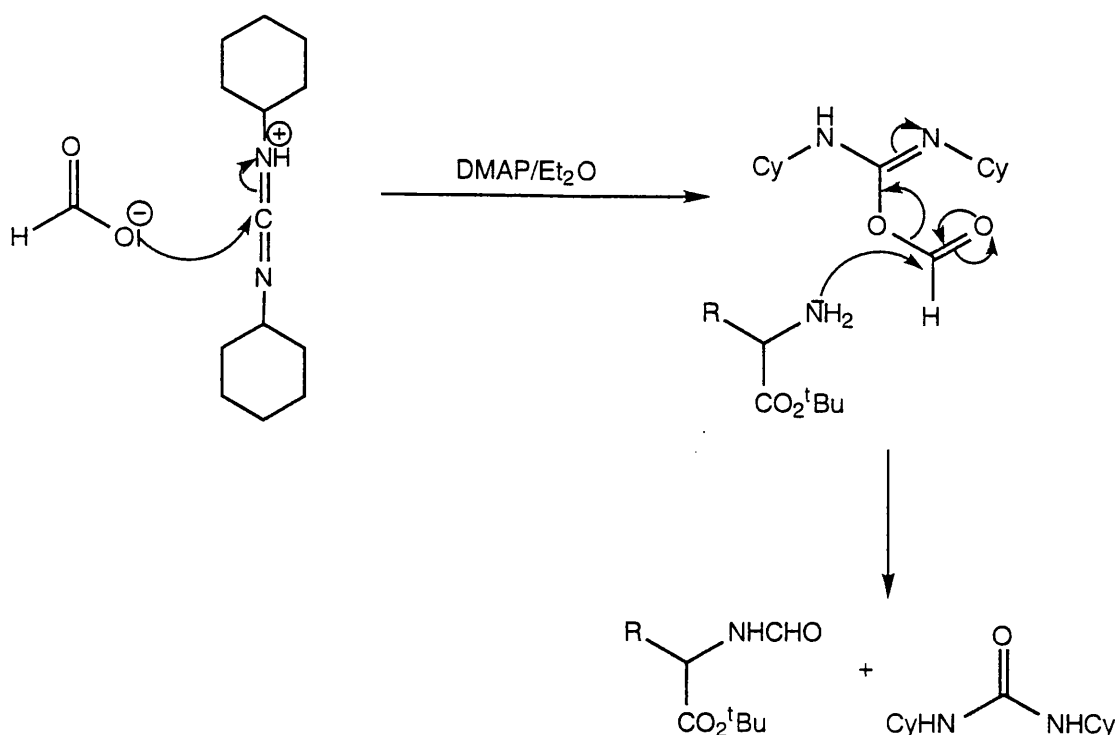


Figure 72: Mechanism of DCC coupling of (108) with formic acid

3.7 Succinic Semialdehyde

Succinate semialdehyde (149) lacks the amino group of ASA (23) and so may act as an inhibitor of DHDPS, as again it would be incapable of ring closure. Succinate semialdehyde may be prepared by the ozonolysis of pent-4-enoic acid (150). However in the light of the problems encountered in the ozonolysis of allylglycine it was decided that the best course of action would be to protect the carboxyl group, see **figure 73**.

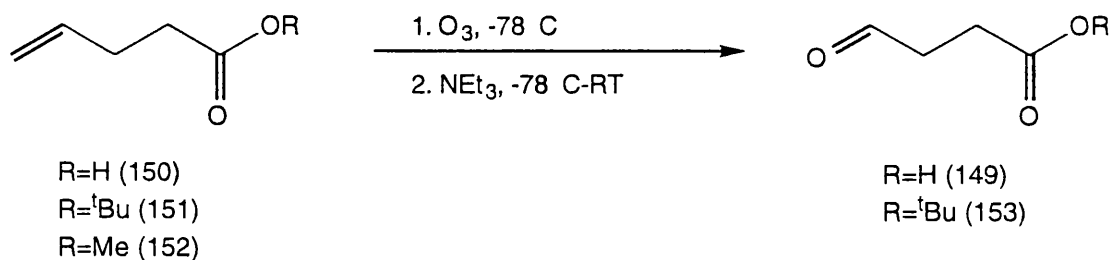


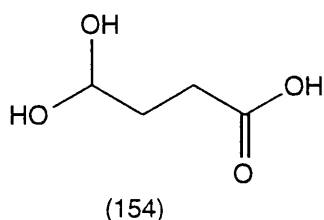
Figure 73: Formation of succinate semialdehyde

Treatment of pent-4-enoic acid (150) under the conditions used for the preparation of *t*-butyl esters led to the recovery of, after chromatography, *t*-butyl pent-4-enoate (151) in a 5% overall yield. Attempted optimisation of the conditions gave similar results with yields below 10% in all cases. Preparation of the methyl ester (152) of pent-4-enoic acid was attempted as an alternative to the *t*-butyl ester. The attempt involved treating compound (150) in methanol

with thionyl chloride. Yields were again disappointingly low, never rising above 10%.

Treatment of *t*-butyl pent-4-enoate (151) with ozone under the standard conditions gave (153) as a pale yellow oil in 78% yield. Pent-4-enoic acid (150) was also treated under the standard conditions for ozonolysis and produced a mixture of the aldehyde (149) and the hydrate (154) upon isolation and this was established by NMR spectroscopy.

The *t*-butyl ester (153) was deprotected using TFA and was isolated as a pale solid (154) in a yield of 65%, with NMR spectra closely resembling those recorded for the product of ozonolysis of unprotected pent-4-enoic acid.



3.8 Substitution of aspartic acid β -semialdehyde at the 3-position

The Claisen ester-enolate rearrangement was reported by Bartlett and Barstow to allow substitution of allylglycine systems at the 3-position.¹⁶³ They reported the conversion of (*E*)-2-butenyl-*N*-(*t*-butoxycarbonyl)amino acetate (156) into 3-methyl-2-(*t*-butoxycarbonylamino)pent-4-enoic acid (157), see **figure 74**.

This reaction was reported to proceed with relatively high diastereoselectivity, approximately 9 to 1 in favour of the methyl *trans* to the *N*-BOC group of the amino acid when written as shown in **figure 74**. This procedure would provide a good method by which to produce compounds with various combinations of methyl groups in the 2- and 3-positions.

The desired compounds were the 3-methyl- (157), the 2,3-dimethyl- (158), the 3,3-dimethyl- (159) and the 2,3,3-trimethyl-derivative (160) as these might be inhibitors of DHDPS. They might also provide information about the geometrical requirements for the elimination of water from 4-hydroxy-THDP (35) to form DHDP (27). The target compounds can be seen in **figure 75**.

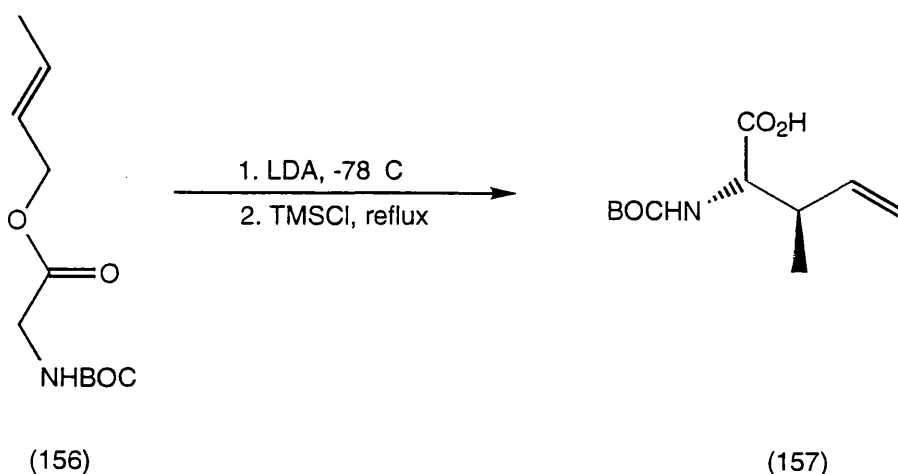


Figure 74: Synthesis of 3-methyl-2-(*t*-butoxycarbonylamino)pent-4-enoic acid

The initial starting materials for these compounds were the amino acids glycine and L-alanine. They were protected under the standard conditions for *N*-BOC protection. The two *N*-BOC amino acids (161) and (162) were isolated in quantitative yields as solids with melting points of 88-89 C (lit.,¹⁶⁴ 87-88 C) for *N*-BOC glycine (161) and 79-81 C for *N*-BOC alanine (162) (lit.,¹⁶⁵ 80-82 C).

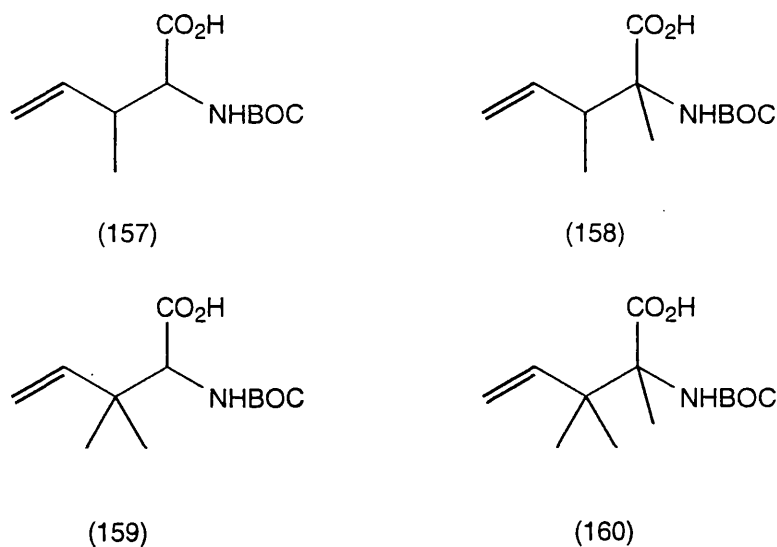
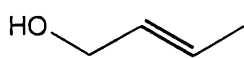
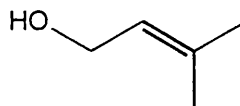


Figure 75: Target compounds from the Claisen rearrangement

The four esters required for the Claisen rearrangement were prepared by coupling these two *N*-protected amino acids to *trans*-crotyl alcohol (163) and 3-methyl-2-butene-1-ol (164). The couplings were achieved using DCC and 4-(dimethylamino)pyridine (DMAP) in ether.



(163)



(164)

(*E*)-2-Butenyl *N*-(*t*-butoxycarbonyl)amino acetate (156) was prepared and was identical to the material prepared by Bartlett and Barstow. The ^1H NMR spectrum of this compound is shown in **figure 76**. The methyl group of the ester was found at δ 1.7 and is clearly split into a doublet with a further small coupling to give a second doublet (J 6.3 Hz and 1.2 Hz). The two CH_2 groups were found at δ 3.9 for the ester CH_2 and 4.5 for the α - CH_2 of glycine. They are both doublets with 3J values of 5.7 Hz and 6.4 Hz respectively. The alkene protons are too highly coupled to enable J value assignment. The ^{13}C NMR spectrum showed no sign of the ester formed by the coupling of *N*-BOC glycine with the *cis*-crotyl alcohol present in the sample bought from Aldrich (~5%). The alkene carbons were found at δ 124.5 and 131.8, with the ester CH_2 group recorded at δ 42.3.

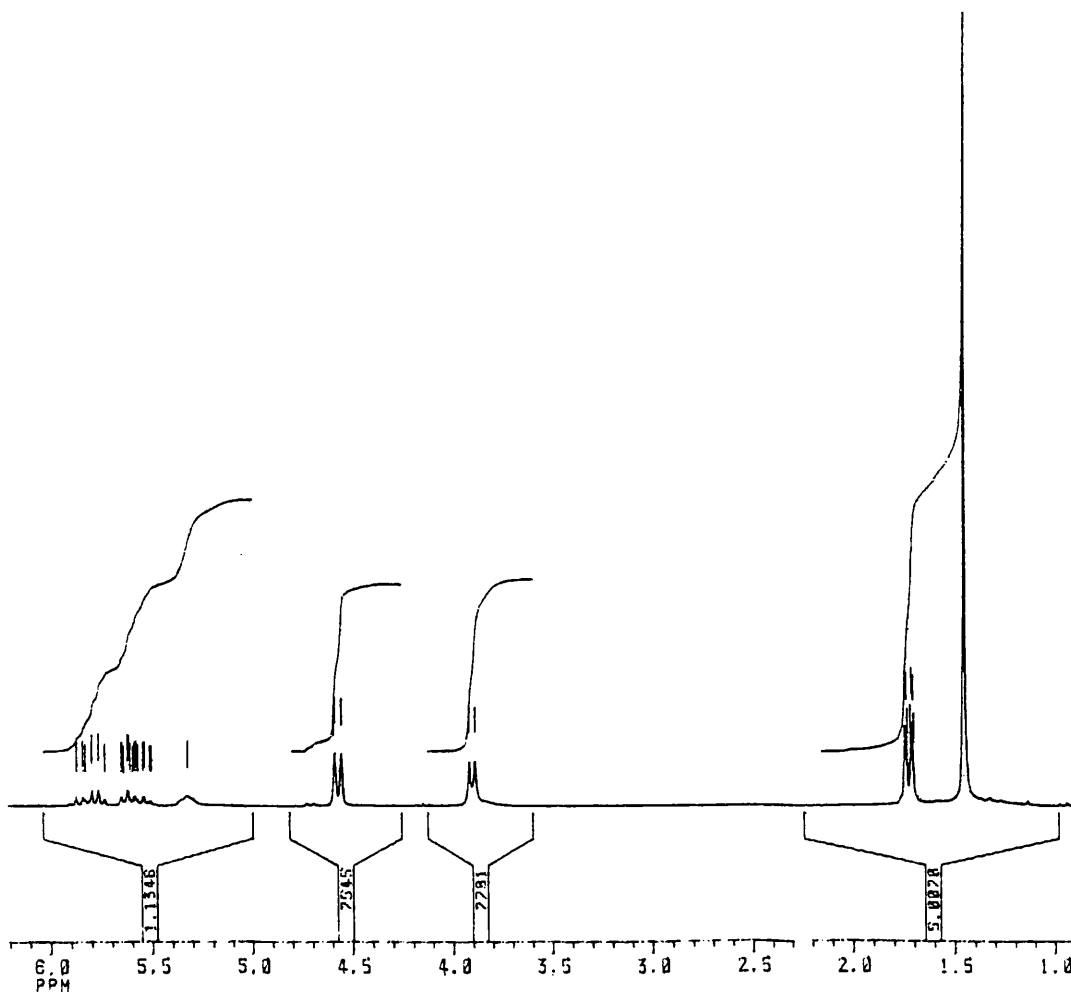
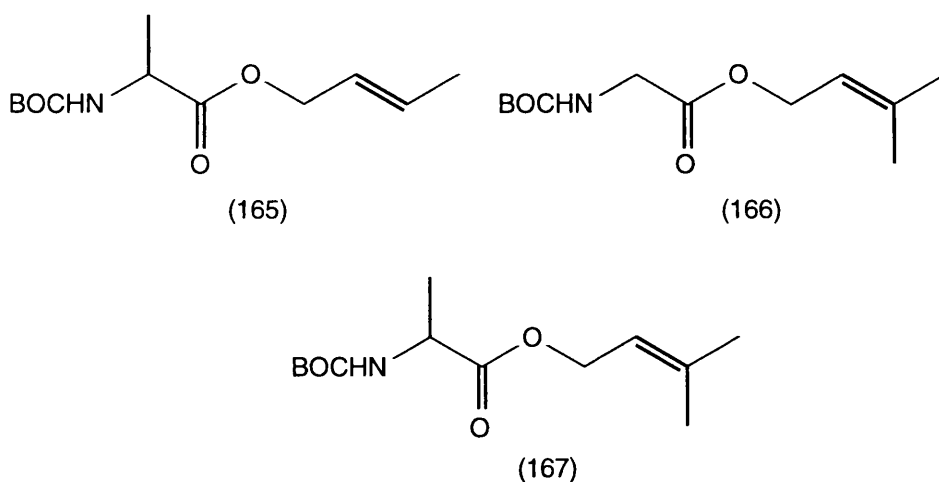


Figure 76: ^1H NMR spectrum of (*E*)-2-Butenyl *N*-(*t*-butoxycarbonyl)amino acetate

The other three esters were prepared under the same conditions and were isolated in the following yields: (*E*)-2-butenyl *N*-[(*t*-butoxycarbonyl-amino)propionate (165) 70%; (*E*)-2-(3-methyl)butenyl *N*-(*t*-butoxycarbonyl-amino)acetate (166) 70%; and (*E*)-2-(3-methyl)butenyl *N*-(*t*-butoxycarbonyl-amino)propionate (167) 62%.

All of the esters showed NMR spectra consistent with the structures assigned to them, and the spectra were similar to those recorded for (156). The methyl groups of the esters were all found between δ 1.2 and 1.5 in the ^1H NMR spectra. Mass spectra gave ions which lacked the alkene group of the esters. For (156) a signal at m/z 174 was recorded and for compounds (165)-(167) the signals were found at m/z 188, 188 and 201 respectively.

The conditions chosen for the Claisen rearrangement were to generate the enolate of the esters (156), (165), (166) and (167) using LDA (2.1 equivalents to ensure complete removal of the α -proton). This enolate was then treated with trimethylsilyl chloride (TMSCl) to trap the enolate as the corresponding silyl enol ether. Allowing the mixture to warm to room temperature and then heating at reflux induced the Claisen rearrangement to give 3-methyl-2-(*t*-butoxycarbonylamino)pent-4-enoic acid (157). The reported diastereoselectivity¹⁶⁴ for this rearrangement was 9 to 1 and a similar value was recorded in this work. The minor diastereoisomer was difficult to identify by ^{13}C NMR spectroscopy of the crude reaction products.



The Claisen ester-enolate rearrangement shown in **figure 77**, takes place through a six-membered transition state. The reaction is believed to proceed through the more stable chair-like transition state rather than the boat-like transition state.¹⁶⁶ This helps to define the regiochemistry of the various groups on the resulting product, and the most stable chair conformation will give rise to

the products. This means that the groups are arranged around the *pseudo*-chair in the positions that generate the least amount of steric strain. That is the larger groups will tend to adopt *pseudo*-equatorial positions.

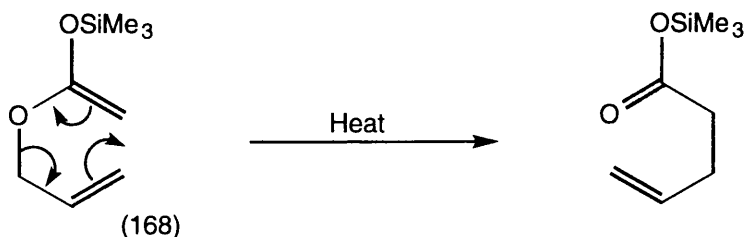


Figure 77: Claisen ester-enolate rearrangement

The rearrangement of the esters proceeds through a di-anion with the enolate adopting *E*-geometry (169), see **figure 78**. The lithium co-ordinates the nitrogen and the oxygen of the carbonyl helping to stabilise the geometry (170). TMSCl then traps the enolate in the conformation chelated by the lithium cation. The rise in temperature provides the energy required for the Claisen rearrangement to take place. The diagrammatical representation of the transition state geometry (171) is shown in **figure 79**. The methyl and the *N*-BOC groups adopt *pseudo*-equatorial positions relieving a great deal of steric strain. The TMS ether would also be expected to adopt a *pseudo*-equatorial position in order to minimise strain in the transition state.

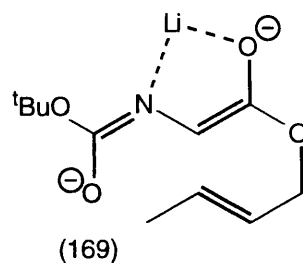
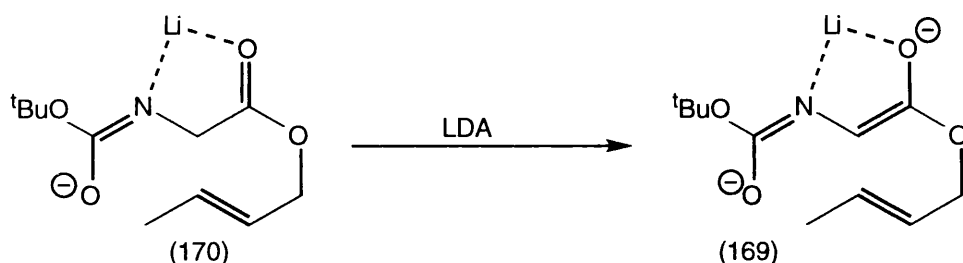


Figure 78: The geometry of the enolate adopted for the rearrangement of (156)

This arrangement of groups in the transition state would give rise to the *anti*-arrangement of the *N*-BOC and methyl groups found in the main product (172) of reaction.

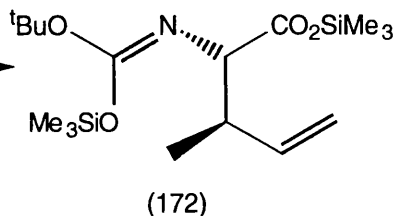
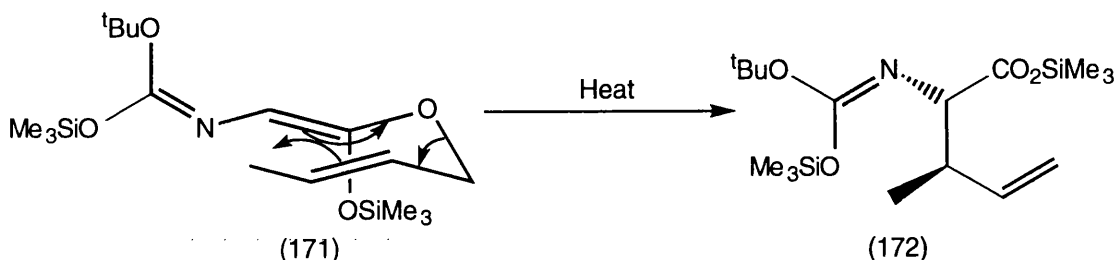


Figure 79: Diagrammatical representation of the transition state

3-Methyl-2-(*t*-butoxycarbonylamino)pent-4-enoic acid (157) was isolated as a solid from the reaction mixture in 68% yield. The ^1H and ^{13}C NMR spectra were recorded and showed a doublet for the methyl group at δ 1.1 with a coupling constant of 7 Hz. The C-2H and C-3H were found at δ 4.2-4.4 and 2.7. A long term ^{13}C NMR spectrum (32,000 scans for the broad band) showed the signals for the minor diastereoisomer, see **figure 80**. The most noticeable signal for the other diastereoisomer was the signal for C-2 at δ 58.9 (δ 57.3 for the major diastereoisomer).

2,3-Dimethyl-*N*-(*t*-butoxycarbonylamino)pent-4-enoic acid (158) was produced by the Claisen rearrangement in 80% yield from (165) and 3,3-dimethyl-*N*-(*t*-butoxycarbonylamino)pent-4-enoic acid (159) was prepared in 79% yield from (166). The rearrangement of (167) did not produce consistent results, with at maximum 10% yield of the rearranged product (160) produced. Upon work-up of the organic layer only a small percentage of the starting material could be recovered, not fully accounting for the mass balance. The transition state must therefore be too crowded with the three methyl groups present to allow the efficient adoption of the correct geometry for rearrangement.

The conversion of these three compounds into the corresponding aldehydes was carried out for the synthesis of ASA (23), see **figure 81**. The compounds were protected at the acid group using *p*-methoxybenzyl chloride in basic solution to give the *p*-methoxybenzyl esters (173), (174) and (175) in yields of 85%, 86% and 84% respectively. The PMB esters all showed the characteristic AA'BB' system for the benzyl ester in the aromatic region of the ^1H NMR spectra. The diprotected esters were now subjected to ozonolysis in dichloromethane to give the aldehydes (176), (177) and (178). The aldehydes were isolated as pale yellow oils with yields of 80%, 90% and 93% respectively.

The ^1H NMR spectra of the aldehydes showed the aldehyde proton for compounds (176), (177) and (178) at δ 9.6, 9.3 and 9.5, respectively. The ^{13}C NMR spectrum for (178) is shown in **figure 82**. The spectrum showed clearly the two methyl groups on C-3 at δ 0.90 and 0.98. The C-2 proton was found as a doublet at δ 4.5, with a *J* value of 9.5 Hz. The proton was coupled to the NH, found at δ 5.2, of the amino acid; this also appears as a doublet with a *J* value of 9.5 Hz. The ^{13}C NMR spectrum showed the methyl groups at δ 17.5 and 18.8 with the C-2 and C-3 carbons of the amino acid appearing at δ 57.2 and 49.9 respectively. The aldehyde signal was recorded at δ 201.9.

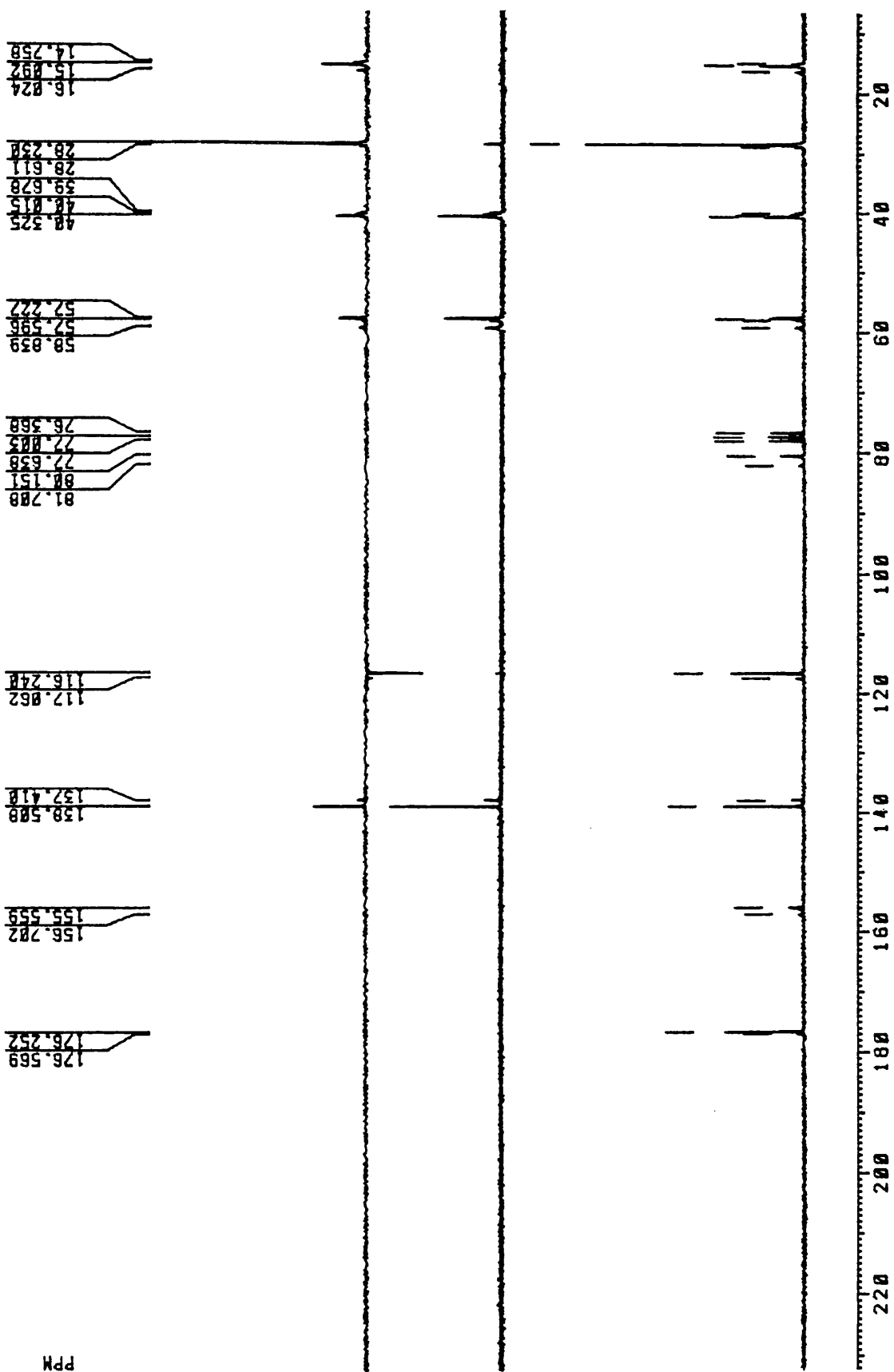


Figure 80: ^{13}C NMR spectrum for 3-methyl-2-(*t*-butoxycarbonylamino)pent-4-enoic acid (157)

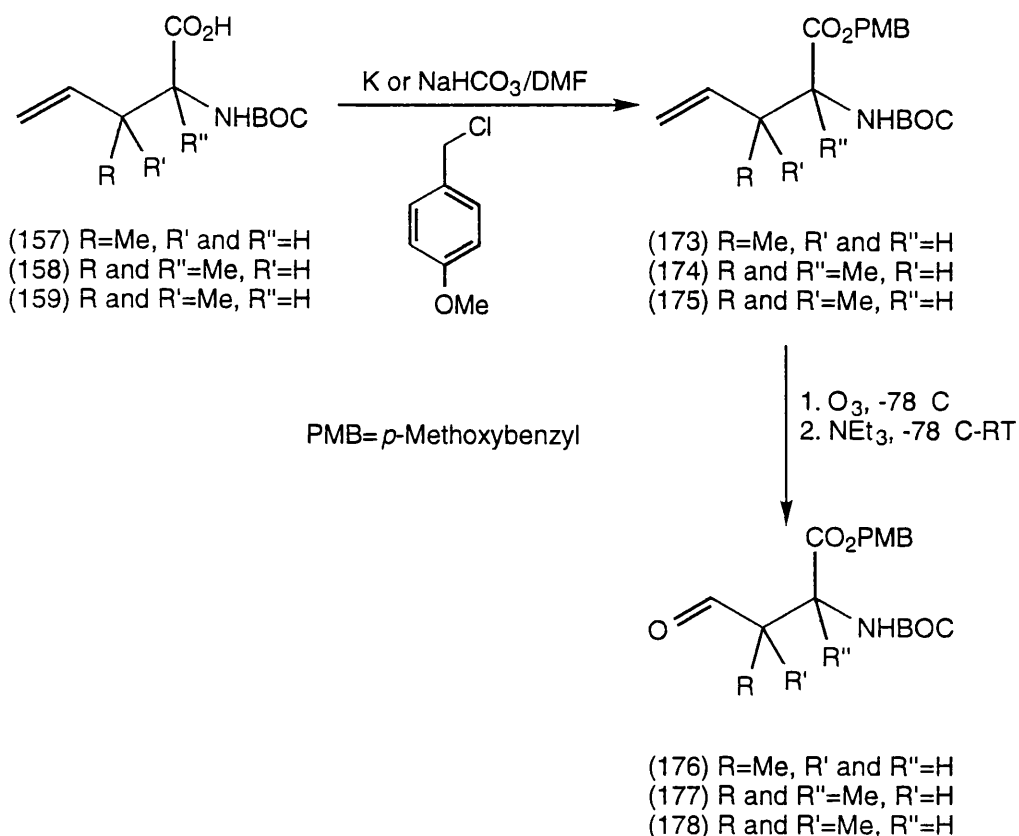


Figure 81: Preparation of the aldehydes (176), (177) and (178)

The three compounds were deprotected using TFA to produce (179), (180) and (181) as pale solids. Like the TFA salt of ASA (23) these compounds were isolated as hydrates. The ¹H NMR spectra showed a signal about δ 5.0 for all of these compounds. For compound (179) the signal was a doublet, for (180) the signal was also a doublet, but for compound (181) the signal was a singlet. The testing of these compounds with DHDPS will be discussed in chapter seven.

3.9 Preparation of 2-amino-4-epoxypentanoate

The epoxide of diprotected allylglycine (182) was prepared as an intermediate in the synthesis of 2-amino-4-epoxypentanoate (183). This compound was a desirable target as it might prove to be a good inhibitor of DHDPS. The nucleophilic species, on DHDPS, near the active site might be close enough to react with the epoxide and therefore trap the compound at or near the active site.

The epoxide was prepared by reacting diprotected allylglycine (125) with *m*-chloroperbenzoic acid (MCPBA) in dichloromethane at 0 C, see **figure 83**.

The epoxide was isolated after purification using silica gel chromatography in 90% yield. The ^1H NMR spectrum showed the epoxide CH at δ 3.0 and the CH_2 appeared at δ 2.5 and 2.7. The signals for the α -CH and the C-3 H_2 were found at δ 4.4 and 1.9 respectively. The ^{13}C NMR spectrum showed no signals corresponding to the alkene carbons of the starting diprotected allylglycine (125) but did however have signals attributable to the CH and CH_2 of the epoxide at δ 48.8 and 46.2, respectively. Deprotection using TFA produced a pale, very hygroscopic solid (183) in 65% yield. The NMR spectra showed signals attributable to the epoxide, indicating that the epoxide did not open under the acidic conditions.

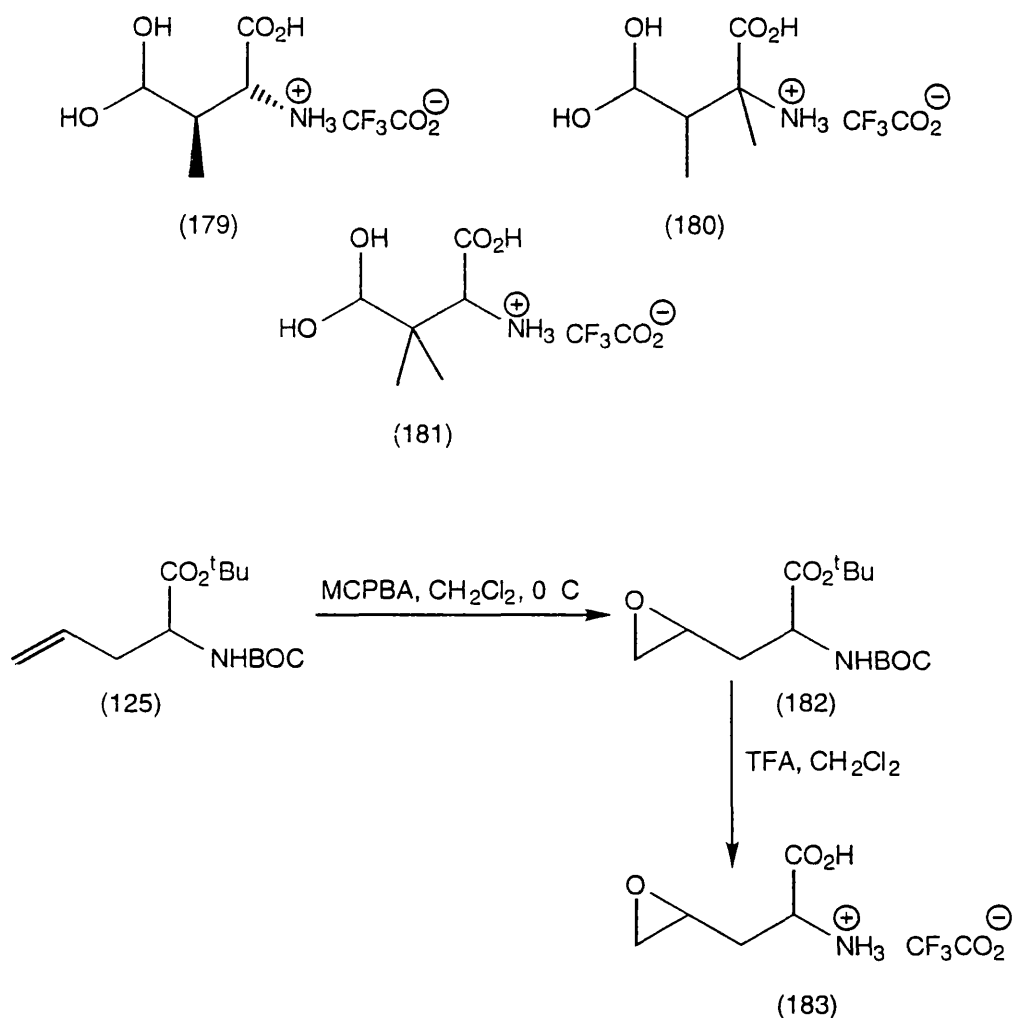


Figure 83: Preparation of 2-amino-4-epoxy-pentanoate

3.10 Attempted preparation of α -difluoroallylglycine

The synthesis of the α -difluoro substituted ASA was desired to test the effects of fluorine substitution in the molecule. The methodology developed for the preparation of α -substituted allylglycines was used to try to alkylate the α -position of (125) with chlorodifluoromethane (CDFM) to produce (184).^{167,168}

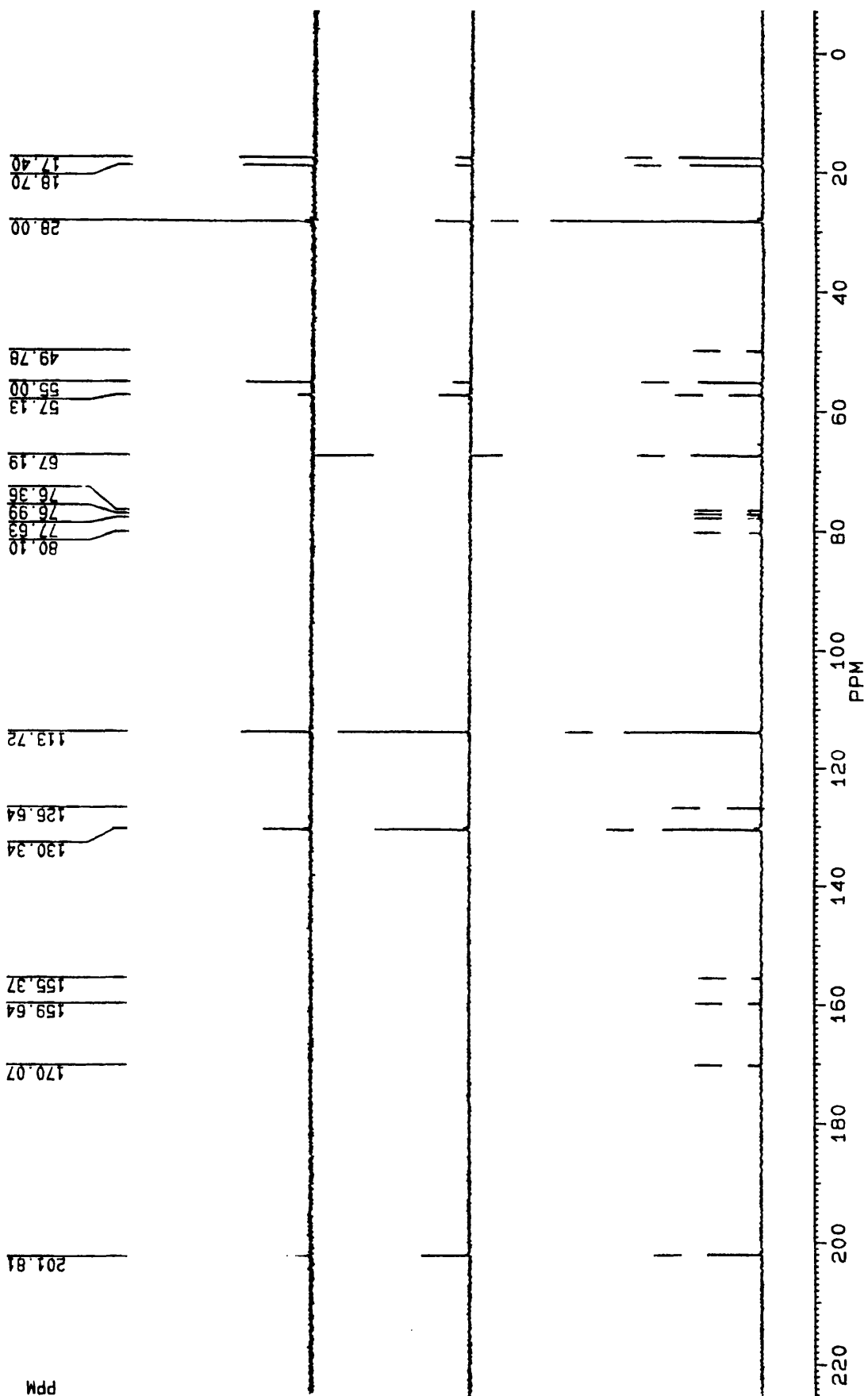
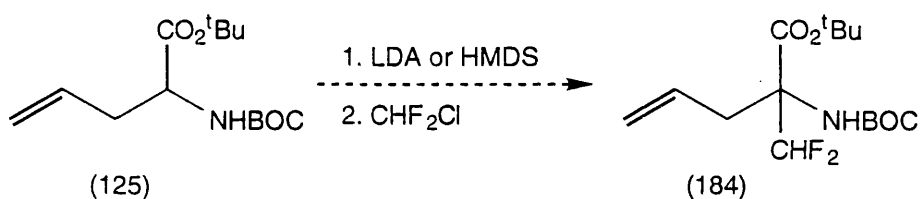


Figure 82: ^{13}C NMR spectrum of (178)

The methodology calls for the generation of the α -anion using LDA and then addition of the alkylating agent. This procedure was carried out and as soon as the gaseous CDFM was bubbled through the solution of the anion of (125) a colour change from pale yellow to dark black was seen. After work-up the ^1H NMR spectrum showed no sign of the starting material (125) nor of the expected product (184). All that was isolated was an unidentifiable mixture of hydrocarbons. This instantaneous colour change was put down to the formation of the extremely reactive difluorocarbene from CDFM and the anion generated from (125) and LDA; this is not unknown for CDFM under basic conditions.¹⁶⁸



The use of the base hexamethyldisilazane (HMDS) for the deprotonation was reported to reduce the formation of difluorocarbene.¹⁶⁹ The product from this reaction was found to be a mixture of starting material and unidentifiable organic components.

It was not a sound strategy to prepare the α -difluoromethyl compound by this method as the molecule contains too many sites for carbenes to attack and then to react further. It would be advantageous to incorporate the difluoromethyl group before the allyl side chain as this would make the molecule less reactive towards carbenes.

3.11 Conclusions and Future work

A number of alkylated ASA derivatives were prepared in this chapter along with some other analogues and derivatives. These were prepared in reasonable yields and were deprotected using TFA to produce the trifluoroacetate salts of the amino acids.

From the biochemical testing, presented in chapter seven, it was found that the *N*-formyl ASA (146) was not an inhibitor of DHDP synthase. The same result was obtained for succinate semialdehyde (154) and 2-amino-4-epoxypentanoate (183). The α - and β -alkylated ASA derivatives were also found to be very poor inhibitors of DHDP synthase.

The α - and β -alkylated ASA derivatives showed more promise as substrates for DHDP synthase. They appear to be turned over by the enzyme at an appreciable rate. The β -alkylated ASA derivatives would readily form 3-methyldipicolinic acid, but the product from the enzymic reaction on the α -methyl ASA derivative has not yet been identified. Further investigation of these two interesting biotransformations will be required to isolate and characterise the products of the enzymic reactions.

If these compounds are indeed being turned over by DHDP synthase, it would be the first biotransformation of analogues found for this enzyme. This presents a new line of research. A number of ASA analogues will be required to test the range of biotransformations possible. These will presumably involve halogenated ASA analogues and various other alkylated analogues of ASA.

Chapter Four: Synthesis of Isoxazolines as Potential Inhibitors of DHDP Synthase

4.1 Heterocyclic compounds as inhibitors of DHDP synthase

Many heterocyclic compounds have been prepared as inhibitors of DHDP synthase and they exhibit varying degrees of inhibition. Some of the best inhibitors are those shown in chapter two, namely the pyridine analogues of L-DHDP (27). Some of the most potent inhibitors produced to date within our group at Glasgow were prepared by Dr. D. Tudor. These were 1,3-thiazoles (184), prepared by the cyclisation of L-cysteine and ethyl oxalyl chloride (185) and also by cyclisation of bromopyruvic acid with ethyl thioxamate (186), see figure 84.

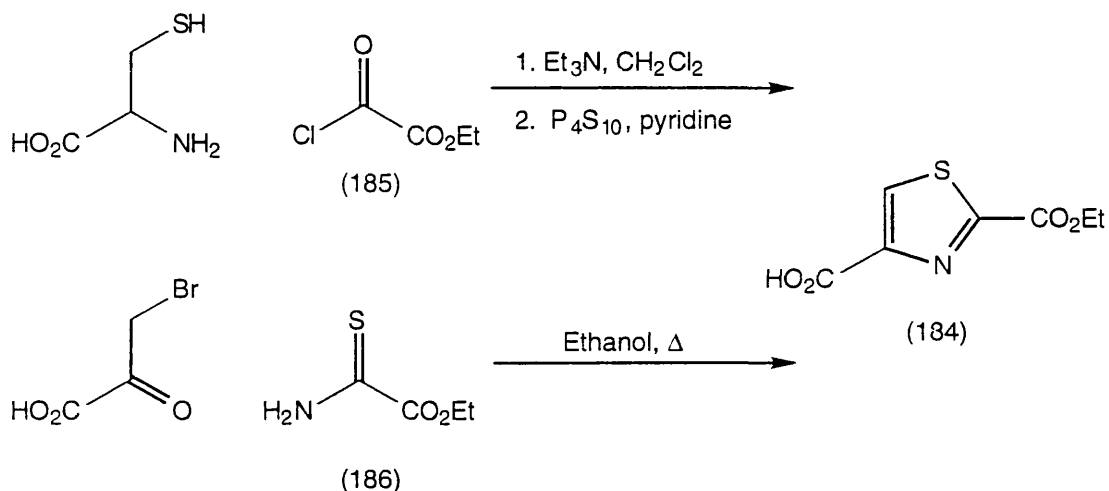


Figure 84 synthesis of 1,3-thiazoles

The 1,3-thiazoles (184) showed good inhibition as diesters. The methyl/ethyl ester and the diethyl ester were found to give approximately 21 and 15% inhibition at 0.1 mM respectively.

Following the promising results obtained from the five membered ring system present in the 1,3-thiazoles, it was reasoned that other five membered heterocycles might also be inhibitors. Therefore a number of isoxazolines were prepared to test against DHDP synthase.

Figure 85 shows the relationships that both ring systems (184) and (187) have to L-THDP (27) the product of DHDP synthase. The synthesis of isoxazolines is straightforward and allows the easy preparation of many substituents on the ring system.

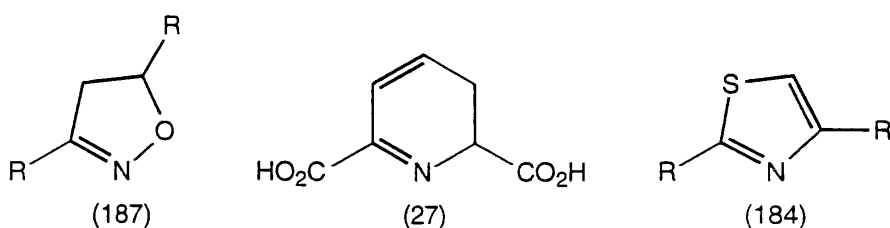


Figure 85: Relationship of the isoxazoline and 1,3-thiazine ring system to L-DHDP

4.2 Synthesis of isoxazolines

Isoxazolines are synthesised by means of a 1,3-dipolar cycloaddition with a dipolarophile. This reaction is one example of the many types of pericyclic reaction known to exist. These reactions involve the cyclic movement of electrons from π bonds to form new σ bonds. Pericyclic reactions are a very powerful tool for the preparation of a large number of organic compounds. **Figure 86** shows some of the many pericyclic reactions known.

As indicated in **figure 86** the 1,3-dipolar cycloaddition is an example of a $[4\pi+2\pi]$ cycloaddition with 4π electrons shared between three atoms. The reaction is generally referred to as dipolar because the three atom component cannot be represented by electron paired resonance structures without invoking charges, see **figure 87**.



Figure 87: Resonance structures for the 1,3-dipole of a nitrile oxide

Isoxazolines are prepared by the 1,3-dipolar cycloaddition of a nitrile oxide (188), prepared by one of two methods (see section 4.4), with an alkene or alkyne, see **figure 88**. The 1,3-dipole of the nitrile oxide is known to react faster with electron rich or poor alkenes compared with alkyl-substituted alkenes.

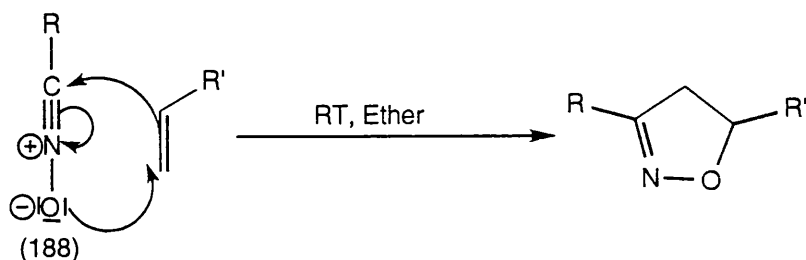
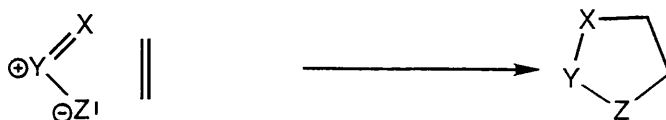


Figure 88: 1,3-Dipolar cycloaddition to form a 2-isoxazoline

Cycloadditions

[4 π -2 π]



[2 π -2 π]



Cheletropic Reactions



Sigmatropic Reactions

[1,5] sigmatropic rearrangement



[3,3] sigmatropic rearrangement



Ene reaction

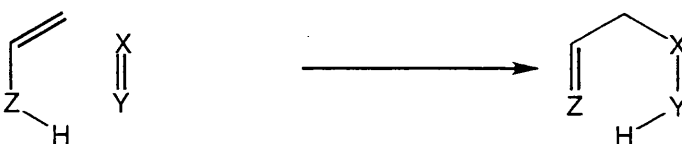


Figure 86: Some Pericyclic reactions

4.3 Mechanism of the 1,3-dipolar cycloaddition

Dipolar cycloadditions involving nitrile oxides are believed to proceed through an unsymmetrical transition state in which the formation of one σ bond is more advanced than the other.¹⁷⁰ The reaction proceeds through a transition state in which the 4 π electron system interacts with the 2 π electron system. The

approach geometry gives rise to a two plane system as seen in **figure 89**. This process is a thermally activated process and is allowed by the Woodward-Hoffmann rules.¹⁷¹ The rates of the reactions are affected only slightly by the changing polarity of the solvent indicating a transition state no more polar than the starting materials.

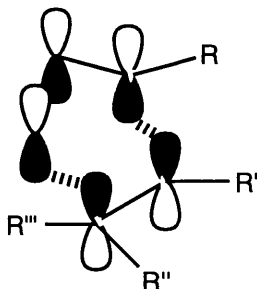


Figure 89: Transition state geometry of a 1,3-dipolar cycloaddition

Frontier orbital theory provides a great deal of insight into the reactivities and selectivities of pericyclic reactions including the 1,3-dipolar cycloaddition.¹⁷² The theory states that the reaction will proceed through a transition state as shown in **figure 89** and is favoured if orbitals of the same sign overlap. This interaction is usually between a filled π orbital of one reactant and an empty π^* orbital of the other. The interaction of these orbitals is stronger the closer they are in energy to each other. The orbitals best able to make this overlap are the HOMO (highest occupied molecular orbital) and LUMO (lowest unoccupied molecular orbital) of the dipole and dipolarophile. The relative energies of these frontier orbitals vary depending on the substitution of the reacting species. Reactions are therefore favoured if one species is strongly “nucleophilic” and the other species is strongly “electrophilic”. There are three cases of orbital overlap that can be envisioned depending on the substituents of the reacting species, see **figure 90**.

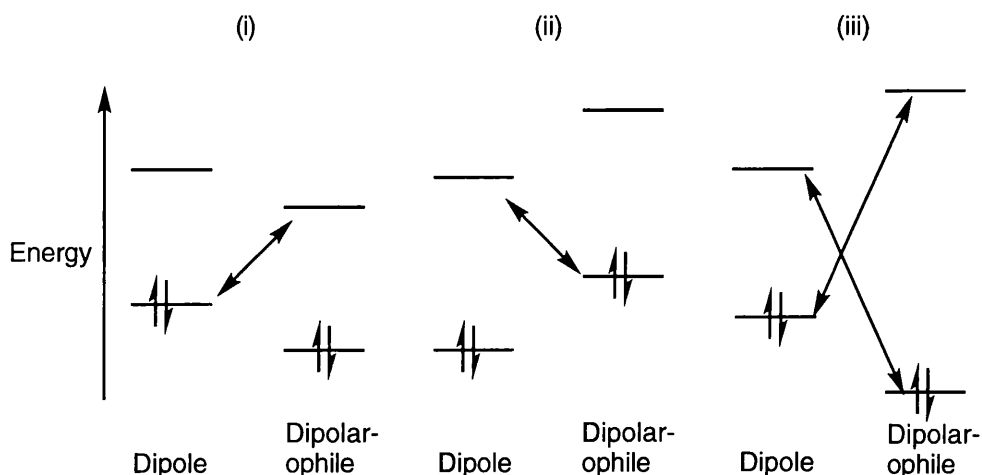


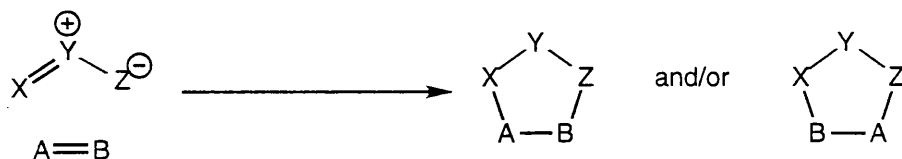
Figure 90: Dominant orbital overlaps for cycloadditions

The first case arises when the dipole HOMO and dipolarophile LUMO are closest in energy and they provide the best overlap. These are then the pair of orbitals which will dominate in the reaction. This situation arises when nitrile oxides react with alkene species with conjugative electron withdrawing groups. Case (ii) arises when the dipole reacts with electron rich dipolarophiles such as enol ethers and enamines. The HOMO of the dipolarophile is raised in energy by the electron donating substituent and the energy gap to the LUMO of the dipole is then the smallest in energy. For nitrile oxides case (iii) arises when they react with unsubstituted alkene species such as ethylene where neither orbital interaction dominates. This slows the reaction down and leads to low yields as the unstable nitrile oxide prefers to react with itself rather than react with the alkene.

Selectivity of 1,3-dipolar cycloadditions

Like all cycloaddition reactions the possibility of regioisomeric products is present as is the possibility of generating stereoisomeric products, see **figure 91**. However most 1,3-dipolar cycloadditions show considerable selectivity in that they give mainly or exclusively one product. Frontier orbital theory again provides an explanation for this selectivity. The strongest interactions are between orbitals of the same sign and so this helps to define the reacting orbitals. The orbital coefficients are then aligned so that the largest coefficients interact to give the product. This again is the most favourable interaction and is thus the driving force for the selectivity observed in the reaction products. A diagrammatic representation of this principle is shown in **figure 92** for the reaction of diazomethane with methyl methacrylate.

Regioselectivity



Setereoselectivity

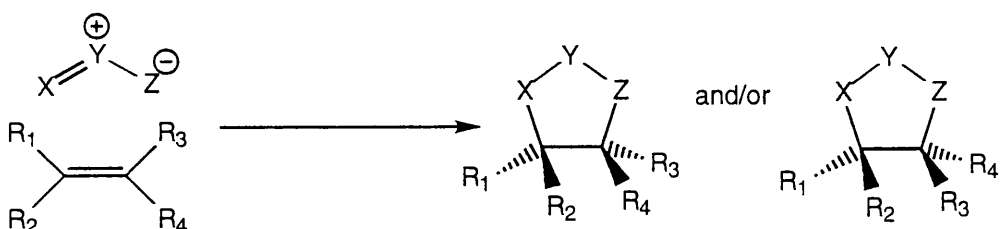


Figure 91: Possibilities for isomer formation in 1,3-dipolar cycloadditions

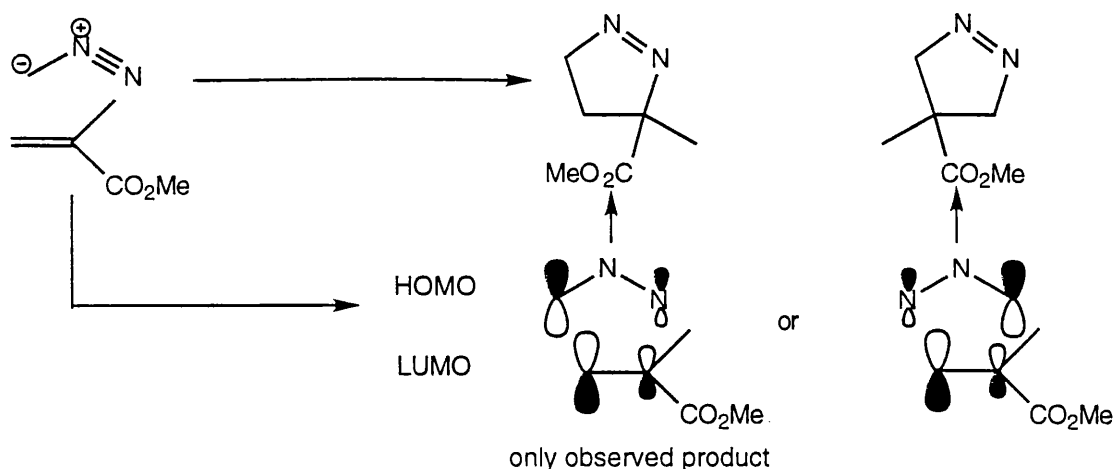


Figure 92: Regioselectivity in 1,3-dipolar cycloadditions

Stereoselectivity of the dipolar cycloaddition is observed with products isolated having only the stereochemistry of the starting materials. This is a consequence of the concerted nature of the reaction mechanism and is also proof that there can be no di-radical or anionic intermediate as this would allow for stereochemical scrambling. Mono-substituted alkenes will give isoxazolines with the substituent in the 5-position on the ring. This is a consequence of the frontier orbitals having coefficients as in **figure 92**.

4.4 Synthesis of nitrile oxides

Nitrile oxides as mentioned above are transient species that polymerise if no alkene is present with which to react. They are derived by one of two main methods. The first is the oxidation of aldoximes and the second involves the dehydration of nitro compounds. The first nitrile oxide produced was benzonitrile oxide (189) and was obtained in two stages by Werner and Buss.¹⁷³ They treated benzaldoxime (190) with chlorine gas at -20 to -40 °C to obtain (191). The product they obtained was treated with aqueous sodium bicarbonate to generate the nitrile oxide (189) by a dehydrochlorination procedure, see **Figure 93**.

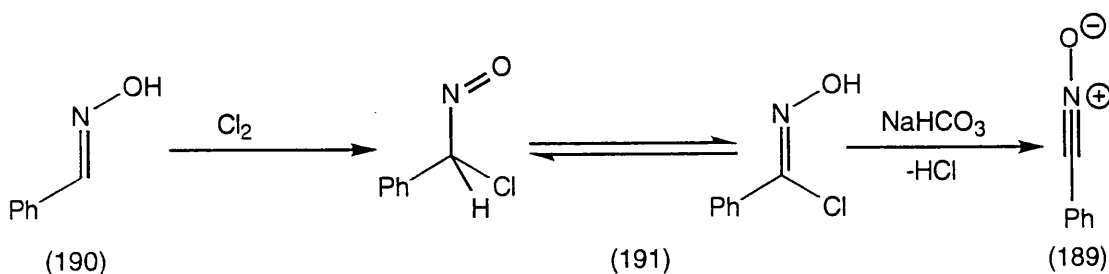


Figure 93: Preparation of benzonitrile oxide by Werner and Buss

The reaction proceeds via a transient nitroso compound as indicated by the blue colour of the reaction.¹⁷⁴ The best bases to use were sodium bicarbonate or sodium hydroxide although triethylamine was used in more recent preparations.¹⁷⁵⁻¹⁷⁷ The benzohydroximoyl chloride formed is solely the *Z*-form.¹⁷⁷ The *E*-form was prepared by photo-isomerisation of the acetate and subsequent hydrolysis.¹⁷⁹ The *E*-form was found to undergo the dehydrochlorination procedure 6×10^7 times slower than the *Z*-form. The main disadvantage of this procedure is the chlorination step. Chlorine is incompatible with a number of organic aldoximes including many aromatic species. Many procedures are now available for mild, selective chlorination using other popular chlorinating agents, including nitrosyl chloride¹⁸⁰ and *N*-chlorosuccinimide in chloroform.¹⁸¹

The second significant method for the preparation of nitrile oxides was devised by Mukaiyama and Hoshino.¹⁸² This method involves the dehydration of nitro compounds using phenyl isocyanate. This method is not suitable for the isolation of a progenitor of the nitrile oxide but it does permit the insitu preparation and trapping of the nitrile oxide. Triethylamine was required in catalytic amounts for the initial proton abstraction, see **figure 94**. The reaction has recently been applied to an increasing number of primary nitro compounds and works well for most cases.¹⁸² It fails however with nitromethane, where after proton abstraction by triethylamine the phenyl isocyanate attacks the methyl carbon to generate an α -nitroacetanilide.

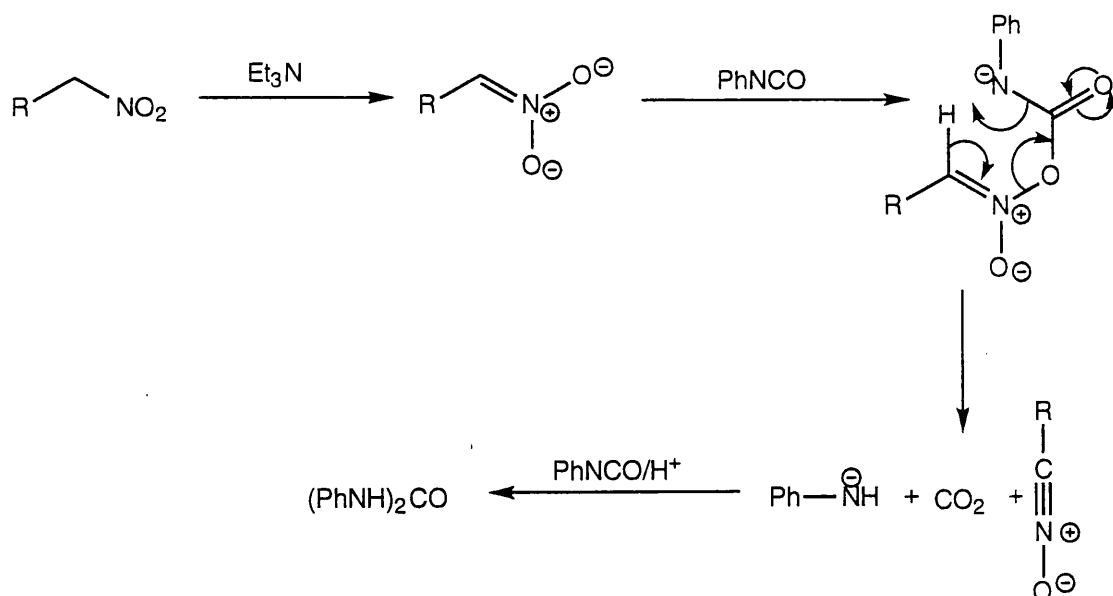


Figure 94: Formation of a nitrile oxide from a primary nitro compound using phenyl isocyanate

4.5 Synthesis of isoxazolines

Approximately ten isoxazolines were prepared by the 1,3-dipolar cycloaddition of various alkenes onto ethyl chlorooximidoacetate, the progenitor of the 1,3-dipole used in all of the reactions detailed below. Ethyl chlorooximidoacetate (192) was first reported by Skinner¹⁸³ in 1923. An improved preparation was reported in 1983 by Kozikowski and Adamczyk.¹⁸⁴

The procedure of Skinner describes the conversion of glycine ethyl ester hydrochloride (193) into ethyl chlorooximidoacetate (192). The reaction was carried out at room temperature in water. Addition of hydrochloric acid, slowly by dropwise addition and then followed by aqueous sodium nitrite was all that was required to achieve the transformation. The solution was stirred for two hours at 0 °C before work-up, and crystallisation afforded ethyl chlorooximidoacetate (192) in a 50% overall yield from the cheap starting material glycine ethyl ester.

The solid has a melting point of 79-80 °C, which compares well to the literature value of 80 °C.¹⁸⁴ The ¹H and ¹³C NMR spectra showed the formation of the oxime and the removal of the α -protons of glycine ethyl ester (193). The signal at δ 3.9 was absent from the ¹H NMR spectrum of ethyl chlorooximidoacetate (192). The oxime proton appeared at δ 10.5. The only other signals were for the ethyl group of the ester at δ 1.4 and 4.4. The ¹³C NMR spectrum was more revealing with the ester carbonyl appearing at δ 158 and the oxime carbon-nitrogen double bond appearing at δ 133. Mass spectrometry confirmed the presence of ethyl chlorooximidoacetate (192), showing a molecular ion at m/z 151 and a peak corresponding to the loss of the oxime proton at m/z 150.

The proposed method for formation of ethyl chlorooximidoacetate (192) from glycine ethyl ester (193) is shown in **figure 95**. It involves the formation of an alkyl diazonium species (194) initially. This species is then transformed into the C-nitroso compound (195) which tautomerises to the oxime (196). Chlorination and loss of nitrogen then occur in an unspecified order.

Whether this is the procedure by which the transformation was achieved was not proven conclusively by Skinner. It does however, seem unlikely that the alkyl diazonium species would form as the first stage in this reaction. Alkyl diazonium species are unstable and the glycine nitrogen atom will be protonated almost fully under the reaction conditions. It may be more plausible to invoke the C-nitrosation and tautomerisation as the first stage as this would

be a more feasible reaction under the conditions. Nitrosation of carbons adjacent to electron withdrawing species is a well known reaction with nitrosyl chloride. Sodium nitrate and concentrated hydrochloric acid form nitrosyl chloride and nitrous acid as products of reaction. Nitrosyl chloride is a long lived and stable form of NO^+ , which can react with the enol form of glycine ethyl ester to produce the C-nitroso compound. It is likely that chlorination will occur with the oxime as these compounds are known to be easily chlorinated.¹⁸⁵ Nitrogen will probably be lost from a diazonium species eventually, probably as a late stage reaction.

There are many pathways by which the transformation of glycine ethyl ester into ethyl chlorooximidoacetate could be achieved. The fact that the reaction calls for slow addition of the acid to the ester implies that a reaction of the ester would be a likely first step. The amine will remain protonated almost fully throughout the reaction due to the low pH and it is difficult to imagine it acting as a nucleophile at any point during the mechanism. This differs from the aromatic case where as the amine group is delocalised and its pK_a is therefore higher, it can react with the nitronium species formed. It is clear that a number of questions remain regarding the formation of ethyl chlorooximidoacetate. Only further investigation of the mechanism may provide the answers.

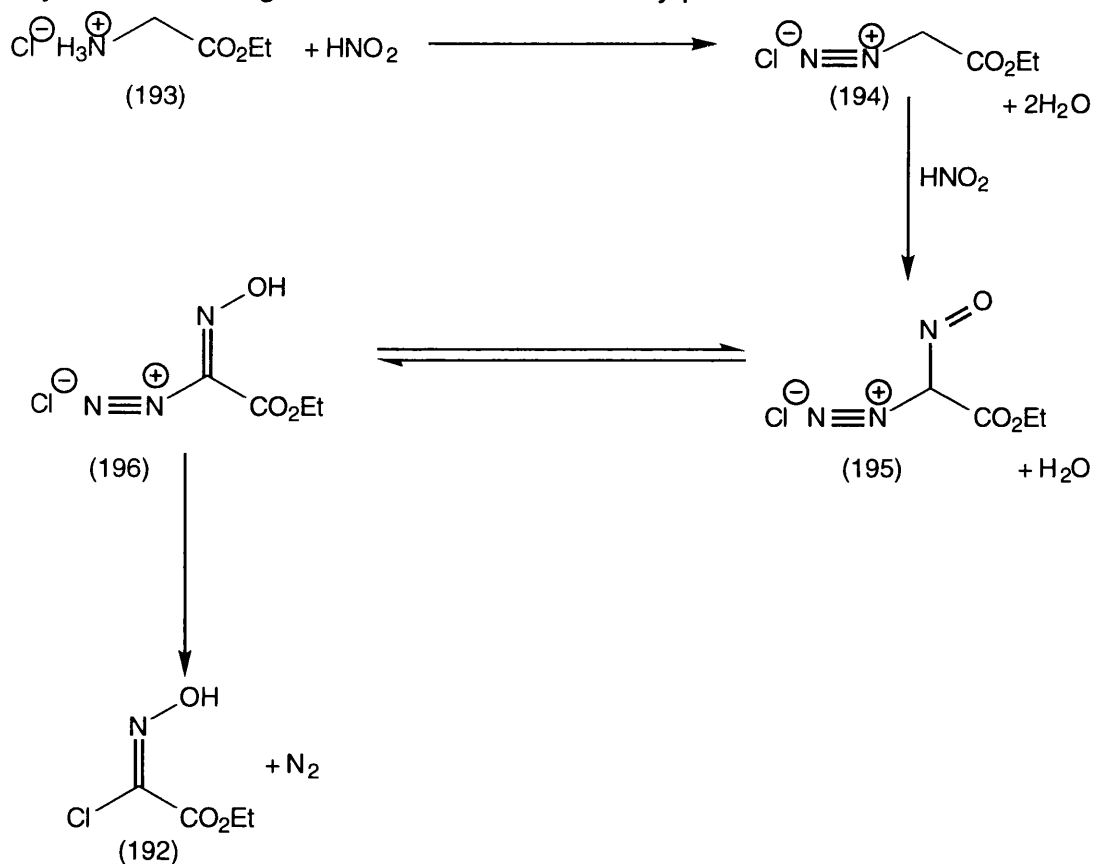


Figure 95: Proposed formation of ethyl chlorooximidoacetate from glycine ethyl ester¹⁸³

The first cycloaddition attempted utilised acrylonitrile as the alkene component. This is a cheap and reactive alkene and was chosen because it was assumed that the reactivity of the olefin would prevent any unwanted dimerisation of the nitrile oxide from taking place. All of the nitrile oxides based on the dehydrohalogenation of ethyl chlorooximidoacetate (192) were prepared under the same reaction conditions. The base used to generate the nitrile oxide was aqueous sodium carbonate, which was added slowly to a mixture of the alkene and ethyl chlorooximidoacetate (192) in ether. The reactions were considered as finished after about two hours, as any nitrile oxide that had not reacted with the alkene would have dimerised or polymerised by then. Work-up was extraction of the isoxazoline into ethyl acetate and purification by column chromatography if this was required.

Reaction of (192) with acrylonitrile under the conditions outlined above gave a clear oil in 90% yield. The product was 5-cyano-3-ethoxycarbonyl-2-isoxazoline (197), see **table 8**. The production of the 5-substituted isoxazoline as the sole product can be predicted on the basis of frontier orbital theory as outlined previously for the addition of diazomethane to methyl methacrylate. The orbital co-efficients for acrylonitrile are shown pictorially in **figure 96**.

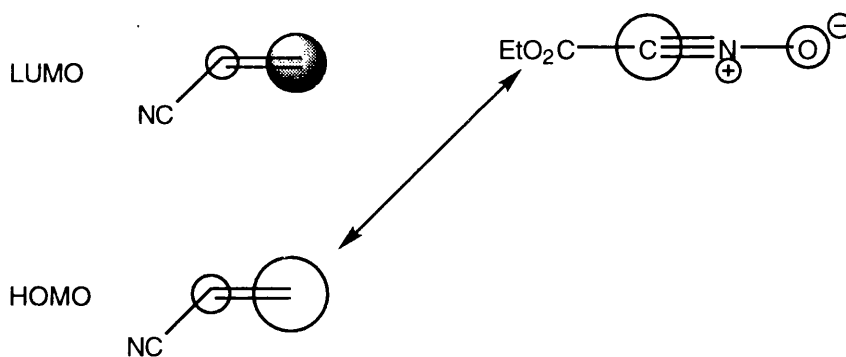


Figure 96: The HOMO and LUMO of acrylonitrile with pictorial representation of the orbital coefficients

The ^1H and ^{13}C NMR spectra support the production of a single regioisomer as no signals were visible for the 4-substituted isoxazoline ring system, but a small amount of dimerisation had taken place. The ^1H NMR spectrum had signals at δ 1.37 and 3.65 for the ethyl ester and an ABX system for the three remaining protons. The protons at the 4-position of the isoxazoline ring were found at δ 3.65 and those in the 5-position were at δ 5.50. The ^1H NMR spectrum of 5-cyano-3-ethoxycarbonyl-2-isoxazoline (197) can be seen in **figure 97**. The

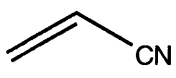
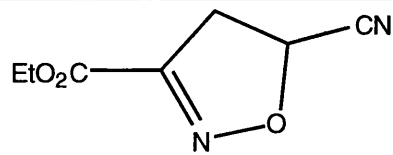
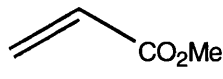
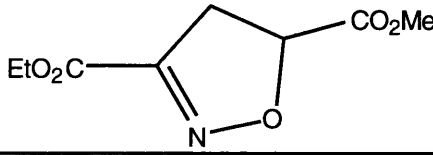
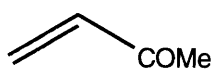
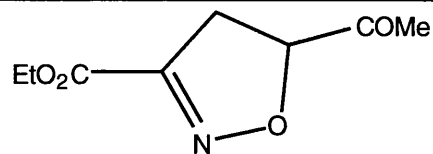
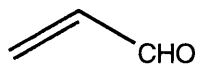
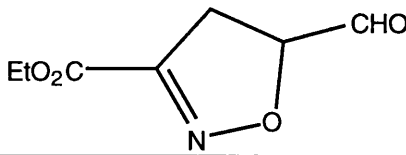
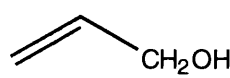
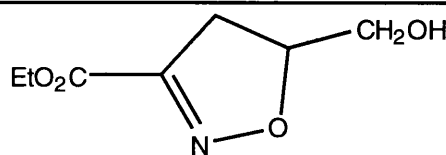
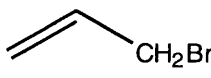
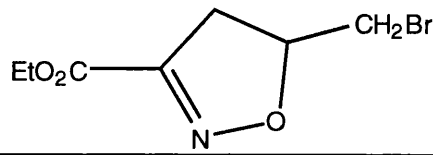
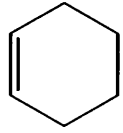
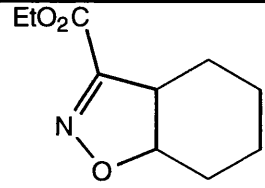

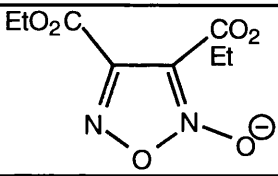
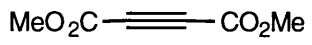
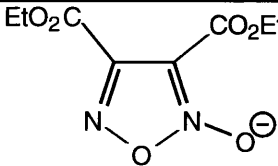
Desired Compound	Olefin component	Product of Reaction	Yield (%)
(197)			90
(198)			68
(199)			86
(200)			5
(201)			64
(202)			80
(203)			31
(204)			variable
(205)			variable

Table 5: Summary of isoxazolines prepared from simple alkenes

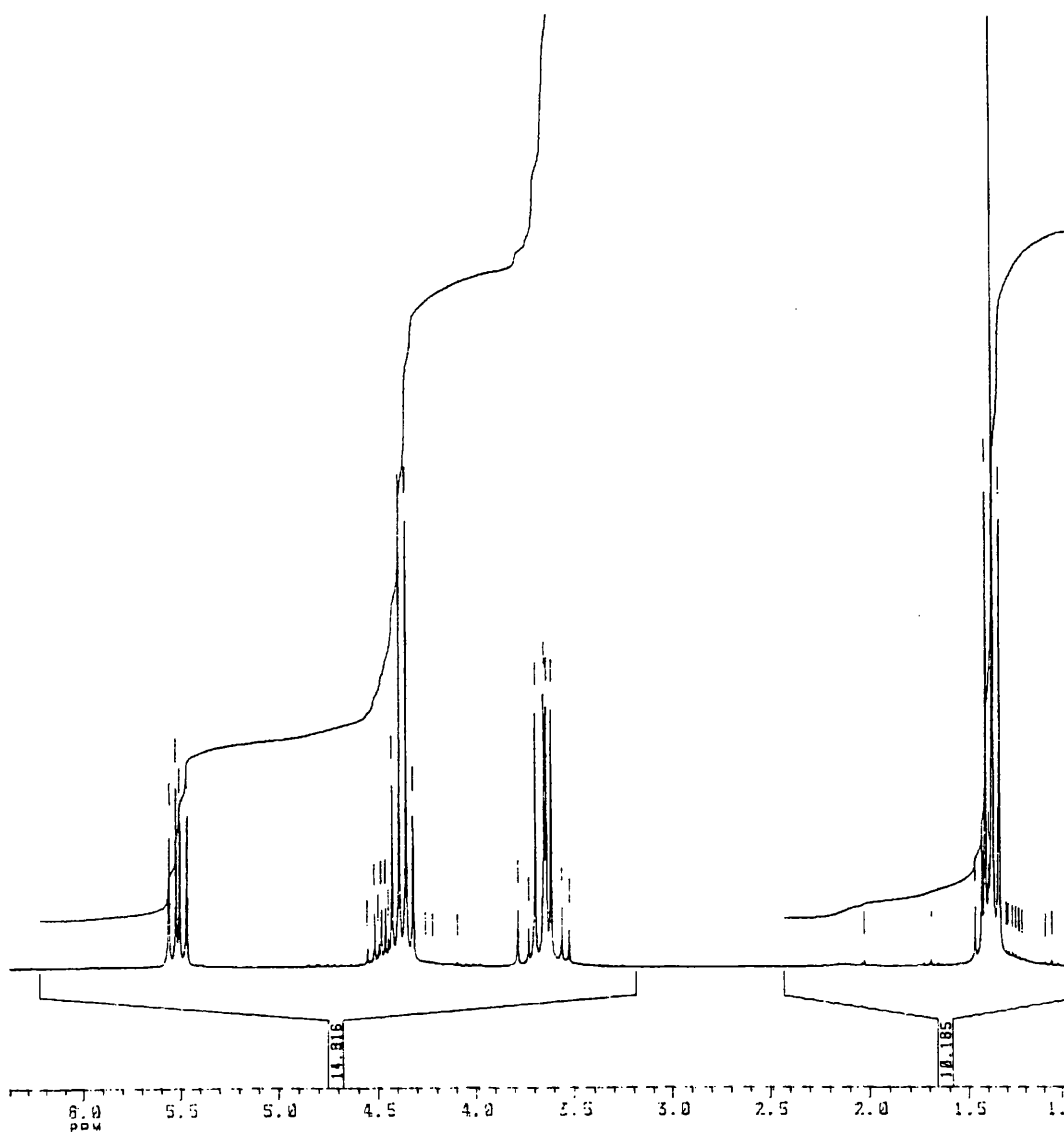


Figure 97: ^1H NMR spectrum of 5-cyano-3-ethoxycarbonyl-2-isoxazoline

ABX coupling system arises because the two protons on the 4-position are diastereotopic. These couple to the sole proton at the 5-position. ABX systems to their first order approximation should look like the set shown in **figure 98**.¹⁸⁶ This example is taken for a relatively large chemical shift separation of the AB protons. The X proton is split by both A and B protons and gives rise to a doublet of doublets, with lines of nearly equal intensity. The interpretation of this system is made more difficult by the fact that the coupling constants can no longer be reliably read from the spectrum. For the X component the separation of the two outer lines (1 and 4 in **figure 98**) is equal to J_{AX+BX} . The separation of the outer and inner lines (1 and 2) is now not strictly equal to J_{AX} or J_{BX} .

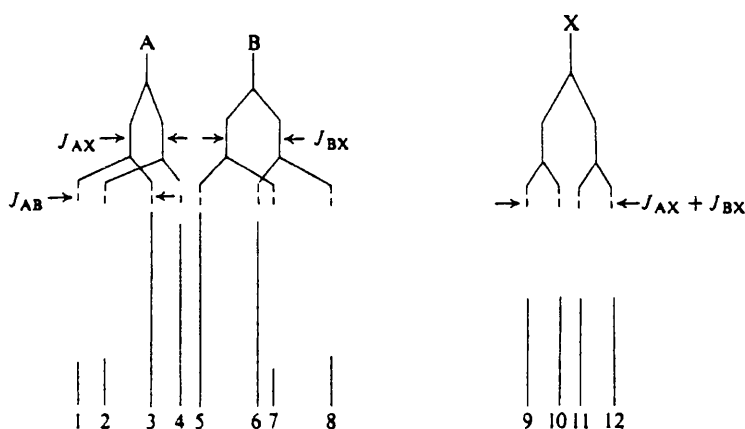


Figure 98: ABX system for well separated AB protons¹⁸⁶

The ^{13}C NMR spectrum again showed the peaks for the ethyl ester at δ 13.3 and 62.7. The AB CH_2 was found at δ 39.7 and the X was found at δ 68.3, an indication that the regiochemistry is as expected for the 1,3-dipolar cycloaddition. The opposite regiochemistry would produce a product where the 4-CH would be expected at δ 27.1 in the ^{13}C NMR spectrum. The nitrile was found at δ 116.3 and the carbonyl and C-N double bond were found at δ 158.8 and 151.7 respectively. Mass spectrometry showed a signal at an m/z of 168 which corresponds to the molecular ion. The isoxazole ring system, without any substituents was seen at m/z 69. The mass spectrum also showed the loss of the nitrile, the ethyl group from the ester and finally the carboxylate group at m/z of 142, 139 and 95. The nitrile and the C-N double bond appeared in the IR spectrum at 2245 and 1645 cm^{-1} , respectively.

The other isoxazolines produced can be seen in summary in **table 5**. These were made with varying yields and the amount of the nitrile oxide dimer formed during the reaction varied with the alkene component used.

Treatment of ethyl chlorooximidoacetate (192) with sodium carbonate in the presence of methyl acrylate gave a 68% yield of 5-methoxycarbonyl-3-ethoxycarbonyl-2-isoxazoline (198). The ^1H and ^{13}C NMR spectra again showed the production of a sole regioisomer. The mass balance is presumably made up by the nitrile oxide dimer which was removed with other impurities by silica gel chromatography.

Signals in the ^1H NMR spectrum corresponding to the ethyl ester were found at δ 1.4 and 4.3. The more diagnostic signals were those for the three ring protons.

These form what appeared to be a simple AX system with the CH₂ at δ 3.5, being split into a doublet of 3J 9.9 Hz by the CH proton. The CH at δ 5.24, was in turn split by the CH₂ into a triplet with a coupling constant of 3J 9.6 Hz. This system could however be a collapsed ABX system, that is one where the chemical shift difference between the A and B protons is not significant. The methyl ester was found at δ 3.81. The ¹³C NMR spectrum showed three quaternary carbons at δ 151.1, 159.6 and 169.3 which correspond to the C-N double bond, the ethyl ester and the methyl ester respectively. The ring carbons were found at δ 37.5 for C-4 and at δ 79.6 for C-5. The other peaks present were attributed to the ester groups. The mass spectrum of compound (199) again showed the molecular ion at *m/z* 201 with a similar pattern of breakdown to that recorded for compound (198). The loss of groups until the isoxazoline ring system was unsubstituted, was again the main method of fragmentation found for these compounds. IR spectroscopy showed the C-N double bond at 1627 cm⁻¹.

Preparation of 5-hydroxymethyl-3-ethoxycarbonyl-2-isoxazoline (200) required treatment of ethyl chlorooximidoacetate (192) with allyl alcohol, in the presence of sodium carbonate. The compound was isolated as an oil in 64% yield. NMR spectroscopy confirmed the production of this compound and again only the 5-substituted regioisomer was formed. The ¹H NMR spectrum showed the ABX system for the ring protons. The CH₂ group, centred around δ 3.34, showed a total of seven lines. This is one less than expected for this part of the AB system. It appears that the two inner lines may have coalesced, as the central line was noticeably broader than the other lines. The CH proton, at δ 4.80, was split by the neighbouring CH₂OH group and so a total of eleven lines were found. The CH₂OH group formed another ABX system with the hydrogen on C-5 of the isoxazoline ring. There were a total of eight lines for this AB portion of the ABX system which appeared centred around δ 3.53. The $^2J_{AB}$ was measured as 12.0 Hz and the corresponding $^3J_{AX}$ was 2.2 Hz and $^3J_{BX}$ was 3.5 Hz. The OH proton was found as a broad singlet at δ 3.49 and overlaps somewhat with the AB system of the CH₂OH.

The ¹³C NMR spectrum showed the CH₂OH group at δ 62.0 with the C-N double bond at δ 151.8 and the ethyl ester carbonyl at δ 160.4. The ring protons appeared at δ 84.0 for the CH and δ 34.6 for the CH₂. The other signals were due to the ethyl ester.

The mass spectrum showed a molecular ion at m/z 173 and the pattern of breakdown was similar to that seen for the other isoxazoles. IR spectroscopy showed the C-N double bond at 1645 and the OH at 3375 cm^{-1} .

The isoxazole produced by reacting methylvinylketone with ethyl chlorooximidoacetate was 5-methylcarbonyl-3-ethoxycarbonyl-2-isoxazoline (199). It was produced in 86% yield under standard conditions. The 5-substituted regioisomer was the only product produced. The ^1H NMR spectrum was similar to that of compound (198), but the methyl ester of compound (198) has been replaced with a methyl ketone which was found at δ 2.13. The ABX system was again present for the ring protons. These were found at δ 3.26 for the CH_2 and δ 4.96 for the CH. The ^{13}C NMR spectrum showed the ketone carbonyl at δ 205.1 with the C-N double bond at δ 151.7 and the ester carbonyl at δ 159.8. The ring CH was found at δ 86.1 and the CH_2 was present at δ 35.8. The methyl group of the ketone was found at δ 26.4. No NMR evidence was recorded for the formation of the nitrile oxide dimer.

Nitrile oxide 1,3-dipoles do not react as quickly with alkyl-substituted alkenes as they do with electron deficient or electron rich alkenes. This can be explained by frontier orbital theory. The theory predicts that for nitrile oxides the interaction of the frontier orbitals of the 1,3-dipole will not be as strong with simply substituted alkenes because neither the $\text{HOMO}_{\text{dipole}}\text{-LUMO}_{\text{dipolarophile}}$ or $\text{HOMO}_{\text{dipolarophile}}\text{-LUMO}_{\text{dipole}}$ interaction are close enough in energy to dominate the reaction.

This principle can be seen in action in the reaction of ethyl chlorooximidoacetate (192) with cyclohexene. The major product from this reaction was the nitrile oxide dimer (206) shown in **figure 99**. However it was possible to isolate 31% of the desired cycloaddition reaction product 4,5-cyclohexyl-3-ethoxycarbonyl-2-isoxazoline (203), which should have the same *cis*-geometry as the cyclohexene starting material.

Purification was required to remove the major product from the crude isolate. Once the isoxazoline (203) was separated the ^1H and ^{13}C NMR spectra confirmed that the product was indeed the cyclohexyl-substituted isoxazoline. The ^1H NMR spectrum showed the C-4 proton at δ 3.2 and it appeared as an unresolved broad quartet. This arises from the proton at C-4 coupling to the proton at C-5 and to the CH_2 of the cyclohexyl ring to which it is bound. There may also be W coupling to another CH on the cyclohexyl ring complicating the coupling pattern. The cyclohexane ring protons formed a complex multiplet at δ

1.5-2.1. The proton at C-5 on the isoxazoline ring was obscured by the triplet for the ethyl ester at δ 4.3-4.5.

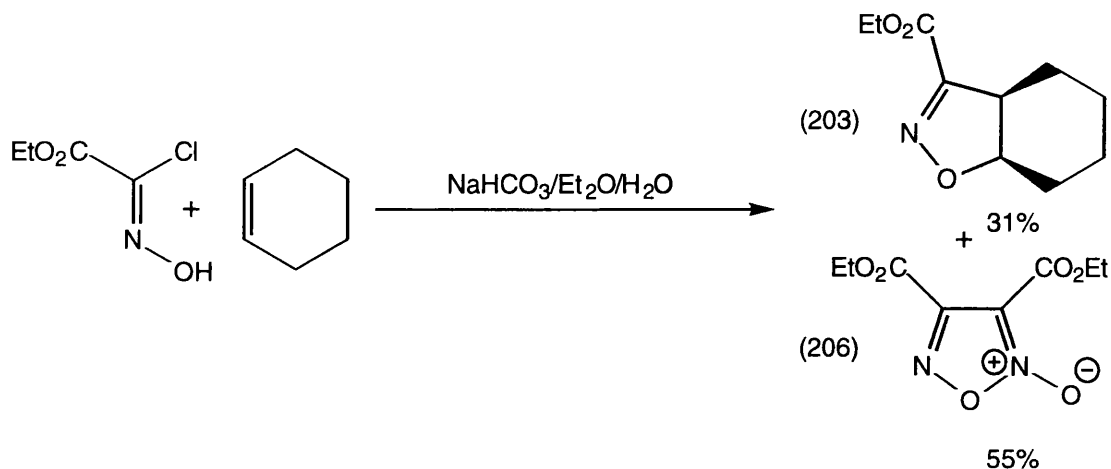


Figure 99: Reaction of cyclohexene with ethyl chlorooximidoacetate

The CH₂ groups for the cyclohexane ring were found at δ 19.6, 21.2, 24.5 and 25.4. The CH and CH₂ for the isoxazoline ring were found at δ 82.5 and δ 43.3 respectively. The ester carbonyl was found at δ 160.8 and the C-N double bond was at δ 157.7. Mass spectrometry gave a molecular ion peak at m/z 197 and the IR revealed a C-N double bond at 1627 cm⁻¹.

Some previous work with DHDPS had indicated the presence of a nucleophilic group near the active site.⁶⁶ It was decided that an isoxazole could be designed to be attacked by that nucleophilic group and might thus enhance any inhibition the compound might show against DHDPS. To that end ethyl chlorooximidoacetate (192) was cyclised with allyl bromide to produce 5-bromomethyl-3-ethoxycarbonyl-2-isoxazoline (202). The compound was isolated in 80% yield.

The ¹H NMR spectrum showed the expected two ABX systems for the CH₂ groups each coupling to the C-5H. The two AB parts of the ABX systems now overlap as can be seen in **figure 100**. They were found at δ 3.1-3.6. The 5-CH, at δ 5.0-5.2, was split into nine lines, as seen in **figure 100**. This was somewhat unexpected as the couplings to the two CH₂ groups should have resulted in a total of sixteen lines. Some overlap of peaks must be responsible for the reduction in the number of lines found.

The ¹³C NMR spectrum showed the two CH₂ groups at δ 32.5 (CH₂Br) and 38.2 (4-CH₂). The ring CH was found at δ 81.7 with the ester carbonyl at δ 160.2 and the C-N double bond at δ 151.3. The mass spectrum had peaks at m/z 235 and 237 which correspond to the molecular ions with either ⁷⁹ or ⁸¹Br.

Preparation of 5-formyl-3-ethoxycarbonyl-2-isoxazoline (200) involved reaction of ethyl chlorooximidoacetate (192) with acroelin. Acroelin was supplied as a 30% solution in water and the yield from the reaction was low at 5%. The ^1H NMR spectrum was consistent with the 5-substituted regioisomer with the aldehyde signal at δ 9.7, appearing as weak due to partial hydration, and the hydrated aldehyde was present at δ 4.8. The ring protons appeared at δ 3.3 for the 4- CH_2 and δ 5.2 for the 5- CH . The mass spectrum gave a peak at m/z 171 corresponding to the molecular ion, IR placed the C-N double bond at 1635 and the aldehyde at 1712 cm^{-1} .

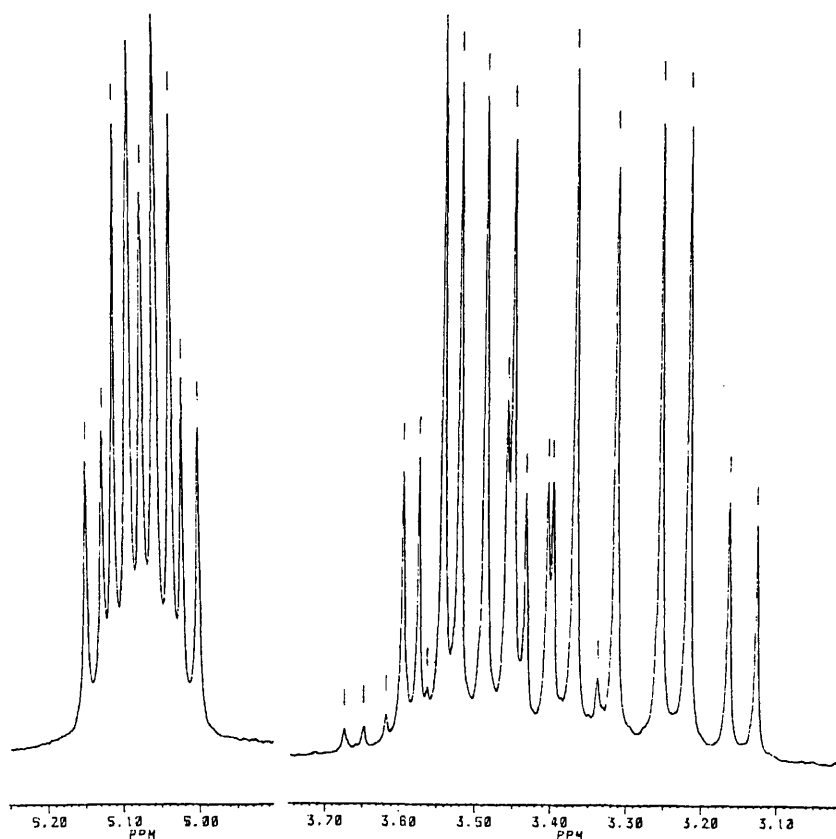


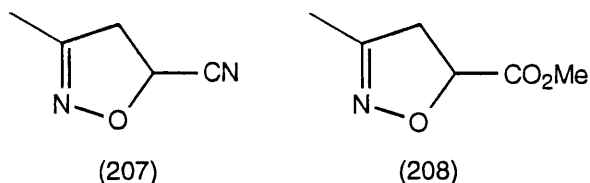
Figure 100: Part of the ^1H NMR spectrum of 5-bromomethyl-3-ethoxycarbonyl-2-isoxazoline showing two overlapping ABX systems

Attempts to generate the isoxazoles formed from cycloaddition with maleic anhydride (204) and dimethyl acetylenedicarboxylate (205) resulted in isolation of only the nitrile oxide dimer in varying amounts.

Preparation of isoxazoles via the Mukaiyama-Hoshino method¹⁸²

Two isoxazoles were prepared via this method which involved the treatment of nitroethane with phenyl isocyanate to generate the 1,3-dipole *in situ*. The two

isoxazolines prepared were 5-cyano-3-methyl-2-isoxazoline (207) and 5-methoxycarbonyl-3-methyl-2-isoxazoline (208). These were made to test the effect of removal of the ester group in the 2-position when the compounds were challenged with DHDPS.



5-Cyano-3-methyl-2-isoxazoline (207) was prepared in 66% yield from nitroethane. The ^1H NMR spectrum was similar to the ethoxycarbonyl substituted isoxazoline (197) prepared previously. The ring 5-CH was found at δ 5.2 and the 4-CH₂ was found at δ 3.4. The ABX system was still present for these protons and was further split by a, weak, long range coupling from the methyl group, see **figure 101**. For the A proton 4J was 1.1 Hz and for the B proton 4J was 0.9 Hz. The methyl group was found at δ 2.1. The ^{13}C NMR spectrum showed the CH at δ 65.8 and the CH₂ at δ 44.4 along with the C-N double bond at δ 155.6. The nitrile was found at δ 117.6 and the methyl group was found at δ 12.3.

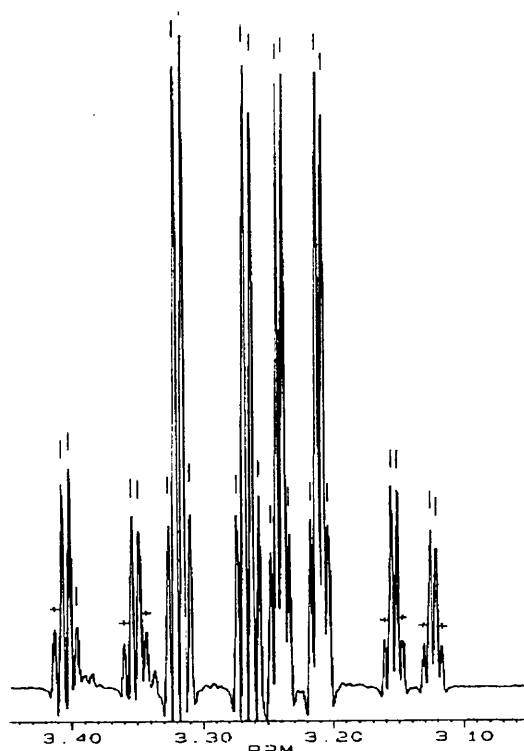


Figure 101: Long range coupling to the AB system of 5-cyano-3-methyl-2-isoxazoline

5-Methoxycarbonyl-3-methyl-2-isoxazoline (208) was prepared by the addition of methyl acrylate to nitroethane in the presence of phenyl isocyanate in a yield of 58%. The ^1H and ^{13}C NMR spectra confirmed the identity of the compound, with the spectra similar to those previously recorded for the other isoxazolines. There was an ABX system for the 5-CH and 4-CH₂ although it did not appear to be split further by the methyl group in the 2-position, as was seen for compound (207).

Preparation of isoxazoles using dienes

Two dienes were used to test the effect of further unsaturation on inhibitory effectiveness against DHDPS. The dienes used were 2,3-dimethylbutadiene (210) and methyl sorbate (209). They were expected to add to ethyl chlorooximidoacetate (192) regioselectively to give one major product (in the case of 2,3-dimethylbutadiene this is not a problem as the diene system is symmetrical). Methyl sorbate (209) was expected to produce the isoxazoline where the most electron deficient double bond had reacted. This product is shown in **figure 102**. Frontier orbital theory predicts that this double bond will provide the best orbital overlap.

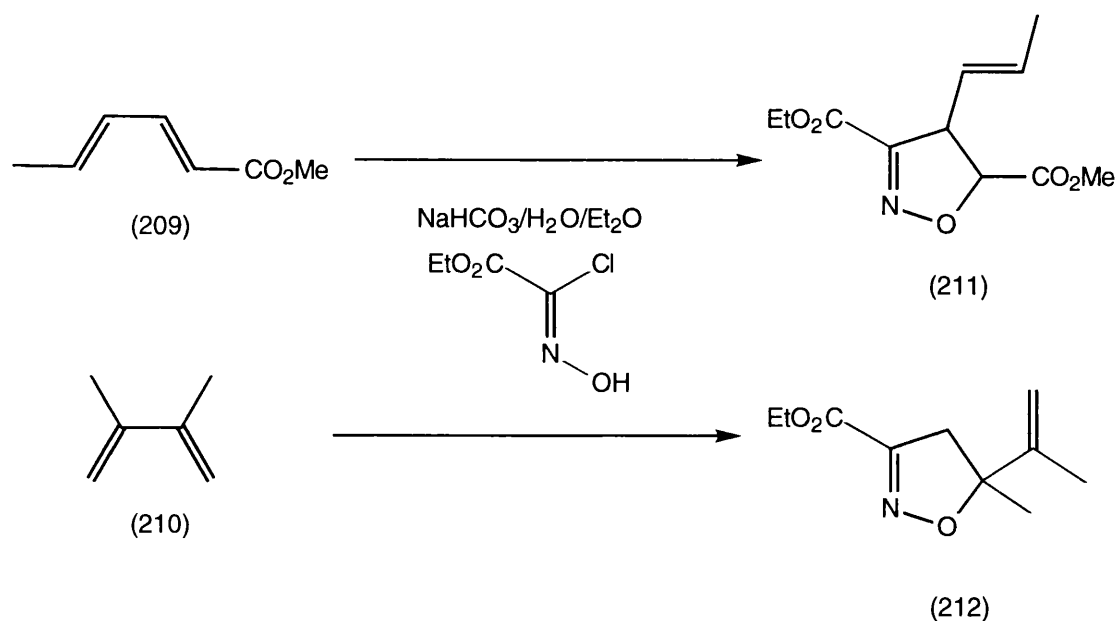


Figure 102: Addition of dienes to ethyl chlorooximidoacetate

Reaction of ethyl chlorooximidoacetate with 2,3-dimethylbutadiene (210) produced 5-(2'-propenyl)-5-methyl-3-ethoxycarbonyl-2-isoxazoline (212) in 48% yield.

The ^1H NMR spectrum confirmed the structure, with the CH_2 group on the isoxazoline ring being found at δ 3.1. There was no CH peak for the other regioisomer. The alkene CH_2 was found at δ 4.9 (this showed a fine splitting of about 1.4 Hz) and at δ 5.0 (a broad singlet). The methyl groups were found at δ 1.5 for the methyl group on the 5-position of the isoxazoline ring and δ 1.8 for the methyl group attached to the alkene. The CH_2 of the isoxazoline ring showed an AB system with an $^2J_{AB}$ coupling of 17.7 Hz, as seen below in **figure 103**.

Reaction of methyl sorbate (209) with ethyl chlorooximidoacetate failed to produce 5-(methoxycarbonyl)-4-(prop-1-ene)-3-(ethoxycarbonyl)-2-isoxazoline (211).

The reaction produced only the nitrile oxide dimer in varying yields. The diene, methyl sorbate (209) could not have been active enough to react with the nitrile oxide. This led to the nitrile oxide reacting with another molecule of the nitrile oxide to give the dimer.

Preparation of *t*-butyl 2-(*N*-(*t*-Butoxycarbonylamino)-3-(3-ethoxycarbonyl)-2-(isoxazolin-4-yl)propanoate

Good recognition in an enzyme's active site usually means keeping a similar structure to that of the enzyme's natural substrates and products. All of the isoxazolines prepared thus far have been product mimics. An attempt was made to keep the structure of ASA (23) as the basis of another potential inhibitor of DHDPs. To this end we prepared *t*-butyl 2-(*N*-(*t*-butylcarbonylamino)-3-(3-ethoxycarbonyl)-2-(isoxazolin-4-yl)propanoate (213) by reacting ethyl chlorooximidoacetate (192) with diprotected allylglycine (125), see **figure 104**. Compound (213) was isolated in an overall yield of 70%.

The ^1H NMR spectrum showed signals for the isoxazoline ring 5-CH and 4- CH_2 at δ 4.89 and 3.0 respectively. The α -proton of the amino acid was found at δ 4.4, where it appeared as a doublet of triplets with J 6.5 and 6.1 Hz. The CH_2

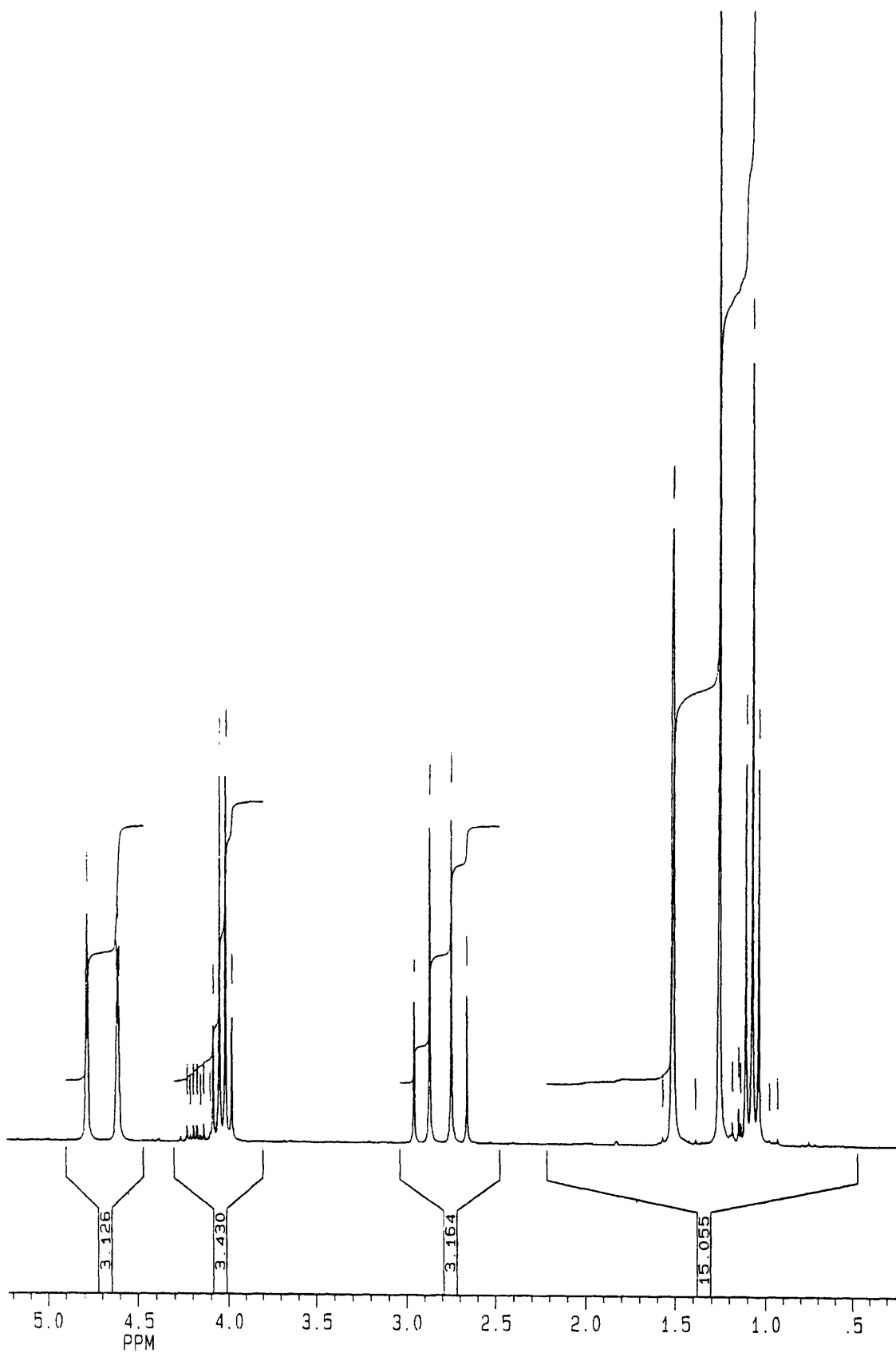


Figure 103: ¹H NMR spectrum of 5-(2'-propenyl)-5-methyl-3-ethoxycarbonyl-2-isoxazoline

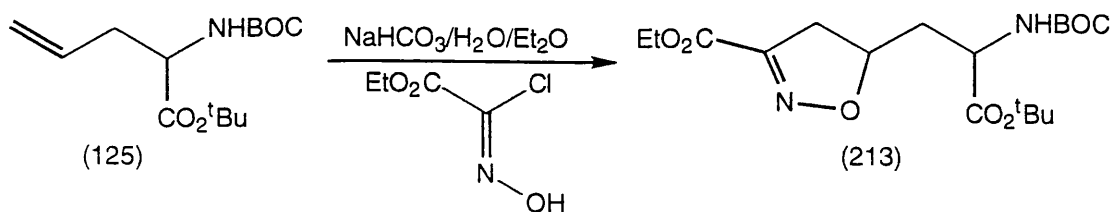


Figure 104: Reaction of ethyl chlorooximidoacetate with diprotected allylglycine

of the alanine side chain of the isoxazoline was found at δ 2.17. The ¹³C NMR spectrum showed the signals for the isoxazoline ring at δ 38.8, 80.0, 151.1 and 160.7. The α -carbon was found at δ 51.0 and the β -carbon of the amino acid was found at δ 37.3.

Mass spectrometry gave a peak at m/z 364 for the molecular ion and showed a similar pattern of fragmentation as for the other isoxazoles. The IR spectra showed the lack of a C-C double bond and the presence of a C-N double bond at 1640 cm⁻¹.

4.6 Ring opening of isoxazolines to give α -keto esters

Many methods have been reported to open the weak O-N bond of the isoxazoline ring system. These include hydrogenation with various metal catalysts, addition of electrons from sodium/ethanol and sodium amalgam systems.

Lithium aluminium hydride reduces 2-isoxazolines to 1,3-amino alcohols, see **figure 105**.¹⁸⁷ This is also the product isolated by reduction with borane complexes.¹⁸⁸ Hydrogenation produces either the keto-alcohol and an amino-alcohol depending on the conditions used for the reduction.¹⁸⁹ Titanous salts are known to cleave the N-O bond of isoxazolines. However the product from these reductions is often lacking the hydroxy group at the 3-position of the opened skeleton.¹⁹⁰ Sodium borohydride is known to remove the C-N double bond from isoxazolines when the R group in the 3-position is an acid or ester.¹⁹¹

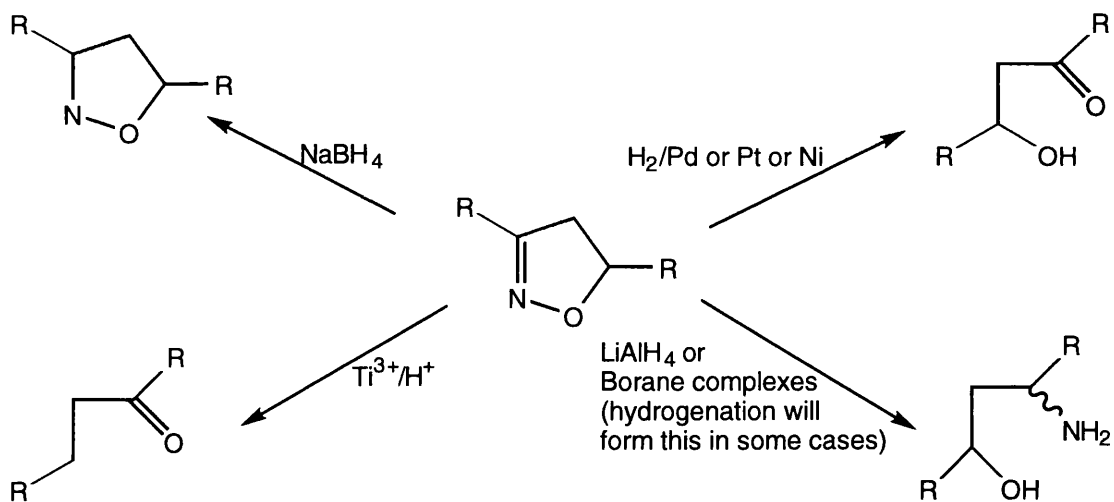


Figure 105: Methods of cleavage for the N-O bond of isoxazolines

The method we chose to reduce some of the 2-isoxazolines made was catalytic reduction using hydrogen and palladium on charcoal. We wanted to obtain some keto-esters that may act as pyruvate analogues when they are challenged with DHDPS. To this end we chose to reduce catalytically 5-hydroxymethyl-3-ethoxycarbonyl-2-isoxazoline (198), 5-methylcarbonyl-3-ethoxycarbonyl-2-isoxazoline (199) and 5-methoxycarbonyl-3-ethoxycarbonyl-2-isoxazoline (201). All were treated with palladium on carbon under an atmosphere of hydrogen gas for eighteen hours before being acidified and stirred for a further one hour. Basification followed by extraction and purification gave the corresponding keto-esters, see **figure 106**.

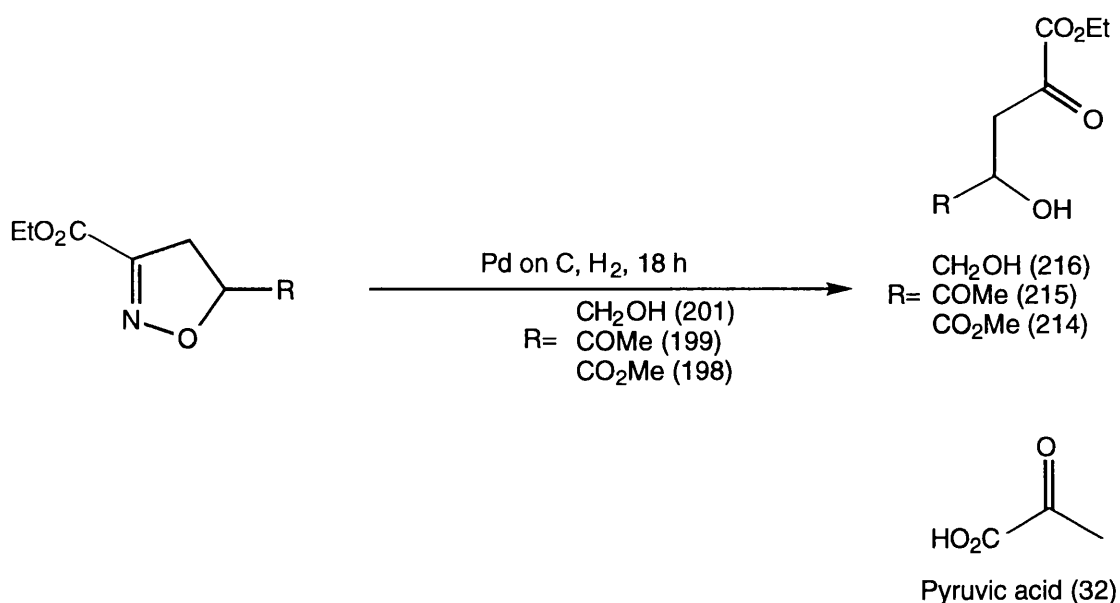


Figure 106: Reduction of isoxazolines using Pd on carbon

The three isoxazolines were transformed into the keto-esters in low yields, none greater than 16%. The reason for the low yields was attributed to the formation

of amino alcohols by the further reduction of the imine formed on initial cleavage of the N-O bond. This, as mentioned above, was a known reaction and prevented the isolation of large quantities of these compounds.

The ^1H NMR spectra of these compounds were very similar to those recorded for the corresponding isoxazoline ring systems. The major difference was the presence of a broad singlet at δ 6.9, 5.4 and 4.4 for compounds (214), (215) and (216), respectively, attributed to the hydroxyl proton. This was confirmed by the IR spectra where the presence of a hydroxyl group was quite pronounced. The hydroxyl of compound (214) appeared at 3415 cm^{-1} and for compound (216) it was found at 3395 cm^{-1} .

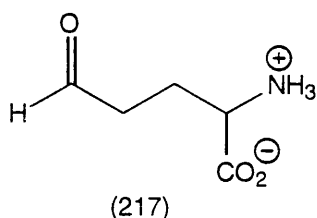
It was initially intended that the esters would be cleaved to produce the free acids. These would have been more electronically and sterically like pyruvic acid at the end of the molecule recognised by DHDPS. Time constraints and the poor yields of the ring opened compounds prevented the production and testing of the free acids.

These three ring opened compounds and all of the other isoxazoles were tested with DHDPS. The results of the testing can be found in chapter eight.

Chapter Five: Attempted Synthesis of Glutamic Acid γ -Semialdehyde

5.1 Introduction

Glutamic acid γ -semialdehyde (GSA) (217) is the higher homologue of ASA (23). It is itself a biologically important compound as it is a common intermediate in the enzymatic interconversions of glutamic acid, proline and ornithine.¹⁹² While testing a variety of compound types as inhibitors of DHDPS it was decided that GSA (217) would be an interesting compound to prepare for use in our inhibitor studies and also as a potential substrate for DHDPS.



There have been many reports of GSA (217) being prepared as a diprotected species in the literature. Bold *et al.*¹⁹³ prepared GSA (217) doubly protected on the amine and the carboxyl functionalities via the Rosenmund reduction reaction. The doubly protected semialdehyde was used directly in further transformations. Lee and Miller¹⁹⁴ made the protected semialdehyde by reduction of the corresponding acid chloride (218) with a hydride agent such as tributyltinhydride or lithium tri-*tert*-butoxyaluminumhydride, see **figure 107**. The protected semialdehyde (219) they prepared was not deprotected.

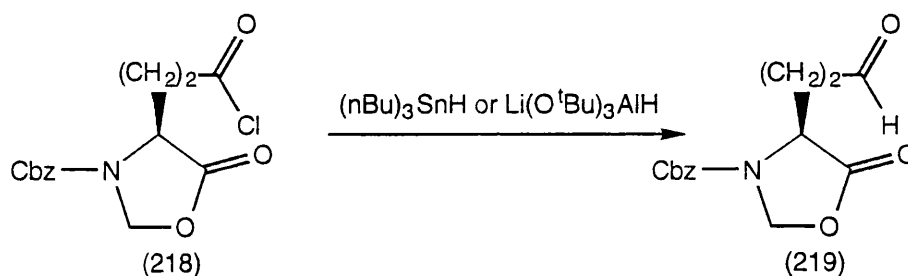


Figure 107: Lee and Miller preparation of diprotected GSA

A Japanese patent described a process for preparing optically active *N*-acetylglutamic semialdehyde from the oxidation of optically active *N*-acetylornithine with persulfate. The product was formed in aqueous solution and was not isolated.

5.2 Synthesis of glutamic acid γ -semialdehyde

We desired to synthesise GSA (217) as a solid, such as was obtained from the synthesis of ASA (23). We had envisaged a final step involving deprotection of diprotected GSA using TFA. It was decided to start the synthesis from L-glutamic acid (220) to take advantage of the natural optical activity of the amino acid. The synthetic plan is outlined in **figure 108**. The glutamic acid (220) would be fully protected and then the γ -ester would be removed selectively to produce the free acid. This acid group would then be reduced selectively to the aldehyde using a dissolving metal reduction, trapping the aldehyde as the imine.

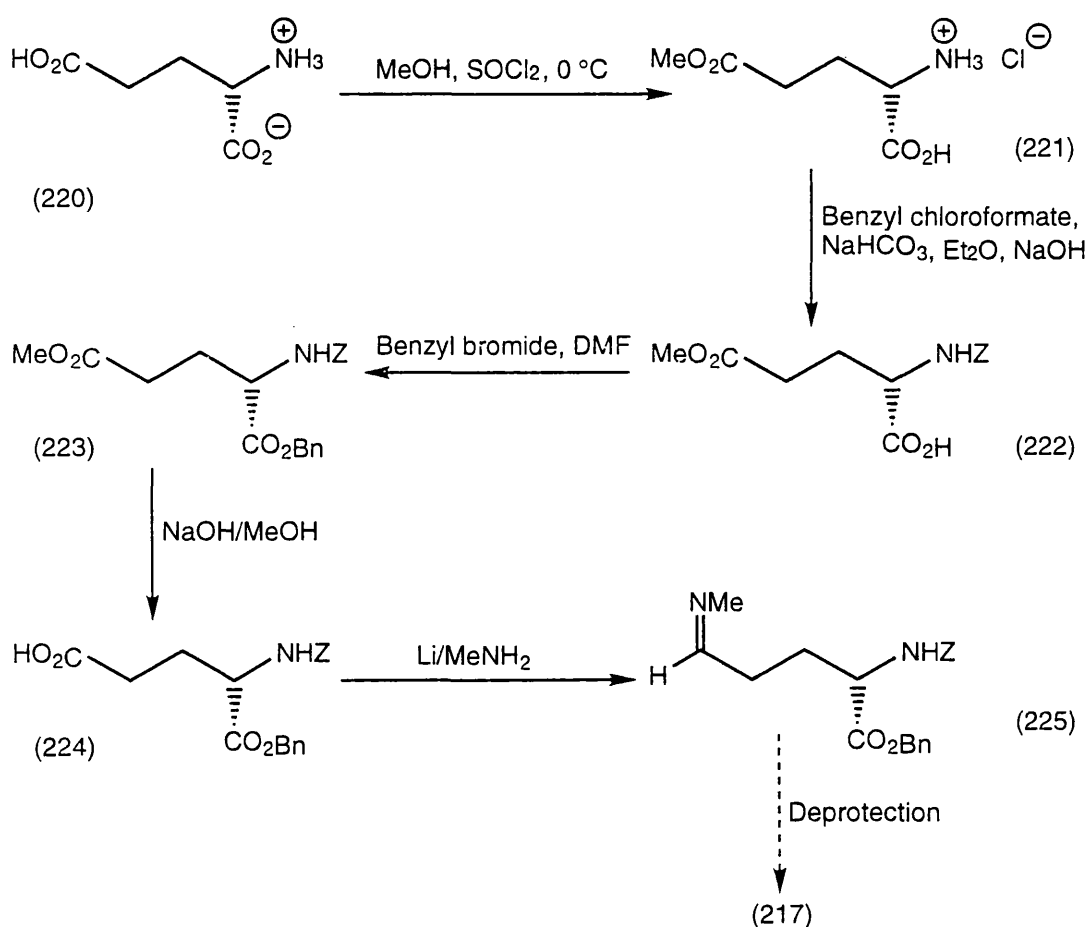


Figure 108: Synthetic plan towards GSA (217)

Glutamic acid (220) was protected as its methyl ester at the γ -carboxyl to produce (221), using thionyl chloride and methanol in 79% yield. This was then treated with benzyl chloroformate and sodium bicarbonate to produce the *N*-Cbz diprotected compound (222) in 77% yield. The final protecting group was added by stirring compound (222) in DMF with benzyl bromide for 24 hours. The benzyl ester (223) was prepared in 50% yield from compound (222).

The methyl ester was selectively hydrolysed by stirring compound (223) in methanol and 2M sodium hydroxide solution at room temperature. The free acid (224) was recovered in 91% yield from (223).

Two reports indicated that the reduction of acids could be accomplished directly to aldehydes in the presence of lithium dissolved in a liquified amine (either methylamine or ethylamine).^{195,196} The procedure involved the addition of the acid to be reduced into a solution of lithium and methylamine at -78 °C. The acid under these conditions was reduced to the aldehyde. The initial product was found to be an imine, which under the work-up conditions was hydrolysed to the aldehyde. The reaction was not thought to progress through the imine until a late stage as under the reaction conditions, imines would be reduced to amines. Bedenbaugh *et al.*¹⁹⁶ believed that the reaction involved the formation of a carbinolamine salt, which was converted into an imine during the isolation.

Treating compound (224) under the conditions detailed should have provided diprotected GSA, after hydrolysis of the imine. Work-up of the reaction, by extraction into ether and concentration under reduced pressure left an inseparable mixture of products. By NMR spectroscopy no evidence could be found for any reduced acid. The reduction was repeated on the *t*-butyl protected ester (228), see **figure 109**. The same result was obtained and no reduced product could be identified from the isolated product mixture.

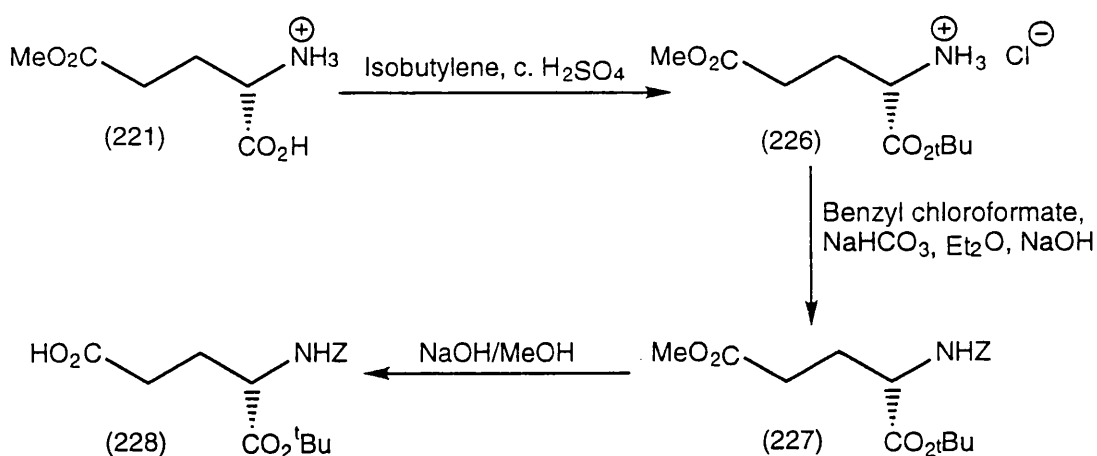


Figure 109: Preparation of *t*-butoxy-*N*-(benzylcarbonylamino)propane-1,3-dicarboxylate (228)

These results are probably due to the conditions of the reduction and the fact that benzyl radicals are easily formed and “stable”. Under the conditions it was believed that benzyl radicals would be generated, probably causing the destruction of the compound. Another possibility was that the deprotected

compound would no longer be organic miscible and would therefore not be isolated in the work-up.

The failure of the reduction of (224) or (228) to GSA (217) led to a change in direction. Glutamic acid (220) was still the precursor, but the plan now was to reduce the γ -acid group and oxidise it to the aldehyde as seen in **figure 110**.

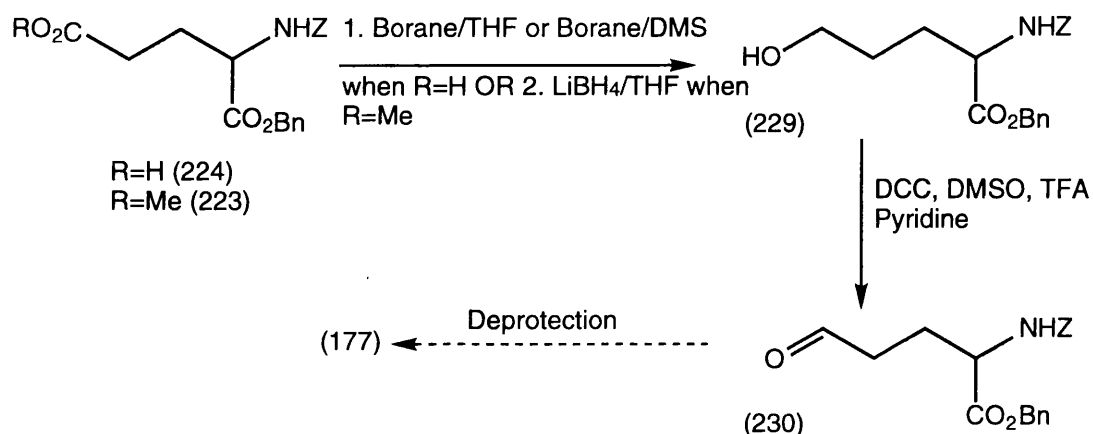


Figure 110: Alternative route to GSA (230)

Starting from compound (224) the acid group was to be reduced to the corresponding alcohol (229). Boranes are well known to carry out this conversion without reducing the other functionality of the molecule.¹⁹⁷ Attempts with both borane/THF and borane/dimethylsulfide failed to reduce the acid (224). The ¹H and ¹³C NMR spectra still showed a signal due to the acid group at δ 10.1 in the ¹H NMR spectrum and δ 178.1 in the ¹³C NMR spectrum.

A report by Brown and Narasihnman¹⁹⁸ detailed the use of lithium borohydride as a reducing agent for carboxylic esters. The paper suggested that when lithium borohydride was heated at reflux in THF with compound (223) the methyl ester should be reduced about five times quicker than the benzyl ester. Upon reaction of (223) with lithium borohydride and isolation of the products, a 60% yield of the alcohol (229) was achieved. The ¹H NMR spectrum showed the alcohol CH₂ at δ 3.5 and in the ¹³C NMR spectrum the CH₂ was found at δ 63.6. The NMR spectra also revealed that the benzyl ester had also been partially cleaved under the conditions used for reduction. A small amount of reduced δ -ester and reduced benzyl ester was also recovered from the reaction mixture. It was decided to use the material isolated for the oxidation in an attempt to produce *N*-benzyl GSA.

A selective oxidation method was required that would stop at the aldehyde oxidation level and not produce any acidic material by over-oxidation. A

modification of the Swern oxidation was chosen.¹⁹⁹ This method used DCC instead of oxalyl chloride to activate DMSO. The mechanism of this reaction can be seen in **figure 111**. DMSO attacks the DCC to form the complex shown as (231) in **figure 111**. This is then attacked by the hydroxyl group of the compound being oxidised to form the alkoxysulfonium species (232). Proton abstraction then completes the oxidation with dimethylsulfide and dicyclohexylurea as by-products.

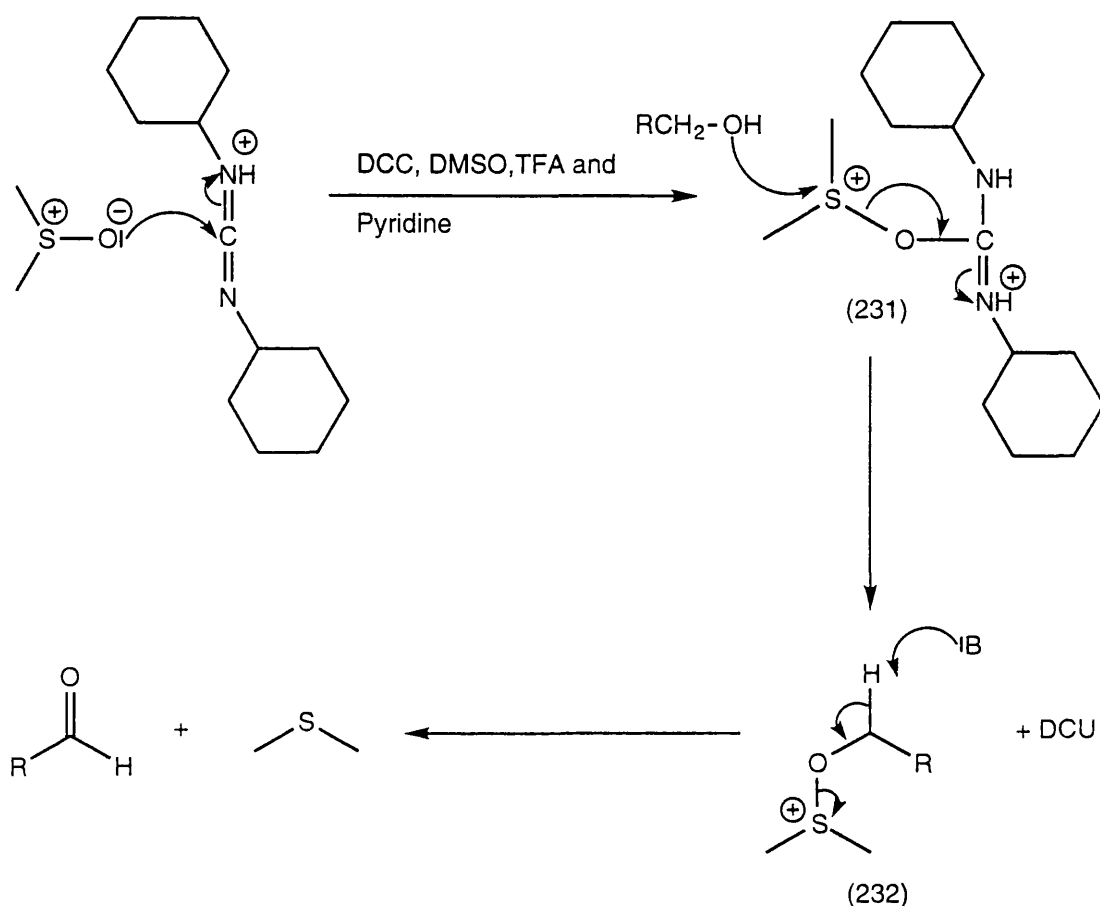
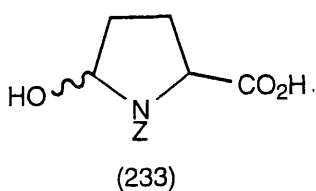


Figure 111: Oxidation of alcohols to aldehydes using a Swern type reaction

Oxidation of the isolated alcohol under the conditions outlined above gave a 51% yield of an oil. The ¹H and ¹³C NMR spectra suggested that the compound had cyclised to form a protected 5-hydroxyproline derivative (233).



No signal was seen for the expected aldehyde of (233), but a complex multiplet at δ 5.5 was seen for the 5-H in the ^1H NMR spectrum. This was probably due to the presence of diastereoisomers in the ^1H NMR spectrum. The rest of the ^1H and ^{13}C NMR spectra were complicated by the presence of both diastereoisomers.

It was clear that this route could not be used to produce GSA for testing with DHGPS. Other workers in our group had encountered the same problem of cyclisation whilst using various other protecting groups on the nitrogen. The *N*-acetyl protected compound also undergoes cyclisation. It may not be possible to produce GSA in a deprotected form to test due to its tendency to exist as the cyclic product. The only way may be to produce a protected aldehyde and then carry out the deprotection *in situ*. This may enable the enzyme to bind and react before the compound cyclises. Imines or acetals may be required as protecting groups for the aldehyde because they can be removed under mild conditions and without damaging the enzyme.

5.3 Studies towards the enzymic product of GSA and pyruvate

If GSA (217) does bind to DHGPS and condenses with pyruvic acid (32) a seven-membered diene (234) will be formed. This would not be detected at the wavelength at which we monitor the assay. The assay is designed to detect the formation of the aromatic species dipicolinic acid (33).

What will be described below is a route towards the diene (234) detailing the first few stages of the pathway. The rest of the route is suggested for the synthesis of the diene (234). It may be that another co-worker will take up the synthesis, but the priorities of the group have since moved away from GSA (217).

As for the condensation of ASA (23) with pyruvate (32) to form DHPD (27), GSA (217) may condense with pyruvate (32) as shown in **figure 112**. The product is now no longer capable of becoming aromatic and the diene (234) may be isolated or trapped.

A recent paper by Evans, Holmes and Russell²⁰⁰ detailed the synthesis of 7-substituted tetrahydroazepin-2-ones via a Claisen rearrangement. They prepared compounds with the structure shown as (235) in **figure 113**. Their starting materials were amino acids.

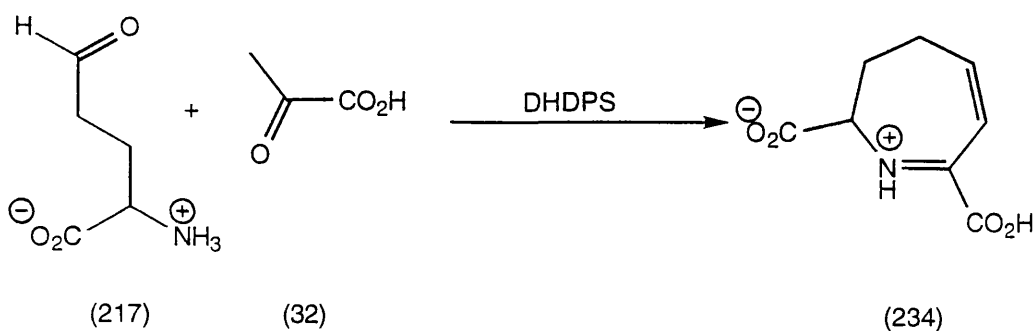


Figure 112: Condensation of GSA with pyruvate

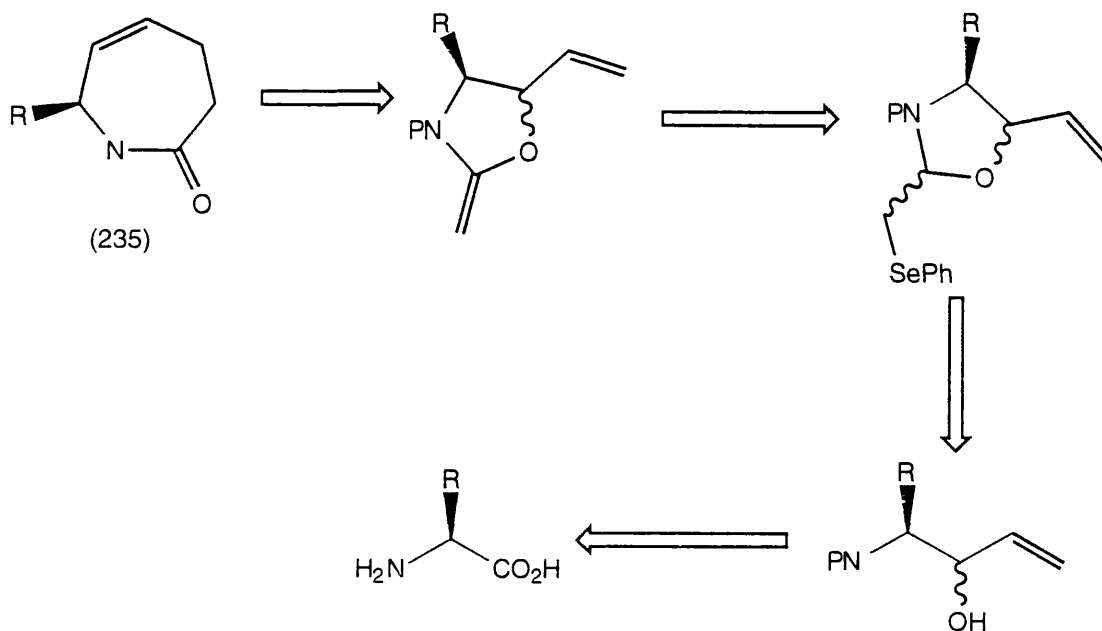


Figure 113: Retrosynthetic analysis of 7-substituted tetrahydroazepin-2-ones

L-Serine (236) was chosen as the starting point for the synthesis of (234), as outlined in **figure 114**. L-Serine (236) was first protected as its *N*-benzyloxycarbonyl derivative (237) using benzyl chloroformate under basic conditions. The carbamate was isolated as a solid in 98% yield, and melting points confirmed the identity of the compound, with mp 118-119 °C (lit.²⁰⁰ 117-119 °C). The *N*-protected amino acid was then treated with thionyl chloride and anhydrous methanol to form the methyl ester (238), which was isolated as an oil in 97% yield. The diprotected amino acid ester (238) crystallised with time and a white solid with a melting point of 39-40 °C (lit.²⁰⁰ 38-40 °C) was recovered.

Treatment of the diprotected amino acid ester (238) with 2,2-dimethoxypropane and PTSA as a catalyst produced an acetonide ester (239) in 81% yield. The 2,2-dimethoxypropane acts as an acetone equivalent when treated under acidic conditions, see **figure 115**.

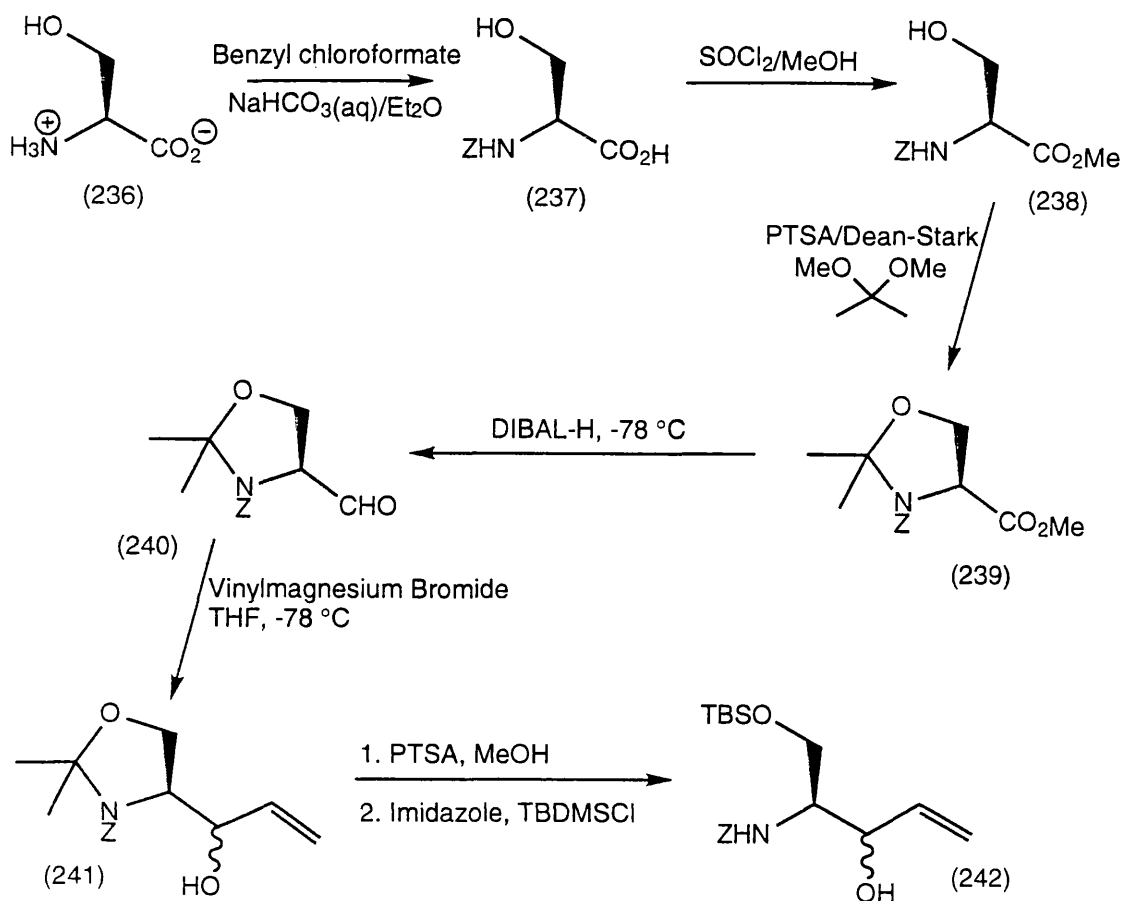


Figure 114: Towards diene (234)

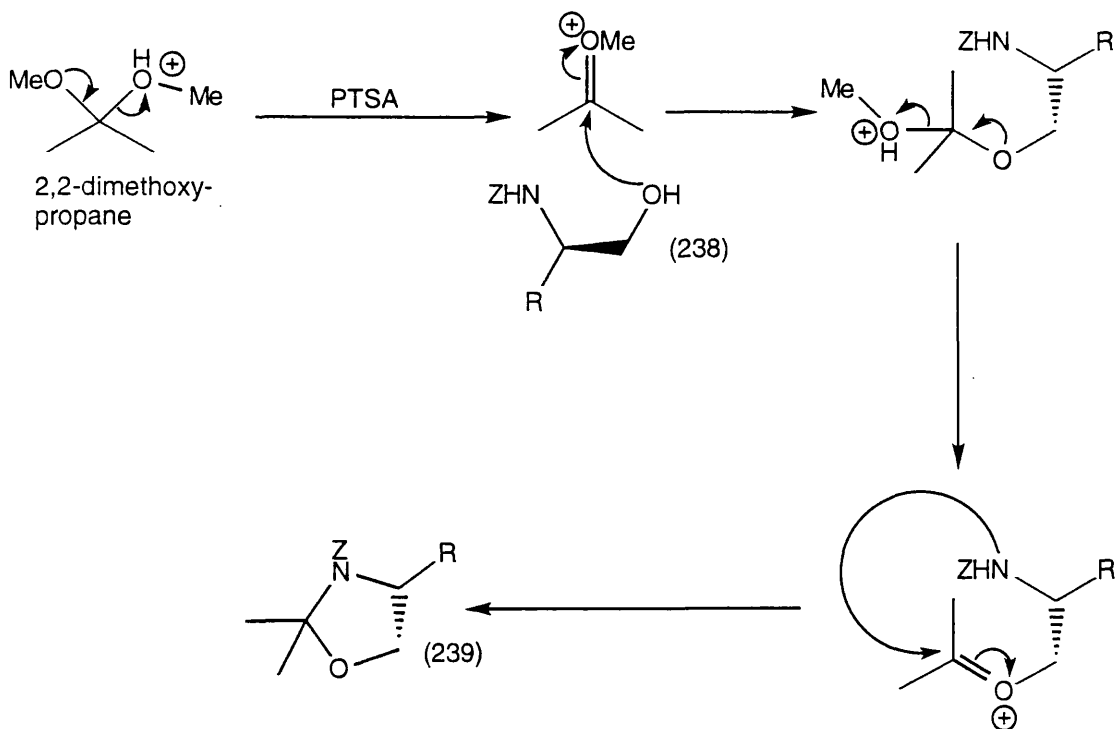


Figure 115: Formation of the oxazolidine ring system

The ^1H NMR spectrum of the oxazolidine (239) appeared more complex than the assigned structure would indicate, see **figure 116**. The oxazolidine exists at room temperature as a mixture of rotamers.^{201,202} The two ring methyl groups appeared as four separate signals at δ 1.70, 1.64, 1.56 and 1.48, two for each methyl group. The height of the signals is proportional to the percentage of molecules in that particular rotameric form. There were also two sets of peaks for all the signals except the benzene ring; these presumably overlap and are not seen as two distinctly separate resonances.

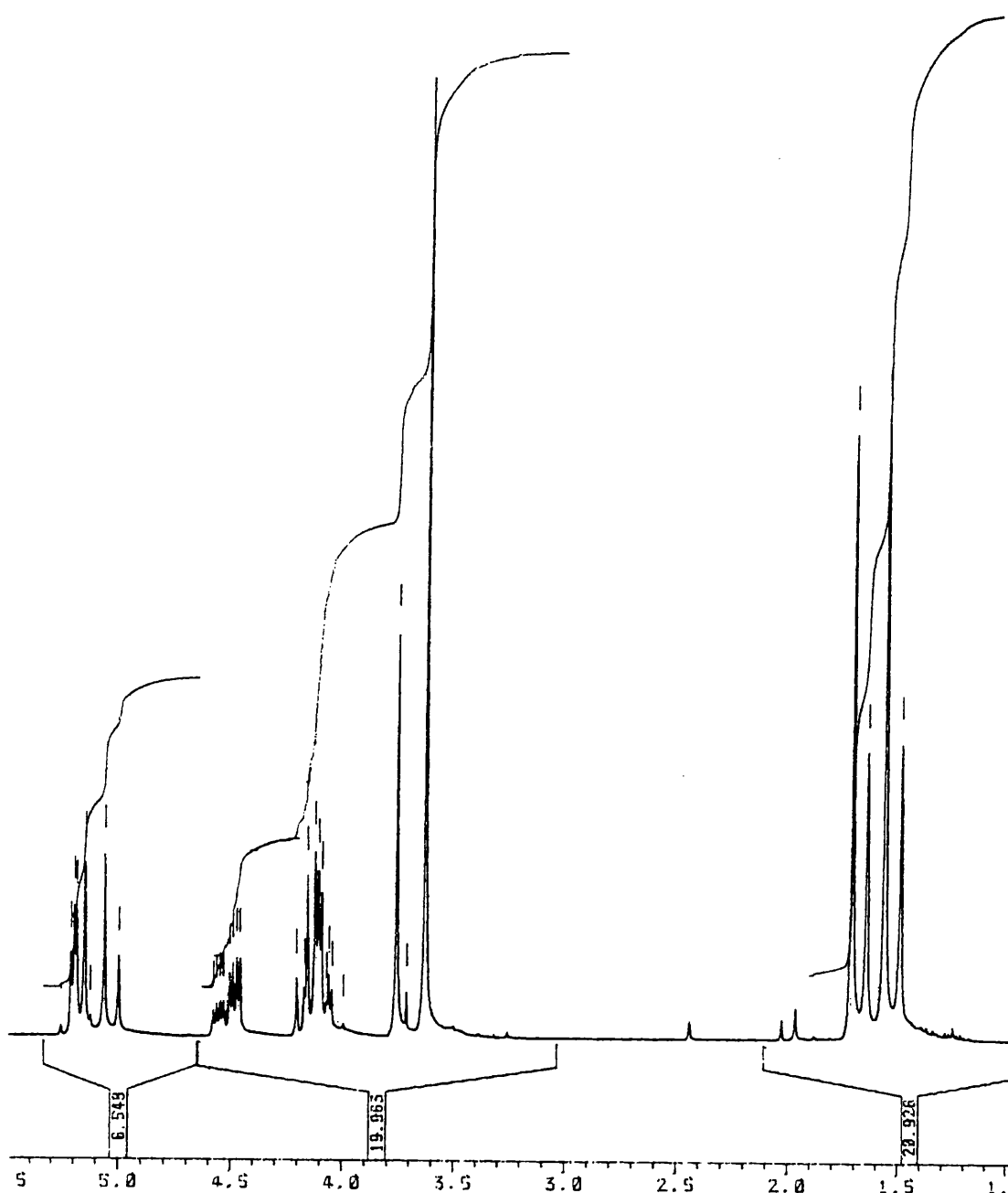


Figure 116: ^1H NMR spectrum of methyl (4S)-3-benzyloxycarbonyl-2,2-dimethyloxazolidine-4-carboxylate (198)

The reduction of (198) to the aldehyde (240) was achieved in 97% yield using DIBAL-H in toluene. The temperature was kept below $-78\text{ }^{\circ}\text{C}$ for the duration of the reaction and chromatography was required to purify the aldehyde. The ^1H and ^{13}C NMR spectra show the aldehyde at δ 9.4 and 9.6 in the ^1H spectrum and at δ 199.0 in the ^{13}C NMR spectrum. All other signals, except the benzene ring, show the effects due to the presence of rotameric isomers.

Attempts to reproduce the Grignard reaction as detailed in the paper of Holmes and co-workers²⁰⁰ led to the complete decomposition of the aldehyde (240). Careful dropwise addition of vinylmagnesium bromide to a stirred solution of the aldehyde was successful in producing compound (241) in a yield of 91%. The signals for the alkene hydrogens were found at δ 3.9-4.1 for the alkene CH and δ 5.7-6.0 for the terminal CH_2 group in the ^1H NMR spectrum. The terminal alkene CH_2 was found at δ 116 and 118 in the ^{13}C NMR spectrum with the alkene CH being found amongst the CH signals for the benzene ring carbons at δ 128-130.

Ring opening of compound (241) produced the mono-protected diol (242). This was achieved using a two stage procedure which involved first the removal of the oxazolidine ring, and then the protection of the primary alcohol using *tert*-butyl(dimethyl)silyl chloride and imidazole. The reaction was achieved with a yield of 57% for the two steps. Time constraints prevented the further development of this route towards diene (234). The possible conversion of (242) into diene (234) is outlined in **figure 117**.

5.4 Future work

Compound (242) could be transformed into the tetrahydroazepin-2-one (243) by the Claisen rearrangement as shown in **figure 113**, for the retrosynthetic direction. Compound (244) could be prepared by reacting (242) with phenylselenenylacetaldehyde diethyl acetal and then oxidative *syn*-elimination to give the diene (244), which on heating should undergo a Claisen rearrangement to give the tetrahydroazepin-2-one (243). This could then be transformed into the diene (234) by means of the pathway outlined in **figure 117**.

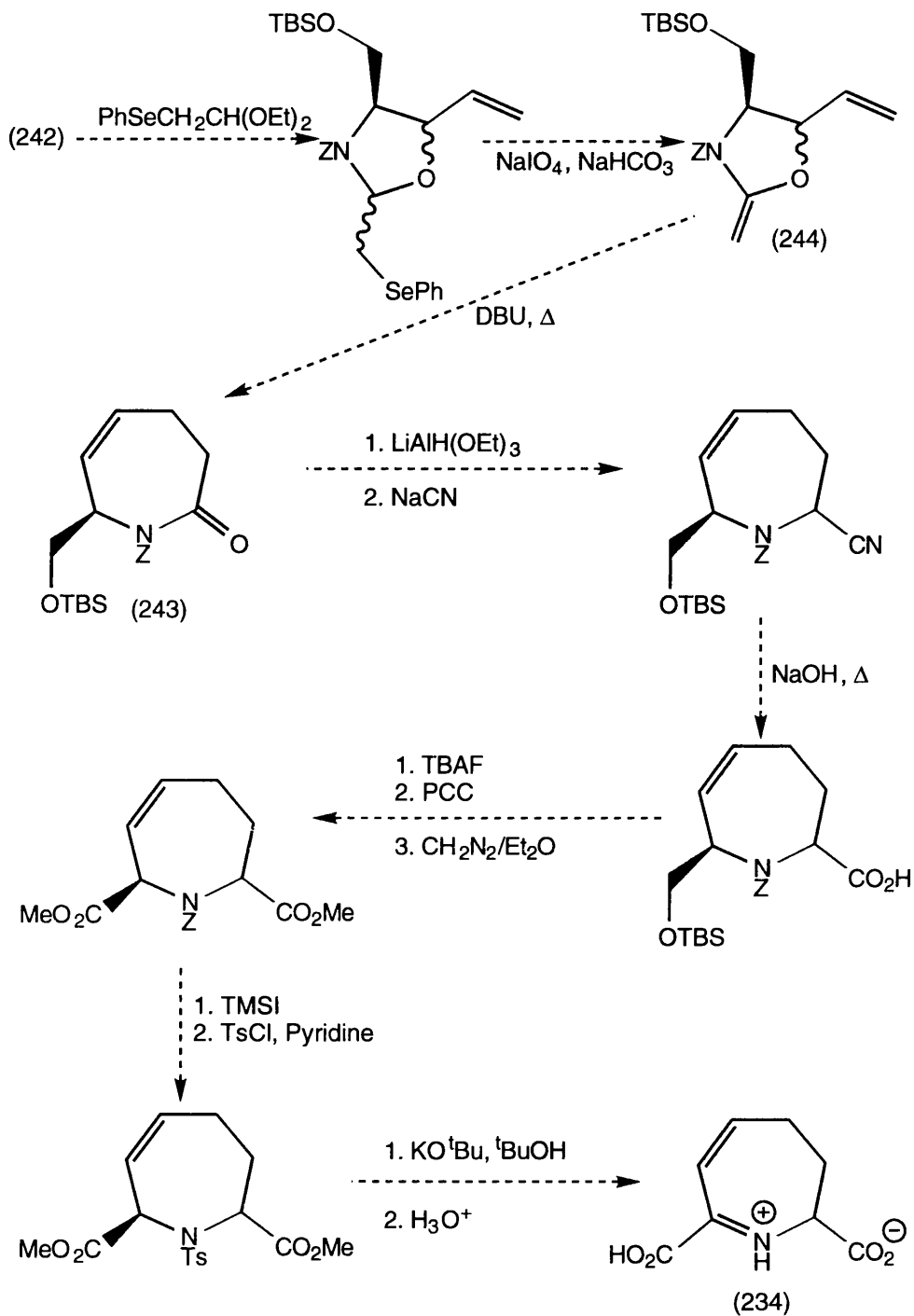


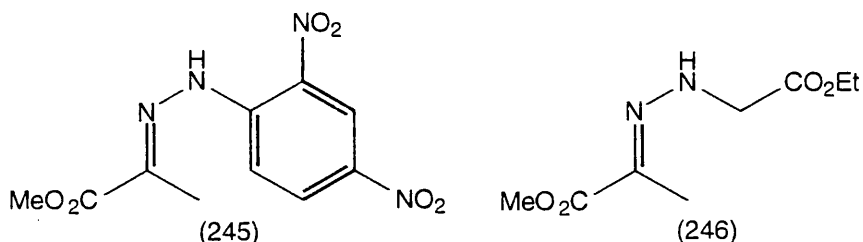
Figure 117: Planned conversion of (242) into (234)

Chapter Six: Synthesis of Inhibitors of DHDP Synthase

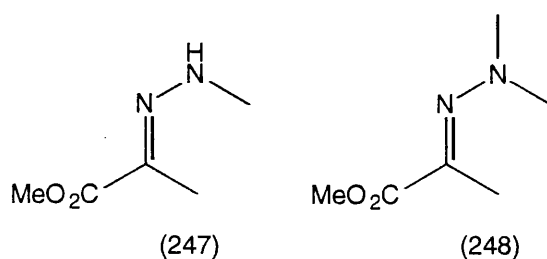
A series of compounds of varying structural types was synthesised as potential inhibitors of DHDPs. These included a couple of pyruvate analogues and some piperidinedicarboxylic acids. Other compounds were aromatic product analogues, differing only in their 2,6-substituents. Attempts were also made to reduce chelidonic acid to the 4-hydroxytetrahydropyran derivative. Other work towards morpholines will be discussed, indicating possible reasons for failure.

6.1 Pyruvate analogues

Pyruvate analogues have been extensively studied by previous co-workers at Glasgow. Dr D. Tudor and Dr. S. Connell prepared a large number of pyruvate derivatives which were tested against DHDPs. These compounds provided both good and poor inhibitors. The bulkier derivatives were reasonably poor [e.g. 2,4-DNP derivative (245) did not inhibit DHDPs] but compounds such as the ethyl hydrazinoacetate (246) gave 62% inhibition at a concentration of 1 mM.



In order to complete this area of work a couple of pyruvate analogues (247) and (248) were prepared. They were prepared by stirring methyl pyruvate in ethanol and then adding either methylhydrazine or 1,1-dimethylhydrazine. Compound (247) was isolated in 75% yield and (248) was prepared in 71% yield. Confirmation of the formation of these compounds was found in the ^{13}C NMR spectra where the C-N double bond was found at δ 130.6 and 144.6 for compounds (247) and (248), respectively. Attempts to prepare the corresponding derivatives from bromopyruvate were unsuccessful, yielding only a complex mixture of organic materials.



6.2 Saturated analogues of DHDP

The product of the condensation of ASA (23) with pyruvate (32), as catalysed by DHDPS is L-DHDP (27). It seemed reasonable to assume that fully saturated piperidine ring systems might provide potential inhibitors of DHDPS.

Cis- and *trans*-piperidine-2,6-diacids were prepared by the method of Couper *et al.*⁷⁶ and these were then converted into the dimethyl esters to test for activity with DHDPS. The *cis*-diester (249) was prepared by the hydrogenation of dimethyl dipicolinate using platinum oxide and formic acid in 94% yield, see **figure 118**. Formation of the *N*-methyl dimethyl ester (250) was then carried out in 75% yield using formaldehyde, formic acid and sodium bicarbonate.

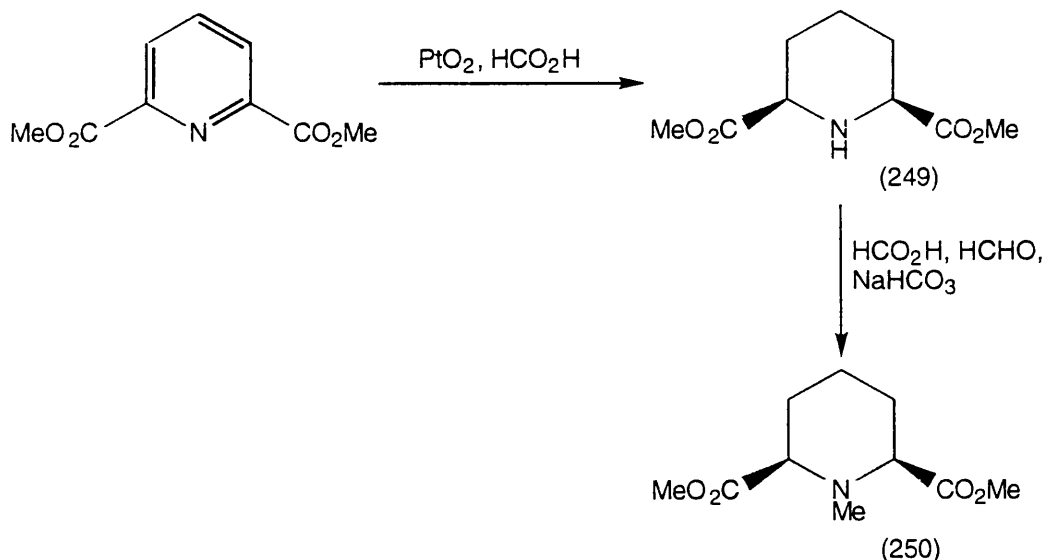


Figure 118: Formation of *cis* piperidine-2,6-dicarboxylic acid derivatives

The *trans*-diesters were prepared from *trans*-piperidine-2,6-dicarboxylate and the corresponding *N*-methyl compound. These were obtained from a former co-worker Dr. L. Couper. Treatment of these two compounds, see **figure 119**, with acetyl chloride and methanol gave the esters (251) and (252) in 79 and 69% yields, respectively.

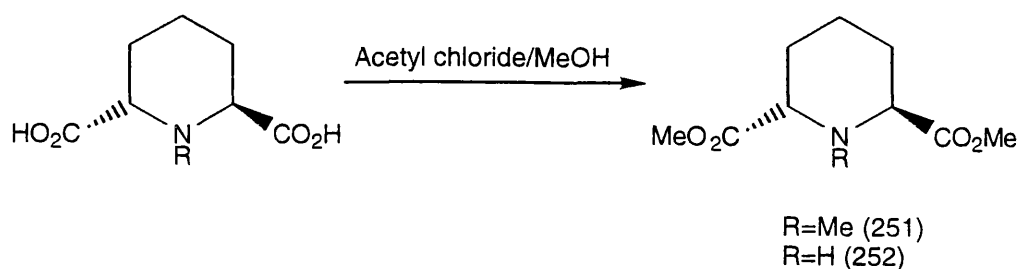


Figure 119: Formation of the *trans*-diesters

Testing of the diesters (249)-(252) along with the pyruvate analogues (247) and (248) will be discussed in the next chapter.

6.3 Aromatic analogues of DHDP

The aromatic compound dipicolinic acid (33) was found to be an inhibitor of *E. coli* DHDPs. This led to the synthesis of a number of aromatic species designed to be inhibitors of DHDPs. These included the ditetrazole (41), diimidate (42), dinitrile (43), *N*-oxide (44) and the diamide (254), see **figure 120**. These had been prepared previously by Dr. L. Couper but were never properly tested.

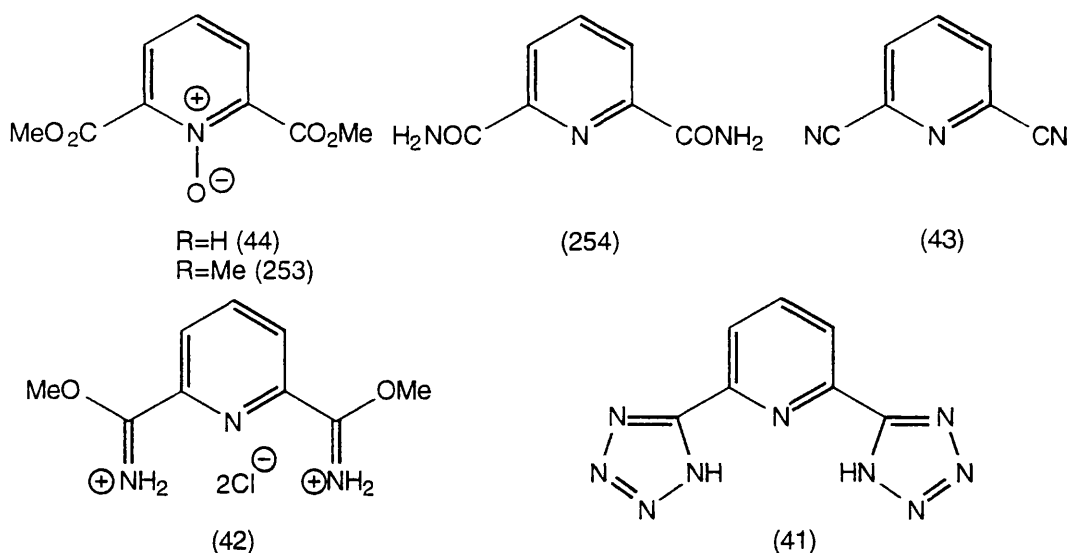


Figure 120: Aromatic inhibitors of DHDPs

Dimethyl pyridine-2,6-dicarboxylate *N*-oxide (253) was prepared from DPA (33) using *m*-chloroperbenzoic acid in dichloromethane,⁷⁶ a procedure modified from that used by Dr. L. Couper for the preparation of *N*-oxides. The compound was isolated as a white solid in 78% yield. Mass spectrometry identified the solid as the *N*-oxide (253) with a peak at *m/z* 211 corresponding to the molecular ion.

The other compounds were all prepared from the diamide of pyridine-2,6-dicarboxylic acid (254), see **figure 121**. The diamide was produced by quenching the acid chloride, formed on heating pyridine-2,6-dicarboxylic acid at reflux with thionyl chloride, with saturated ethereal ammonia. The diamide (254) was recovered in 66% yield from DPA (33). A molecular ion peak was found in the mass spectrum at m/z 165.

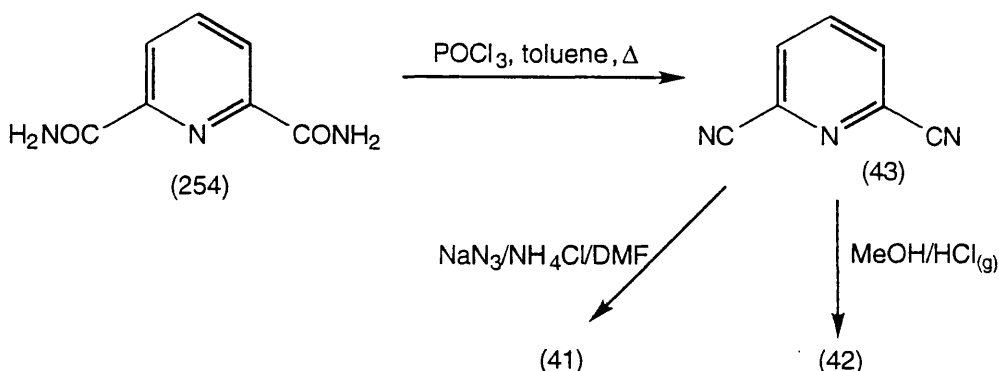


Figure 121: Synthetic modification of pyridine-2,6-dicarboxamide

Dehydration of the diamide was attempted to produce the dinitrile (43). The conditions used were heating at reflux a solution of (254) in toluene with phosphorus oxychloride. The reaction went a black colour and after the work-up a brown solid was obtained. This solid was recrystallised from chloroform five times until a white solid was isolated. The overall yield of this procedure was 10%. The dinitrile showed a peak at δ 115.5 in the ^{13}C NMR spectrum, diagnostic of the formation of the dinitrile. The mass spectrum gave a peak at m/z 129 for the molecular ion of the dinitrile.

Reaction of the dinitrile (43) with sodium azide and ammonium chloride at reflux produced the ditetrazole (41) in 90% yield. The ditetrazole is presumably formed via a 1,3-dipolar cycloaddition of azide onto the nitrile (43). Mass spectrometry gave a peak at m/z 215 corresponding to the molecular ion of the ditetrazole (41).

The final compound of the series was the diimidate (42), which was produced from the dinitrile (43) by reacting with dry hydrogen chloride in the presence of anhydrous methanol. On cooling the diimidate (42) crystallised from solution. The diimidate (42) was recovered in 10% yield. The ^{13}C NMR spectrum showed the methoxy group at δ 54.2 and the mass spectrum showed a molecular ion at m/z 196. These compounds were tested with DHDPS and the results are presented in chapter seven.

6.4 Attempted preparation of thiinanes

Due to the moderate inhibition results obtained with the piperidinedicarboxylic acids, it was decided to synthesise the corresponding six membered ring system with sulfur as the heteroatom. These were to be tested with DHDPS to ascertain their effectiveness as inhibitors.

The first attempted cyclic sulfide, or thiinane was based on the cyclisation of dimethyl 2,6-dibromopimelate (255) using sodium sulfide, see **figure 122**. The dimethyl 2,6-dibromopimelate (255) was prepared by reacting pimelic acid with thionyl chloride and bromine at reflux. The compound was isolated as an oil in 87% yield. The C-2 and C-6 hydrogens were found as a triplet at δ 4.3 in the ^1H NMR spectrum, with a coupling constant of J 7.7 Hz in the ^1H NMR spectrum.

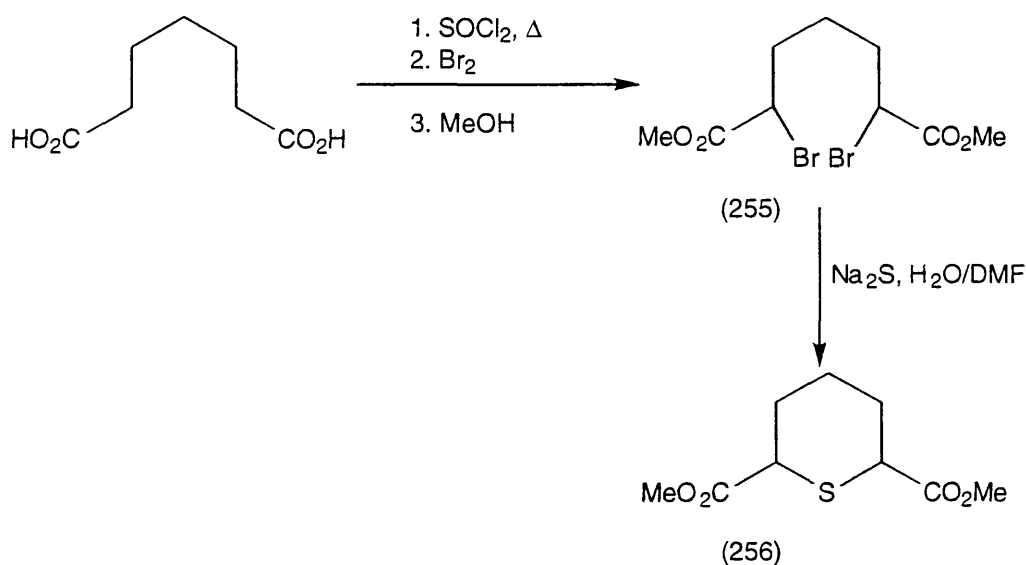


Figure 122: Preparation of (213)

Treatment of (255) with sodium sulfide in DMF gave a 48% yield of the dimethyl thiinane-2,6-dicarboxylate (256) as an oil. The C-2 and C-6 hydrogens were found at δ 4.0 in the ^1H NMR spectrum as a triplet with J 7.7 Hz in the ^1H NMR spectrum. Mass spectrometry gave a molecular ion peak at m/z 218.

The same process was repeated for 4-oxopimelic acid in an attempt to generate the corresponding sulfide with a carbonyl in the 4-position. 4-Oxopimelic acid was treated with thionyl chloride, bromine and methanol in an attempt to produce dimethyl 2,6-dibromo-4-oxopimelate (257), see **figure 123**. The compound recovered from this reaction was shown by ^1H NMR spectrometry not to be compound (257).

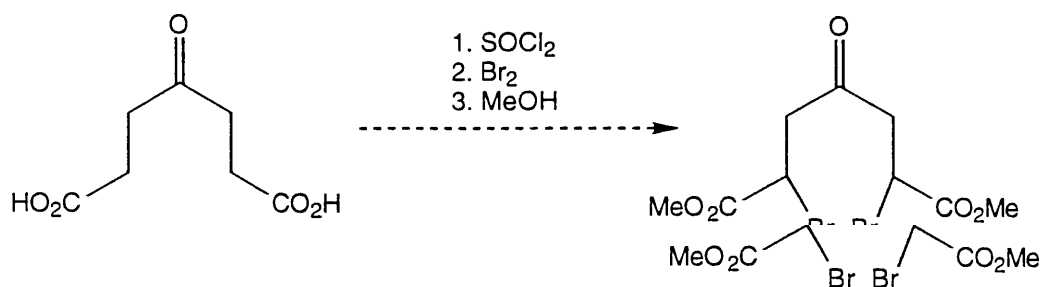


Figure 123: Attempted preparation of dimethyl 2,6-dibromo-4-oxopimelate

6.5 Attempted synthesis of morpholine derivatives

The presence of a hydroxyl group or indeed a heteroatom in the 4-position of the pyridine-2,6- or piperidine-2,6-dicarboxylic acids had been shown to enhance the inhibition of DHDPS (cf. chelidonic and chelidamic acids). The attempted synthesis of substituted morpholines was undertaken to develop inhibitors with an oxygen in the 4-position of the ring system.

The initial target was the morpholine with one ester group in the 2-position (262). This was to be prepared from L-serine methyl ester (258), see **figure 124**. L-Serine methyl ester (258) was treated with *tert*-butyldimethylsilyl chloride and imidazole to produce (259) in 98.5% yield.

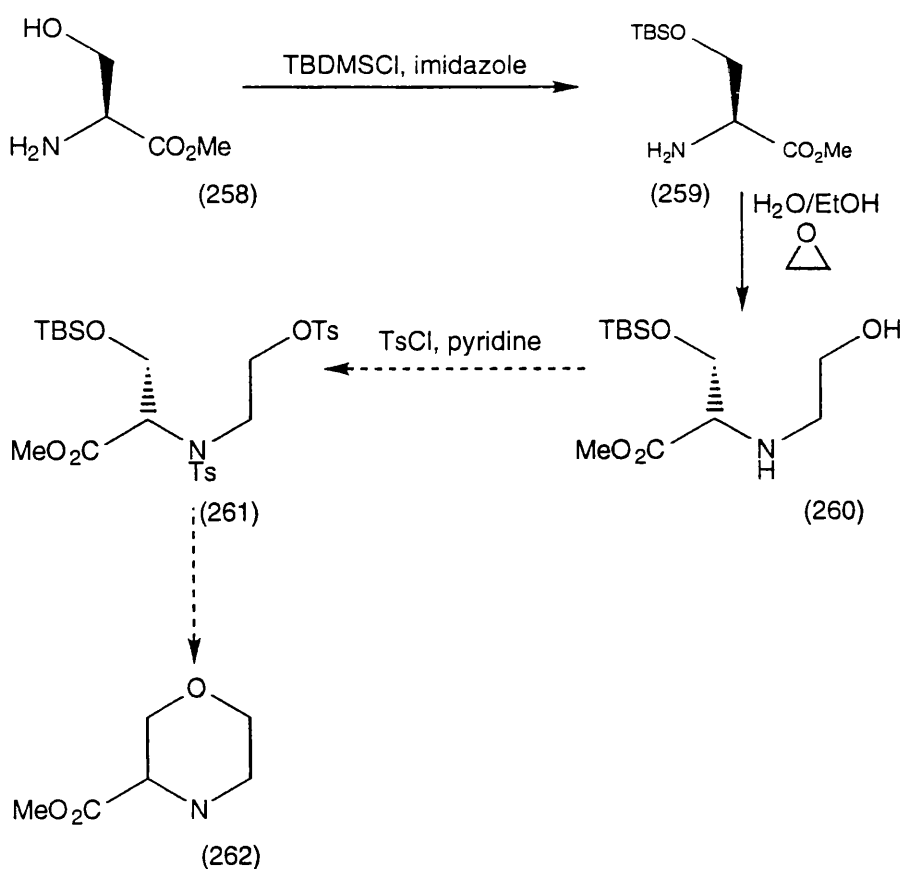
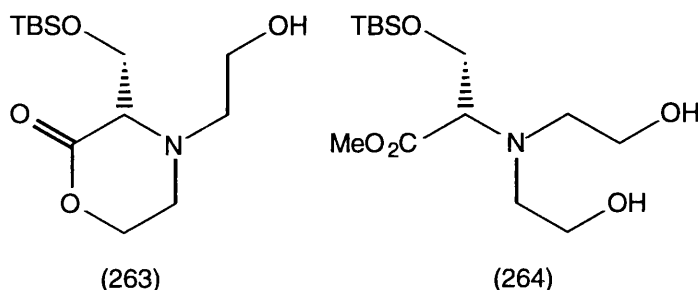


Figure 124: Attempted synthesis of morpholine derivatives

Reaction of (259) with ethylene oxide at 0 °C produced varying yields of the mono-alkylated compound (260). The highest yield that (260) could be isolated in was 85%. The rest of the organic component was made up of di-alkylated compounds such as (263) and (264). These could be isolated after chromatography in yields of up to 25%. Compound (263) was formed by the reaction of the hydroxyl with the methyl ester group to form the lactone. Compound (264) was the result of the amine attacking two molecules of ethylene oxide.



Tosylation of the hydroxyl and nitrogen of compound (260) was carried out using tosyl chloride and pyridine. The material isolated from this reaction showed no sign of the expected product by NMR analysis. It may be that the tosylated nitrogen was still nucleophilic enough to attack the tosylated oxygen to give an aziridine which might react further under the reaction conditions. Protection of the nitrogen before tosylation of the hydroxyl group may allow the isolation of the desired product, this however was not attempted.

6.6 Reduction of Chelidonic acid

Chelidonic (261) and chelidamic acids (as for structure (261) except that the O is replaced with NH) had proved to be very good inhibitors of DHDPS. A fellow co-worker had undertaken some modifications of chelidamic acid, starting off with reduction to the fully saturated compound. These modifications were repeated on chelidonic acid.

The reduction of chelidamic acid had been carried out using 5%-rhodium/alumina catalyst at a pressure of 10 Bar under an atmosphere of hydrogen gas. The reaction took eight hours at 80 °C to reach completion. The isolated compound was a 1:1 mixture of the piperidine compound and the 4-hydroxypiperidine.

Treatment of chelidonic acid (261) with palladium on carbon under a hydrogen atmosphere, reduced the compound to afford a tacky white solid in 50% yield, see **figure 125**. Upon analysis of this solid it was discovered by ^{13}C NMR spectroscopy that there was a mixture of compounds. The two compounds present differed only in their substitution at the 4-position. Compound (262) had a methine signal at δ 66.8 in the ^{13}C NMR spectrum, indicating a hydroxy substituent and compound (263) had a methylene signal for C-4 at δ 23.2 in the ^{13}C NMR spectrum.

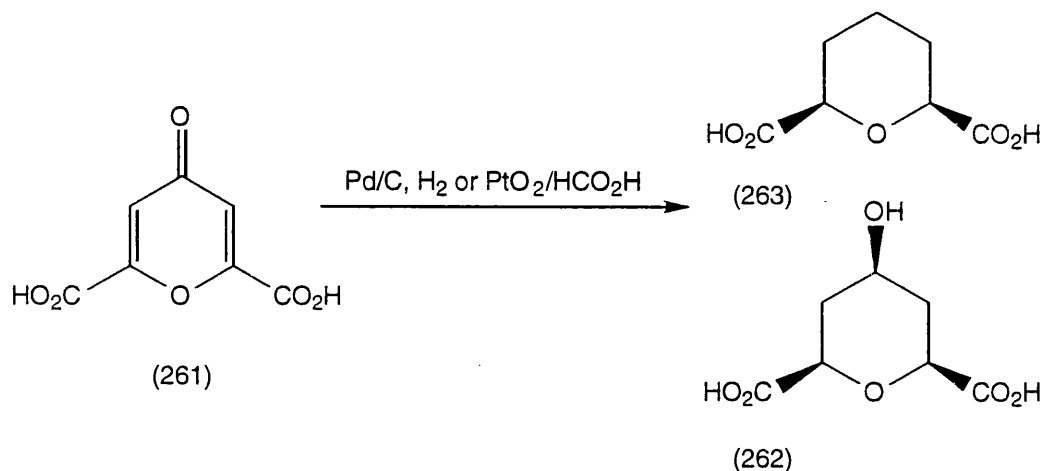


Figure 125: Reduction of chelidonic acid

Reduction using platinum oxide with formic acid as the “hydrogen” source also led to reduction of chelidonic acid. Again, by NMR spectroscopy, the product was identified as a mixture of the 4-hydroxy compound (262) and the tetrahydropyran-2,6-dicarboxylate (263). The ratio of (262) to (263) appeared to be 1:1 by the ^{13}C NMR spectra for both reduction methods.

To aid the separation of the two compounds, the dimethyl esters were made by dissolving compounds (262) and (263) in anhydrous methanol and slowly adding thionyl chloride. The diesters were prepared in 84% yield based on the 1:1 mixture of compounds (262) and (263). Silica gel chromatography enabled the separation of (264) and (265), see **figure 126**.

Compound (264) showed signals at δ 22.7 and 36.9 for the ring CH₂ groups in the ^{13}C NMR spectrum. Mass spectrometry gave a molecular ion for (264) at m/z 202. The corresponding 4-hydroxy compound, after esterification, only made up 15% of the isolated mass. The C-4 signal for (264) was found at δ 66.5 in the ^{13}C NMR spectrum. The CH₂ group was found at δ 36.9. Mass spectrometry gave a peak at m/z 218, which corresponds to the molecular ion of (265).

Test results for the isolated dimethyl esters will be given in the following chapter.

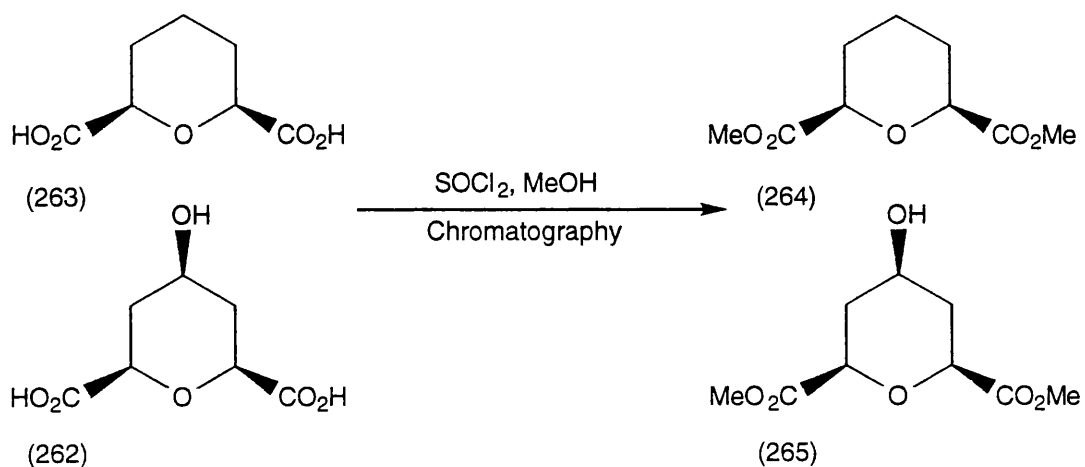


Figure 126: Esterification of reduced chelidonic acid

Chapter Seven: Studies with DHDPS and Biological Results

7.1 Introduction

DHDPS has been extensively studied by many groups over a number of years. A great deal is known about the enzyme's structure and specificity. Our group at Glasgow has been searching for novel inhibitors and substrates for DHDPS for a number of years.

It was discovered early on that DHDPS was very specific for its natural substrates, tolerating very little change in structure or stereochemistry. What we hoped to show is evidence that DHDPS allows several pyruvate analogues to bind to the enzyme, by means of a Schiff's base. We have detected these analogues bound to the enzyme using electrospray mass spectrometry.

Immobilisation of DHDPS using Eupergit resins was also studied to determine if this procedure would confer the stability necessary for multiple experiments using DHDPS. At present we throw away quantities of DHDPS when undertaking any inhibitor studies or biotransformations. It would therefore be ideal to be able to recover and reuse DHDPS time and time again. Immobilisation of enzymes is a standard technique for the generation of recoverable and reusable enzymes.

Eupergit resins are based on polymer supported epoxide groups. It is attack on these groups by nucleophiles, usually free amino groups, on the enzyme that is responsible for the immobilisation. DHDPS is known to have a nucleophile close to the active site which does not interfere with the activity of the enzyme. The presence of this nucleophilic species led us to believe that the immobilisation might be a realistic goal. This chapter will present the initial results concerning the immobilisation of DHDPS on Eupergit resins.

The biological test results for the compounds prepared in the previous chapters will be outlined at the end of the chapter along with some more detailed kinetic analysis of a couple of the better inhibitors. A description of how the testing was carried out and a standard enzyme assay will also be presented.

At Glasgow we have a genetically modified *E. coli* strain which we grow to provide large quantities of DHDPS. DHDPS isolated is used for biochemical testing of potential inhibitors, immobilisation experiments, electrospray mass

spectrometry and for biotransformation studies. To begin this chapter a brief outline of the isolation procedure used to obtain homogeneous samples of DHDPS will be presented.

7.2 Isolation of DHDPS from *E. coli*

DHDPS was isolated from *E. coli* (MV1190/pDA2) grown in MM63 minimal medium supplemented with ampicillin at 30 °C. The purification procedure involves three chromatographic steps before the protein is homogeneous. The purification procedure used was developed by a former co-worker in biochemistry, E. Borthwick.⁶⁶ This procedure was carried out by myself with the aid of Mr. J. Greene of the Universities Biochemistry department.

The cells were grown for 48 hours and were broken open by means of a French press at 95 MPa. The isolated material was subjected to centrifugation to remove any particulate material. A heat step, at 70 °C was used next and removes a number of proteins. The proteins precipitated after the heat step and were removed by centrifugation.

The first chromatographic step uses DEAE-Sephacel (an anion exchanging resin). The crude enzyme mixture was loaded onto the column and eluted with an increasing gradient of potassium chloride (0.1-1.0 M). Fractions of approximately 11 ml were collected and assayed to find the fractions containing DHDPS activity. These fractions were pooled and concentrated using dialysis. Ammonium sulfate was added, to a final concentration of 0.5 M, and the enzyme mixture was loaded onto a phenyl-Sepharose column (hydrophobic interaction). The column was eluted with a decreasing linear gradient of potassium chloride (0.5-0.0 M); again the fractions showing the highest DHDPS activity were pooled and concentrated by dialysis. The final purification step involved chromatography using a Mono-Q FPLC column (HR 10/10) eluting with a two phase gradient of 0.1-0.5 M potassium chloride over twenty minutes. This was followed by elution using a gradient of 0.5-1.0 M over a further forty minutes. Fractions with DHDPS activity were pooled and concentrated using dialysis, and then finally stored in buffer containing 50% glycerol at -20 °C.

The DHDPS recovered from this purification lost no activity when stored at -20 °C for up to six months. A typical purification table is shown below as **table 6**. Depending on the use of the enzyme required, it may be necessary to remove the glycerol from the storage buffer. This is achieved by the use of centrifugation in centricons (membrane filtration devices, designed to retain

proteins but remove molecules below a cut off molecular weight) washing out the glycerol with approximately 4 ml of water.

Step	Protein			Activity (I.U.)	Specific Activity (units/mg)	Yield (%)	Purification (fold)
	Volume (ml)	Conc. (mg/ml)	Total (mg)				
Crude extract	38	31	1180	1240	1.1	100	1.0
Heat step	30	10	300	940	3.1	75	3.0
DEAE-Sephacel	170	0.43	72	2710	38	218	35
Phenyl-Sepharose	192	0.25	48	2110	44	170	42
Mono-Q	35	1.0	35	1820	52	146	49

Table 6: Purification of DHDPS from E. Coli (MV1190/pDA2)

7.3 Electrospray mass spectrometry studies on DHDPS

In chapter two we saw the results of initial studies of DHDPS using electrospray mass spectrometry. It was possible to detect the binding of pyruvate (32) via a Schiff's base to DHDPS. This was seen as a corresponding increase in mass of the detected protein. The mass increase was consistent with one molecule of pyruvate being bound per enzyme molecule, see **figures 19 and 127**. Attempts to show the binding of ASA (23) to DHDPS had produced no evidence for the formation of a Schiff's base between ASA (23) and the enzyme.

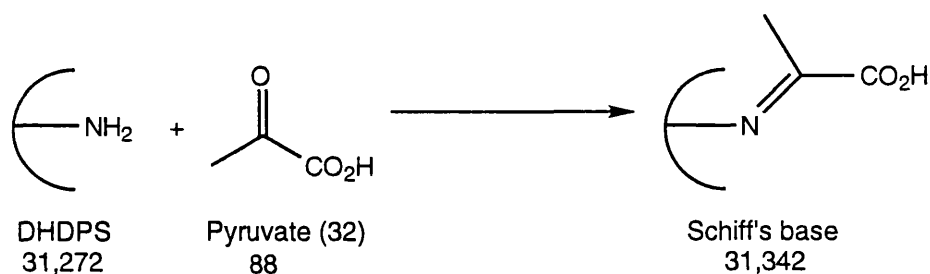


Figure 127: binding of pyruvate (32) to DHDPS

We had hoped to extend this early work on the new electrospray mass spectrometer jointly owned by Glasgow and Strathclyde Universities. Our initial aims were to show the binding of pyruvate and try to obtain evidence for the binding of ASA (23).

We were able to show the binding of pyruvate to DHDPS using the reduced Schiff's base as this is a more reliable technique. Attempts to observe the Schiff's base directly invariably led to the destruction of the enzyme and very messy data from the spectrometer.

Initial studies using the TFA salt of ASA (23) brought no sign of any enzyme with ASA (23) bound. The data obtained were very noisy and the experimental method was not reliable. It was decided to try to detect any ASA (23) bound as a reduced Schiff's base.

A series of experiments were set up using ASA (23) and sodium borohydride to enable the reduction of any Schiff's base adduct formed. The first involved incubation of three concentrations of ASA (23) (2, 4 and 8 mM) with DHDPS and then treatment with sodium borohydride after 20 minutes. Upon electrospray mass spectrometry no sign of any bound ASA (23) could be detected, the only signal present was that for the native enzyme.

The second set of experiments consisted of the addition of pyruvate (32) to the system in case the binding of pyruvate causes a conformational change that allows ASA (23) to bind to DHDPS. The same procedure was repeated with the three concentrations of ASA (23). The electrospray mass spectra of these experiments showed only the reduced Schiff's base with pyruvate.

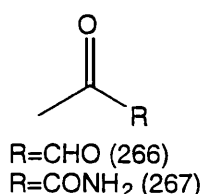
Our last attempts to detect any covalent binding of ASA (23) involved the treatment of DHDPS, with a reduced pyruvate Schiff's base, with ASA (23) at the concentrations used above. Again the only product seen in the spectra was that of DHDPS with a reduced pyruvate Schiff's base. The results obtained using ASA (23) are summarised in **table 7**.

Method of preparation	Concentration of ASA (mM)	Mass expected	Mass obtained
DHDPS	2, 4 and 8	31,371	31,272
DHDPS and pyruvate (16 mM)	2, 4 and 8	31,441	31,342
DHDPS with reduced pyruvate	2, 4 and 8	31,441	31,342

Table 7: Summary of results from electrospray mass spectrometry using ASA (23)

It may be concluded, but not proven, that ASA (23) does not bind via a Schiff's base to DHDPS. If this is indeed the case, it must be held in the active site by some other means, such as electrostatic interactions or hydrogen bonding.

Our search for other substrates of DHDPS led us to try some pyruvate analogues such as pyruvaldehyde (266) and pyruvamide (267) in our electrospray mass spectrometry work.



Both compounds were added to DHDPS and incubated for twenty minutes before the addition of sodium borohydride. The reduced compounds were then taken and run on the electrospray mass spectrometer. Both compounds gave peaks with a corresponding mass increase. The full spectra, including the deconvoluted spectra (shown on the right) for pyruvaldehyde are shown in **figure 128** and the spectra for pyruvamide are shown in **figure 129**. The formation of a Schiff's base between DHDPS and both of these compounds would indicate that they may be substrates for DHDPS. **Figure 130** shows the weights of the adducts formed when the compounds are reduced onto DHDPS. The molecular weights are taken from the deconvoluted spectra at the top right. The spectra recorded for pyruvaldehyde are about twelve amu out but this can be accounted for by partial hydration of the aldehyde. The spectra recorded for the reduced Schiff's base formed when using pyruvamide (267) were found to be within seven amu of the calculated value. Replacing pyruvate with pyruvaldehyde gave rise to an enzymic reaction monitored by uv and shown below in **figure 131**. The rate of reaction was only 2% of that recorded for the natural substrate pyruvic acid (32). A fellow co-worker, Dr. P. Mallon is making a detailed investigation of these results.

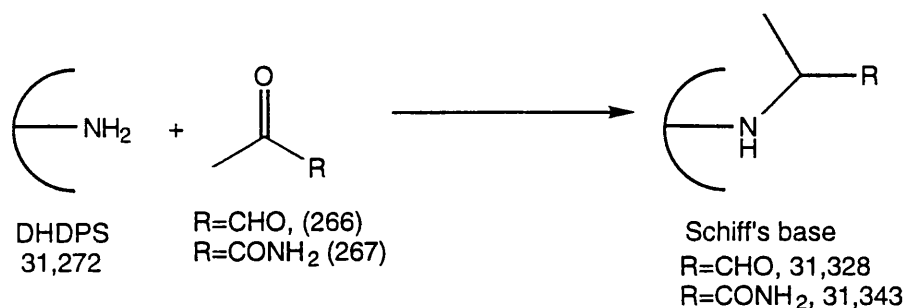


Figure 130: Mass increases expected when the reduced Schiff's bases are detected by electrospray mass spectrometry.

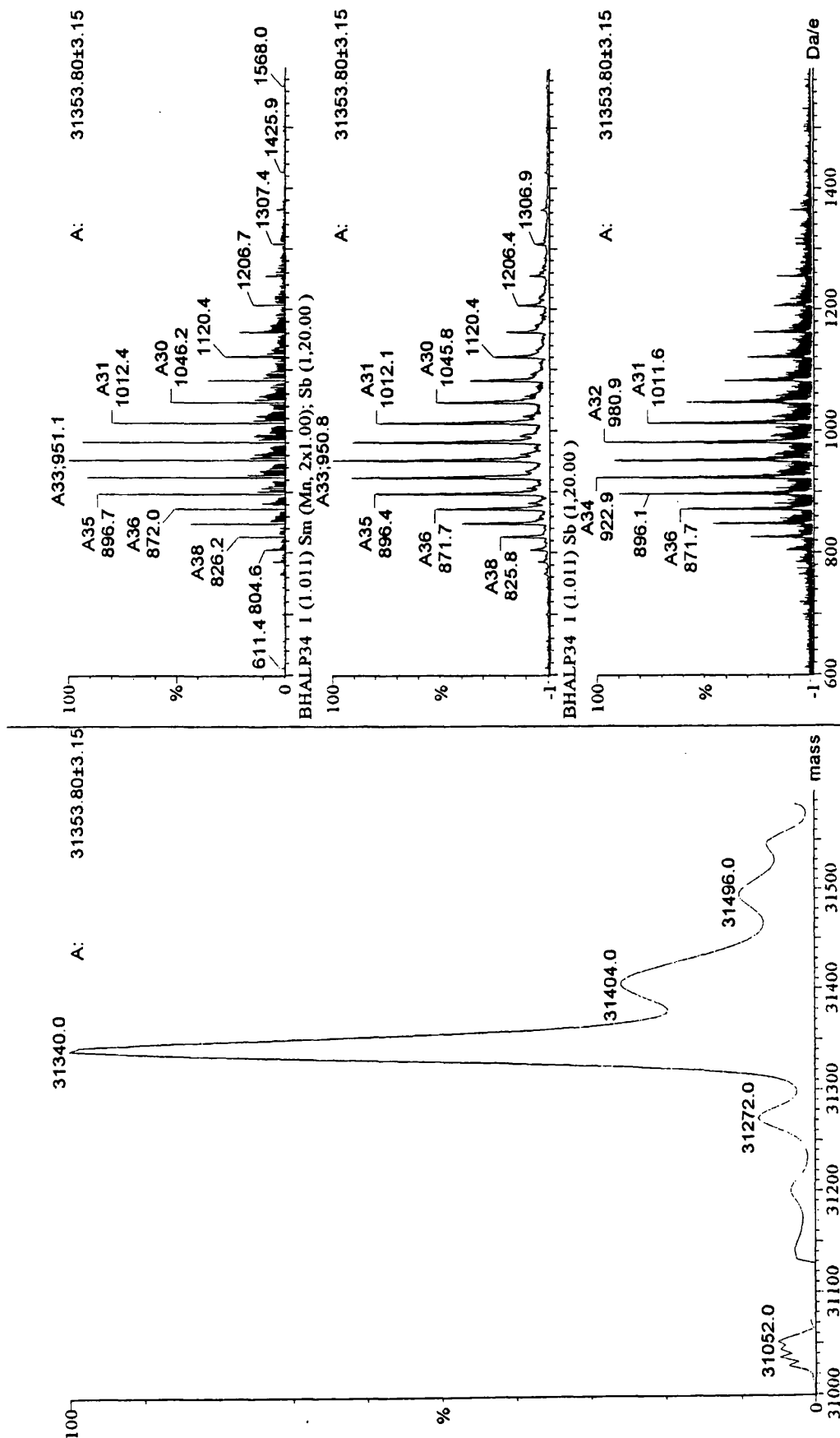


Figure 128: Electrospray mass spectra for pyruvaldehyde with DHDPS (after sodium borohydride treatment)

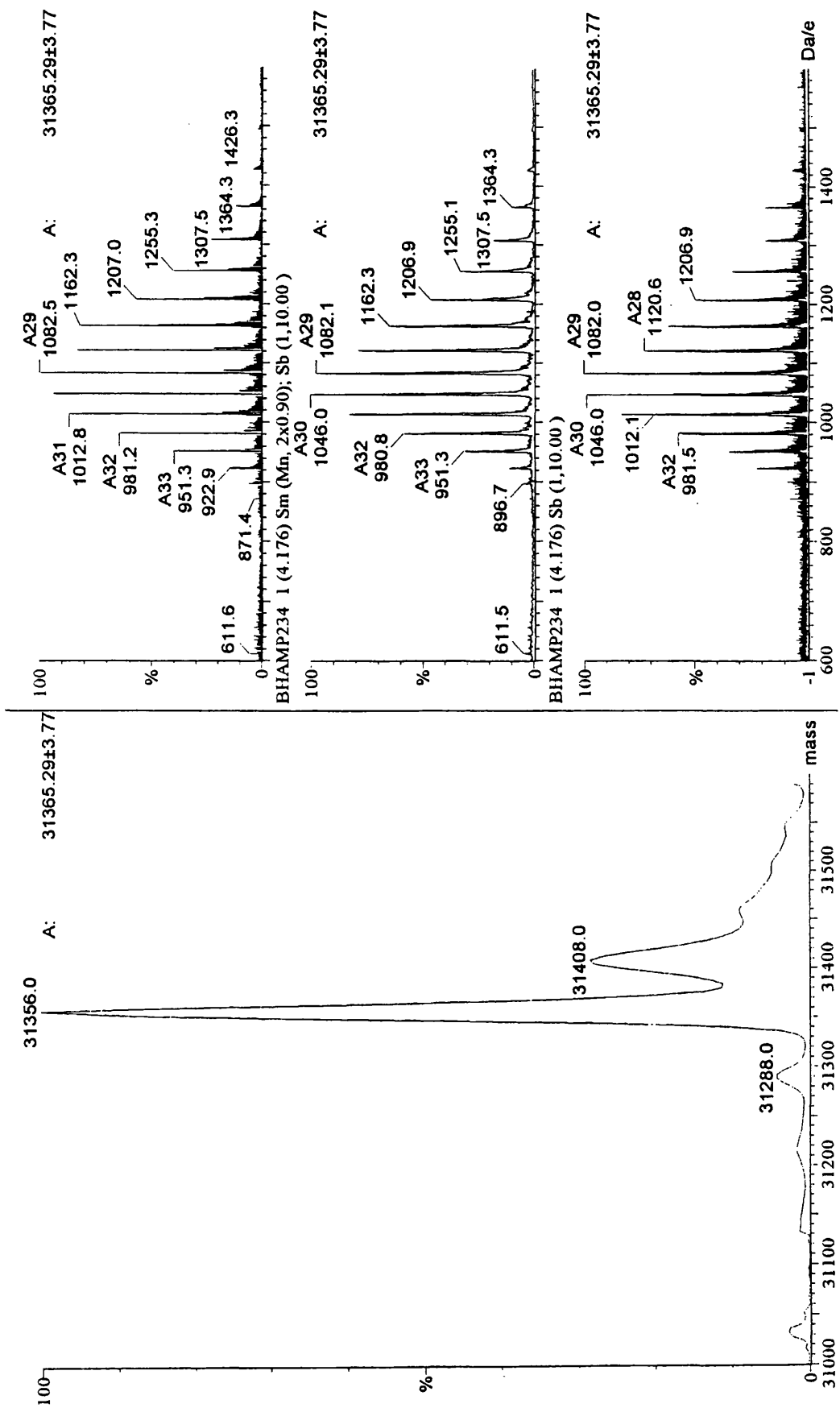


Figure 129: Electrospray mass spectra for pyruvamide with DHDPS (after sodium borohydride treatment)

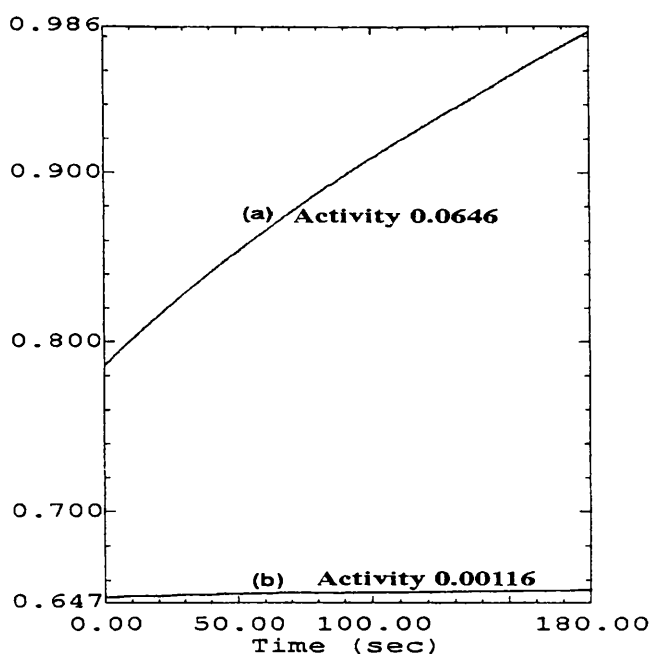


Figure 131: Results of an assay using pyruvaldehyde (266) (b) instead of pyruvate (a)

7.4 Immobilisation of DHDPS on Eupergit resins

The large quantities of DHDPS required for the biological investigations undertaken was more than could be supplied from Biochemistry. We therefore undertook a series of investigations to decide whether DHDPS could be immobilised on a polymer resin to lend long term reusability. The resins that we chose for this study were Eupergit C and C250L. These are polymer resins with epoxide groups at the termini. The immobilisation relies on a nucleophilic species on the enzyme attacking these epoxide groups, see **figure 132**.

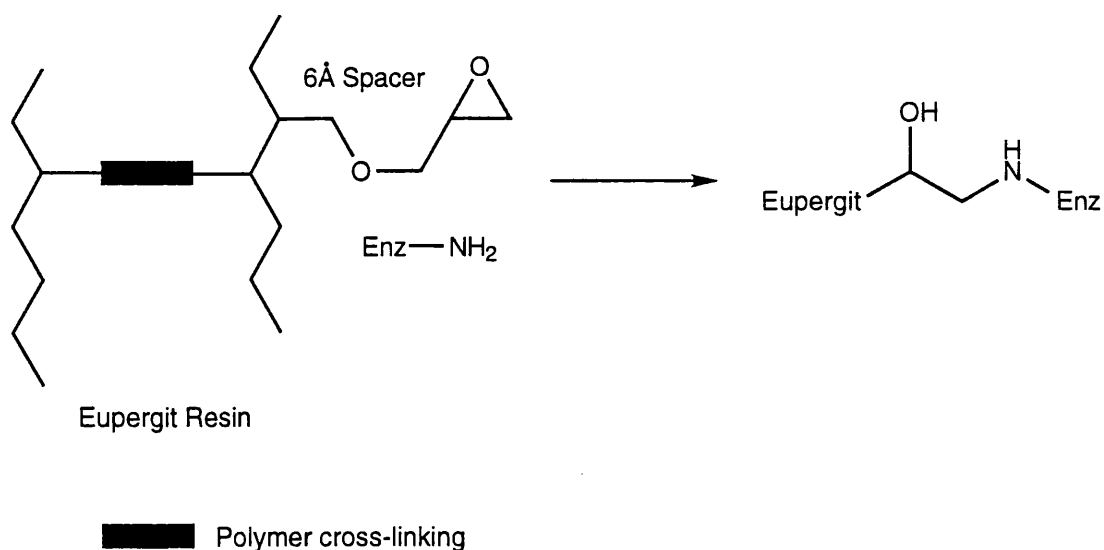


Figure 132: Immobilisation of enzymes using Eupergit resins

Eupergit C and C250L are co-polymers consisting of methacrylamide, allylglycidyl-ether and *N*-methylene-bis-methacrylamide. This produces an electroneutral polymer which is shaped to become spherical. The major difference between Eupergit C and C250L is the average number of epoxide groups per bead. Eupergit C has more than 600 terminal epoxide groups per bead, whereas Eupergit C250L only has, on average, greater than 250 groups per bead.

DHDPS was known to have a nucleophilic species near to the active site (see chapter two) and it was hoped that the enzyme could be immobilised with ease. The immobilisation procedure would take place at any pH between 1 and 12, however it was considered that an enzyme should be immobilised at a pH close to its pH of optimal activity. The other major constraint that was perhaps more damaging to DHDPS, was the need to immobilise at high ionic strength. The procedure called for buffer strengths of approximately 1 M; DHDPS might not retain any activity at such high ionic concentrations.

Initial studies using Eupergit C and following the procedure outlined in the literature supplied with the resins gave no immobilised enzyme. There were a number of probable reasons for this result, including the destruction of DHDPS under the conditions of reaction; multiple alkylation of DHDPS preventing access to the active site; and alkylation at the active site.

A further study was carried out following the literature procedure but adding pyruvate to a final concentration of 5 mM. This produced encouraging results with approximately 10% of the DHDPS being immobilised on the resin.

This result prompted a systematic study of the immobilisation of DHDPS on the resins. It was decided to study the immobilisation in both the potassium phosphate buffer recommended and imidazole (the buffer of choice for the activity assays).

The immobilisation experiments were set up as close to the literature procedure as possible using either 1 M concentrations of potassium phosphate or imidazole as the reaction buffer. An analogous set of experiments was run with the addition of pyruvate to a concentration of 5 mM. The results of these experiments can be seen in **table 8**. Reactions were monitored using a standard assay procedure for DHDPS. Pyruvate and ASA were added to 100 mM imidazole buffer and mixed, 20 mg of the wet beads were then added and

the reaction monitored for one hour, see **figure 133** for the assay recorded using immobilised enzyme obtained from the potassium phosphate experiment.

Eupergit Resin	Buffer	Pyruvate	Final reaction rate (Abs/min)	% immobilised
C	1 M K ₃ PO ₄	Yes	0.000627	10.5
C	1 M K ₃ PO ₄	No	None	0
C 250 L	1 M K ₃ PO ₄	Yes	0.00106	18
C 250 L	1 M K ₃ PO ₄	No	None	0
C	1 M imidazole	Yes	0.000483	8.1
C	1 M imidazole	No	None	0
C 250 L	1 M imidazole	Yes	0.000761	11.5
C 250 L	1 M imidazole	No	None	0

Table 8: Results from immobilisation of DHDPS on Eupergit resins

As the results shown in **table 8** indicate, the immobilisation of DHDPS on Eupergit resins is not an efficient process. The most interesting feature of the table is the fact that pyruvate was required to achieve any functional immobilised enzyme. This might indicate a protective role for pyruvate, where it is bound in the active site and prevents any destructive alkylation. This alkylation might be the result of attack by Lys161 on the epoxide of the Eupergit resins.

Samples of the immobilised material were re-run one week later to determine if there was any significant degradation in activity. The four samples which showed activity in the initial screening were found to give higher reaction rates one week later, see **table 9** below. This effect was reproducible but we can provide no explanation for it. Longer term studies are required to determine how long the enzyme will stay active when bound to the beads.

Sample	Initial Rate (mAbs/min)	Rate at 7 days (mAbs/min)
C (pot. phos.)	0.627 ± 0.0017	0.900 ± 0.0037
C (imidazole)	0.483 ± 0.081	1.140 ± 0.012
C-250L (pot. phos.)	0.761 ± 0.014	0.892 ± 0.0049
C-250L (imidazole)	0.792 ± 0.058	0.713 ± 0.013

Table 9: Assay results from a one week old sample of immobilised DHDPS

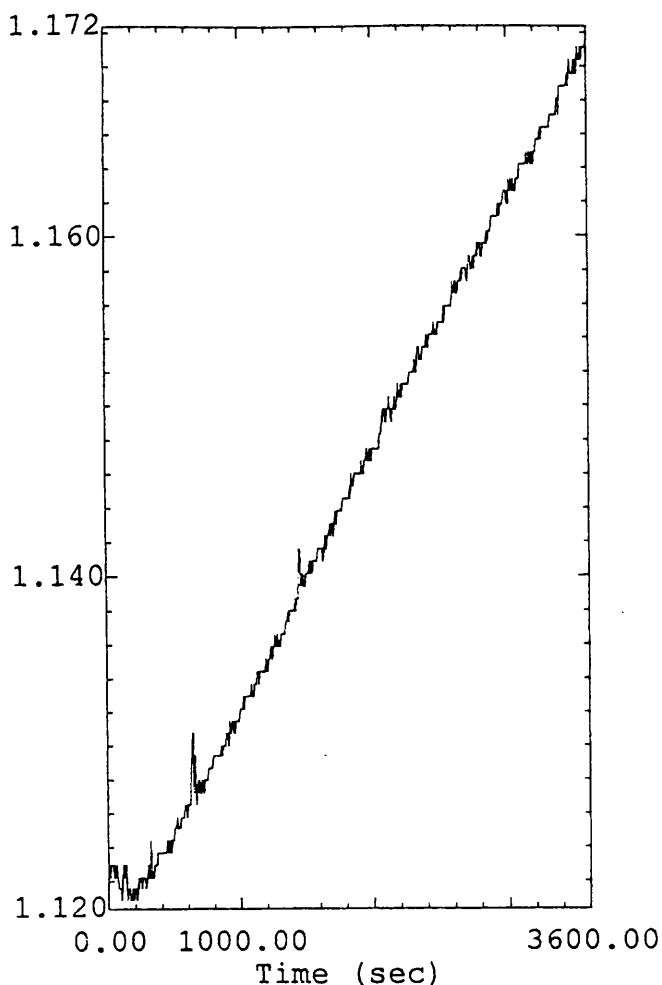


Figure 133: Assay recorded for immobilised DHDPS from potassium phosphate over 1 hour

The low recovery of immobilised material on the Eupergit beads was a disappointment. From these results it may be concluded that the procedure at present is not efficient enough to warrant creating large amounts of immobilised enzyme. A systematic study of the conditions under which the immobilisation of DHDPS is achieved will be required to determine an optimised procedure.

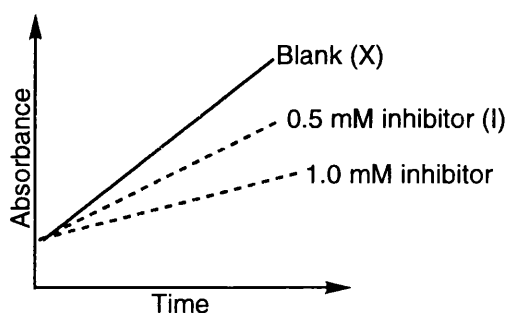
7.5 Test results from inhibition studies with DHDPS

The study of inhibitors of DHDPS was based on the assay system outlined in chapter two (see **figure 15**). We monitored the change in the gradient, observed when an inhibitor is present. This chapter will present the test results for the compounds prepared in the previous chapters.

It was shown that when DHDPS condenses pyruvate (32) and ASA (23) that the diene L-DHDP (27) is produced. If DHDPR is not present, such as in a cell

free assay system using purified DHGPS, the diene (27) is oxidised to produce DPA (33).⁵⁵

We monitored the production of DPA (33) at 270 nm over the course of 3 minutes. The standard assay consisted of a total volume of 1 ml, made up of 150 µl ASA (23), 150 µl pyruvate (32), 500 µl imidazole buffer at pH 7.4, 290 µl of water and 10 µl of DHGPS. When an inhibitor was being studied the quantity of water added was varied to keep the assay at 1 ml. The inhibitors were tested at 1 mM, 0.5 mM and 0.1 mM to obtain a % inhibition at the lowest concentration. The results are an average of three runs. We measured the inhibition as a percentage of a standard rate as shown in **figure 134**. Significant inhibition was taken to be 10% at 0.5 mM.



$$\% \text{ inhibition} = \frac{X-I}{X} \times 100$$

Figure 134: Testing inhibitors of DHGPS

Below are listed the test results obtained for the compounds prepared in chapters three to six. Many of these compounds are racemic and the apparent IC₅₀ values measured are not the true values. The same consideration has to be kept in mind when one considers the results for the amino acid aldehydes produced as these are present mainly as their hydrates. Thus the enzyme may only be recognising the small equilibrium concentration of the aldehyde leading to lower IC₅₀ values.

Chapter three: ASA derivatives

Compound number	Inhibitor Concentration		
	1 mM	0.5 mM	0.1 mM
139	1.5%	0%	-
140	0%	-	-

137	3.5%	0%	-
138	0.25%	-	-
129	12%	0%	-
130	8%	0%	-
148	3%	0%	-
146	9.5%	0%	-
149	0%	-	-
179	8%	1.5%	0%
180	5%	0%	-
181	6.2%	0.5%	0%

None of the ASA derivatives proved to be effective inhibitors of DHDPS at the concentrations tested. Compound (179) was found to be an effective inhibitor at higher concentrations (40% at 5 mM). One of the better inhibition figures was recorded for the *N*-formyl ASA analogue (146) showing 9% at 1 mM. The β -methylated compound (179) was found to be a substrate of DHDPS in place of ASA. The rate recorded was only 15% of that found with ASA. The product of this reaction will need to be isolated and characterised.

Chapter four: Isoxazolines

Compound number	Inhibitor Concentration	
	1 mM	0.5 mM
197	8%	0%
198	12%	1.5%
199	11%	0%
200	5%	0%
201	1.5%	0%
202	3%	0%
203	0%	-
207	0%	-
208	0%	-
212	0%	-
214	7%	0%
215	9%	0%
216	5%	0%

None of the isoxazolines showed better than 12% inhibition at a concentration of 0.5 mM. The ring opened isoxazolines also gave poor figure for inhibition of DHDPS, with none of compounds (175)-1(77) showing any inhibition at concentrations lower than 1 mM.

Chapter five: Glutamic acid γ -semialdehyde analogues

Compound number	Inhibitor Concentration		
	1 mM	0.5 mM	0.1 mM
221	5%	0%	-
228	0%	-	-
239	3%	0%	-
240	15%	1%	0%
242	2.5%	0%	-

As was perhaps expected, the glutamic acid derivatives (221) and (228) were very poor inhibitors of DHDPS with low inhibition values even at very high concentrations. Compound (240) showed the best inhibition values of the group tested. However this is still very poor when compared to the best inhibitors that have been found.

Chapter six: Aromatic analogues and pyruvate derivatives

Compound number	Inhibitor Concentration		
	1 mM	0.5 mM	0.1 mM
247	40%	5%	0%
248	100%	100%	43%
249	0%	-	-
250	0%	-	-
251	0%	-	-
252	0%	-	-
253	100%	59%	27%
254	35%	0%	-
41	100%	60%	25%
42	100%	64%	32%

43	100%	51%	8%
44	100%	68%	31%

All of the aromatic compounds showed good inhibition against DHDPS with the diimidate (42), dinitrile (43), the *N*-oxide (44), the diamide (254), *N*-oxide diester (253) and the ditetrazole (41) being the most potent discovered. The two pyruvate derivatives (247) and (248) also exhibited good inhibition values against DHDPS. The saturated piperidine analogues proved to be poor inhibitors, this may be due to incorrect geometry of the ring. The rest of the compounds also exhibited poor inhibition when tested with DHDPS.

7.6 Determination of the type of inhibition using (43) and (44)

Some detailed kinetic evidence was required to determine how the inhibitors were affecting DHDPS. Pyridine-2,6-dicarboxylic acid *N*-oxide (44) and the pyridine-2,6-dinitrile (43) were used as a representative sample of the aromatic inhibitors. Both were tested with DHDPS to determine the type of inhibition they exhibit.

To determine the type of inhibition it was necessary to keep one of the substrates at a high saturating concentration while the other substrate was varied through a range of values. This procedure was repeated three times with a different concentration of inhibitor present. The procedure was then repeated keeping the second substrate at a high saturating concentration while the other is varied as above.

For our studies on DHDPS this required either pyruvate (32) or ASA (23) to be held at a fixed concentration of 5 mM (about 10 times the K_M value) while the other was varied through a series of decreasing concentrations (from $5xK_M$ down to $0.5xK_M$). The concentrations of inhibitor chosen were 0.04, 0.08 and 0.16 mM.

The data obtained from each run were plotted as a Lineweaver-Burk plot and the line was extrapolated until it cut the X-axis. Once all the lines were plotted and extrapolated the point of intersection of the three lines indicated the type of inhibition (particular to the substrate being varied).

If the lines in the Lineweaver-Burk plots intersect on the Y-axis this is indicative of competitive inhibition of the compound under study with the substrate in question. However, if the lines never meet and remain parallel, this is an

indication that the compound is an un-competitive inhibitor with respect to the substrate in question. Finally if the lines intersect on the X-axis this is taken as an indication that the compound under study is non-competitive with that substrate,^{203,204} see **figure 135**.

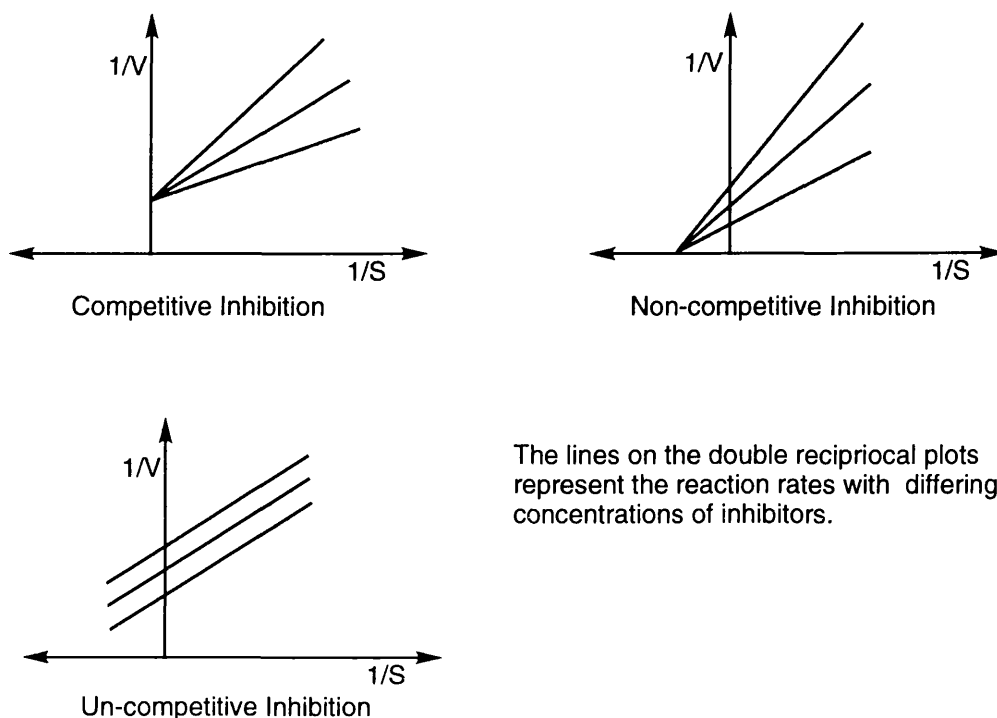


Figure 135: Types of inhibition as visualised by Lineweaver-Burk plots

The data obtained when the study of (43) and (44) was carried out led to the conclusion that both of the aromatic inhibitors were non-competitive inhibitors, see **figure 136** for the Lineweaver-Burk plot for compound (43) obtained when varying the pyruvate concentration (initially plotted by hand and then by computer using Cricket graph III, using the best-fit line function to generate the regression lines). The other plots are similar with the lines intersecting on the X-axis. Both compounds then appear to be non-competitive inhibitors with respect to both substrates. This means that compounds (43) and (44) are competing for a common site in the enzyme with pyruvate and ASA. This is probably the site in which L-DHDP (27) is held until released from the enzyme.

The Lineweaver-Burk plots allowed the determination of K_i values for both of the compounds under investigation. The K_i values for (43) were 0.34 mM against pyruvate (32) and 1.25 mM against ASA (23). The K_i values for (44) were 0.29 mM against ASA (23) and 0.06 mM against pyruvate (32).

Another of the more potent inhibitors that had been found was chelidonic acid (261). Determination of the type of inhibition shown by chelidonic acid (261)

against DHDPS was attempted. The same procedure as above was implemented, but the data obtained were unreliable due to the high absorption of the assay cocktail. The data were however good enough to determine an IC_{50} value of 0.69 mM for chelidonic acid (261). Attempts to improve the data obtained (using smaller path length cuvette or narrowing the slit width on the spectrometer) proved to be useless.

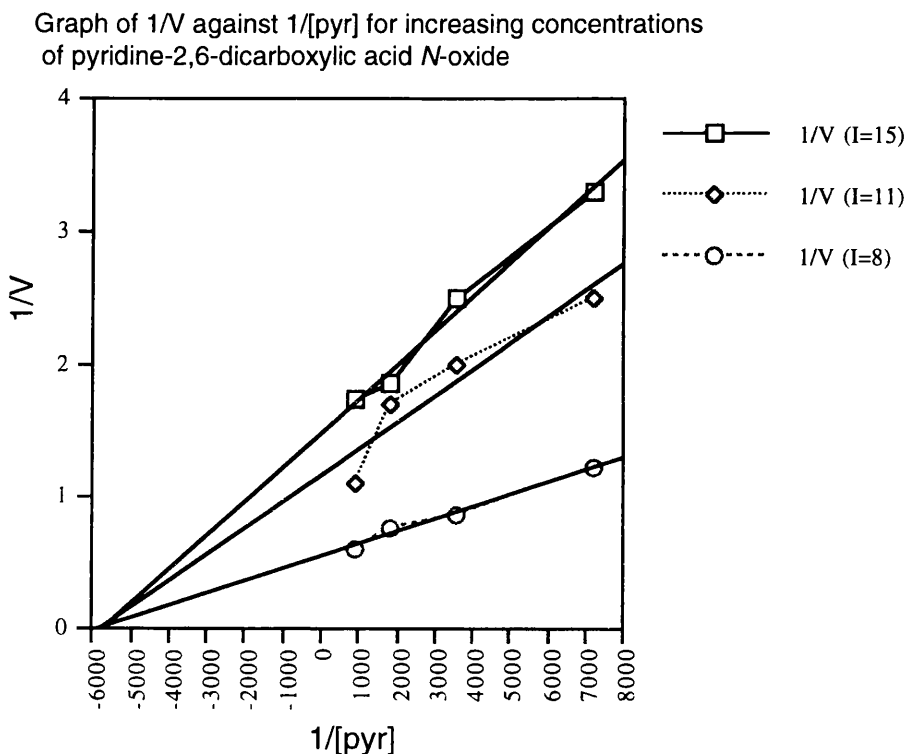


Figure 136: Lineweaver-Burk plot for the inhibition of DHDPS by (43) obtained by the variation of the pyruvate concentration

Chapter Eight: Experimental

8.1: General Notes

All melting points were measured with a Gallenkamp melting point apparatus and are uncorrected. Infra red spectra were recorded on a Philips analytical PU9800 FTIR spectrometer. Nuclear magnetic resonance spectra were recorded on a Perkin-Elmer R32 or a EM390 operating at 90 MHz and then on a Bruker AM200 SY or WP200 SY operating at 200 MHz (δ_{H}) or 50 MHz (δ_{C}) or a Bruker AM360 SY operating at 360 MHz (δ_{H}) or 90 MHz (δ_{C}). Low resolution mass spectra were determined using a VG updated A. E. I. MS spectrometer and high resolution mass spectra were determined using a VG updated MS 902 spectrometer.

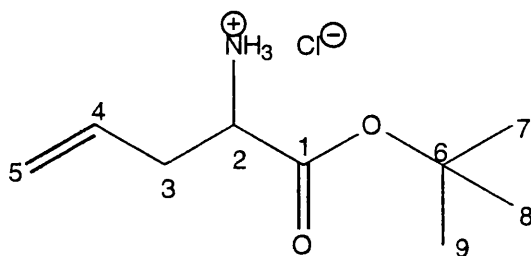
Analytical TLC was carried out using Merck silica gel 60 F₂₅₄ aluminium backed plates of 0.25 mm thickness. Compounds were visualised using UV light or by staining using vanillin solution, with heat development. Column chromatography was carried out using Merck silica gel 60 eluting with ethyl acetate/hexane mixtures unless otherwise stated.

All solvents and reagents were of analytical grade unless otherwise stated. Aqueous solutions were freeze dried using a Christ Alpha 1-4 freeze drier. All organic solvents were dried using standard purification and drying techniques, as detailed in Perrin and Armarego.²⁰⁵

Numbering of compounds is used to aid the identification of peaks in the ¹³C and ¹H NMR spectra.

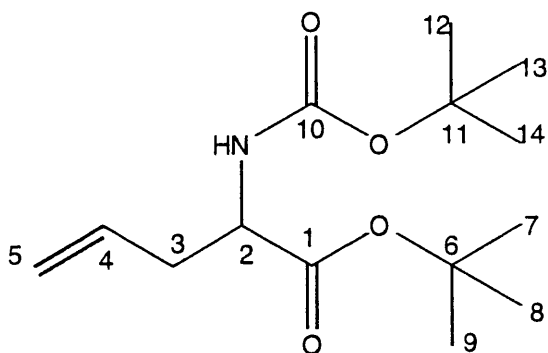
7.2: Experimental Detail for Chapter Three

DL-Allylglycine *t*-Butyl Ester Hydrochloride (124)⁷⁰



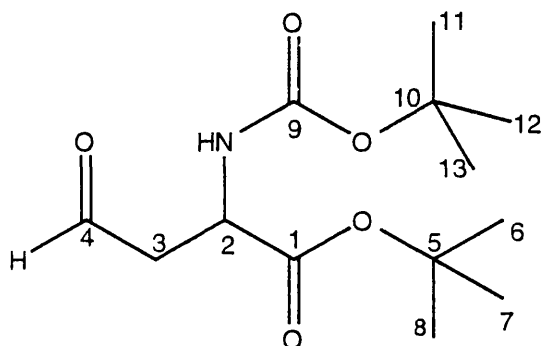
The title compound was prepared using a modified version of the procedure utilised by Tudor *et al.*⁷⁰ To a vigorously stirred suspension of DL-allylglycine (5 g, 43.48 mmol) in dry dichloromethane (100 ml) at -78 °C, was added dropwise via a dry-ice condenser, 2-methylpropene (30 ml). To the suspension was added concentrated sulfuric acid (4 ml). The suspension was then stirred for a further 8 h at -78 °C and then allowed to warm to room temperature overnight. The pH of the resulting clear solution was adjusted to pH 9 using saturated sodium carbonate solution. The organic layer was separated and washed with brine (2 x 50 ml), dried with sodium sulfate, filtered and concentrated *in vacuo* to leave a yellow oil. The oil was then cooled to 0 °C in an ice/water bath. With stirring, ethereal HCl (100 ml) was added and a white solid precipitated. The solid was collected by filtration under vacuum to yield 8.0 g (90% yield); mp 115-117 °C (lit.⁷⁰ 115-117 °C); ν_{\max} (KBr disc) 2980, 2880, 1735, 1570, 1500, cm^{-1} ; δ_{H} (200 MHz) (D_2O) 1.32 (9H, s, 7,8 and 9 H), 2.54 (2H, dd, 3- H_2), 3.94 (1H, dd, 2-H), 5.15 (2H, m, 5- H_2), 5.60 (1H, m, 4-H); δ_{C} (50 MHz) (D_2O) 28.3 (C-7, 8 and 9), 35.4 (C-3), 53.8 (C-2), 86.9 (C-6), 122.7 (C-5), 131.2 (C-4) and 169.6 (C-1); m/z 130, 70 (100%), 57, 43 and 41 (Found M^+ , 172.1338; C, 52.08; H, 8.78; N, 6.73. $\text{C}_9\text{H}_{18}\text{NO}_2$ requires M^+ , 172.1338; C, 52.05; H, 8.78; N, 6.75%).

DL-N-*t*-Butoxycarbonylallylglycine *t*-Butyl Ester (125)⁷⁰



To a stirred solution of (124) (3.0 g, 14.4 mmol) in dioxane/water (1:2, 100 ml) was added sodium bicarbonate (2.42 g, 2 equiv.) and di-*t*-butyldicarbonate (3.3 ml, 1 equiv.). The mixture was stirred at room temperature for 24 h and then the solvent was removed *in vacuo*. The resulting residue was partitioned between ethyl acetate (50 ml) and water (50 ml). The organic layer was separated and the aqueous layer was further extracted with ethyl acetate (2x50 ml). The combined organic extracts were dried (Na₂SO₄), filtered and concentrated *in vacuo* to leave a pale yellow oil, 3.8 g (98% yield); ν_{\max} (CHCl₃) 3425, 2980, 1710, 1495 cm⁻¹; δ_{H} (200 MHz) (CDCl₃) 1.41 (18H, br s, 7-, 8-, 9-, 12-, 13-, 14-H₃), 2.45 (2H, m, 3-H₂), 4.20 (1H, m, 2-H), 5.06 (3H, m, 5-H₂ and NH) and 5.67 (1H, m, 4-H); δ_{C} (50 MHz) (CDCl₃) 27.9 (C-7, 8 and 9), 28.3 (C-12, 13 and 14), 36.8 (C-3), 53.2 (C-2), 79.5 and 81.5 (C-6 and 11), 118.7 (C-5) 132.5 (C-4), 155.1 (C-10) and 171.1 (C-1); *m/z* 230, 170, 130, 114, 70, 57 (100%) and 41 (found: C, 61.95; H, 9.01; N, 5.25. C₁₄H₂₅NO₄ requires C, 61.91; H, 9.21; N, 5.16%).

DL-*N*-*t*-Butoxycarbonylaspartic acid β -semialdehyde *t*-Butyl Ester (126)⁷⁰

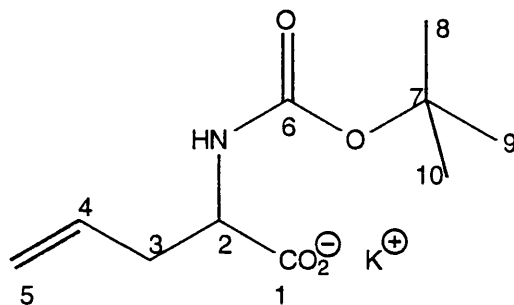


General procedure 1

A solution of compound (125) (1.0 g, 4.82 mmol) in anhydrous dichloromethane (50 ml) was cooled to -78 °C (acetone/dry-ice bath). Ozone was then bubbled through the solution at -78 °C until a blue colour persisted for 30 min. Excess ozone was removed by bubbling nitrogen through the reaction mixture. The ozonide formed during the reaction was decomposed reductively using triethylamine (9.64 mmol) at -78 °C with stirring. The solution was allowed to warm up slowly overnight to room temperature. Dichloromethane was removed under reduced pressure to leave a light yellow oil which was purified using a silica column eluting with ethyl acetate/hexane. This left a pale yellow oil, 0.82 g (74% yield), ν_{\max} (CHCl₃) 3425, 2980, 1710 and 1495 cm⁻¹; δ_{H} (200 MHz) (CDCl₃) 1.44 (18H, br s, 6-, 7-, 8-, 11-, 12- and 13-H₃), 2.98 (2H, m, 3-H₂), 4.48

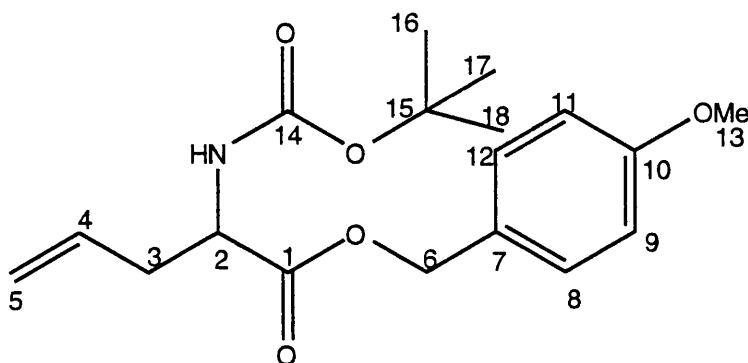
(1H, m, 2-H), 5.40 (1H, br d, NH) and 9.74 (1H, s, 4-H); δ_C (50 MHz) ($CDCl_3$) 27.9 (C-6,7 and 8), 28.3 (C-11, 12 and 13), 36.8 (C-3), 46.3 (C-2), 80.0 and 82.6 (C-5 and -10), 155.3 (C-9), 169.9 (C-1) and 199.4 (C-4); m/z 172, 118, 72, 57 (100%) and 41 (found: C, 56.95; H, 8.32; N, 5.20. $C_{13}H_{23}NO_5$ requires C, 57.07; H, 8.41; N, 5.12%).

Potassium Salt of DL-N-t-Butoxycarbonylallylglycine (127)⁷⁰



To a solution of DL-allylglycine (5.0 g, 43.4 mmol) in water (50 ml) was added dioxan (50 ml), potassium bicarbonate (4.78 g, 1.1 equiv.) and di-*t*-butyl dicarbonate (9.98 ml, 1.0 equiv.). The mixture was stirred at room temperature for 18 h. The solvents were removed under reduced pressure to leave a white solid, 9.11 g (83% yield); ν_{max} (KBr disc) 3360, 2985, 1675, 1590 and 1530 cm^{-1} ; δ_H (200 MHz) (D_2O) 1.27 (9H, s, 9-, 10- and 11- H_3), 2.25 (2H, m, 3- H_2), 2.77 (1H, m, 2-H), 4.98 (2H, m, 5- H_2) and 5.61 (1H, m, 4-H); δ_C (50 MHz) (D_2O) 28.6 (C-8, -9 and -10), 37.3 (C-3), 56.6 (C-2), 81.9 (C-7), 118.9 (C-5), 134.8 (C-4), 166.5 (C-6) and 180.2 (C-1); m/z 214 ($MH^+ - K$, 0.3%), 112, 57 (100%) and 41.

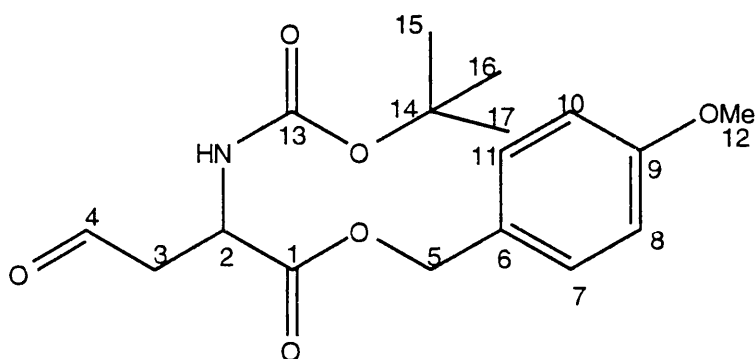
DL-N-t-Butoxycarbonylallylglycine *p*-Methoxybenzyl Ester (128)⁷⁰



To a solution of (127) (8.1 g, 31.9 mmol) in dimethylformamide (DMF) (25 ml) was added 4-methoxybenzyl chloride (4.64 ml, 1.0 equiv.) with continuous stirring for 48 h. DMF was removed with xylene *in vacuo* and the resultant

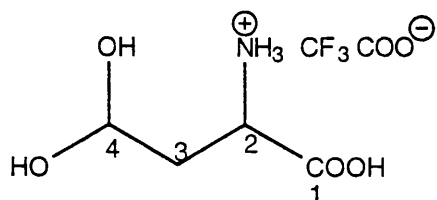
residue was partitioned between dichloromethane (50 ml) and aqueous sodium bicarbonate solution (60 ml). The organic extract was further washed with water (4x50 ml), dried (MgSO₄) and the solvent removed under reduced pressure to leave a yellow oil. Purification on a silica column eluting with ethyl acetate/hexane gave a clear oil, 10.2 g (95% yield); ν_{\max} (CHCl₃) 3440, 3020, 2985, 1720, 1710, 1620, 1515 and 1500 cm⁻¹; δ_{H} (200 MHz) (CDCl₃) 1.43 (9H, s, 16-, 17 and 18-H₃), 2.50 (2H, dd, 3-H₂), 3.79 (3H, s, 13-H₃), 4.39 (1H, m, 2-H), 5.10 (5H, m, 5-H₂ and 6-H₂), 5.67 (1H, m, 4-H), 6.89 (2H, d, *J* 8 Hz, 9- and 11-H), 7.30 (2H, d, *J* 8 Hz, 8- and 12-H); δ_{C} (50 MHz) (CDCl₃) 28.3 (C-16, 17 and 18), 36.7 (C-3), 53.0 (C-2), 55.2 (C-13), 66.9 (C-6), 79.7 (C-15), 113.7 (C-7), 113.9 (C-8 and 12), 119.1 (C-5), 127.4 (C-11), 130.2 (C-9 and 11), 132.2 (C-4), 159.9 (C-14) and 171.9 (C-1); *m/z* 335 (M⁺, 1.0%), 279, 170, 121(100%), 70 and 57 (found : M⁺, 335.1720. C₁₈H₂₅NO₅ requires M⁺, 335.1730).

DL-N-t-Butoxycarbonylaspartic Acid β -semialdehyde *p*-Methoxybenzyl Ester⁷⁰



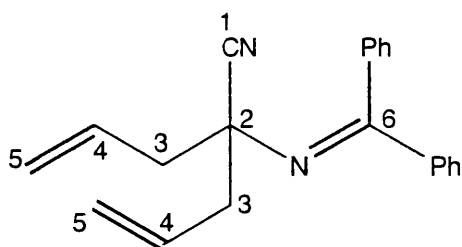
A solution of (128) (9.98 g, 29.75 mmol) was ozonized as per general procedure 1. Triethylamine (2 equiv.) was added and the solution was allowed to warm up to room temperature and was stirred overnight. The solution was then concentrated *in vacuo* and purification was achieved by column chromatography to give a light yellow oil, 9.2g (92% yield); ν_{\max} (CHCl₃) 3430, 3030, 2980, 1735, 1690, 1620 and 1500 cm⁻¹; δ_{H} (200 MHz) (CDCl₃) 3.81 (3H, s, 12-H₃), 4.60 (1H, br m, 2-H), 5.11 (2H, s, 3-H₂), 5.42 (1H, br d, NH), 6.89 (2H, d, *J* 8 Hz, 8 and 10-H), 7.27 (2H, s, *J* 8 Hz, 7 and 11-H) and 9.7 (1H, s, 4-H); δ_{C} (50 MHz) (CDCl₃) 28.2 (C-15, 16 and 17), 46.0 (C-3), 48.8 (C-2), 55.2 (C-12), 67.4 (C-5), 80.2 (C-14), 113.9 (C-7 and 11), 115.1 (C-6), 128.7 (C-9), 130.2 (C-8 and 10), 160.0 (C-13), 171.2 (C-1) and 199.5 (C-4); *m/z* 337 (M⁺, 0.5%), 281, 202, 137, 121 (100%), 72 and 57 (found M⁺, 337.1526. C₁₇H₂₃NO₆ requires M⁺, 337.1519).

Trifluoroacetate salt of DL-Aspartic Acid β -Semialdehyde Hydrate (23)⁷⁰



A solution of (126) (750 mg, 2.22 mmol) in trifluoroacetic acid (4 ml) and anhydrous dichloromethane (5 ml) was prepared in a flame dried flask under a dry nitrogen atmosphere. This was stirred at 0 °C for 2 h. The solvent was then removed *in vacuo* to give an oily residue. This was partitioned between ethyl acetate (5 ml) and water (5 ml). The water layer was further washed with ethyl acetate (3 x 5 ml). Removal of the water *in vacuo* gave a yellow solid, 264 mg (48% yield), mp 63-65 °C (lit.⁷⁰ 63-65 °C); ν_{\max} (KBr disc) 3420 (broad), 2925, 1675 and 1645 cm⁻¹; δ_{H} (200 MHz) (D₂O) 1.98 (2H, m, 3-H₂), 3.82 (1H, dd, 2H) and 5.10 (1H, t, 4-H); δ_{C} (50 MHz) (D₂O) 37.8 (C-3), 51.9 (C-2), 89.2 (C-4) and 173.9 (C-1).; m/z (MH⁺, 137.0445. C₄H₁₁NO₄ requires MH⁺ 137.0450).

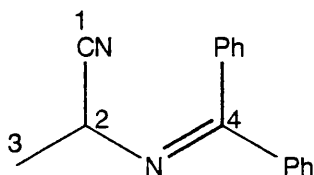
N-(Diphenylmethylene)-2-amino-2-(2-propenyl)-4-Pentenitrile (132)



To a vigorously stirred bi-phasic mixture of N-(diphenylmethylene)aminoacetonitrile (5.0 g, 22.73 mmol.), benzyltriethylammonium chloride (0.5 g), 50% aqueous sodium hydroxide solution (20 ml) and toluene (15 ml) at 0 °C was added dropwise, via a syringe pump, allyl bromide (4.12 g, 1.5 equiv.). The reaction turned a deep red/black colour. The reaction was stirred at 0 °C for a further 1 h and was then allowed to warm up to room temperature overnight. The reaction mixture was poured into dichloromethane (50 ml) and the organic layer was separated and kept. The aqueous layer was extracted with dichloromethane (2x30 ml) and combined with the previous organic extracts. The organic extracts were dried (Na₂SO₄), filtered and concentrated *in vacuo* to leave a yellow oil, which when purified (silica gel column) gave a clear oil, which solidified with time, 4.4 g (65% yield); ν_{\max} (CHCl₃) 3050, 2257, 1637 and

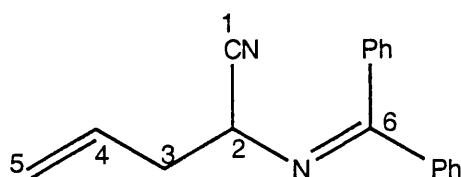
1607; δ_{H} (200 MHz) (CDCl_3) 2.7 (4H, 3-H₂), 5.2 (4H, m, 5-H₂), 5.7-6.0 (2H, m, 4-H) and 7.1-7.6 (10H, m, aromatic protons); δ_{C} (50 MHz) (CDCl_3) 45.9 (C-3), 61.7 (C-2), 119.1 (C-1), 120.3 (C-5), 128.6 (C-4), 168.2 (C-6) and 128.0, 128.2, 129.4, 129.6, 130.6, 131.7, 135.2 and 139.9 (aromatic carbons); m/z 300 (M^+ , 11.8%), 259, 233, 217, 192, 165, 130, 104 and 77 (100%) (found: M^+ , 300.3960. $\text{C}_{21}\text{H}_{20}\text{N}_2$ requires M^+ , 300.3955).

N-(Diphenylmethylene)-2-amino-propanoitrile (133)



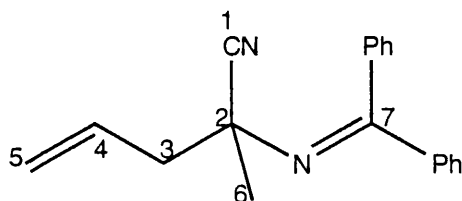
To a vigorously stirred bi-phasic mixture of *N*-(diphenylmethylene)aminoacetonitrile (5.0 g, 22.73 mmol.), benzyltriethylammonium chloride (0.5 g), 50% aqueous sodium hydroxide solution (20 ml) and toluene (15 ml) at 0 °C was added dropwise, via a syringe pump, iodomethane (4.84 g, 1.5 equiv.). The reaction turned a deep red/black colour instantaneously. The reaction was stirred at 0 °C for a further 1 h then allowed to warm up to room temperature overnight. The reaction mixture was then poured into dichloromethane (50 ml) and the organic layer was separated. The aqueous layer was extracted with dichloromethane (2x30 ml) and combined with the previous organic extracts. The organic extracts were dried (Na_2SO_4), filtered and concentrated *in vacuo* to leave a yellow oil, which when purified (silica gel column) gave a yellow oil, 4.8 g (90% yield); ν_{max} 3020, 2930, 2230, 1610 and 1500 (CHCl_3) cm^{-1} ; δ_{H} (200 MHz) (CDCl_3) 1.5 (3H, d, J 6.7 Hz, 3-H₃), 4.4-4.5 (1H, q, J 6.7 Hz, 2-H), 7.1-7.8 (10H, m, aromatic protons); δ_{C} (50 MHz) (CDCl_3) 21.0 (C-3), 48.2 (C-2), 120.4 (C-1), 127.3, 128.2, 128.69, 128.9, 129.4, 129.7, 130.1 (aromatic carbons), 172.3 (C-4); m/z 234 (M^+ , 31.8%), 218, 207, 180, 165, 105, 77 (100%) and 51 (found: M^+ , 234.2950. $\text{C}_{16}\text{H}_{14}\text{N}_2$ requires M^+ , 234.2954).

N-(Diphenylmethylene)-2-amino-4-pentenitrile (131)



To a vigorously stirred bi-phasic mixture of *N*-(diphenylmethylene)aminoacetonitrile (5.0 g, 22.73 mmol.), benzyltriethylammonium chloride (0.5 g), 25% aqueous sodium hydroxide solution (20 ml) and toluene (15 ml) at 0 °C was added dropwise, via a syringe pump, allyl bromide (4.12 g, 1.5 equiv.). The reaction turned a deep red/black colour. The reaction was stirred at 0 °C for a further 1 h and then allowed to warm up to room temperature overnight. The reaction mixture was then poured into dichloromethane (50 ml) and the organic layer was separated. The aqueous layer was extracted with dichloromethane (2x30 ml) and combined with the previous organic extracts. The organic extracts were dried (Na₂SO₄), filtered and concentrated *in vacuo* to leave a yellow oil, which when purified (silica gel column) gave a clear yellowish oil, 5.4 g (91.4% yield); ν_{\max} 3080, 3015, 2235, 1605 and 1515 (CHCl₃); δ_{H} (200 MHz) (CDCl₃) 2.5-2.7 (2H, m, 3-H₂), 4.3 (1H, t, *J* 6.75 Hz, 2-H), 5.1-5.3 (2H, m, 5-H₂), 5.6-5.9 (1H, m, 4-H), 7.1-7.8 (10H, m, aromatic protons); δ_{C} (50 MHz) (CDCl₃) 39.1 (C-3), 53.0 (C-2), 119.2 (C-1), 119.6 (C-5), 129 (C-4), 125.2, 127.4, 128.2, 129.4, 131.2, 131.9, 135.1 and 138.3 (aromatic carbons), 173.1 (C-6); *m/z* 260 (M⁺, 8.4%), 219, 165, 116 (100%) and 77 (found: M⁺, 260.1303. C₁₈H₁₆N₂ requires M⁺, 260.1310).

N-(Diphenylmethylene)-2-amino-2-methyl-4-pentenitrile (135)



Method 1

To a solution of (131) (1g, 3.85 mmol.) in acetonitrile (15 ml) was added finely powdered potassium hydroxide (1.05 equiv.). The suspension was stirred vigorously and cooled to 0 °C before iodomethane was added dropwise, via a syringe pump, over 1 h. The reaction was allowed to warm up to room temperature over a period of 3 h. Addition of water (25 ml) and ethyl acetate (25 ml) was followed by separation of the organic layer and further extraction of the aqueous layer with ethyl acetate (2x25 ml). The organic layers were combined, dried (MgSO₄), filtered and concentrated *in vacuo* to leave a pale yellow oil, 950 mg (89.5% yield) which was starting material by ¹H NMR spectroscopy.

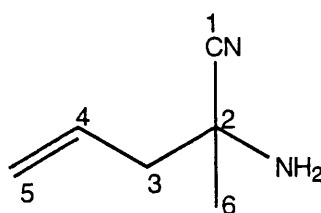
Method 2

To a flame dried flask, under a dry nitrogen atmosphere, was added diisopropylamine (0.8 g, 2.1 equiv.) in anhydrous tetrahydrofuran (10 ml). This solution was cooled to -20 °C (acetone/dry ice bath) and butyllithium (0.51 g, 2.1 equiv.) was added dropwise over a period of 10 min. The solution was stirred at -20 °C for a further 20 min before being cooled to -78 °C and (131) (1.0 g, 3.85 mmol) was added dropwise over 15 min. The solution was stirred for a further 30 min before iodomethane (1.15 g, 2.1 equiv.) was added to quench the anion. The mixture was allowed to warm up to room temp over a period of 1 h, and then poured into a saturated solution of ammonium chloride and then diluted with ether (40 ml). The organic layer was separated and the aqueous layer was extracted with ether (2x30 ml). The combined organic extracts were dried (MgSO₄), filtered and concentrated *in vacuo*. The remaining yellow oil was purified by column chromatography, to leave a pale yellow oil, 0.90 g (85% yield); ν_{max} 3090, 2950, 2230, 1595 and 1510 (CHCl₃); δ_{H} (200 MHz) (CDCl₃) 1.64 (3H, s, 6-H₃), 2.57-2.83 (2H, m, 3-H₂), 5.20-5.29 (2H, m, 5-H₂), 5.81-6.02 (1H, m, 5-H) and 7.14-7.61 (10H, m, aromatic protons); δ_{C} (50 MHz) (CDCl₃) 28.4 (C-6), 48.4 (C-3), 57.3 (C-2), 120.11 (C-1), 120.16 (C-5), 128.1 (C-4), 128.4, 128.5, 129.5, 130.6, 132.2, 135.2, 139.9 (aromatic carbons) and 168.3 (C-7); m/z 274 (M⁺, 10.7%), 233, 180, 165, 130 (100%), 103 and 77 (found: M⁺, 274.1476. C₁₉H₁₈N₂ requires M⁺ 274.1466).

Method 3

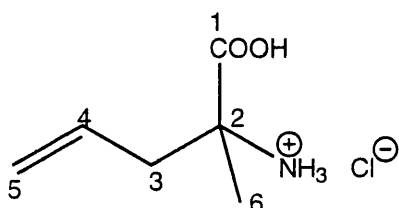
The procedure above could be used to generate compound (135), starting from compound (133). The reaction was carried out using allyl bromide as the electrophile, and the product was isolated as an oil. The isolated yellow oil was purified by column chromatography, to leave a pale yellow oil, 0.9 g (77% yield); analysis as above.

2-Amino-2-methyl-4-pentenitrile (139)



To a mixture of 2M HCl (10 ml) and ether (15 ml) was added (135) (1.0 g, 3.65 mmol). The solution was stirred vigorously for 2 h before the organic layer was separated and discarded. The aqueous layer was then adjusted to pH 9 with saturated sodium carbonate solution. The aqueous layer was extracted with ethyl acetate (2x25 ml). The combined organic extracts were dried (MgSO₄), filtered and concentrated *in vacuo* to leave a yellow oil 0.3 g (75% yield); ν_{\max} (CHCl₃) 3080, 2920 and 2240 cm⁻¹; δ_{H} (200 MHz) (CDCl₃) 1.69 (3H, s, 6-H₃), 2.6-3.0 (2H, m, 3-H₂), 5.4 (2H, m, 5-H₂), 5.8-6.0 (1H, m, 4-H); δ_{C} (50 MHz) (CDCl₃) 22.67 (C-6), 41.9 (C-3), 61.1 (C-2), 122.2 (C-1), 123.9 (C-5) and 130.6 (C-4); m/z 110 (M⁺, 14.5%), 95, 84, 69 (100%), 55 and 41 (found: M⁺, 110.0845. C₆H₁₀N₂ requires M⁺, 110.0842).

2-Amino-2-methyl-4-pentenoic Acid Hydrochloride (137)

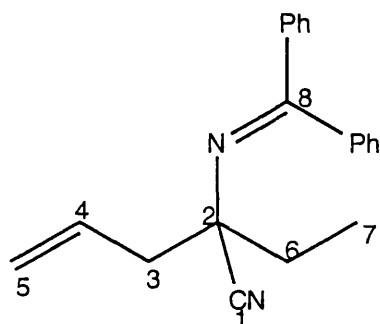


The aminonitrile (139) (713 mg, 6.48 mmol) was stirred in a solution of 4M sodium hydroxide (15 ml) at reflux for 18 h. The solution was allowed to cool to room temperature and was washed with ethyl acetate (15 ml) to remove any organic contaminant. The solution was then acidified to pH 1 using 2M HCl solution. The aqueous layer was again washed with ethyl acetate (15 ml) and was then partially concentrated *in vacuo* to leave approximately 2 ml of suspended amino acid. The amino acid suspension was then freeze dried overnight to leave a white solid which contained the amino acid and contaminating sodium chloride; ν_{\max} (KBr disc) 3430, 2990, 2500, 1734, 1636 cm⁻¹; δ_{H} (200 MHz) (D₂O) 2.15 (3H, s, 6-H₃), 2.3-2.6 (2H, m, 3-H₂), 5.1-5.2 (2H, m, 5-H₂) and 5.6-5.8 (1H, m, 4-H); δ_{C} (50 MHz) (D₂O) 22.8 (C-6), 42.2 (C-3), 61.9 (C-2), 122.7 (C-5), 131.2 (C-4) and 175.0 (C-1), m/z 129 (M⁺, 0.8%), 114, 88, 68 and 42 (100%) (found: M⁺, 129.0771. C₆H₁₁NO₂ requires 129.0787).

N-(Diphenylmethylene)-2-amino-2-ethyl-4-pentenitrile (136)

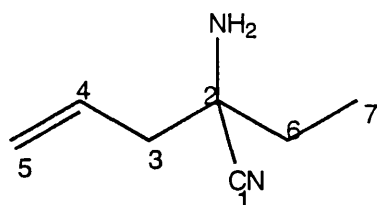
To a flame dried flask, under a dry nitrogen atmosphere, was added diisopropylamine (0.80 g, 2.1 equiv.) in anhydrous tetrahydrofuran (10 ml). This solution was cooled to -20 °C (acetone/dry ice bath) and butyllithium (0.51 g, 2.1 equiv.) was added dropwise over a period of 10 min. The solution was

stirred at -20 C for a further 20 min before being cooled to -78 C and (131) (1.0 g, 3.85 mmol) was added dropwise over 15 min. The solution was then stirred for a further 30 min before ethyl iodide (0.90 g, 1.5 equiv.) was added to quench the anion. After allowing the solution to warm to room temp over a period of 1 h, the contents of the flask were poured into a saturated solution of ammonium chloride and diluted with ether (40 ml). The organic layer was separated and the aqueous layer was extracted with ether (2x30 ml). The combined organic extracts were dried (MgSO₄), filtered and concentrated *in vacuo*. The remaining yellow oil was purified by column chromatography, to leave a pale yellow oil, 0.98 g (88.5% yield);



ν_{\max} (CHCl₃) 3065, 2253, 1610 and 1506 cm⁻¹; δ_{H} (200 MHz) (CDCl₃) 1.0 (3H, t, *J* 7.4 Hz, 7-H₃), 1.90-2.15 (2H, m, 6-H₂), 2.59-2.78 (2H, m, 3-H₂), 5.17-5.26 (2H, m, 5-H₂), 5.77-5.98 (1H, m, 4-H) and 7.19-7.61 (10H, m, aromatic protons); δ_{C} (50 MHz) (CDCl₃) 9.13 (C-7), 35.0 (C-6), 46.0 (C-3), 62.3 (C-2), 119.4 (C-1), 120.1 (C-5), 127.4-139.9 (C-4 and aromatic carbons) and 168.0 (C-8); *m/z* 288 (M⁺, 10.4%), 261, 247 (100%), 219, 165, 144, 116, 91 and 77 (found M⁺, 288.1620. C₂₀H₂₀N₂ requires M⁺, 288.1622).

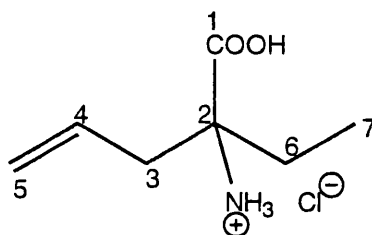
2-Amino-2-ethyl-4-pentenitrile (140)



To a mixture of 2M HCl (10 ml) and ether (15 ml) was added (136) (1.0 g, 3.47 mmol). The solution was stirred vigorously for 2 h before the organic layer was separated and discarded. The aqueous layer was then adjusted to pH 9 with saturated sodium carbonate solution. The aqueous layer was extracted with ethyl acetate (2x25 ml). The combined organic extracts were dried (MgSO₄), filtered and concentrated *in vacuo* to leave, after chromatography, an orange oil

0.367 g (85% yield); δ_{H} (200 MHz) (CDCl_3) 1.1 (3H, t, J 7.4 Hz, 7- H_3), 1.5-1.8 (2H, m, J 7.3 Hz, 6- H_2), 2.2-2.6 (2H, m, 3- H_2), 5.2-5.4 (2H, m, 5- H_2) and 5.8-6.0 (1H, m, 4-H); δ_{C} (50 MHz) (CDCl_3) 8.4 (C-7), 33.1 (C-6), 43.8 (C-3), 53.5 (C-2), 121.3 (C-5), 123.1 (C-1) and 131.2 (C-4); m/z 124 (M^+ , 2.4%), 98, 97, 84 (100%), 68 and 41 (found: M^+ , 124.1009. $\text{C}_7\text{H}_{12}\text{N}_2$ requires M^+ , 124.0998).

2-Amino-2-ethyl-4-pentenoic Acid (138)

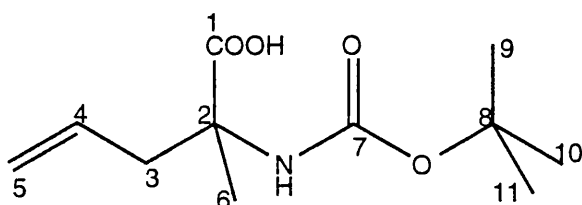


The aminonitrile (140) (720 mg, 5.81 mmol) was heated and stirred in a solution of 4M sodium hydroxide (15 ml) at reflux for 18 h. The solution was allowed to cool to room temperature and was washed with ethyl acetate (15 ml) to remove any organic contaminant. The solution was then acidified to pH 1 using 2M HCl solution. The aqueous layer was washed with ethyl acetate (15 ml) and was then partially concentrated *in vacuo* to leave approximately 2 ml of suspended amino acid. The amino acid suspension was then freeze dried overnight to leave a white solid which contained the amino acid and contaminating sodium chloride; ν_{max} (KBr disc) 3400, 3010, 2530, 1705, 1625 cm^{-1} ; δ_{H} (200 MHz) (D_2O) 0.75 (3H, t, J 7.6 Hz, 7 H_3), 1.6-1.9 (2H, m, 6 H_2), 2.3-2.6 (2H, m, 3 H_2), 5.0-5.2 (2H, m, 5 H_2) and 5.4-5.7 (1H, m, 4H); δ_{C} (50 MHz) (D_2O) 8.3 (C-7), 29.5 (C-6), 40.5 (C-3), 65.0 (C-2), 123.4 (C-5), 130.5 (C-4) and 174.5 (C-1); m/z 143 (M^+ , 0.7%), 114, 102, 99 and 42 (100%) (found: M^+ , 134.1810. $\text{C}_7\text{H}_{13}\text{NO}_2$ requires M^+ , 134.1798).

Attempted Preparation of *N*-t-Butoxycarbonyl-2-amino-2-methyl-4-pentenoic Acid

Method 1

To a solution of (137) (1.0 g, 5.57 mmol) in water (50 ml) was added dioxan (50 ml), potassium bicarbonate (612 mg, 1.1 equiv.) and di-*t*-butyl dicarbonate (1.3 g, 1.1 equiv.). The mixture was stirred at room temperature for 18 h. The solvents were removed under reduced pressure to leave a white solid. Upon analysis the solid proved to be starting material.



Method 2

To a solution of (137) (250 mg, 1.51 mmol) in dioxan/water (1:1, 30 ml) was added triethylamine (229 mg, 1.5 equiv.) with continuous stirring at room temperature. Addition of BOC-ON (409 mg, 1.1 equiv.) was carried out slowly over 5 min. The solution was stirred overnight at room temperature. Water (10 ml) was added and the mixture was washed with ethyl acetate (2x20 ml). The aqueous layer was then concentrated *in vacuo* until the volume was approximately 1 ml and it was then transferred to a freeze drier. A white solid was isolated from the freeze drier which upon analysis proved to be starting material.

Method 3

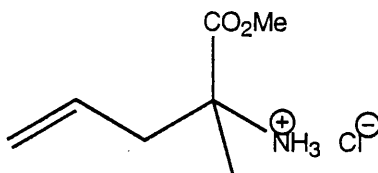
To a solution of (137) (1.0 g, 6.0 mmol) in dry acetonitrile (10 ml) was added 4-dimethylaminopyridine (50 mg, 0.40 mmol) and di-*t*-butyldicarbonate (1.45 g, 1.1 equiv.). The mixture was stirred at room temperature for 18 h. The resulting brownish mixture was concentrated *in vacuo* at room temperature and the oily residue was partitioned between ethyl acetate (15 ml) and 1M KHSO₄ solution (15 ml). The organic portion was discarded and the pH of the aqueous layer was adjusted to 2 using 3M HCl solution. The aqueous layer was then extracted with ethyl acetate (2x15 ml). The organic extracts were dried, filtered and concentrated *in vacuo* to leave no product. Concentration of the aqueous layer gave a residue which by NMR spectroscopy showed only the unmodified amino acid to be present.

The three procedures outlined above were carried out on the α -ethyl analogue (138) and the same results were obtained, that is no *N*-BOC amino acid was isolated.

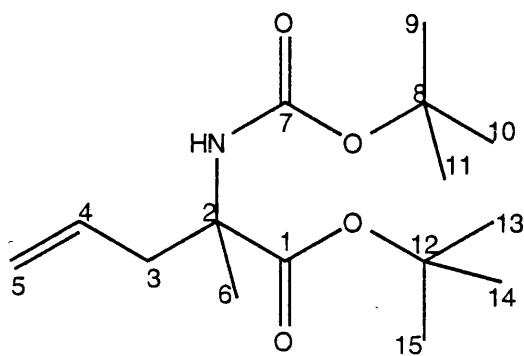
Attempted Preparation of Methyl 2-amino-2-methyl-4-Pentenoate Hydrochloride

Into a suspension of (137) (300 mg, 1.81 mmol) in anhydrous methanol (15 ml) was bubbled anhydrous hydrochloric acid gas at 0 °C until the solid had dissolved. The flask was then stoppered and allowed to stand at room

temperature for 2 h. The solution was cooled to 0 C and ether (150 ml) was added and the mixture was stirred until a solid precipitated. The solid was analysed by NMR spectroscopy and was found to be the HCl salt of the amino acid (analysis as for compound 137).



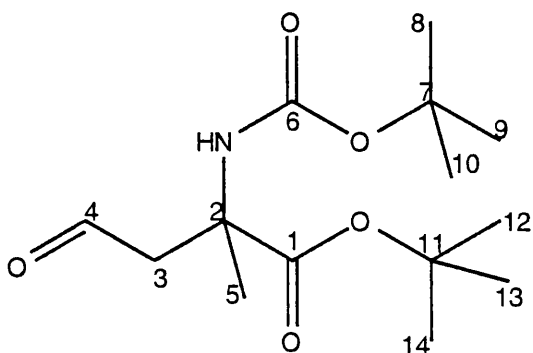
N-*t*-Butoxycarbonyl-2-methylallylglycine *t*-Butyl Ester (141)



To a solution of diisopropylamine (0.79 g, 2.1 equiv.) in anhydrous tetrahydrofuran (THF) (10 ml) at -20 C was added butyllithium (0.5 g, 2.1 equiv.), dropwise over a period of 15 min. This solution was stirred for a further 30 min at -20 C before the temperature was reduced to -78 C and the solution was diluted with anhydrous THF (35 ml). *N*-*t*-Butoxycarbonylallylglycine *t*-butyl ester (125) (1.0 g, 3.7 mmol) in anhydrous THF (25 ml) was added dropwise to the reaction over a period of 10 min. The solution turned a yellowish colour and was stirred at -78 C for 20 min to allow complete generation of the anion. Iodomethane (0.79 g, 1.5 equiv.) was then added to quench the anion and the solution was allowed to warm up to room temperature. The reaction mixture was heated at 40 C (water bath) overnight. Once cooled to room temperature the reaction was poured into saturated ammonium chloride solution (20 ml) and ether (30 ml) was added. The organic layer was separated and the aqueous layer was extracted with ether (2x25 ml). The organic extracts were combined, dried (Na₂SO₄), filtered and concentrated *in vacuo* to give the title compound as a light yellow oil. Chromatographic purification produced a clear oil, 0.9g (85.6% yield); ν_{max} (CHCl₃) 3050, 2910, 1740, 1710 and 1385 cm⁻¹; δ_{H} (200 MHz) (CDCl₃) 1.4-1.6 (21H, 3xs, 6-,9-,10-,11-,13-,14- and 15-H₃), 2.4-2.9 (2H, m, 3H₂), 5.0-5.2 (2H, m, 5H₂), 5.3 (1H, br s, NH), 5.6-5.8 (1H, m, 4H);

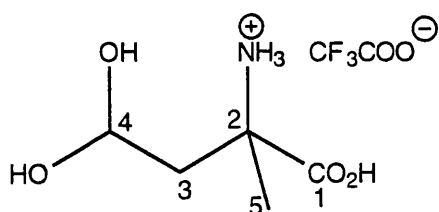
δ_C (50 MHz) ($CDCl_3$) 23.2 (C-6), 22.7 and 28.2 (C-9,10,11,13,14 and 15), 41.0 (C-3), 59.0 (C-2), 81.4 (C-8 and 12), 118.8 (C-5), 132.6 (C-4), 154.1 (C-7) and 173.0 (C-1); m/z 285 (M^+ , 1.2%), 270, 244, 229, 228, 171, 156, 115 and 57 (100%) (found: M^+ , 285.3720. $C_{15}H_{27}NO_4$ requires M^+ , 285.3713).

N-t-Butoxycarbonyl-2-methylaspartic Acid β -semialdehyde t-Butyl Ester (144)



A solution of (141) (0.5 g, 1.75 mmol) was ozonized according to general procedure 1. To the stirred blue solution at $-78\text{ }^\circ\text{C}$ was added triethylamine (0.35 g, 2 equiv.) and the solution was allowed to warm up to room temperature and was stirred overnight. The solution was then concentrated *in vacuo* and purification of the residue was achieved by column chromatography to give a light yellow oil, 0.4 g (80% yield); ν_{\max} ($CHCl_3$) 2920, 1740, 1710 and 1390 cm^{-1} ; δ_H (200 MHz) ($CDCl_3$) 1.4-1.6 (21H, 3xs, 5-, 7-, 8-, 9-, 12-, 13- and 14-H₃), 2.9 (2H, m, 3-H₂), 5.6 (1H, brs, NH) and 9.7 (1H, brs, 4-H); δ_C (50 MHz), ($CDCl_3$) 22.51 (C-5), 26.0 and 26.6 (C-7, 8, 9, 12, 13 and 14), 47.6 (C-3), 55.0 (C-2), 80.7 (C-6 and 11), 152.6 (C-10), 170.6 (C-1) and 198.1 (C-4); m/z 287 (M^+ , 2.6%), 272, 259, 202, 198, 144, 109, 57 (100%) and 41 (found: M^+ , 286.3450. $C_{14}H_{25}NO_5$ requires M^+ , 287.3448).

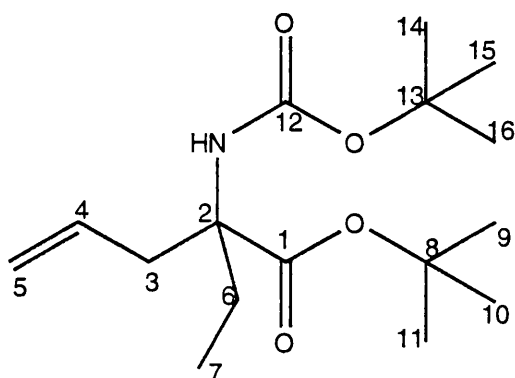
Trifluoro acetate salt of α -methyl aspartic acid β -semialdehyde (129)



Compound (144) (100 mg, 0.35 mmol) was dissolved in anhydrous dichloromethane (5 ml) and stirred in a flame dried flask under a dry nitrogen atmosphere at $0\text{ }^\circ\text{C}$. To this solution was added trifluoroacetic acid (2 ml) and the reaction was stirred for a further 2 h. Once the solvent had been removed

the title compound was isolated as a hygroscopic yellow solid, 38 mg (41% yield); ν_{\max} (CHCl_3) 3385 (broad), 3015 and 1718 cm^{-1} ; δ_{H} (200 MHz) (D_2O) 1.45 (3H, s, 5- H_3), 3.2 (2H, m, 3- H_2), 4.9 (1H, t, 4-H); δ_{C} (50 MHz) (D_2O) 23.2 (C-5), 52.1 (C-3), 57.5 (C-2), 95.1 (C-4), 175.4 (C-1); m/z 150 (M^+ , 0.1%), (found: M^+ , 150.0770. $\text{C}_5\text{H}_{12}\text{NO}_4$ requires M^+ , 150.0763).

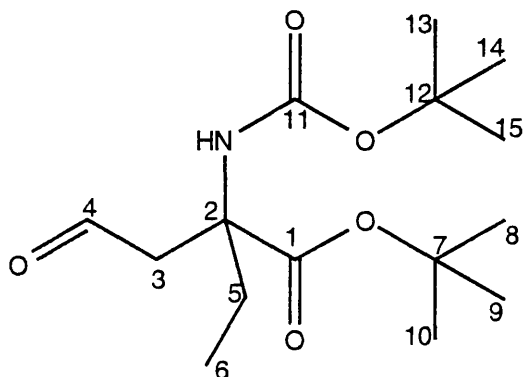
N-t-Butoxycarbonyl-2-ethylallylglycine t-Butyl Ester (142)



To a solution of diisopropylamine (0.79 g, 2.1 equiv.) in anhydrous tetrahydrofuran (THF) (10 ml) at -20 C was added butyllithium (0.5 g, 2.1 equiv.), dropwise over a period of 15 min. This solution was stirred for a further 30 min at -20 C before the temperature was reduced to -78 C and the solution was diluted with anhydrous THF (35 ml). *N*-t-Butoxycarbonylallylglycine t-butyl ester (125) (1.0 g, 3.7 mmol) in anhydrous THF (25 ml) was prepared and was added dropwise to the reaction over a period of 10 min. The solution turned a yellowish colour and was stirred at -78 C for 20 min to allow complete generation of the anion. Ethyl iodide (0.87 g, 1.5 equiv.) was then added to quench the anion and the solution was allowed to warm up to room temperature. The reaction was heated at 40 C (water bath) overnight. After cooling the reaction mixture was poured into saturated ammonium chloride solution (20 ml) and diluted with ether (30 ml). Separation of the organic layer and further extraction of the aqueous layer with ether (2x25 ml) gave the organic extracts which were combined, dried (Na_2SO_4), filtered and concentrated *in vacuo* to give the title compound as a light yellow oil. Chromatographic purification produced a colourless oil, 0.83g (75% yield); ν_{\max} (CHCl_3) 3065, 2930, 1745, 1700 and 1390 cm^{-1} ; δ_{H} (200 MHz) (CDCl_3) 1.1 (3H, t, J Hz, 7- H_3), 1.4 (18H, 2xs, 9-, 10-, 11-, 13-, 14- and 15- H_3), 1.45-1.6 (2H, m, 6- H_2), 2.3-2.6 (2H, m, 3- H_2), 5.1-5.3 (2H, m, 5- H_2), 5.4 (1H, brs, NH) and 5.6-6.7 (1H, m, 4-H), δ_{C} (50 MHz) (CDCl_3) 8.6 (C-7), 24.2 (C-6), 28.6 and 29.8 (C-9, 10, 11, 14, 15 and 16), 41.2 (C-3), 61.3 (C-2), 80.6 (C-8 and 13), 123.9 (C-5), 132.3 (C-4), 155.4 (C-12) and 174.9 (C-1), m/z 301 (M^+ , 5.4%),

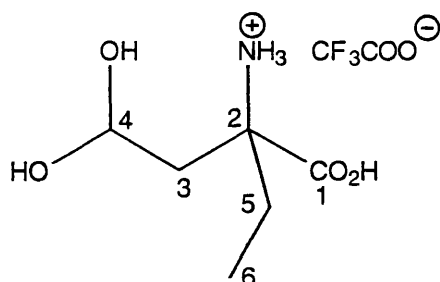
272, 244, 215, 212, 187, 158, 123 and 57 (100%) (found: M^+ , 301.3825. $C_{15}H_{27}NO_5$ requires M^+ , 301.3819).

N-*t*-Butoxycarbonyl-2-ethylaspartic Acid β -semialdehyde *t*-Butyl Ester (145)



A solution of (142) (0.5 g, 1.67 mmol) was ozonized according to general procedure 1. Triethylamine (0.34 g, 2 equiv.) was added and the solution was allowed to warm up to room temperature and was stirred overnight. The solution was then concentrated *in vacuo* and purification was achieved by column chromatography to give a light yellow oil, 0.39 g (77% yield); ν_{\max} ($CHCl_3$) 2940, 1740, 1735, 1715 and 1390 cm^{-1} , δ_H (200 MHz) ($CDCl_3$) 1.0 (3H, t, J 8.5 Hz, 6- H_3), 1.5 (18H, 2xs, 8-, 9-, 10-, 12-, 13- and 14- H_3), 1.5-1.6 (2H, m, 5- H_2), 2.7-2.9 (2H, m, 3- H_2), 5.4 (1H, brs, NH) and 9.75 (1H, s, 4- H), δ_C (50 MHz) ($CDCl_3$) 9.2 (C-6), 24.2 (C-5), 28.6 and 29.8 (C-8, 9, 10, 13, 14 and 15), 41.2 (C-3), 61.3 (C-2), 80.6 (C-7 and 12), 155.4 (C-11), 174.9 (C-1), and 201.4 (C-4), m/z 301 (M^+ , 1.9%), 272, 260, 244, 231, 212, 155, 123, 57 (100%) and 41 (found: M^+ , 301.3712. $C_{15}H_{27}NO_5$ requires M^+ 301.3708).

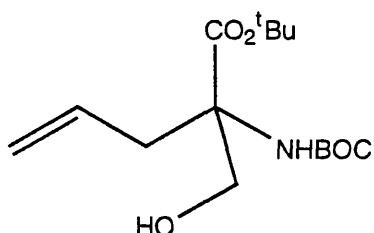
Trifluoro acetate salt of α -ethyl aspartic acid β -semialdehyde (130)



Compound (145) (100 mg, 0.33 mmol) was dissolved in anhydrous dichloromethane (5 ml) and deprotected as for compound (23) to leave the title compound was isolated as a hygroscopic yellow solid, 35 mg (38% yield); ν_{\max} ($CHCl_3$) 3450, 3005 and 1712 cm^{-1} ; δ_H (200 MHz) (D_2O) 1.10 (3H, t, J 7.9 Hz,

6-H₃), 1.65 (2H, m, 5-H₂), 3.24 (2H, m, 3-H₂) and 5.23 (1H, m, 4-H); δ_C (50 MHz) (D₂O) 10.5 (C-6), 25.4 (C-5), 49.8 (C-3), 60.8 (C-2), 98.3 (C-4) and 176.6 (C-1); m/z 164 (M⁺, 0.4%) (found: M⁺, 164.0925. C₆H₁₄NO₄ requires M⁺, 164.0919).

Attempted preparation of *N*-*t*-Butoxycarbonyl-2-hydroxymethylallylglycine *t*-Butyl Ester (143)

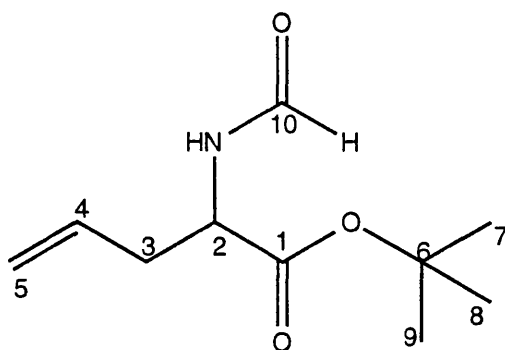


To a solution of diisopropylamine (0.53 ml, 2.1 equiv.) in anhydrous tetrahydrofuran (THF) (10 ml) at -20 °C was added butyllithium (2.53 ml, 2.1 equiv.), dropwise over a period of 15 min. This solution was stirred for a further 30 min at -20 °C before the temperature was reduced to -78 °C and the solution was diluted with anhydrous THF (35 ml). *N*-*t*-Butoxycarbonylallylglycine *t*-butyl ester (125) (0.5 g, 1.85 mmol) in anhydrous THF (25 ml) was prepared and added dropwise to the reaction over a period of 10 min. The solution turned a yellowish colour and was stirred at -78 °C for 20 min to allow complete generation of the anion. Paraformaldehyde (0.20 g, 4.0 equiv.) was then added to quench the anion and the solution was allowed to warm up to room temperature. The mixture was heated at 40 °C (water bath) overnight. Once cooled to room temperature the mixture was poured into saturated ammonium chloride solution (20 ml) and was diluted with ether (30 ml). Separation of the organic layer and further extraction of the aqueous layer with ether (2x25 ml) yielded the organic extracts which once combined, dried (Na₂SO₄), filtered and concentrated *in vacuo* gave the starting material.

N-Formylallylglycine *t*-Butyl Ester (147)

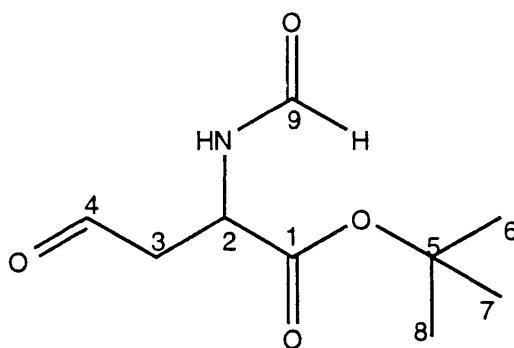
Dicyclohexylcarbodiimide (2.86 g, 2 equiv.) was added to a solution of formic acid (0.89 g, 4 equiv.) in dichloromethane (15 ml) at 0 °C with stirring for 15 min. A cooled solution of (124) (1.0 g, 4.82 mmol) and *N*-methylmorpholine (0.97 g, 2 equiv.) in dichloromethane (10 ml) was added and the resultant mixture was stirred in a water bath for 20 h. The reaction mixture was washed with 5% aqueous citric acid solution (2x20 ml), aqueous sodium bicarbonate solution (2x15 ml) and brine (2x20 ml). The organic layer was dried (Na₂SO₄),

filtered and removal of the solvent *in vacuo* gave a clear oil, 0.91 g (95% yield);



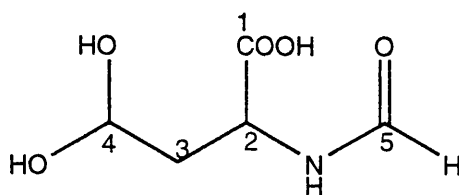
ν_{\max} (CHCl_3) 3405, 3010, 1725, 1685 and 1490 cm^{-1} ; δ_{H} (200 MHz) (CDCl_3) 1.5 (9H, s, 7-, 8- and 9- H_3), 2.5 (2H, m, 3- H_2), 4.7 (1H, dd, 2-H), 5.1 (2H, m, 5- H_2), 5.7 (1H, m, 4-H), 6.6 (1H, brs, NH) and 8.2 (1H, d, 10-H); δ_{C} (50 MHz) (CDCl_3) 27.8 (C-7, -8 and -9), 36.5 (C-3), 50.6 (C-2), 82.3 (C-6), 118.9 (C-5), 131.9 (C-4), 160.5 (C-10) and 170.3 (C-1); m/z 199 (M^+ , 0.1%), 158, 143, 126, 98, 70 and 57 (100%) (found: M^+ , 199.1202. $\text{C}_{10}\text{H}_{17}\text{NO}_3$ requires M^+ , 199.1208).

N-Formylaspartic Acid β -semialdehyde *t*-Butyl Ester (148)



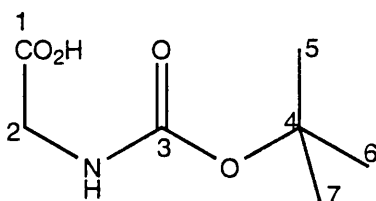
A solution of compound (147) (900 mg, 4.6 mmol) was saturated with ozone according to general procedure 1. Triethylamine (1.87 g, 2 equiv.) was added with stirring and the solution was allowed to warm up to room temperature overnight. Removal of the solvent *in vacuo* followed by silica gel flash chromatography gave the product as a clear oil, 0.68 g (75% yield); ν_{\max} (CHCl_3) 3415, 3025, 2985, 1735, 1685 and 1500 cm^{-1} ; δ_{H} (200 MHz) (CDCl_3) 1.44 (9H, s, 6-, 7- and 8- H_3), 3.08 (2H, dd, 3- H_2), 4.75 (1H, dd, 2-H), 6.58 (1H, brs, NH), 8.17 (1H, s, 9-H) and 9.7 (1H, s, 4-H), δ_{C} (50 MHz) (CDCl_3) 27.8 (C-6, -7 and -8), 45.7 (C-3), 46.7 (C-2), 83.3 (C-5), 160.6 (C-9), 169.1 (C-1) and 199.1 (C-4); m/z 172 ($\text{M}^+ - \text{CHO}$), 158, 128, 100, 72, 57 (100%) and 41.

N-Formylaspartic Acid β -semialdehyde Hydrate (146)



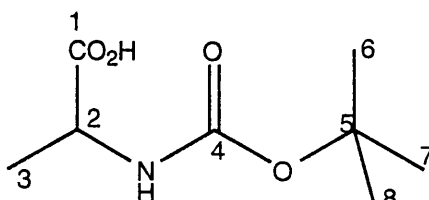
Compound (148) (100 mg, 0.5 mmol) was dissolved in anhydrous dichloromethane (5 ml) and stirred in a flame dried flask under a dry nitrogen atmosphere at 0 C. To this solution was added trifluoroacetic acid (2 ml) and the reaction was stirred for a further 2 h. Once the solvent had been removed the title compound was isolated as a yellow oil, 75 mg (92% yield); ν_{\max} (CHCl₃) 3420 (broad), 2920, 1770, 1725, 1665 and 1520 cm⁻¹; δ_{H} (200 MHz) (CHCl₃) 1.7 (2H, m, 3-H₂), 4.2 (1H, m, 2-H), 4.7 (1H, m, 4-H) and 7.7 (1H, s, 5-H), δ_{C} (50 MHz) (CDCl₃) 38.9 (C-3), 49.3 (C-2), 88.8 (C-4), 164.9 (C-5) and 175.5 (C-1); m/z 163 (M⁺, 0.8%), 144, 135, 119, 118, 44 and 28 (100%) (found: M⁺, 163.0488. C₅H₉NO₅ requires M⁺, 163.0481).

N-*t*-Butoxycarbonylglycine (161)¹⁶⁴



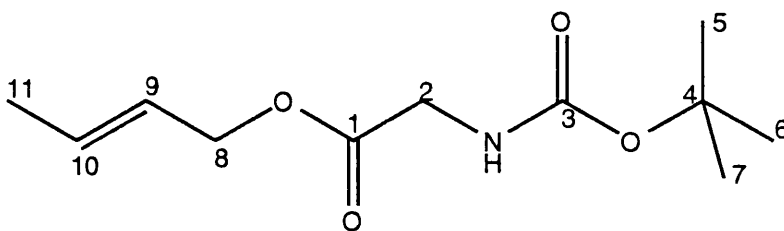
To a solution of glycine (10 g, 133.3 mmol) in water/dioxane mixture (200 ml, 1:1) was added potassium bicarbonate (16.0 g, 1.2 equiv.) and di-*t*-butyldicarbonate (29 g, 1.1 equiv.). The resulting suspension was stirred for 12 h then the mixture was washed with ether (75 ml). The aqueous layer was adjusted to pH 2 with 2M HCl solution. The aqueous layer was then extracted with ethyl acetate (2x70 ml). The organic extracts were dried (Na₂SO₄), filtered and the solvent removed under reduced pressure to leave an off-white solid, 23 g (98% yield); m.p. 88-89 C (lit.,¹⁶³ m.p 87-88 C); δ_{H} (360 MHz) (CDCl₃) 1.45 (9H, s, 5-, 6- and 7-H₃) 3.9 (2H, d, J 5.5 Hz, 2-H₂), 5.3 (1H, brs, NH) and 11.3 (1H, brs, CO₂H); δ_{C} (90 MHz) (CDCl₃) 28.2 (C-5, -6 and -7), 42.1 (C-2), 80.4 (C-4), 156.0 (C-3) and 174.6 (C-1); m/z 174 (M⁺-H, 0.1%), 130, 74 and 57 (100%) (found: M⁺-H, 174.1720. C₇H₁₂NO₄ requires M⁺-H 174.1712).

N-*t*-Butoxycarbonylalanine (162)¹⁶⁵



To a solution of alanine (5 g, 56.1 mmol) in water/dioxane mixture (150 ml, 1:1) was added potassium bicarbonate (6.7 g, 1.2 equiv.) and di-*t*-butyldicarbonate (13.5 g, 1.1 equiv.). The resulting suspension was stirred for 12 h before the mixture was washed with ether (60 ml). The pH of the aqueous layer was adjusted to 2 with 2M HCl solution. The aqueous layer was then extracted with ethyl acetate (2x50 ml). The organic extracts were dried (Na₂SO₄), filtered and the solvent removed under reduced pressure to leave an off-white solid, 10.0 g (95% yield); m.p. 79-81 °C (lit.,¹⁶⁴ m.p. 80-82 °C); δ_{H} (200 MHz) (CDCl₃) 1.3 (3H, d, *J* 6.5 Hz, 3-H₃), 1.45 (9H, s, 6-, 7- and 8-H₃) 4.1 (1H, m, 2-H), 5.6 (1H, brs, NH) and 11.0 (1H, brs, CO₂H); δ_{C} (50 MHz) (CDCl₃) 18.4 (C-3), 29.4 (C-6, -7 and -8), 48.9 (C-2), 80.6 (C-5), 160.9 (C-4) and 175.5 (C-1); *m/z* 188 (M⁺-H, 0.3%), 173, 143, 88 and 57 (100%) (found: M⁺-H, 188.0925. C₈H₁₄NO₄ requires M⁺-H 188.0919).

(*E*)-2-Butenyl *N*-(*t*-butoxycarbonyl)amino-acetate (156)

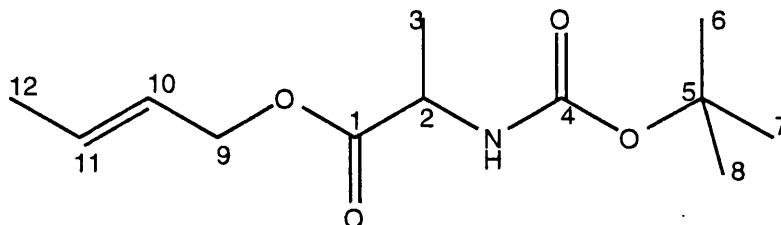


General Procedure 2

A mixture of *trans*-crotyl alcohol (6.5 ml, 18.6 mmol), *N*-*t*-butoxycarbonylglycine (3.25 g, 18.6 mmol), dicyclohexylcarbodiimide (3.8 g, 18.6 mmol) and a catalytic amount of 4-(dimethylamino)pyridine (100 mg) in anhydrous ether (30 ml) was stirred at room temperature for 18 h. After removal of the precipitated dicyclohexylurea by filtration, the solution was washed with saturated sodium bicarbonate solution (2x10 ml), dried (MgSO₄), filtered and concentrated at reduced pressure. The crude oil was purified by silica gel chromatography to leave a colourless oil, 3.4 g (80% yield); ν_{max} (CHCl₃) 3490, 3000, 1720 and 1500 cm⁻¹; δ_{H} (200 MHz) (CDCl₃) 1.4 (9H, s, 5-, 6- and 7-H₃), 1.7 (3H, dd, *J*

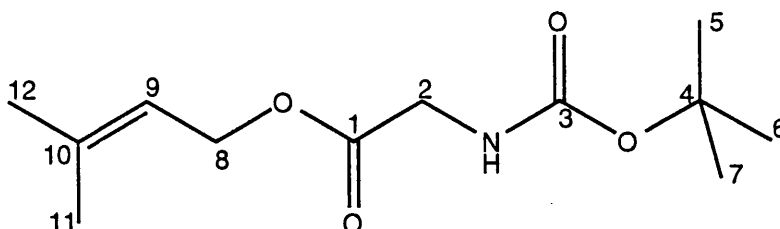
6.3, 1.25 Hz, 11-H₃), 3.88 (2H, brd, *J* 5.7 Hz, 2-H₂), 4.55 (2H, brd, *J* 6.4 Hz, 8-H₂), 5.3 (1H, brt, *J* 5.3 Hz, NH) and 5.7 (2H, m, 9- and 10-H); δ_{C} (50 MHz) (CDCl₃) 17.4 (C-11), 28.0 (C-5, -6 and -7), 42.1 (C-2), 65.5 (C-8), 79.4 (C-4), 124.3 (C-10), 131.6 (C-9), 155.5 (C-3) and 169.9 (C-1); *m/z* 174 (M-CH₂CH=CH(Me), 0.5%), 130, 74, 57 (100%) and 41 (found: M-CH₂CH=CH(Me), 174.1715. C₇H₁₂NO₄ requires M, 174.1711).

(E)-2-Butenyl N-(*t*-butoxycarbonylamino)propionate (165)



The title compound was prepared using general procedure 2 with the following reagents: *trans*-crotyl alcohol (1.34 g, 7.1 mmol), *N*-*t*-butoxycarbonylalanine (3.15 g, 7.1 mmol), dicyclohexylcarbodiimide (3.71g, 7.1 mmol) and 4-(dimethylamino)pyridine (10 mg). The product was isolated as a clear oil, 1.2 g (70% yield); ν_{max} (CHCl₃) 3450, 3000, 1740 and 1500 cm⁻¹; δ_{H} (200 MHz) (CDCl₃) 1.36 (3H, d, *J* 7.2 Hz, 3-H₃), 1.42 (9H, s, 6-, 7- and 8-H₃), 1.7 (3H, dd, *J* 6.3, 1.15 Hz, 12-H₃), 4.3 (1H, brt, 2-H), 4.6 (2H, d, *J* 6.3 Hz, 9H₂) and 5.6 (2H, m, 10- and 11-H); δ_{C} (50 MHz) (CDCl₃) 17.3 (C-12), 17.9 (C-3), 27.8 (C-6, -7 and -8), 48.9 (C-2), 65.4 (C-9), 79.1 (C-5), 124.3 (C-10), 131.1 (C-11), 154.8 (C-4) and 172.8 (C-1); *m/z* 188 (M-CH₂CH=CH(CH₃), 0.3%), 174, 144, 87, 57 (100%), 55 and 41 (found: M-CH₂CH=CH(CH₃), 188.1965. C₈H₁₄NO₄ requires M-CH₂CH=CH(CH₃), 188.1971).

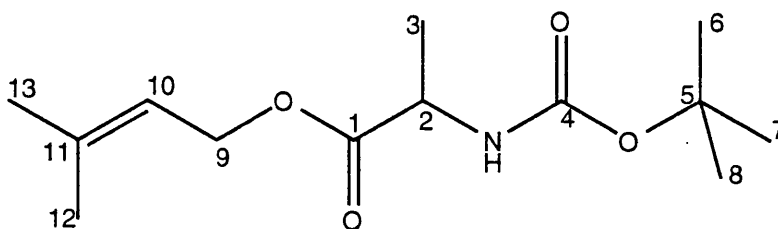
2-(3-Methyl)butenyl N-(*t*-butoxycarbonylamino)acetate (166)



The title compound was prepared using general procedure 2 with the following reagents: 3-methyl-2-buten-1-ol (1.4 ml, 14.29 mmol), *N*-*t*-butoxycarbonylglycine (2.5 g, 14.29 mmol), dicyclohexylcarbodiimide (2.9 g, 14.29 mmol) and 4-(dimethylamino)pyridine (10 mg). The product was isolated as a clear oil, 2.43 g (70% yield); ν_{max} (CHCl₃) 3320, 2975, 1680, 1490 cm⁻¹;

δ_{H} (200 MHz) (CDCl_3) 1.45 (9H, s, 5-, 6- and 7- H_3), 1.75 (6H, d, J 8.7 Hz, 11- and 12- H_3), 4.0 (2H, d, J 6.1 Hz, 2- H_2), 4.5 (2H, brd, J 6.5 Hz, 8- H_2), 5.5 (1H, brt, J 5.8 Hz, NH) and 5.7 (1H, m, 9-H); δ_{C} (50MHz) (CDCl_3) 17.9 (C-12), 22.6 (C-11), 28.9 (C-5, -6 and -7), 41.9 (C-2), 64.8 (C-8), 80.1 (C-4), 118.6 (C-9), 138.9 (C-10), 154.5 (C-3) and 174.2 (C-1); m/z 188 (M-CH=CMe₂, 1.1%), 187, 130, 74, 69 and 57 (100%) (found: M-CH=CMe₂, 188.1980. C₈H₁₄NO₄ requires M-CH=CMe₂, 188.1971).

2-(3-Methyl)butenyl *N*-(*t*-butoxycarbonylamino)propionate (167)



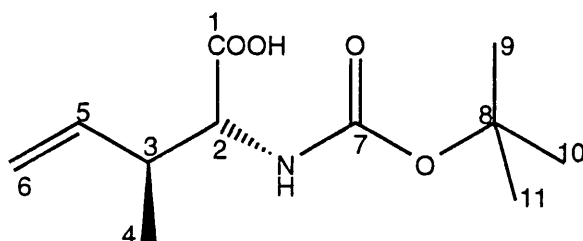
The title compound was prepared using general procedure 2 with the following reagents: 3-methyl-2-buten-1-ol (2.1 ml, 21.16 mmol), *N*-(*t*-butoxycarbonyl)alanine (4.0 g, 21.16 mmol), dicyclohexylcarbodiimide (4.4 g, 21.16 mmol) and 4-(dimethylamino)pyridine (20 mg). The product was isolated as a clear golden oil, 3.41 g (62% yield); ν_{max} (CHCl_3) 3450, 3000, 1740, 1660 cm^{-1} ; δ_{H} (200 MHz) (CDCl_3) 1.4 (3H, d, J 7.2 Hz, 3- H_3), 1.5 (9H, s, 6-, 7- and 8- H_3), 1.75 (6H, d, J 8.9 Hz, 11- and 12- H_3), 4.3 (1H, brt, J 7.2 Hz, 2-H), 4.7 (2H, d, J 7.2 Hz, 9- H_2) and 5.35 (1H, m, 10-H); δ_{C} (50 MHz) (CDCl_3) 17.8 (C-13); 18.4 (C-3), 25.5 (C-12), 28.0 (C-6, -7 and -8), 49.1 (C-2), 61.9 (C-9), 79.4 (C-5), 118.1 (C-10), 139.2 (C-11), 155.1 (C-4) and 173.2 (C-1); m/z 201 (M⁺-CH=CMe₂, 3.3%), 144, 88, 69 and 57 (100%) (found M⁺-CH=CMe₂ 201.1001. C₉H₁₅NO₄ requires M⁺-CH=CMe₂ 201.0997).

3-Methyl- *N*-(*t*-butoxycarbonylamino)-4-pentenoic Acid (157)¹⁶³

General Procedure 3

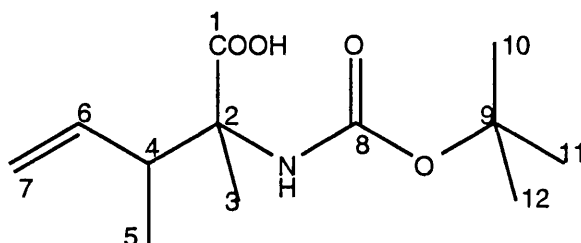
Into a flame dried 3-necked round-bottomed flask, under a dry nitrogen atmosphere, equipped with a condenser and a suba-seal, was placed a solution of diisopropylamine (0.95 g, 9.39 mmol) in anhydrous THF (10 ml) at 0 °C. To this was added, dropwise over 10 min, 1.6M *n*-butyllithium in hexanes (0.6 g, 9.39 mmol). After 10 min the solution was cooled to -78 °C (acetone/dry-ice bath) and compound (156) (1.0 g, 4.37 mmol) in anhydrous THF (5 ml) was added over about 60 s. Stirring was continued at -78 °C for 10 min and then

trimethylsilyl chloride (1.1 g, 9.39 mmol) was added and the solution was stirred for a further 5 min before being allowed to warm up to room temperature over a period of 15 min. The mixture was then heated at reflux for 1 h, cooled, and diluted with methanol (10 ml), to hydrolyse the silyl ethers, and stirred for 5 min. The solution was diluted with ether (25 ml) and extracted with 2M sodium hydroxide solution (4x5 ml). The combined aqueous extracts were then acidified to pH 1 with 3M HCl solution and extracted with chloroform (3x10 ml). The organic extracts were dried (MgSO₄), filtered and concentrated at reduced pressure to produce 0.68 g (68 % yield) of the rearranged product as a mixture of diastereomers;



ν_{\max} (CHCl₃) 3300, 2975, 1780 and 1600 cm⁻¹; δ_{H} (200 MHz) (CDCl₃) 1.1 (3H, d, *J* 7.0 Hz, 4-H₃), 1.4 (9H, s, 9-, 10- and 11-H₃), 2.7 (1H, m, 3-H), 4.2 (1H, m, 2-H), 5.1 (2H, m, 6-H₂), 5.8 (1H, m, 5-H) and 10.9 (1H, brs, CO₂H); δ_{C} (50 MHz) (CDCl₃) 15.0 (C-4), 28.3 (C-9, -10 and -11), 40.3 (C-3), 57.2 (C-2), 80.1 (C-8), 116.2 (C-6), 138.5 (C-5), 155.5 (C-7) and 176.2 (C-1) (signals visible for the minor diastereoisomer 14.7 (C-4), 39.9 (C-2) and 58.8 (C-3); *m/z* 173 (M-(Me)HCCH=CH₃, 1.5%), 128, 112, 101, 74, 57 (100 %) and 55 (found: M-(Me)HCCH=CH₃, 173.0687. C₇H₁₁NO₄ requires M-(Me)HCCH=CH₃, 173.0674).

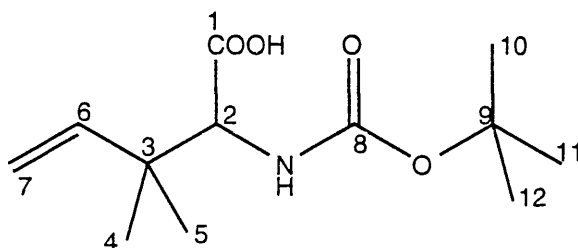
2.3-Dimethyl-N-(*t*-butoxycarbonylamino)-4-pentenoic Acid (158)



The title compound was prepared using general procedure 3 with the following reagents: (*E*)-2-(3-methyl)butenyl-*N*-(*t*-butoxycarbonylamino)propionate (1.55 g, 6.38 mmol) was added to a solution of LDA generated from diisopropylamine (1.34 g, 13.73 mmol) and 1.6 M butyllithium (0.88 g, 13.73 mmol) and then trimethylsilyl chloride (1.5 g, 13.73 mmol) was added. After removal of the

organic solvent the product was isolated as a pale yellow solid, 1.2 g (80 % yield); mp 122-125 C; ν_{\max} (CHCl₃) 3300, 2980, 1715, 1625 cm⁻¹; δ_{H} (200 MHz) (CDCl₃) 1.1 (3H, d, *J* 6.9 Hz, 3-H₃), 1.4 (12H, brs, 5-, 10-, 11- and 12-H₃), 2.7 (1H, m, 4-H), 5.2 (2H, m, 7-H₂), 5.8 (1H, m, 6-H) and 10.4 (1H, brs, CO₂H); δ_{C} (50 MHz) (CDCl₃) 15.1 (C-5), 20.4 (C-3), 28.3 (C-10, -11 and -12), 45.4 (C-4), 61.9 (C-2), 80.0 (C-9), 117.4 (C-7), 137.9 (C-6), 155.4 (C-8) and 177.6 (C-1) (signals visible for the other diastereoisomer 14.87 (C-5), 44.80 (C-4), 61.59 (C-2), 118.17 (C-7) and 178.14 (C-1)); *m/z* 187 (M-(Me)HCCH=CH₃, 1.2 %), 128, 126, 89, 74, 57 (100 %) and 55 (found: M-(Me)HCCH=CH₃, 187.1901. C₈H₁₃NO₄ requires M-(Me)HCCH=CH₃, 187.1897).

3,3-Dimethyl-*N*-(*t*-butoxycarbonylamino)-4-pentenoic Acid (159)

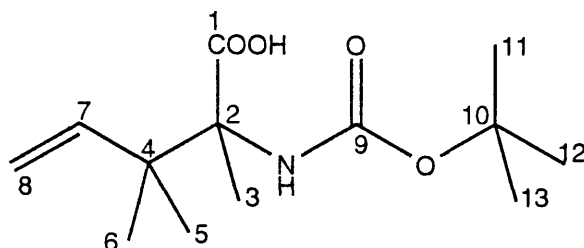


The title compound was prepared using general procedure 3 with the following reagents. 2-(3-Methyl)butenyl-*N*-(*t*-butoxycarbonylamino)acetate (166) (1.0 g, 4.11 mmol) was added to a solution of LDA generated from diisopropylamine (0.87 g, 8.85 mmol) and 1.6 M butyllithium (0.57 g, 8.85 mmol) and then trimethylsilyl chloride (0.96 g, 8.85 mmol) was added. After removal of the organic solvent the product was isolated as a pale yellow solid, 0.79 g (79 % yield); mp 123-125 C; ν_{\max} (CHCl₃) 3440, 2890, 1710 and 1500 cm⁻¹; δ_{H} (200 MHz) (CDCl₃) 1.1 (6H, brs, 4- and 5-H₃), 1.4 (9H, s, 10-, 11- and 12-H₃), 4.0 (1H, d, *J* 8.3 Hz, 2-H), 5.1 (2H, m, 7-H₂), 5.9 (1H, m, 6-H) and 10.6 (1H, brs, CO₂H); δ_{C} (50 MHz) (CDCl₃) 23.6 and 24.1 (C-4 and -5), 28.2 (C-10, -11 and -12), 39.5 (C-3), 60.9 (C-2), 80.0 (C-9), 114.0 (C-7), 142.7 (C-6) and 176.2 (C-1); *m/z* 174 (M-(Me)₂CC=CH₂, 1.9 %), 117, 72, 69 and 57 (100%) (found: M-(Me)₂C=CH₂, 174.0770. C₇H₁₂NO₄ requires M-(Me)₂C=CH₂, 174.0763).

2,3,3-Trimethyl-*N*-(*t*-butoxycarbonylamino)-4-pentenoic Acid (160)

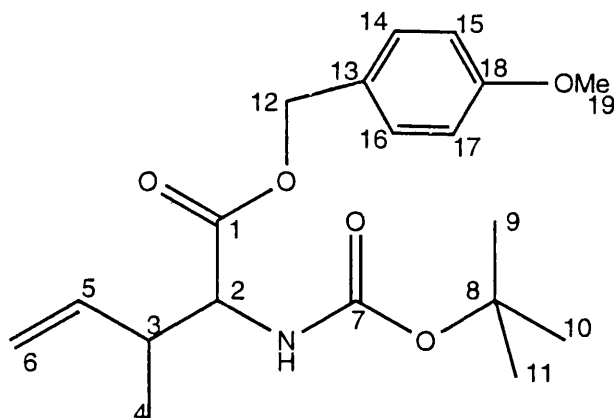
The title compound was prepared using general procedure 3 with the following reagents. 2-(3-Methyl)butenyl-*N*-(*t*-butoxycarbonylamino)acetate (167) (2.0 g, 7.8 mmol) was added to a solution of LDA generated from diisopropylamine (1.6 g, 16.4 mmol) and 1.6 M butyllithium (1.05 g, 16.4 mmol) and then trimethylsilyl chloride (1.8 g, 16.4 mmol) was added. After removal of the

organic solvent the product was isolated as a light brown solid, 150 mg (7.5 % yield);



mp 110-112 °C, ν_{\max} (CHCl₃) 2950, 1710, 1660 and 1600 cm⁻¹; δ_{H} (200 MHz) (CDCl₃) 1.1 (3H, s, 3-H₃), 1.37 (6H, s, 5- and 6-H₃), 1.4 (9H, s, 11-, 12- and 13-H₃), 5.3 (2H, m, 8-H₂), 6.0 (1H, m, 7-H) and 10.5 (1H, brs, CO₂H); δ_{C} (50 MHz) (CDCl₃) 18.4 (C-3), 21.9 and 22.8 (C-5 and -6), 28.3 (C-11, -12 and -13), 43.2 (C-4), 50.3 (C-2), 80.1 (C-10), 114.9 (C-8), 142.7 (C-7), 155.5 (C-9) and 177.5 (C-1); m/z 188 (M-(Me)₂CCH=CH₂, 0.7%), 173, 131, 116, 87, 69 and 57 (100%) (found: M-(Me)₂CCH=CH₂, 188.1962. C₈H₁₄NO₄ requires M-(Me)₂CCH=CH₂, 188.1971).

p-Methoxybenzyl 3-methyl-*N*-(*t*-butoxycarbonylamino)-4-pentenoate (173)



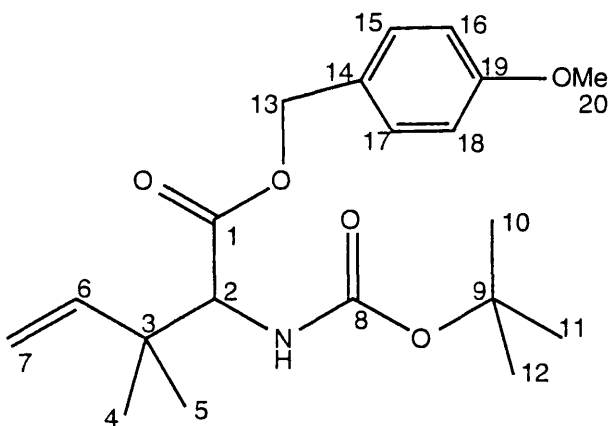
General procedure 4

To a solution of compound (157) (0.5 g, 2.18 mmol) in anhydrous dimethylformamide (DMF) (10 ml) was added potassium bicarbonate (0.44 g, 2 equiv.) and 4-methoxybenzyl chloride (0.37 g, 2.4 mmol). The mixture was stirred at room temperature for 48 h. The solution was diluted with ethyl acetate (25 ml) and washed with saturated brine (5x20 ml) and water (20 ml). The organic layer was dried (Na₂SO₄), filtered and concentrated under reduced pressure to leave an orange coloured oil which was purified by silica gel chromatography to leave a pale yellow oil, 0.65 g (85.4% yield); ν_{\max} (CHCl₃)

3010, 1720, 1600 cm^{-1} ; δ_{H} (200 MHz) (CDCl_3) 1.0 (3H, d, J 7.0 Hz, 4- H_3), 1.4 (9H, s, 9-, 10- and 11- H_3), 2.6 (1H, m, 3-H), 3.8 (3H, s, 19- H_3), 4.3 (1H, m, 2-H), 5.0 (4H, m, 6- and 12- H_2), 5.7 (1H, m, 5-H), 6.9 (2H, d, J 8.7 Hz, 14- and 16-H) and 7.3 (2H, d, J 8.7 Hz, 15- and 17-H); δ_{C} (50 MHz) (CDCl_3) 15.3 (C-4), 28.3 (C-9, -10 and -11), 40.8 (C-3), 55.3 (C-19), 57.4 (C-2), 66.8 (C-12), 116.1 (C-6), 138.7 (C-5) 113.9, 127.5, 130.3, 155.4 (aromatic carbons), 159.7 (C-7) and 171.6 (C-1); m/z 349 (M^+ , 0.1%), 294, 121, 91, 84 (100%) and 73 (found: M^+ , 349.4160. $\text{C}_{19}\text{H}_{27}\text{NO}_5$ requires M^+ 349.4153).

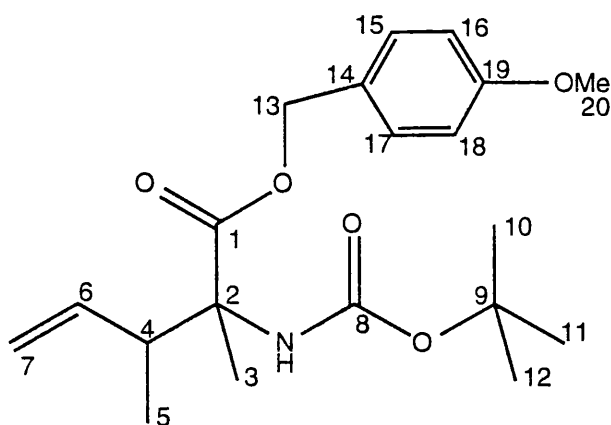
p-Methoxybenzyl 3,3-dimethyl-*N*-(*t*-butoxycarbonylamino)-4-pentenoate (174)

The title compound was prepared using general procedure 4 with the following reagents. Compound (158) (0.46 g, 1.88 mmol) was used with 4-methoxybenzyl chloride (0.28 ml, 1.5 equiv.) and potassium bicarbonate (188 mg, 1.1 equiv.). The product was isolated as a clear oil after silica gel chromatography, 0.6 g (85.6% yield);



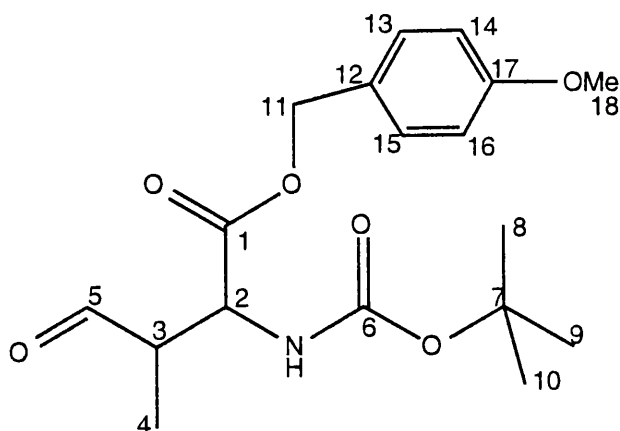
ν_{max} (CHCl_3) 3030, 1715, 1600 cm^{-1} ; δ_{H} (200 MHz) (CDCl_3) 1.0 (6H, d, J 4.6 Hz, 4- and 5- H_3), 1.5 (9H, s, 10-, 11- and 12- H_3), 3.9 (3H, s, 20- H_3), 4.1 (1H, d, J 9.2 Hz, 2-H), 5.0 (5H, m, 7- and 13- H_2 and NH), 5.8 (1H, dd, J 11, 17 Hz, 6-H), 6.9 (2H, d, J 6.6 Hz, 15- and 17-H) and 7.3 (2H, d, J 6.8 Hz, 16- and 18-H); δ_{C} (50 MHz) (CDCl_3) 23.3 and 24.3 (C-4 and -5), 28.2 (C-10, -11 and -12), 40.4 (C-3), 55.2 (C-20), 60.9 (C-2), 66.5 (C-13), 80.1 (C-9), 113.8, 127.47, 130.3, 143.0 (aromatic carbons), 151.3 (C-8) and 171.7 (C-1); m/z 322 ($\text{M}-\text{CH}_2=\text{CHCH}_2$, 1.9%), 254, 222, 121 (100%), 91, 69 and 57 (found: $\text{M}-\text{CH}_2=\text{CHCH}_2$, 322.1652. $\text{C}_{17}\text{H}_{24}\text{NO}_5$ requires $\text{M}-\text{CH}_2=\text{CHCH}_2$, 322.1648).

p-Methoxybenzyl 2,3-dimethyl-*N*-(*t*-butoxycarbonylamino)-4-pentenoate (175)



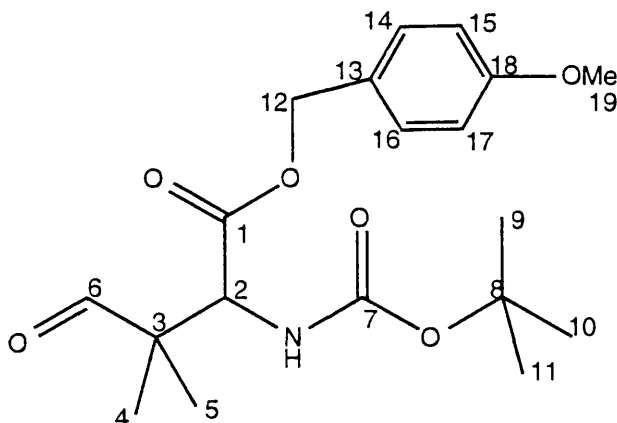
The title compound was prepared using general procedure 4 with the following reagents. Compound (159) (0.50 g, 2.06 mmol) was used with 4-methoxybenzyl chloride (0.51 g, 1.5 equiv.) and potassium bicarbonate (227 mg, 1.1 equiv.). The product was isolated as a clear oil after silica gel chromatography, 0.63 g (84.3% yield); ν_{\max} (CHCl₃) 3030, 1715, 1600 cm⁻¹; δ_{H} (200 MHz) (CDCl₃) 1.0 (3H, d, *J* 7 Hz, 5-H₃), 1.4 (12H, s, 3-, 10-, 11- and 12-H₃), 3.7 (3H, s, 20-H₃), 5.1 (4H, m, 7- and 13-H₂), 5.7 (1H, m, 6-H), 6.9 (2H, m, 15- and 17-H₂) and 7.4 (2H, m, 16- and 18-H₂); δ_{C} (50 MHz) (CDCl₃) 14.7 (C-5), 20.3 (C-3), 28.1 (C-10, -11 and -12), 41.5 (C-4), 56.6 (C-20), 60.2 (C-2), 65.9 (C-13), 80.1 (C-9), 117.2 (C-7), 138.4 (C-6), 113.8, 127.5, 130.3, 143.0 (aromatic carbons), 153.7 (C-8) and 170.9 (C-1); *m/z* 363 (M⁺, 0.8%), 308, 121, 91, 84 (100%), 87 and 73 (found: M⁺, 363.4420. C₂₀H₂₉NO₅ requires M⁺ 363.4413).

p-Methoxybenzyl 3-methyl-*N*-(*t*-butoxycarbonylamino)aspartic Acid β -semialdehyde (176)



The title compound was prepared by saturating a solution of compound (173) (250 mg, 0.72 mmol) with ozone in accordance with general procedure 1. Triethylamine (0.2 ml, 2 equiv.) was added to decompose the ozonide formed and the solution was allowed to warm up to room temperature overnight. The compound was purified by silica gel chromatography to give the title compound as a clear oil, 200 mg (80% yield); ν_{max} (CHCl₃) 3400, 3040, 1745, 1720, 1610 and 1500 cm⁻¹; δ_{H} (200 MHz) (CDCl₃) 1.1 (3H, d, *J* 7 Hz, 4-H₃), 1.4 (9H, s, 8-, 9- and 10-H₃), 3.0 (1H, m, 3-H), 3.8 (3H, s, 18-H₃), 4.7 (1H, m, 2-H), 5.1 (2H, s, 11-H₂), 6.9 and 7.4 (4H, m, 13-, 14-, 15- and 16-H), 9.6 (1H, s, 5-H); δ_{C} (50 MHz) (CDCl₃) 9.50 (C-4), 28.1 (C-8, -9 and -10), 49.0 (C-3), 53.6 (C-2), 55.1 (C-18), 67.3 (C-11), 80.0 (C-7), 113.9, 127.0 and 130.3 (aromatic carbons), 160.0 (C-6), 171.1 (C-1) and 200.1 (C-5); *m/z* 351 (M⁺, 0.7%), 311, 294, 249, 186, 130, 121 (100%) and 57 (found: M⁺, 351.1672. C₁₈H₂₅NO₆ requires M⁺, 351.1675).

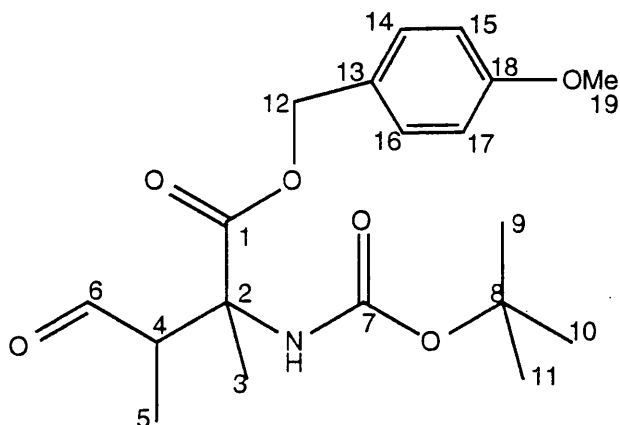
p-Methoxybenzyl 3,3-dimethyl-*N*-(*t*-butoxycarbonylamino)aspartic Acid β -semialdehyde (177)



The title compound was prepared by saturating a solution of compound (174) (500 mg, 1.44 mmol) with ozone in accordance with general procedure 1. Triethylamine (0.4 ml, 2 equiv.) was added to decompose the ozonide formed and the solution was allowed to warm up to room temperature overnight. The compound was purified by silica gel chromatography to give the title compound as a clear oil, 450 mg (90% yield); ν_{max} (CHCl₃) 3400, 3010, 2920, 1740, 1720 and 1695 cm⁻¹; δ_{H} (200 MHz) (CDCl₃) 0.9 and 1.0 (6H, 2xs, 4- and 5-H₃), 1.3 (9H, s, 9-, 10- and 11-H₃), 3.7 (3H, s, 19-H₃), 4.6 (1H, brd, *J* 9.5 Hz, 2-H), 5.0 (2H, s, 12-H₂), 5.2 (1H, brd, *J* 9.5 Hz, NH), 6.8 (2H, m, 15- and 17-H), 7.2 (2H, m, 14- and 18-H) and 9.5 (1H, s, 6-H); δ_{C} (50 MHz) (CDCl₃) 17.5 and 18.8 (C-4 and -5), 28.1 (C-9, -10 and -11), 49.9 (C-3), 55.1 (C-19), 57.3 (C-2), 67.3 (C-12), 80.2 (C-8), 113.8 (C-15 and -17), 126.8 (C-13), 130.5 (C-14 and -18),

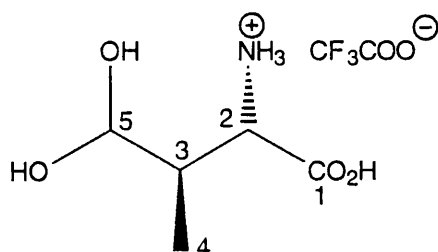
155.5 (C-16), 159.8 (C-7), 170.2 (C-1) and 201.9 (C-6); m/z 365 (M^+ , 1.1%), 308, 121 (100%) and 57 (found: M^+ , 365.1832. $C_{19}H_{27}NO_6$ requires M^+ , 365.1831).

p-Methoxybenzyl 2,3-dimethyl-*N*-(*t*-butoxycarbonylamino)aspartic Acid β -semialdehyde (178)



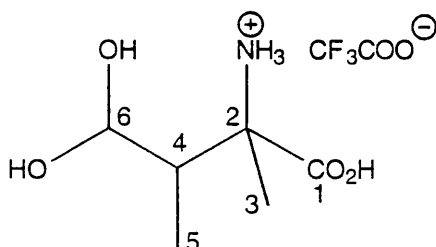
The title compound was prepared by saturating a solution of compound (175) (300 mg, 0.86 mmol) with ozone in accordance with general procedure 1. Triethylamine (0.17 g, 2 equiv.) was added to decompose the ozonide formed and the solution was allowed to warm up to room temperature overnight. The compound was purified by silica gel chromatography to give the title compound as a clear oil, 280 mg (93% yield); ν_{\max} 3510, 2985, 1745, 1718 and 1693 ($CHCl_3$) cm^{-1} ; δ_H (200 MHz) ($CDCl_3$) 1.2 (3H, d, J 7.3 Hz, 5- H_3), 1.4 and 1.5 (12H, 2xs, 3-, 9-, 10- and 11- H_3), 2.9 (1H, m, 4-CH), 3.6 (3H, s, 19- H_3), 4.9 (2H, s, 12- H_2), 6.8 (2H, m, 15- and 17- H), 7.3 (2H, m, 14- and 18- H) and 9.6 (1H, brs, 6- H); δ_C (50 MHz) ($CDCl_3$) 16.2 (C-5), 22.4 (C-3), 29.0 (C-9-, -10 and -11), 52.1 (C-4), 54.3 (C-19), 55.4 (C-2), 68.1 (C-12), 80.6 (C-8), 115.6, 128.1, 128.7 and 130.2 (aromatic carbons), 161.5 (C-7), 172.4 (C-1) and 201.5 (C-6); m/z 365 (M^+ , 0.8%), 308, 264, 121 and 57(100%) (found: M^+ , 365.1836. $C_{19}H_{27}NO_6$ requires M^+ , 365.1831).

Trifluoro acetate salt of β -Methylaspartic acid β -semialdehyde (179)



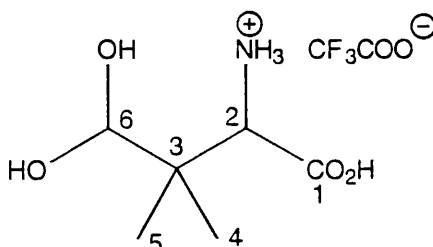
Compound (176) (100 mg, 0.28 mmol) was dissolved in anhydrous dichloromethane (5 ml) and was deprotected as for compound (23) to leave the title compound as a hygroscopic yellow solid, 45 mg (60% yield); δ_{H} (200 MHz) (CHCl_3) 1.1 (3H, d, 4-CH₃), 3.3 (1H, m, 3-H), 3.8 (1H, m, 2-H) and 4.9 (1H, m, 5-H); δ_{C} (50 MHz) (D_2O) 15.0 (C-4), 42.0 (C-3), 68.3 (C-2), 93.9 (C-5) and 174.6 (C-1); m/z 150 (M^+ , 1.3%) (found: M^+ , 150.0769. $\text{C}_5\text{H}_{12}\text{NO}_4$ requires M^+ , 150.0763).

Trifluoroacetate salt of $\alpha\beta$ -Dimethylaspartic acid β -semialdehyde (180)



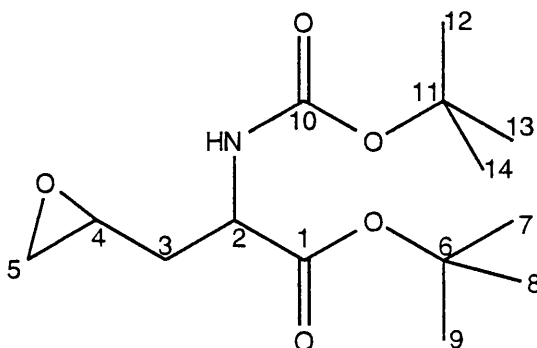
Compound (178) (100 mg, 0.5 mmol) was dissolved in anhydrous dichloromethane (5 ml) and was deprotected as for compound (23) to leave the title compound as a hygroscopic pale yellow solid, 75 mg (92% yield); δ_{H} (200 MHz) (CHCl_3) 1.2 (3H, s, 3-H₃), 1.5 (3H, m, 5-H₃), 3.2 (1H, m, 4-H) and 5.2 (1H, m, 6-H); δ_{C} (50 MHz) (CDCl_3) 19.5 (C-5), 24.2 (C-3), 56.2 (C-4), 61.5 (C-2), 99.1 (C-6) and 175.8 (C-1); m/z 164 (0.2%) (found: M^+ , 164.0926. $\text{C}_6\text{H}_{14}\text{NO}_4$ requires M^+ , 164.0919).

Trifluoroacetate salt of $\beta\beta$ -dimethylaspartic acid β -semialdehyde (181)



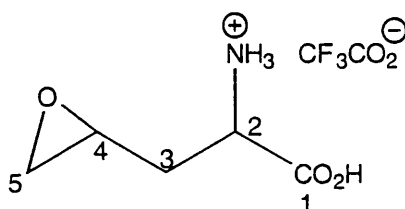
Compound (177) (100 mg, 0.5 mmol) was dissolved in anhydrous dichloromethane (5 ml) and was deprotected as for compound (23) to leave the title compound as a white solid, 75 mg (92% yield); δ_{H} (200 MHz) (CHCl_3) 1.1 (6H, s, 4- and 5-H₃), 3.8 (1H, m, 2-H) and 5.1 (1H, m, 6-H); δ_{C} (50 MHz) (CDCl_3) 19.4 and 20.1 (C-4 and -5), 51.2 (C-3), 58.4 (C-2), 95.3 (C-6) and 175.2 (C-1); m/z 164 (0.1%) and 120 (found: M^+ , 164.0925. $\text{C}_6\text{H}_{14}\text{NO}_4$ requires M^+ , 164.0919).

t-Butyl 2-(*t*-butoxycarbonylamino)-4-epoxypentanoate (182)



To a solution of compound (125) (1.0 g, 3.7 mmol) in anhydrous dichloromethane (30 ml) at 0 °C (ice/water bath) was added *meta*-chloroperbenzoic acid (0.7 g, 4.06 mmol). The solution was stirred for 2 h at 0 °C and then for a further 18 h at room temperature. The solution was diluted with dichloromethane and was washed with sodium bicarbonate solution (4x15 ml) and then saturated brine solution (2x20 ml). The organic layer was dried (Na₂SO₄), filtered and concentrated under reduced pressure to leave the title compound as a clear oil which was purified by silica gel chromatography to give the title compound as a clear oil, 0.95 g (90% yield); ν_{\max} 3500, 3430, 3020, 2985, 1715, 1500 and 910 (CHCl₃) cm⁻¹; δ_{H} (200 MHz) (CDCl₃) 1.4 and 1.5; (18H, s, 7-, 8-, 9-, 12-, 13- and 14-H₃), 1.9 (2H, m, 3-H₂), 2.5 (1H, m, 5-H), 2.7 (1H, m, 5-H), 3.0 (1H, m, 4-H), 4.4 (1H, m, 2-H) and 5.5 (1H, d, *J* 7.7 Hz, NH); δ_{C} (50 MHz) (CDCl₃) 27.6 and 28.0 (C-7, -8, -9, -11, -12 and -13), 35.3 (C-3), 46.2 (C-5), 48.8 (C-4), 52.1 (C-2), 79.3 (C-6), 81.7 (C-11), 155.0 (C-10) and 170.8 (C-1); *m/z* 216, 186, 160, 130, 116, 86, 57 (100%) and 41 (found: M-C₅H₁₁, 216.2084. C₉H₁₄NO₅ requires M-C₅H₁₁, 216.2076).

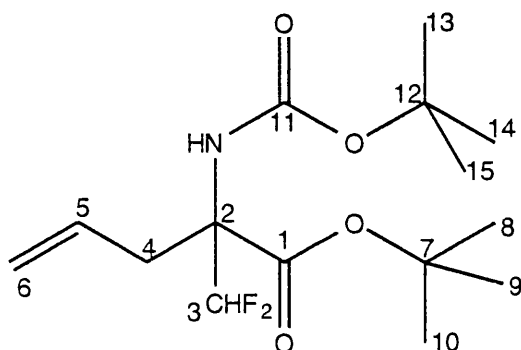
Trifluoroacetate salt of 2-amino-4-epoxypentanoate (183)



Compound (182) (100 mg, 0.35 mmol) was dissolved in anhydrous dichloromethane (5 ml) and was deprotected as for compound (23) to leave the title compound as a hygroscopic yellow solid, 54 mg (63% yield); ν_{\max} (CHCl₃) 3000, 2980, 1595, 1500 and 1240 cm⁻¹; δ_{H} (200 MHz) (D₂O) 2.10 (2H, m, 3-

H₂), 2.42 (1H, m, 5-H), 2.6 (1H, m, 5-H), 3.0 (1H, m, 4-H) and 4.35 (1H, m, 2-H); δ_C (50 MHz) (D₂O) 36.2 (C-3), 46.8 (C-5), 52.1 (C-4), 54.5 (C-2) and 174.5 (C-1); m/z 132 (M⁺, 1.2%), 114, 86, 74, 45 (100%) (found: M⁺, 132.0662. C₅H₁₀NO₃ requires M⁺, 132.0658).

Attempted preparation of *t*-Butyl *N*-(*t*-Butoxycarbonylamino)-2-difluoromethylallylglycine (184)



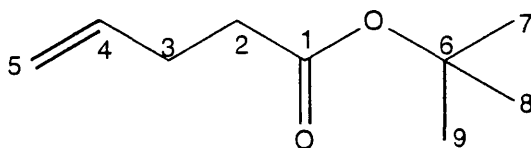
Method 1

To a solution of diisopropylamine (0.79 g, 2.1 equiv.) in anhydrous THF (10 ml) at -20 °C was added butyllithium (0.5 g, 2.1 equiv.), dropwise over a period of 15 min. This solution was stirred for a further 30 min at -20 °C before the temperature was lowered to -78 °C and the solution was diluted with anhydrous THF (35 ml). *N*-*t*-Butoxycarbonylallylglycine *t*-butyl ester (125) (1.0 g, 3.7 mmol) in anhydrous THF (25 ml) was added dropwise to the reaction over a period of 10 min. The solution turned a yellowish colour and was stirred at -78 °C for 20 min to allow complete generation of the anion. Chlorodifluoromethane was bubbled through the reaction until saturation point had been reached. The reaction mixture turned a dark red colour immediately upon addition of the gas. The mixture was kept at -78 °C for 3 h before being allowed to warm up to room temperature. The reaction was diluted with saturated ammonium chloride solution (20 ml) and then ether (30 ml) was added. Separation of the organic layer and further extraction of the aqueous layer with ether (2x25 ml) yielded organic extracts which were combined, dried (Na₂SO₄), filtered and concentrated *in vacuo* to afford an inseparable mixture of products which by NMR spectroscopy showed that no desired product had been formed.

Method 2

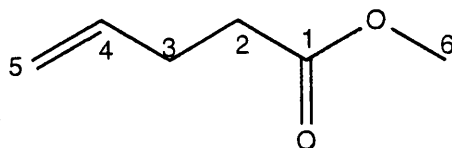
The above procedure was repeated using hexamethyldisilazane as the base, generated from hexamethyldisilane (1.0 g, 6.2 mmol) and butyllithium (0.5 g, 6.2 mmol). This was an attempt to reduce the formation of difluorocarbene. The reaction procedure was repeated as above. The instant darkening of the reaction was not seen but on work up and NMR spectroscopy there proved to be no product present.

4-Pentenoic Acid *t*-Butyl Ester (151)



To a solution of 4-pentenoic acid (0.5 g, 5 mmol) in dichloromethane (50 ml) at $-78\text{ }^{\circ}\text{C}$ was added, dropwise, via a dry-ice condenser, 2-methylpropene (10 ml). To the suspension was added concentrated sulfuric acid (1.5 ml). The suspension was then stirred for a further 8 h at $-78\text{ }^{\circ}\text{C}$ and then allowed to warm to room temperature overnight. The solution was concentrated *in vacuo* and partitioned between ethyl acetate and brine (1:1, 50 ml). The organic layer was separated and washed once more with brine (15 ml) before being dried (MgSO_4), filtered and concentrated under reduced pressure to leave the ester as a yellow oil 39 mg (5% yield); ν_{max} (CHCl_3) 2935, 1735, 1650 and 1390 cm^{-1} ; δ_{H} (200 MHz) (CDCl_3) 1.44 (9H, s, 7-, 8- and 9- H_3), 2.40 (4H, m, 2- and 3- H_2), 5.00 (2H, m, 5- H_2) and 5.95 (1H, m, 4- H); δ_{C} (50 MHz) (CDCl_3) 29.1 (C-7, -8 and -9), 29.0 (C-3), 34.6 (C-2), 80.0 (C-6), 115.1 (C-5), 136.8 (C-4) and 172.2 (C-1); m/z 156 (M^+ , 1.2%), 99, 57 (100%) and 55 (found: M^+ , 156.1150. $\text{C}_9\text{H}_{16}\text{O}_2$ requires M^+ , 156.1146).

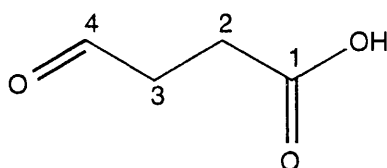
Preparation of methyl pent-4-enoate (152)



To a solution of pent-4-enoic acid (0.5 g, 5.0 mmol) in anhydrous methanol (30 ml) at $0\text{ }^{\circ}\text{C}$ was added, dropwise via a syringe pump, thionyl chloride (0.7 g, 1.2 equiv.). After the addition the flask was allowed to warm slowly to room temperature, stirring was stopped and the solution was left standing for a

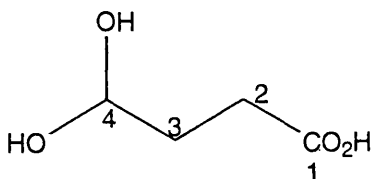
further 30 min. The solution was then concentrated under reduced pressure and partitioned between ethyl acetate (50 ml) and brine (50 ml). The organic layer was separated and the aqueous layer was further extracted with ethyl acetate (2x30 ml). The combined organic extracts were dried (MgSO₄), filtered, and the solvent was removed *in vacuo* to leave a clear oil, 57 mg (10% yield); ν_{\max} (CHCl₃) 3080, 2940, 1740 and 1650 cm⁻¹; δ_{H} (200 MHz) (CDCl₃) 2.38 (4H, m, 2- and 3-H₂), 3.65 (3H, s, 6-H₃) 5.00 (2H, m, 5-H₂) and 5.95 (1H, m, 4-H); δ_{C} (50 MHz) (CDCl₃) 28.8 (C-3), 35.1 (C-2), 58.0 (C-6) 115.6 (C-5), 136.0 (C-4) and 171.5 (C-1); m/z 114 (M⁺, 0.9%), 99, 74 (100%) and 55 (found: M⁺, 114.0675. C₆H₁₀O₂ requires M⁺, 114.0678).

Preparation of succinate semialdehyde (149)



The title compound was prepared by saturating a solution of pent-4-enoic acid (1.0 g, 10.0 mmol) with ozone in accordance with general procedure 1. Triethylamine (2.02 g, 2 equiv.) was added to decompose the ozonide formed and the solution was allowed to warm to room temperature overnight. The compound was purified by silica gel chromatography to yield the title compound as a clear oil, 0.5 g (50% yield); ν_{\max} (CHCl₃) 2950, 2826, 1730 and 1650 cm⁻¹; δ_{H} (200 MHz) (CD₃OD) 3.1-3.27 (2H, m, 3-H₂), 3.70-3.77 (2H, t, J 7.7 Hz, 2-H₂), 6.31-6.38 (0.99H, t, J 5.6 Hz, 4-H) 6.56 (2-H, brs, 2x4-OH) and 9.44 (0.5H, s, 4-H); δ_{C} (50 MHz) (CD₃OD) 30.7 (C-3), 33.9 (C-2), 99.6 (C-4) and 177.1 (C-1) (signals due to aldehyde 31.1 (C-3), 33.9 (C-3), 178.1 (C-1) and 201.7 (C-4); m/z 120 (M⁺, 3.4%), 102 (M⁺, 0.1%), 76, 58 and 44 (found: M⁺, 120.0423. C₄H₈O₄ requires M⁺, 120.0420).

succinate semialdehyde (154)

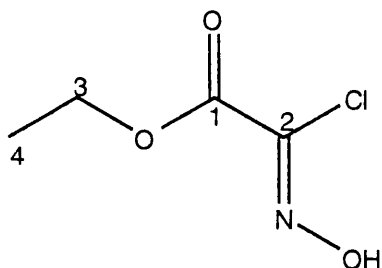


Compound (151) (100 mg, 0.5 mmol) was dissolved in anhydrous dichloromethane (5 ml) and was deprotected as for compound (23) to leave the title compound as a hygroscopic yellow solid, 75 mg (92% yield); The

compound isolated gave spectra identical to those detailed above for compound (149).

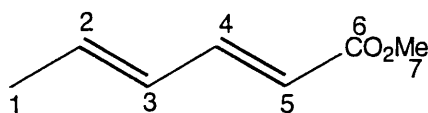
8.3: Experimental Detail for Chapter Four

Preparation of Ethyl Chlorooximidoacetate (192)¹⁸²



To a stirred solution of glycine ethyl ester hydrochloride (20 g, 14.3 mmol) in water (100 ml) at 0 °C (ice/water bath) was added, via a syringe pump, conc. hydrochloric acid (12 ml) over about 30 min. To the solution at 0 °C was added sodium nitrite (10 g) in water (15 ml), again via a syringe pump, over a period of 30 min. This procedure was repeated with a second addition of both components (amounts as for previous addition) and then the reaction was stirred for a further 2 h while being allowed to warm to room temperature. Saturated brine solution (25 ml) was added and the solution was extracted with ether (3x20 ml). The combined organic extracts were dried (Na₂SO₄), filtered and concentrated under reduced pressure to leave the title compound as a white solid, 10.9 g (50% yield) after recrystallisation from ether; mp 79-80 °C (lit.¹⁸³ 80 °C); ν_{\max} (KBr disc) 3317, 1750, 1618, 1310 cm⁻¹; δ_{H} (200 MHz) (CDCl₃) 1.40 (3H, t, *J* 7.1 Hz, 4-H₃), 4.4 (2H, q, *J* 7.1 Hz, 3-H₂) and 10.7 (1H, brs, OH); δ_{C} (50 MHz) (CDCl₃) 13.8 (C-4), 63.9 (C-3), 132.6 (C-2) and 159.8 (C-1); *m/z* 151 and 153 (M⁺, 1.0 and 0.3%), 136, 134, 125, 123, 108, 106, 70 (100%), 64, 63, 62, 61 and 54.

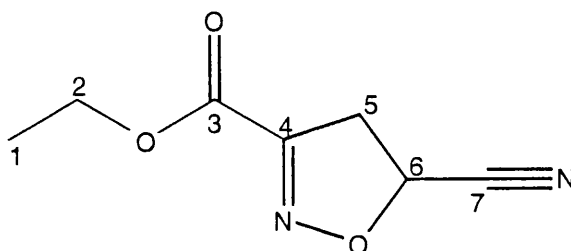
Preparation of methyl sorbate (209)



To a solution of sorbic acid (3 g, 26.8 mmol) in anhydrous methanol (30 ml) at 0 °C was added, dropwise via a syringe pump, thionyl chloride (2.4 ml, 1.2 equiv.). After the addition the flask was allowed to warm slowly to room

temperature, stirring was stopped and the solution was left standing for a further 30 min. The solution was then concentrated under reduced pressure and partitioned between ethyl acetate (50 ml) and brine (50 ml). The organic layer was separated and the aqueous layer was further extracted with ethyl acetate (2x30 ml). The combined organic extracts were dried (MgSO₄), filtered, and the solvent was removed *in vacuo* to leave a clear oil, 3.1 g (92% yield); δ_{H} (200 MHz) (CDCl₃) 1.8 (3H, d, *J* 5.3 Hz, 1-H₃), 3.7 (3H, s, 7-H₃), 5.8 (1H, d, *J* 15.4 Hz, 5-H), 6.2 (2H, m, 2- and 4-H) and 7.2 (1H, m, 3-H); δ_{C} (50 MHz) (CDCl₃) 18.6 (C-1), 51.4 (C-7), 118.6 (C-5), 129.8 (C-2), 139.4 (C-3), 145.2 (C-4) and 167.7 (C-6); *m/z* 126 (M⁺, 30.9%), 111, 95, 67 (100%), 52 and 41 (found M⁺ 126.0681. C₇H₁₀O₂ requires M⁺, 126.0678).

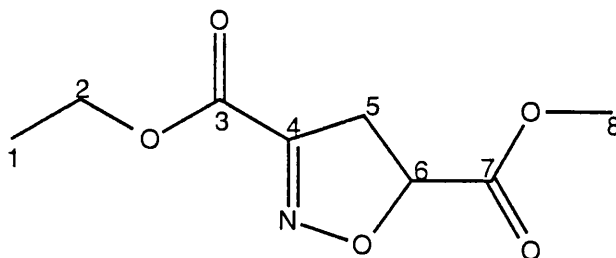
3-Ethoxycarbonyl-5-cyano-2-isoxazoline (197)



General Procedure 5

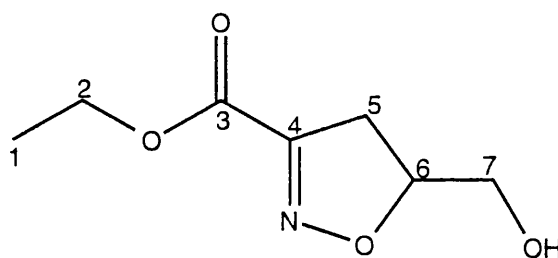
To a suspension of ethyl chlorooximidoacetate (192) (500 mg, 3.3 mmol) in ether (5 ml) was added with stirring, at room temperature, acrylonitrile (0.4 g, 3 equiv.). A syringe pump was used to add, dropwise, a solution of sodium carbonate (350 mg, 3.3 equiv.) in water (5 ml). After the addition was complete the solution was stoppered and stirred overnight. The organic layer was then separated and the aqueous layer was further extracted with ether (2x10 ml) and the combined organic extracts were dried (Na₂SO₄), filtered and concentrated under reduced pressure to leave an oil 500 mg (90% yield); ν_{max} (CHCl₃) 2920, 2245, 1710 and 1645 cm⁻¹; δ_{H} (200 MHz) (CDCl₃) 1.4 (3H, t, *J* 7.1 Hz, 1-H₃), 3.7 (2H, ABX, *J*_{AB} 18 Hz, 5-H₂), 4.4 (2H, q, *J* 7.1 Hz, 2-H₂) and 5.6 (1H, ABX, *J*_{AX} + *J*_{BX} 14.4 Hz); δ_{C} (50 MHz) (CDCl₃) 13.8 (C-1), 39.7 (C-5), 62.7 (C-2), 68.3 (C-6), 116.3 (C-7), 151.7 (C-4) and 158.8 (C-3); *m/z* 168 (M⁺, 3.4%), 142, 139, 123, 113, 95 and 69 (found: M⁺, 168.0531. C₇H₈N₂O₃ requires M⁺, 168.0533).

3-Ethoxycarbonyl-5-methoxycarbonyl-2-isoxazoline (198)



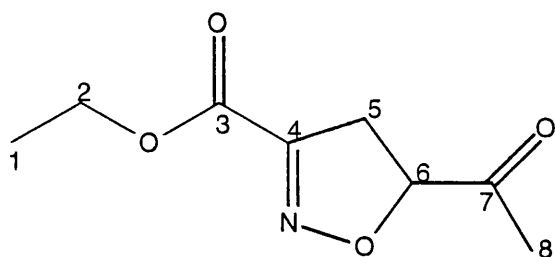
The title compound was prepared as for general procedure 5 with the following reagents. Ethyl chlorooximidoacetate (1 g, 6.6 mmol), methyl acrylate (5.7 g, 3 equiv.) and sodium carbonate (700 mg, 3.3 equiv.) were dissolved in a mixture of water and ether (1:1, 20 ml). The compound was isolated as an oil, 0.9g (68% yield); ν_{\max} (CHCl₃) 2937, 1749, 1720 and 1627 cm⁻¹; δ_{H} (200 MHz) (CDCl₃) 1.4 (3H, t, *J* 7.1 Hz, 1-H₃), 3.5 (2H, d, *J* 9.9 Hz, 5-H₂), 3.7 (3H, s, 8-H₃), 4.3 (2H, q, *J* 7.1 Hz, 2-H₂) and 5.3 (1H, t, *J* 9.6 Hz, 6-H); δ_{C} (50 MHz) (CDCl₃) 13.9 (C-1), 37.4 (C-5), 52.8 (C-8), 62.2 (C-2), 79.6 (C-6), 151.1 (C-4), 159.6 (C-6) and 169.3 (C-3); *m/z* 201 (M⁺, 1.4%), 156, 142 (100%), 114, 96 and 70 (found: M⁺, 201.0638. C₈H₁₁NO₅ requires M⁺, 201.0634).

3-Ethoxycarbonyl-5-hydroxymethyl-2-isoxazoline (201)



The title compound was prepared as for general procedure 5 with the following reagents. Ethyl chlorooximidoacetate (1 g, 6.6 mmol), allyl alcohol (1.13 g, 3 equiv.) and sodium carbonate (700 mg, 3.3 equiv.) were dissolved in a mixture of water and ether (1:1, 20 ml). The compound was isolated as an oil, 0.73g (64% yield); ν_{\max} (CHCl₃) 3375, 3016, 1739, 1710 and 1645 cm⁻¹; δ_{H} (200 MHz) (CDCl₃) 1.2 (3H, t, *J* 7.1 Hz, 1-H₃), 3.1 (2H, m, 5-H₂), 3.4-3.7 (3H, m, 7-H₂ and OH), 4.2 (2H, q, *J* 7.1, 2-H₂) and 4.7 (1H, m, 6-H); δ_{C} (50 MHz) (CDCl₃) 13.9 (C-1), 34.6 (C-5), 62.0 (C-7), 62.8 (C-2), 84.0 (C-6), 151.8 (C-4) and 160.4 (C-1); *m/z* 173 (M⁺, 1.8%), 142, 128, 114, 96 and 70 (100%) (found: M⁺, 173.0684. C₇H₁₁NO₄ requires M⁺, 173.0685).

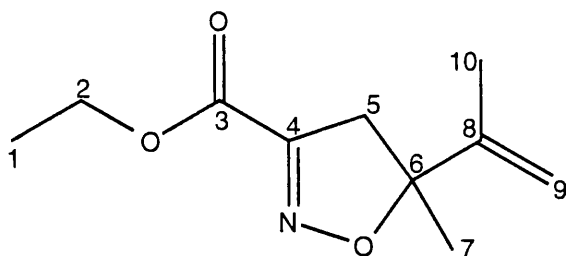
3-Ethoxycarbonyl-5-acetyl-2-isoxazoline (199)



The title compound was prepared as for general procedure 5 with the following reagents. Ethyl chlorooximidoacetate (1 g, 6.6 mmol), methylvinylketone (1.4 g, 3 equiv.) and sodium carbonate (700 mg, 3.3 equiv.) were dissolved in a mixture of water and ether (1:1, 20 ml). The compound was isolated as an oil, 1.05 g (86% yield); ν_{\max} (CHCl_3) 2937, 1749, 1720 and 1627 cm^{-1} ; δ_{H} (200 MHz) (CDCl_3) 1.2 (3H, t, J 7.1 Hz, 1- H_3), 2.1 (3H, s, 8- H_3), 3.3 (2H, ABX, 5- H_2), 4.1 (2H, q, J 7.1 Hz, 2- H_2) and 5.0 (1H, ABX, 6-H); δ_{C} (50 MHz) (CDCl_3) 14.1 (C-1), 26.4 (C-8), 35.8 (C-5), 62.3 (C-2), 86.1 (C-6), 151.7 (C-4), 159.8 (C-1) and 205.1 (C-7); m/z 185 (M^+ , 1.0%), 156, 142, 111, 96 and 70 (100%) (found: M^+ , 185.0690. $\text{C}_8\text{H}_{11}\text{NO}_4$ requires M^+ , 185.0685).

3-Ethoxycarbonyl-5-methyl-5-((2)-propenyl)-2-isoxazoline (211)

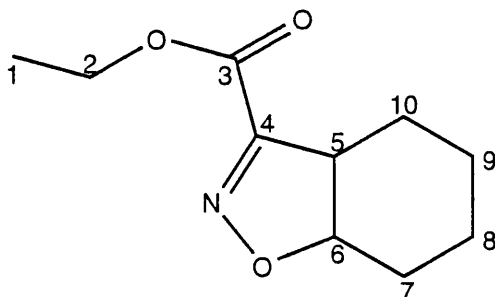
The title compound was prepared as for general procedure 5 with the following reagents. Ethyl chlorooximidoacetate (500 mg, 3.3 mmol), 2,3-dimethylbutadiene (0.81 g, 3 equiv.) and sodium carbonate (350 mg, 3.3 equiv.) were dissolved in a mixture of water and ether (1:1, 20 ml). The compound was isolated as an oil, 0.31 g (48% yield);



ν_{\max} (CHCl_3) 3050, 1745, and 1627 cm^{-1} ; δ_{H} (200 MHz) (CDCl_3) 1.0 (3H, t, J 7.1 Hz, 1- H_3), 1.2 (3H, s, 7- H_3), 1.5 (3H, brs, 10- H_3), 2.8 (2H, AB, J_{AB} 17.6 Hz, 5- H_2), 4.0 (2H, q, J 7.1 Hz, 2- H_2), 4.6 (1H, m, 9- H_2) and 4.8 (1H, brs, 9- H_2); δ_{C} (50 MHz) (CDCl_3) 13.5 (C-7), 17.8 (C-10), 24.5 (C-1), 43.2 (C-2), 61.2 (C-5), 91.3 (C-6), 110.8 (C-9), 144.8 (C-8), 150.1 (C-4) and 160.1 (C-3); m/z 197 (M^+ ,

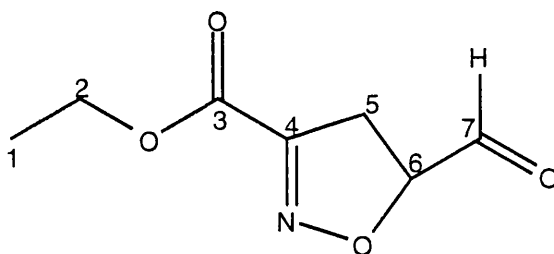
0.4%), 168, 129, 124, 114, 96 and 70 (found: M^+ , 197.2281. $C_{10}H_{15}NO_3$ requires M^+ , 197.2274).

3-Ethoxycarbonyl-4,5-tetramethylene-2-isoxazoline (203)



The title compound was prepared as for general procedure 5 with the following reagents. Ethyl chlorooximidoacetate (500 mg, 3.3 mmol), cyclohexene (0.81 g, 3 equiv.) and sodium carbonate (350 mg, 3.3 equiv.) were dissolved in a mixture of water and ether (1:1, 20 ml). The compound was isolated as an oil, 0.20 g (31% yield); ν_{\max} ($CHCl_3$) 2937, 1749, 1721 and 1627 cm^{-1} ; δ_H (200 MHz) ($CDCl_3$) 1.3 (3H, t, J 7.1, 1- H_3), 1.5-2.1 (8H, m, 7-, 8-, 9- and 10- H_2), 3.2 (1H, brq, J 7.8 Hz, 5-H) and 4.3-4.6 (3H, m, 2- H_2 and 6-H); δ_C (50 MHz) ($CDCl_3$) 13.9 (C-1), 19.6, 21.2, 24.6 and 25.4 (C-7, -8, -9 and -10), 43.3 (C-5), 61.7 (C-2), 82.5 (C-6), 155.0 (C-4) and 160.8 (C-3); m/z 197 (M^+ , 25.4%), 152, 141, 124 (100%), 106, 96 and 79 (found: M^+ , 197.2263. $C_{10}H_{15}NO_3$ requires M^+ , 197.2274).

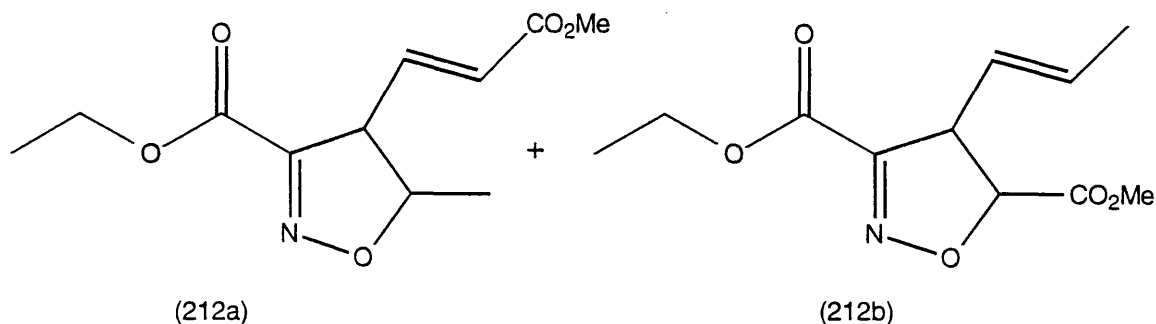
3-Ethoxycarbonyl-5-formyl-2-isoxazoline (200)



The title compound was prepared as for general procedure 5 with the following reagents. Ethyl chlorooximidoacetate (1 g, 6.6 mmol), acrolein (1.2 g, 3 equiv.) and sodium carbonate (700 mg, 3.3 equiv.) were dissolved in a mixture of water and ether (1:1, 20 ml). The compound was isolated as an oil, 56 mg (5% yield); ν_{\max} ($CHCl_3$) 2937, 1732, 1712 and 1635 cm^{-1} ; δ_H (200 MHz) ($CDCl_3$) 1.3 (3H, t, J 7.1 Hz, 1- H_3), 3.3 (2H, m, 5- H_2), 4.4 (2H, q, J 7.1 Hz, 2- H_2), 4.8 (0.75H, m, 7-H), 5.2 (1H, m, 6-H) and 9.7 (0.25H, s, 7-H); m/z 171 (M^+ , 0.1%),

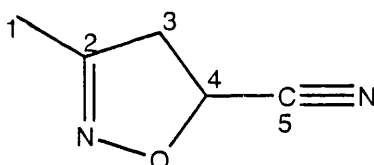
142 (100%), 113 and 70 (found: M^+ , 171.0533. $C_7H_9NO_4$ requires M^+ , 171.0529).

Attempted preparation of (212a) and (212b)



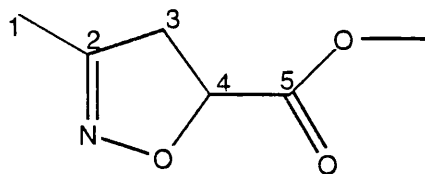
General procedure 5 was used with the following reagents. Ethyl chlorooximidoacetate (0.5 g, 3.3 mmol), methyl sorbate (209) (1.3 g, 3 equiv.), sodium carbonate (350 mg, 3.3 equiv.) were dissolved in a mixture of water and ether (1:1, 20 ml). The compound, which was isolated as an oil, upon NMR spectroscopic analysis was found to be the nitrile oxide dimer.

5-Cyano-3-methyl-2-isoxazoline (207)



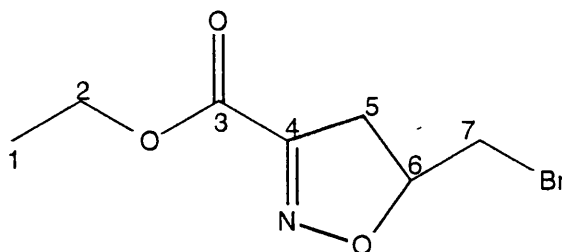
To a solution of nitroethane (0.75 g, 10 mmol), acrylonitrile (1.06 g, 20 mmol) and triethylamine (0.02 ml) in anhydrous benzene (50 ml) was added, dropwise, phenyl isocyanate (2.5 ml, 23 mmol) over a period of 2 h. Once the addition was complete the reaction was stirred at room temperature for a further 18 h. The resulting suspension was filtered, to remove precipitated diphenylurea, water (75 ml) was added and the biphasic mixture was stirred for 2 h at room temperature. The organic layer was then separated and the aqueous layer was further extracted with ether (2x15 ml). The combined organic extracts were dried ($MgSO_4$), filtered and concentrated *in vacuo* to leave the title compound as an oil which was purified by silica gel chromatography to leave 0.65 g (66% yield); ν_{max} ($CHCl_3$) 2994, 2247 and 1632 cm^{-1} ; δ_H (200 MHz) ($CDCl_3$) 2.0 (3H, s, 1- H_3), 3.4 (2H, ABX, 3- H_2) and 5.2 (1H, ABX, 4-H); δ_C (200 MHz) ($CDCl_3$) 12.3 (C-1), 44.4 (C-3), 65.8 (C-4), 117.6 (C-5) and 155.6 (C-2); m/z 110 (M^+ , 44.9%), 84, 80 and 57 (found: M^+ , 110.0472. $C_5H_6N_2O$ requires M^+ , 110.0479).

5-Methoxycarbonyl-3-methyl-2-isoxazoline (208)



To a solution of nitroethane (0.75 g, 10 mmol), methyl acrylate (1.72 g, 20 mmol) and triethylamine (0.02 ml) in anhydrous benzene (50 ml) was added, dropwise, phenyl isocyanate (2.5 ml, 23 mmol) over a period of 2 h. Once the addition was complete the reaction was stirred at room temperature for a further 18 h. The resulting suspension was filtered to remove precipitated diphenylurea and water (75 ml) was added and the biphasic mixture was stirred for 2 h at room temperature. The organic layer was then separated and the aqueous layer was further extracted with ether (2x15 ml). The combined organic extracts were dried (MgSO₄), filtered and concentrated *in vacuo* to leave the title compound as an oil which was purified by silica gel chromatography to leave 0.83 g (58% yield); ν_{\max} (CHCl₃) 3010, 1725 and 1642 cm⁻¹; δ_{H} (200 MHz) (CDCl₃) 1.9 (3H, s, 1-H₃), 3.3 (2H, ABX, 3-H₂), 3.7 (3H, s, 6-H₃), 5.0 (1H, ABX, 4-H); δ_{C} (200 MHz) (CD₃COCD₃) 12.3 (C-1), 42.3 (C-3), 52.5 (C-6), 77.6 (C-4), 155.5 (C-2) and 171.6 (C-5); m/z 143 (M⁺, 3.3%), 113, 84, 72 and 56 (100%) (found: M⁺, 143.0586. C₆H₉NO₃ requires M⁺, 143.0580).

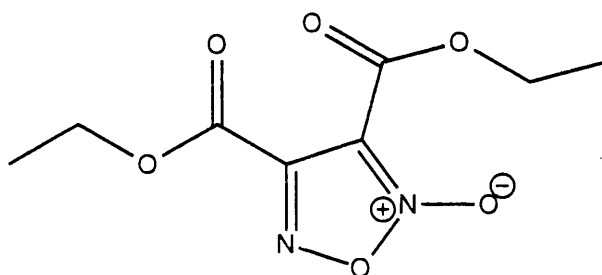
5-Bromomethyl-3-ethoxycarbonyl-2-isoxazoline (202)



The title compound was prepared as for general procedure 5 with the following reagents. Ethyl chlorooximidoacetate (1 g, 6.6 mmol), allyl bromide (2.4 g, 3 equiv.) and sodium carbonate (700 mg, 3.3 equiv.) were dissolved in a mixture of water and ether (1:1, 20 ml). The compound was isolated as an oil, 1.25 g (80% yield); ν_{\max} (CHCl₃) 2982, 1718, 1592, 1261 and 929 cm⁻¹; δ_{H} (200 MHz) (CDCl₃) 1.4 (3H, t, J 7.1 Hz, 1-H₃), 3.0-3.6 (4H, m, 5-H₂ and 7-H₂), 4.4 (2H, q, J 7.1 Hz, 2-H₂) and 5.1 (1H, m, 6-H); δ_{C} (50 MHz) (CDCl₃) 14.0 (C-1),

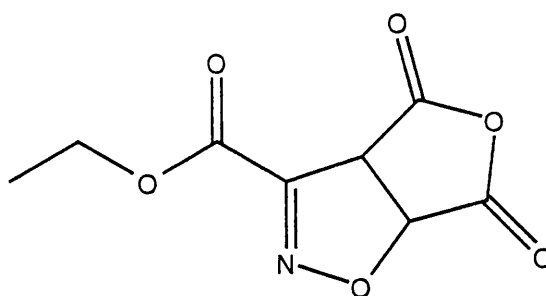
32.5 (C-7), 38.1 (C-5), 62.2 (C-2), 81.7 (C-6), 151.1 (C-4) and 160.2 (C-3); m/z 237 and 235 (M^+ , ^{79}Br 40.8% and ^{81}Br 39.2%), 209 and 207, 192 and 190, 142 (100%), 114 and 70 (found: M^+ , 236.9825 and 234.9840. $\text{C}_7\text{H}_{10}\text{NO}_3\text{Br}$ requires M^+ , 234.9847 (^{79}Br) and 236.9824 (^{81}Br)).

A second compound was isolated from this, and many of the other, reactions. It is a minor impurity and is formed by the dimerisation of the dipolar component (206). The compound was isolated by silica gel chromatography and is shown below together with its characterisation data.



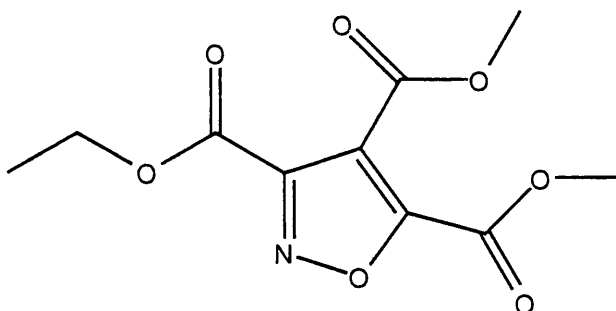
ν_{max} (CHCl_3) 2988, 1750, 1627, 1480, 1246 and 1066 cm^{-1} ; δ_{H} (200 MHz) (CDCl_3) 1.40 (3H, t, J 7.1 Hz, Me), 1.47 (3H, t, J 7.1 Hz, Me), 4.4 (2H, q, J 7.1 Hz, CH_2) and 4.6 (2H, q, J 7.1 Hz, CH_2); δ_{C} (50 MHz) (CDCl_3) 13.7 (Me), 65.6 (CH_2), 106.5 ($\text{C}=\text{N}-\text{O}^-$), 148.3 ($\text{C}=\text{N}$), 155.0 ($\text{C}=\text{O}$) and 156.6 ($\text{C}=\text{O}$); m/z 184 ($\text{M}-\text{C}_2\text{H}_6\text{O}$), 157, 112, 100, 84 and 53 (100%) (found $\text{M}-\text{C}_2\text{H}_6\text{O}$, 184.0114. $\text{C}_6\text{H}_4\text{N}_2\text{O}_5$ requires $\text{M}-\text{C}_2\text{H}_6\text{O}$, 184.0119).

Attempted preparation of 3-Ethoxycarbonyl-2-isoxazoline-4,5-dicarboxylic anhydride (204)



General procedure 5 was used with the following reagents. Ethyl chlorooximidoacetate (1.0 g, 6.6 mmol), maleic anhydride (2.4 g, 3 equiv.) and sodium carbonate (700 mg, 3.3 equiv.) were dissolved in a mixture of water and ether (1:1, 20 ml). The compound was isolated as an oil. By NMR analysis the compound was shown to be the dimer (206) as detailed above.

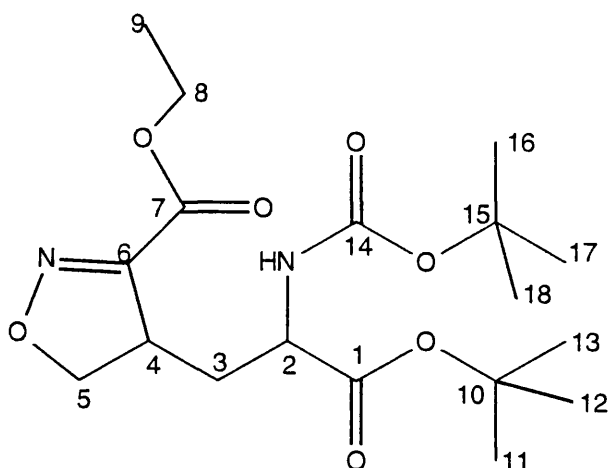
Attempted preparation of 3-Ethoxycarbonyl-2-isoxazole-4,5-dicarboxylic acid
(205)



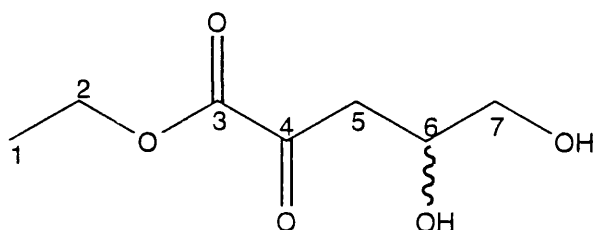
General procedure 5 was used with the following reagents. Ethyl chlorooximidoacetate (1.0 g, 6.6 mmol), dimethyl acetylenedicarboxylate (2.81 g, 3 equiv.) and sodium carbonate (700 mg, 3.3 equiv.) were dissolved in a mixture of water and ether (1:1, 20 ml). The compound was isolated as an oil, and by NMR spectroscopy was shown to be the dimer (206) as detailed above.

Preparation of 2-(*N*-(*t*-Butylcarbonylamino)-3-(3-*t*-butoxycarbonyl)-2-(isoxazolin-4-yl)propanoate (213)

The title compound was prepared as for general procedure 5 with the following reagents: ethyl chlorooximidoacetate (0.5 g, 3.3 mmol), *N*-(*t*-butoxycarbonyl)allylglycine-*t*-butyl ester (2.7 g, 3 equiv.) and sodium carbonate (350 mg, 3.3 equiv.) were dissolved in a mixture of water and ether (1:1, 20 ml). The title compound was isolated as an oil, 0.84 g (70% yield); ν_{\max} (CHCl₃) 3500-3250, 1719, 1523, 1441 cm⁻¹; δ_{H} (200 MHz) (CDCl₃) 1.32 (3H, q, J 7.7 Hz, 9-H₃), 1.54 (18H, 2xs, 12-, 13-, 14-, 16-, 17- and 18-H₃), 2.17 (2H, dd, J 6.0 and 6.0 Hz, 3-H₂), 2.9-3.4 (2H, ABX, J_{AB} 18.0 Hz, J_{AX} 7.5 Hz, J_{BX} 11.0 Hz, 5-H₂), 4.05 (2H, t, J 7.7 Hz, 8-H₂), 4.43 (1H, m, 2-H) and 4.89 (1H, m, 4-H); δ_{C} (50 MHz) (CDCl₃) 14.7 (C-9), 28.6 (C-12, -13, -14, -16, -17 and -18), 37.3 (C-3), 38.7 (C-5), 51.1 (C-2), 63.1 (C-8), 80.0 (C-4), 80.9 and 81.1 (C-11 and -15), 151.1 (C-6), 155.8 (C-10), 160.8 (C-7) and 171.6 (C-1); m/z (found M⁺, 364.1246. C₁₇H₂₀N₂O₇ requires M⁺, 364.1265).



Ethyl 4,5-dihydroxy-2-oxopentanoate (216)

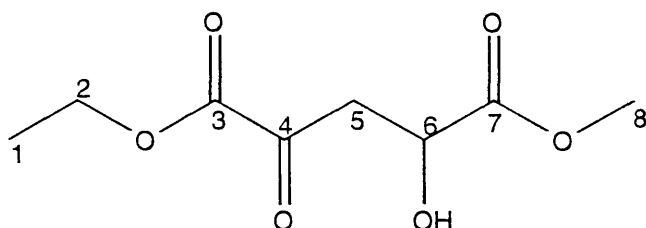


To a flame dried flask under a nitrogen atmosphere was added compound (201) (500 mg, 2.9 mmol), 10% palladium on carbon (approx. 20 mg), formic acid (0.7 ml, 4 equiv.) and anhydrous methanol (7 ml). The suspension was stirred at room temperature for 12 h. The spent palladium on carbon was removed by filtration through a celite pad. The celite pad was washed with methanol (2x10 ml) and removal of the solvent *in vacuo* left an orange oil. The oil was taken up in ether (5 ml) and 20% citric acid solution (5 ml) was added and the two phase mixture was stirred for 30 min. The organic layer was separated and the aqueous layer was further extracted with ether (2x5 ml). The combined organic extracts were dried (Na_2SO_4), filtered and concentrated under reduced pressure to leave (216), after silica gel chromatography, as a clear oil 45 mg (8.9% yield); ν_{max} (CHCl_3) 3450, 2926, 1745 and 1670 cm^{-1} ; δ_{H} (200 MHz) (CDCl_3) 1.4 (3H, t, J 7.1 Hz, 1- H_3), 3.5 (2H, m, 5- H_2), 3.9 (3H, m, 8- H_3), 4.4 (2H, q, J 7.1 Hz, 2- H_2), 5.4 (1H, m, 6- H) and 6.9 (1H, brs, 6- OH); m/z 204 (M^+ , 0.1%), 189, 175, 120, 76 and 53.

Ethyl 4-hydroxy-5-methyl-2-oxoglutarate (215)

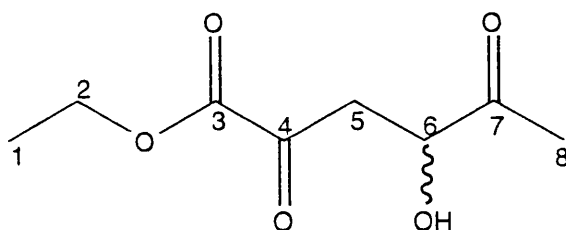
The title compound was prepared as detailed above with the following reagents. Compound (198) (255 mg, 1.27 mmol), ammonium formate (80 mg, 1 mmol), 10% palladium on carbon (aprox. 50 mg) and anhydrous methanol (10 ml) were

mixed and stirred overnight under a dry nitrogen atmosphere. Work up was as detailed above and after silica gel chromatography two clear oils were isolated,



(a) 57 mg (22% yield) and (b) 35 mg (13% yield); analysis for compound (a) showed it to be the starting material; ν_{\max} (CHCl_3) 2937, 1749, 1720 and 1627 cm^{-1} ; δ_{H} (200 MHz) (CDCl_3) 1.4 (3H, t, J 7.1 Hz, 1- H_3), 3.5 (2H, d, J 9.9 Hz, 5- H_2), 3.7 (3H, s, 8- H_3), 4.3 (2H, q, J 7.1 Hz, 2- H_2) and 5.3 (1H, t, J 9.6 Hz, 6-H); δ_{C} (50 MHz) (CDCl_3) 13.9 (C-1), 37.4 (C-5), 52.8 (C-8), 62.2 (C-2), 79.6 (C-6), 151.1 (C-4), 159.6 (C-6) and 169.3 (C-3); m/z 201 (M^+ , 1.4%), 156, 142 (100%), 114, 96 and 70 (found: M^+ , 201.0638. $\text{C}_8\text{H}_{11}\text{NO}_5$ requires M^+ , 201.1743); analysis for compound (b) showed it to be the title compound; ν_{\max} (CHCl_3) 3415, 2942, 1740 and 1685 cm^{-1} ; δ_{H} (200 MHz) (CDCl_3) 1.4 (3H, t, J 7.1 Hz, 1- H_3), 3.5 (2H, m, 5- H_2), 3.9 (3H, m, 8- H_3), 4.4 (2H, q, J 7.1 Hz, 2- H_2), 5.4 (1H, m, 6-H) and 6.9 (1H, brs, 6-OH); m/z 204 (M^+ , 0.1%), 189, 175, 120, 76 and 53.

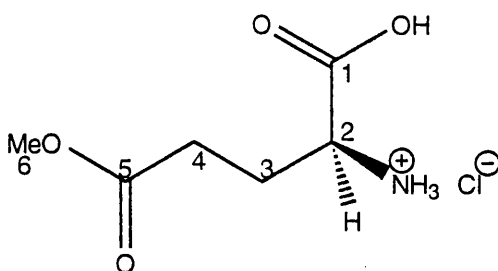
Ethyl 4-hydroxy-2,5-dioxohexanoate (214)



The title compound was prepared as detailed above with the following reagents. Compound (199) (150 mg, 0.81 mmol), ammonium formate (80 mg, 1 mmol), 10% palladium on carbon (aprox. 50 mg) and anhydrous methanol (10 ml) were mixed and stirred overnight under a dry nitrogen atmosphere. Work up was as detailed above and after silica gel chromatography a clear oil was isolated, 25 mg (16% yield); ν_{\max} (CHCl_3) 3395, 2942, 1750 and 1672 cm^{-1} ; δ_{H} (200 MHz) (CDCl_3) 1.26 (3H, t, J 7.2 Hz, 1- H_3), 2.05 (3H, s, 8- H_3), 3.71-3.85 (2H, m, 5- H_2), 4.14 (2H, q, J 7.2 Hz, 2- H_2), 4.15-4.45 (1H, m, 6-H) and 5.36 (1H, brs, 6-OH).

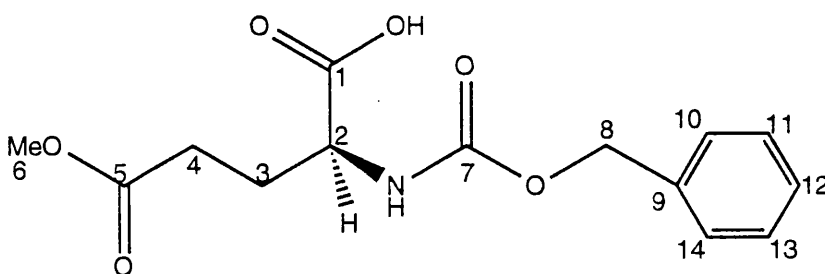
8.4: Experimental Detail for Chapter Five

δ -Methyl glutamate Hydrochloride (221)²⁰⁶



To a suspension of L-glutamic acid (10 g, 68.8 mmol) in anhydrous methanol (50 ml), at 0 C, was added thionyl chloride (10.9 g, 1.3 equiv.). After the addition the flask was allowed to warm to room temperature. Stirring was stopped and the flask was allowed to stand for 30 min. The solution was cooled to 0 C and ether (200 ml) was added. A short period later a white solid formed. The solid was filtered off and washed with ether (2x50 ml). The solid was dried under vacuum in a desiccator to remove any remaining water and sulfur dioxide. This left a white solid, 10.8 g (79% yield); ν_{max} (KBr disc) 3450, 2910, 1745 and 1715 cm^{-1} ; δ_{H} (200 MHz) (D_2O) 1.76 (2H, m, 3- H_2), 2.25 (2H, m, 4- H_2), 3.35 (3H, s, 6- H_3) and 3.38 (1H, m, 2-H); δ_{C} (50 MHz) (D_2O) 25.7 (C-3), 30.2 (C-4), 52.7 (C-2), 53.5 (C-6), 172.3 (C-5) and 175.7 (C-1); m/z 162 (MH^+ , 0.1%), 117, 116, 102, 84 (100%) and 56 (found MH^+ 162.0766. $\text{C}_6\text{H}_{12}\text{NO}_4$ requires MH^+ 162.0763).

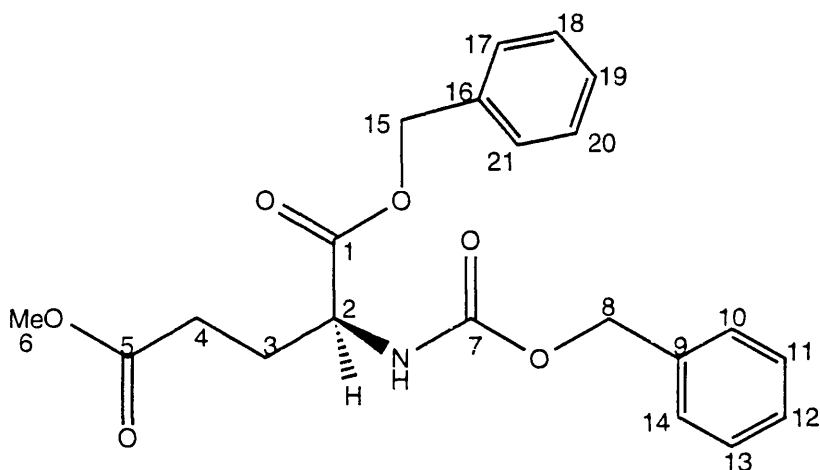
δ -Methyl *N*-(benzyloxycarbonyl)glutamate (222)²⁰⁶



To a solution of δ -methylglutamate hydrochloride (221) (10 g, 50.6 mmol) in water (95 ml) and 4M sodium hydroxide solution (13 ml) was added sodium bicarbonate (8.5 g, 2 equiv.). The solution was stirred at room temperature and benzyl chloroformate (10 ml, 1 equiv.) was added slowly over a period of 3 h. The solution was then stirred overnight, and washed with ether (2x50 ml) to remove any organic contaminants. The aqueous layer was acidified to pH 1, using 3M hydrochloric acid solution, and extracted with ether (3x50 ml). The

combined organic extracts were dried (Na_2SO_4), filtered and concentrated under reduced pressure to leave a clear green oil which was purified using silica gel chromatography to leave a clear oil, 11.5 g (77% yield); ν_{max} (CHCl_3) 3325, 2900, 1740 and 1720 cm^{-1} ; δ_{H} (200 MHz) (CDCl_3) 2.05 (2H, m, 3- H_2), 2.46 (2H, m, 4- H_2), 3.63 (3H, s, 6- H_3), 4.43 (1H, m, 2-H), 5.10 (2H, s, 8- H_2), 5.67 (1H, d, J 8.0 Hz, NH), 7.3 (5H, m, 10-, 11-, 12-, 13- and 14-H) and 9.99 (1H, brs, 1-OH); δ_{C} (50 MHz) (CDCl_3) 26.5 (C-3), 29.2 (C-4), 50.5 (C-6), 53.1 (C-2), 66.9 (C-8), 128.1, 128.2, 128.3, 128.5, 128.6, 135.1 (C-9, -10, -11, -12, -13 and -14), 156.0 (C-7), 171.7 (C-5) and 173.1 (C-1); m/z 295 (M^+ , 0.8%), 280, 251, 236, 221, 91 (100%) and 74 (found M^+ 295.1049. $\text{C}_{14}\text{H}_{17}\text{NO}_6$ requires M^+ , 295.1051).

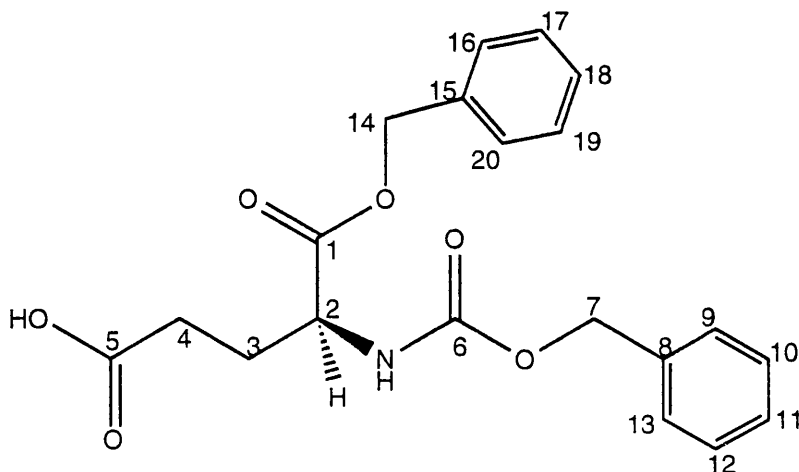
Benzyl δ -methyl *N*-(benzyloxycarbonyl)glutamate (223)



A solution of δ -methyl *N*-(benzyloxycarbonyl)glutamate (222) (580 mg, 1.97 mmol) in anhydrous dimethylformamide (10 ml) was prepared. To this solution was added benzyl bromide (336 mg, 1 equiv.) and sodium bicarbonate (182 mg, 1.1 equiv.). The solution was stirred at room temperature for 48 h and poured into saturated brine (20 ml) and ethyl acetate (20 ml). The organic layer was separated and washed again with brine (5x15 ml). The organic layer was then dried (MgSO_4), filtered and concentrated under reduced pressure to leave after silica gel chromatography, a clear oil, 381 mg (50% yield); δ_{H} (200 MHz) (CDCl_3) 1.9-2.5 (4H, m, 3- and 4- H_2), 3.6 (3H, s, 6- H_3), 4.43 (1H, m, 2-H), 5.08 (2H, s, 8- H_2), 5.14 (2H, s, 15- H_2), 5.6 (1H, brd, J 8.1 Hz, NH) and 7.32 (10H, m, 10-, 11-, 12-, 13-, 14-, 17-, 18-, 19-, 20- and 21-H); δ_{C} (50 MHz) (CDCl_3) 27.4 (C-3), 29.9 (C-4), 51.8 (C-6), 53.4 (C-2), 67.0, 67.3 (C-8 and -15), 128.0, 128.1, 128.2, 128.3, 128.5, 128.6, 135.1, 136.2 (C-9, -10, -11, -12, -13, -14, -16, -17, -18, -19, -20 and -21), 156.1 (C-7), 171.7 (C-1) and 173.1 (C-5); m/z 370 (M^+ -

CH₃, 1.5%), 326, 311,279, 91(100%), 74 (found M⁺-CH₃, 370.1280. C₂₁H₂₃NO₆ requires M⁺-CH₃, 370.1285).

Benzyl *N*-(benzyloxycarbonyl)glutamate (224)

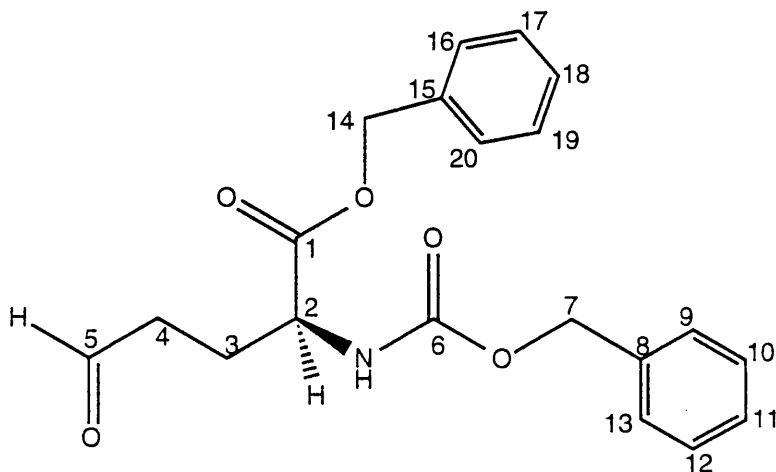


Benzyl δ -methyl *N*-(benzyloxycarbonyl)glutamate (223) (1.0 g, 2.6 mmol) was dissolved in methanol (5 ml) and to the solution was added 2M sodium hydroxide solution (7 ml). The solution was stirred vigorously for 2 h before being concentrated *in vacuo*. The residue was partitioned between ether (10 ml) and water (10 ml). The ether layer was separated and discarded. The remaining aqueous layer was acidified to pH 2 using 3M hydrochloric acid. The acidified solution was extracted with ethyl acetate (2x15 ml). The combined organic extracts were dried (Na₂SO₄), filtered and concentrated *in vacuo* to leave a clear oil, 0.88g (91% yield); ν_{\max} (CHCl₃) 3350, 2890, 1718 and 1515 cm⁻¹; δ_{H} (200 MHz) (CDCl₃) 1.7-2.1 (2H, m, 3-H₂), 2.2-2.3 (2H, m, 4-H₂), 4.2 (1H, m, 2-H), 4.9 (4H, brs, 7- and 14-H₂), 5.8 (1H, d, *J* 8.1 Hz, NH), 7.1 (10H, s, aromatic protons) and 10.1 (1H, brs, 5-OH); δ_{C} (50 MHz) (CDCl₃) 26.8 (C-3), 29.8 (C-4), 53.0 (C-2), 67.3 (C-7 and -14), 128.0, 128.1, 128.2, 128.5, 128.6, 134.5, 135.9 (aromatic carbons), 156.6 (C-6), 176.0 (C-1) and 178.1 (C-5); *m/z* 312 (M-C₂H₃O₂, 0.1%), 280, 249, 178, 108 and 91 (100%) (found: M-C₂H₃O₂, 312.1228. C₁₈H₁₈NO₄ requires M-C₂H₃O₂, 312.1231).

Attempted preparation of benzyl-*N*-(benzyloxycarbonyl)glutamic Acid γ -semialdehyde (225)

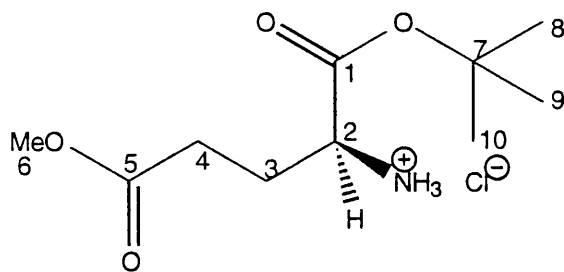
Benzyl *N*-(benzyloxycarbonyl)glutamate (224) (0.9 g, 2.43 mmol) was placed in a round bottomed flask equipped with a dry ice condenser. The flask and condenser were cooled to -78 C and methylamine (10 ml) was added via the

condensor. The solution was stirred at -78 C and lithium metal (0.18 g, 10 equiv.) was added in small pieces until the solution turned a blue colour. The remaining pieces of lithium were added over 40 min in order to keep the solution blue. Solid ammonium chloride (1 g) and then ice/concentrated



hydrochloric acid (13 g, 7ml) were added and the solution was extracted with ether (2x15 ml). The organic extracts were washed with sodium bicarbonate solution (10 ml), dried (Na_2SO_4), filtered and concentrated under reduced pressure to leave an inseparable mixture of products.

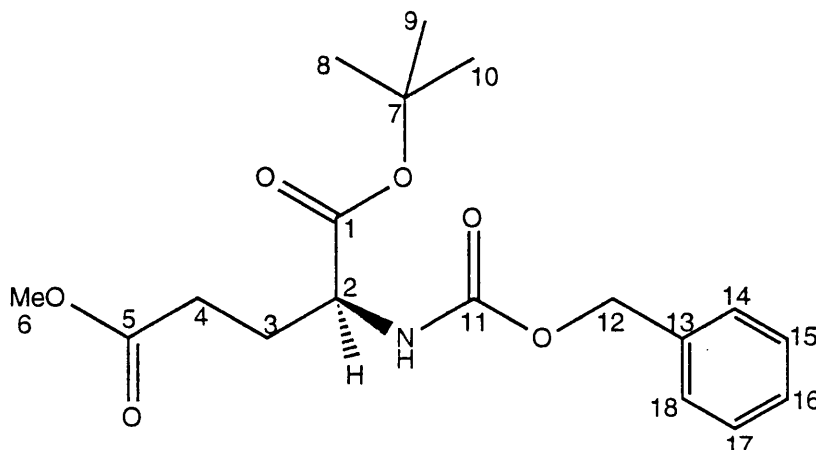
t-Butyl δ -methylglutamate hydrochloride (226)



To a solution of δ -methylglutamate hydrochloride (221) (1.0 g, 5.06 mmol) in anhydrous dichloromethane (50 ml), at -78 C, was added 2-methylpropene (15 ml) and conc. sulfuric acid (5 ml). The solution was stirred for 6 h at -78 C before being allowed to warm to room temperature overnight. The pH of the solution was adjusted to 9 by addition of saturated sodium bicarbonate solution. The aqueous layer was then extracted using ethyl acetate (3x50 ml). The organic layer was dried (MgSO_4), filtered and concentrated *in vacuo* to leave a yellow oil. The yellow oil was stirred and cooled to 0 C and upon the addition of ethereal HCl (75 ml) a white solid precipitated, 0.5 g (42% yield); δ_{H} (200 MHz) (D_2O) 1.37 (9H, s, 8-, 9- and 10- H_3), 2.11 (2H, q, J 7.1 Hz, 3- H_2), 2.51 (2H, m, 4- H_2), 3.59 (3H, s, 6- H_3) and 3.94 (1H, t, J 6.8 Hz, 2- H); δ_{C} (50 MHz)

(D₂O) 27.4 (C-3), 29.6 (C-8, -9 and -10), 31.9 (C-4), 55.1 (C-2), 59.3 (C-6), 88.5 (C-7), 171.0 (C-1) and 177.3 (C-5); *m/z* 218 (M⁺, .1%), 161, 117, 144, 74 and 57 (100%) (found M⁺, 218.1390. C₁₀H₂₀NO₄ requires M⁺, 218.1387).

t-Butyl δ -methyl *N*-(benzyloxycarbonylamino)glutamate (227)

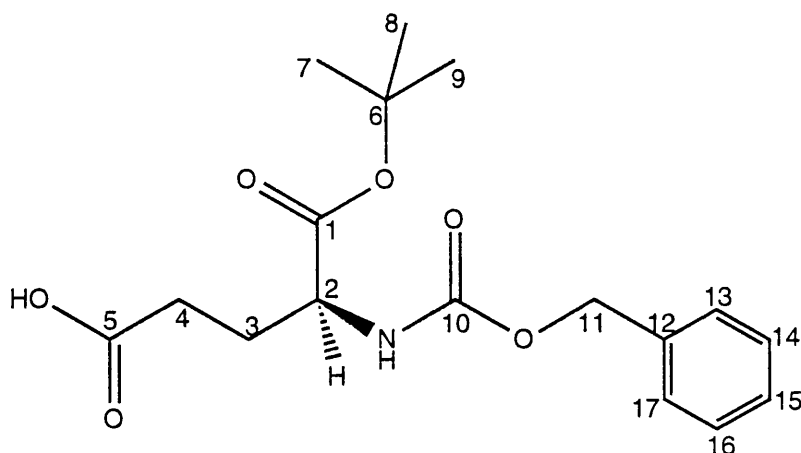


To a solution of compound (226) (3.0 g, 11.8 mmol) in water (95 ml) and 4M sodium hydroxide solution (13 ml) was added sodium bicarbonate (2.0 g, 23.6 mmol) and benzyl chloroformate (2.2 g, 13.0 mmol). The solution was stirred for 3 h before any organic impurities were removed by washing with ether (50 ml). The pH of the aqueous layer was adjusted to 2 using 3M HCl. The aqueous layer was then extracted with ethyl acetate (3x25 ml). The combined organic extracts were dried (Na₂SO₄), filtered and concentrated *in vacuo* to leave a clear oil, 3.36 g (81% yield); δ_{H} (200 MHz) (CDCl₃) 1.41 (9H, s, 8-, 9- and 10-H₃), 1.85-2.22 (2H, m, 3-H₂), 2.40 (2H, m, 4-H₂); 3.60 (3H, s, 6-H₃), 4.21 (1H, m, 2-H); 5.06 (2H, s, 12-H₂), 5.19 (1H, brd, NH) and 7.26 (5H, m, 14-, 15-, 16-, 17- and 18-H); δ_{C} (50 MHz) (CDCl₃) 27.8 (C-8, -9 and -10), 27.9 (C-3), 29.9 (C-4), 51.6 (C-6), 53.8 (C-2), 66.8 (C-12), 82.3 (C-7), 128.0, 128.4, 136.2 (C-13, -14, -15, -16, -17 and -18), 155.9 (C-11), 170.9 (C-1) and 173.1 (C-5); *m/z* 250 (M⁺-CO₂^tBu, 15.4%), 206, 174, 107 and 91 (100%) (found M⁺-CO₂^tBu, 250.1065. C₁₃H₁₆NO₄ requires M⁺-CO₂^tBu, 250.1075).

t-Butyl *N*-(benzyloxycarbonylamino)glutamate (228)

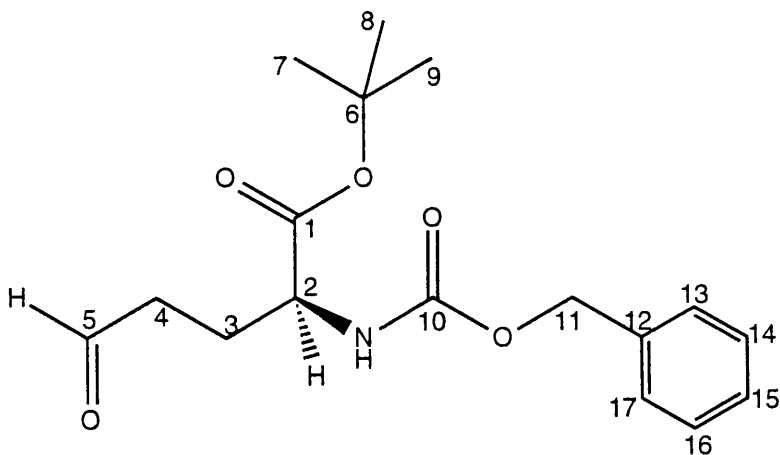
To a solution of compound (227) (2.0 g, 5.7 mmol) in methanol (10 ml) was added 2M sodium hydroxide (6 ml). The solution was stirred vigorously for 2 h before being concentrated. The residue was partitioned between water (10 ml) and ether (10 ml). The ether washings were discarded and the aqueous layer was acidified to pH 2. The acidified solution was then extracted using ethyl acetate (2x25 ml). The combined organic extracts were dried (Na₂SO₄),

filtered and concentrated *in vacuo* to leave a clear oil, 1.72 g (90% yield);



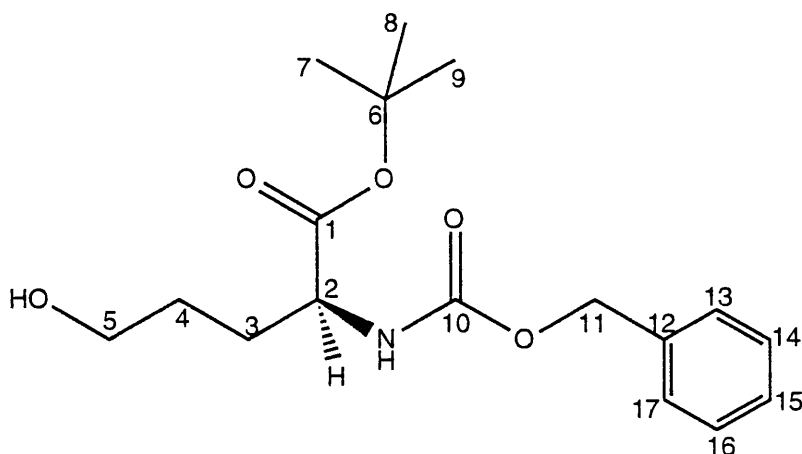
ν_{\max} (CHCl_3) 3250, 1740, 1710 and 1512 cm^{-1} ; δ_{H} (200 MHz) (CDCl_3) 1.45 (9H, s, 7-, 8- and 9- H_3), 1.93-2.42 (2H, m, 3- H_2), 2.41 (2H, m, 4- H_2), 4.44 (1H, m, 2-H), 5.09 (2H, s, 11- H_2), 5.82 (1H, d, J 8.0 Hz, NH), 7.27 (5H, m, 13-, 14-, 15-, 16- and 17-H) and 10.14 (1H, brs, 5-OH); δ_{C} (50 MHz) (CDCl_3) 27.0 (C-3), 27.8 (C-7, -8 and -9), 29.9 (C-4), 53.7 (C-2), 67.2 (C-11), 82.6 (C-6), 128.0, 128.1, 128.4, 136.2 (C-12, -13, -14, -15, -16 and -17), 156.3 (C-10), 171.5 (C-1) and 177.8 (C-5); m/z 281 ($\text{MH}^+ - t\text{Bu}$, 4.6%), 236, 192, 146, 108 and 91 (100%) (found: $\text{MH}^+ - t\text{Bu}$, 281.0901. $\text{C}_{13}\text{H}_{15}\text{NO}_6$ requires $\text{MH}^+ - t\text{Bu}$, 281.0895).

Attempted preparation of *t*-Butyl *N*-(benzyloxycarbonyl)glutamic acid γ -semialdehyde (225)



Compound (228) (0.96 g, 2.85 mmol) was reduced according to the procedure outlined for compound (225). The same work up was followed and isolation of any characterisable products was not achieved.

t-Butyl 2-(benzyloxycarbonylamino)-5-hydroxypentanoic acid (229)



Method 1

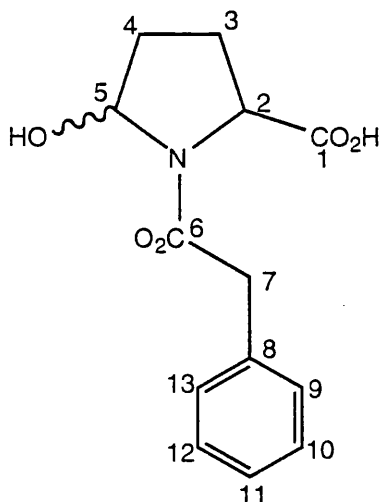
Compound (228) (150 mg, 0.4 mmol) was dissolved in anhydrous THF (10 ml). The solution was cooled to 0 C and stirred. Addition of borane/THF (0.7 ml, 0.7 mmol) or borane/dimethylsulfide (0.4ml, 0.7 ml) was carried out over 15 min. The resulting solution was then stirred for a further 3 h before being poured into methanol (5 ml) and stirred for 1 min. The solvent was removed under reduced pressure and the resulting residue partitioned between ethyl acetate (10 ml) and brine (10 ml). The organic layer was separated and the brine was extracted again with ethyl acetate (2x10 ml). The combined organic extracts were dried (Na₂SO₄), filtered and concentrated in vacuo to leave an oil, 135 mg (90% yield); ¹H and ¹³C NMR spectroscopy were identical to those recorded for the starting material.

Method 2

A solution of compound (223) (500 mg, 1.26 mmol) was dissolved in anhydrous THF (15 ml) and stirred at room temperature. To this solution was added lithium borohydride, as a powder, and the resulting suspension was heated at reflux (oil bath) for 4 h. Once the solution had cooled to room temperature saturated ammonium chloride solution (10 ml) was added. The reaction was diluted with ethyl acetate and the organic layer was separated and kept. Further extraction with ethyl acetate (2x10 ml), combination of the organic extracts, drying (Na₂SO₄), and removal of the solvent under reduced pressure gave the title compound as an oil, 244 mg (60% yield); δ_{H} (200 MHz) (CD₃OD) 1.4-1.9 (4H, m, 3- and 4-H₂), 3.5 (2H, m, 5-H₂), 4.6 (1H, brs, 2-H), 5.1 (2H, s, 14-H₂) and 7.3 (5H, m, 16-, 17-, 18-, 19- and 20-H); δ_{C} (50 MHz) (CD₃OD)

29.6 (C-3), 31.0 (C-4), 55.1 (C-2), 63.6 (C-5), 68.3 (C-14), 129.7, 129.9, 130.4, 139.0 (C-15, -16, -17, -18, -19 and -20) and 171.5 (C-1); m/z 222 ($M^+ - HCO_2$, 4.9%), 178, 91 (100%), 79 and 77 (found $M^+ - HCO_2$, 222.1130. $C_{12}H_{16}NO_3$ requires $M^+ - HCO_2$, 222.1126).

t-Butyl *N*-(benzyloxycarbonyl)glutamic Acid γ -semialdehyde (230)

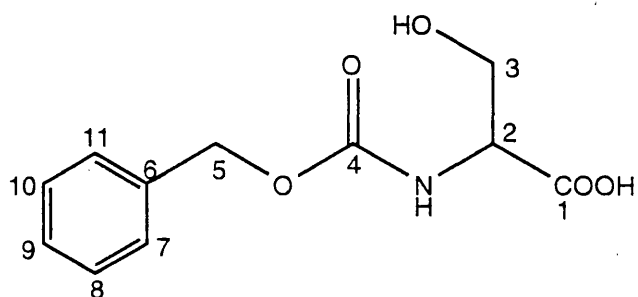


Compound 229 (100 mg, 0.3 mmol) was dissolved in anhydrous benzene (5 ml) with gentle warming. Dimethylsulfoxide (2.5 ml) was added to the solution with stirring. Anhydrous pyridine (24 mg, 0.3 mmol), anhydrous trifluoroacetic acid (17 mg, 0.15 mmol) and dicyclohexylcarbodiimide (185 mg, 0.9 mmol) were added to the solution with vigorous stirring. The flask was stoppered and stirred at room temperature for 18 h. Benzene (15 ml) was added and the precipitated dicyclohexylurea was filtered off and washed with benzene (2x5 ml). The combined filtrates were washed with water (3x10 ml). The organic layer was dried (Na_2SO_4), filtered and concentrated under reduced pressure to leave a pale brown oil, 41 mg (51% yield); ν_{max} 3590, 2980, 1735, 1680 and 1505 cm^{-1} ; δ_H (200 MHz) ($CDCl_3$) 1.8-2.35 (4H, brm, 3- and 4- H_2), 3.0-3.45 (1H, 2xbrd, OH), 4.1 (1H, brm, 2-H), 4.9 (2H, s, 7- H_2), 5.5 (1H, brm, 5-H) and 7.05-7.49 (5H, m, 8-13-H); δ_C (50 MHz) ($CDCl_3$) 30.9 and 32.2 (C-3 and -4), 59.5 and 60.1 (C-2), 65.8 (C-7), 82.0 and 82.7 (C-5), 128.1, 128.5, 129.4 and 137.6 (C-8-13), 150.5 (C-6) and 176.5 (C-1); m/z 222 ($M^+ - CO_2H$, 0.6%), 143, 129, 91 (100%), 79, 77 and 56.

N-(Benzyloxycarbonylamino)serine (237)²⁰⁰

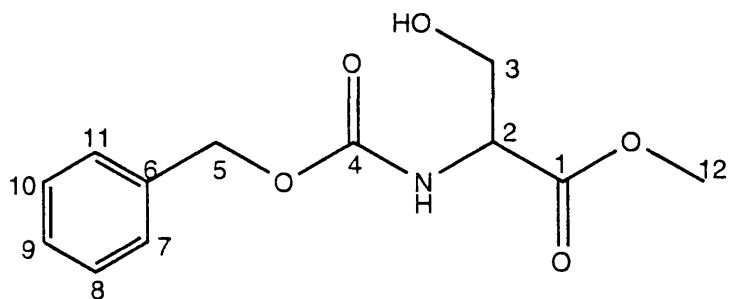
To a solution of L-serine (10.5 g, 100 mmol) in 1M sodium bicarbonate solution (400 ml) at room temperature was added benzyl chloroformate (24.0 g, 1.4 equiv.). After stirring for 4 h the aqueous layer was washed with ether (2x75

ml). The aqueous layer was cooled to -5 C (ice/water/salt bath) and was carefully acidified with conc. hydrochloric acid. The title compound precipitated and was filtered off and washed with water (2x25 ml). The combined filtrates were extracted with ethyl acetate (2x75 ml). The combined organic extracts were dried (Na₂SO₄), filtered and concentrated under reduced pressure to leave a white solid, which when combined with the precipitate gave the title compound, 23.03g (97.5% yield);



mp 118-119 C (lit.²⁰⁰ 117-119 C); δ_{H} (200 MHz) (D₂O) 3.6 (2H, m, 3-H₂), 4.0 (1H, m, 2-H), 4.9 (2H, s, 5-H₂) and 7.1 (5H, brs, 7-, 8-, 9-, 10- and 11-H); δ_{C} (50 MHz) (D₂O) 56.8 (C-2), 62.1 (C-3), 67.9 (C-5), 128.5, 129.1, 129.5, 137.0 (C-6, -7, -8, -9, -10 and -11) and 174.1 (C-1); m/z 239 (M⁺, 0.3%), 148, 131, 108, 91 (100%) and 77 (found M⁺, 239.0798. C₁₁H₁₃NO₅ requires M⁺, 239.0790).

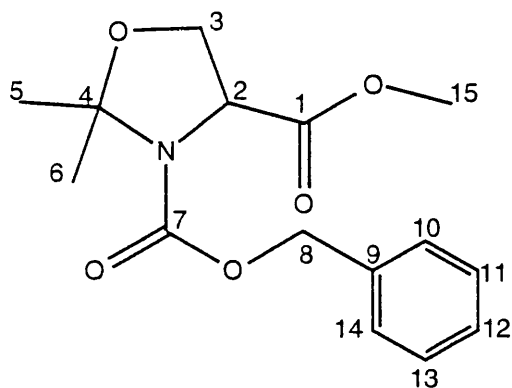
Methyl (2S)-2-(benzyloxycarbonylamino)-3-hydroxypropanoate (238)²⁰⁰



A stirred solution of compound (237) (5.0 g, 20.9 mmol) in anhydrous methanol (40 ml) was cooled to 0 C and thionyl chloride (2.3 ml, 1.5 equiv.) was added dropwise. The mixture was then stirred at 0 C for 30 min before being allowed to warm to room temperature. Stirring was continued for 18 h at room temperature before the solvent was removed under reduced pressure, to afford a crude oil which was partitioned between dichloromethane (50 ml) and saturated sodium bicarbonate solution (50 ml). The organic layer was separated and kept, the aqueous layer was back-extracted with dichloromethane (2x35 ml). The combined organic extracts were washed with

brine (30 ml), water (30 ml) and dried (Na_2SO_4). After filtration the solvent was removed under reduced pressure to afford an oil, which was purified using silica gel chromatography. The title compound was isolated as a clear oil, 5.13 g (97% yield); $[\alpha]_{\text{D}}^{20} +6.2$ (c 6.4, CHCl_3) {lit.,²⁰⁰ $[\alpha]_{\text{D}}^{23} +7.2$ (c 6.36 CHCl_3)}; ν_{max} (CHCl_3) 3400-3200, 3105, 2960 and 1725 cm^{-1} ; δ_{H} (200 MHz) (CDCl_3) 3.7 (3H, s, 12- H_3), 3.8-4.0 (2H, ABX, 3- H_2), 4.4 (1H, ABX, 2-H), 5.1 (2H, s, 5- H_2), 6.1 (1H, brd, J 8.1 Hz, NH) and 7.4 (5H, m, 7-, 8-, 9-, 10- and 11-H); δ_{C} (50 MHz) (CDCl_3) 52.6 (C-12), 56.1 (C-2), 62.8 (C-3), 67.1 (C-5), 128.0, 128.2, 128.5, 136.0 (C-6, -7, -8, -9, -10 and -11), 156.4 (C-4) and 171.3 (C-1); m/z 253 (M^+ , 3.4%), 223, 194, 162, 150, 108, 91 (100%) and 65 (found: M^+ , 253.0949. $\text{C}_{12}\text{H}_{15}\text{NO}_5$ requires M^+ , 253.0946).

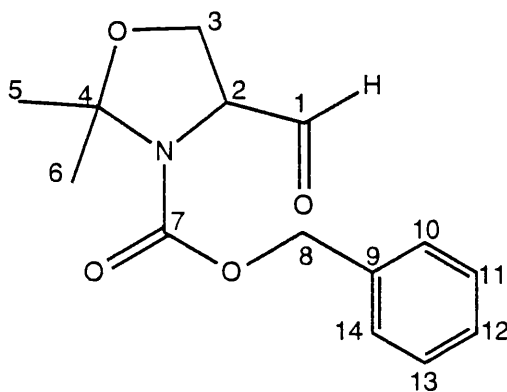
Methyl (4S)-3-benzyloxycarbonyl-2,2-dimethyloxazolidine-4-carboxylate (239)



A solution of compound (238) (500 mg, 1.98 mmol) in anhydrous benzene (30 ml) with 2,2-dimethoxypropane (0.35 ml, 1.5 equiv.) and *p*-toluenesulfonic acid (19 mg) was heated under Dean-Stark conditions for 1 h. The deep orange coloured reaction mixture was poured into saturated sodium bicarbonate solution (30 ml) and extracted with ether (3x40 ml). The combined organic extracts were washed with water (25 ml), dried (Na_2SO_4), filtered and concentrated to afford a crude oil, purification of which by silica gel chromatography gave the title compound as a clear oil, 468 mg (81% yield); $[\alpha]_{\text{D}}^{20} -52.2$ (c 1.3, CHCl_3) {lit.,²⁰⁰ $[\alpha]_{\text{D}}^{22} -52.1$ (c 1.31, CHCl_3)}; ν_{max} 3115, 3065, 2995, 1765, 1740 and 1715 cm^{-1} ; δ_{H} (200 MHz) (CDCl_3) 1.48 (1H, s, 5- or 6- H_3), 1.56 (2H, s, 5- or 6- H_3), 1.64 (1H, s, 5- or 6- H_3), 1.71 (2H, s, 5- or 6- H_3), 3.62 (2H, s, 15- H_3), 3.75 (1H, s, 15- H_3), 4.00-4.17 (2H, m, 3- H_2), 4.47-4.52 (0.71H, dd, J 6.5 and 2.9 Hz, 2-H), 4.52-4.60 (0.29H, dd, J 6.2 and 3.0 Hz, 2-H), 5.10 (1.33H, AB system, J 12.4 Hz, 8- H_2), 5.18 (0.67H, AB system, J 12.4 Hz, 8- H_2) and 7.45 (5H, m, 10-, 11-, 12-, 13- and 14-H); δ_{C} (50 MHz) (CDCl_3) 24.1, 25.0, 25.2, 26.0 (C-5 and -6), 52.4, 52.5 (C-15), 58.8, 59.5 (C-2), 66.2,

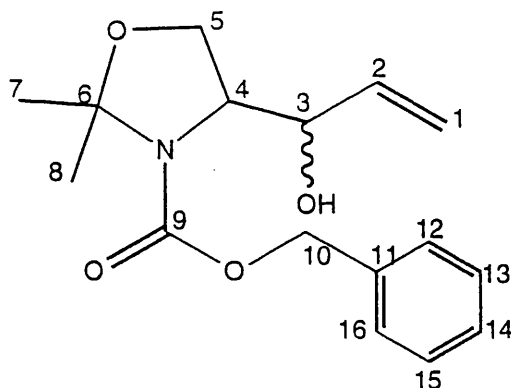
66.6, 66.7, 67.6 (C-3 and 8), 94.8, 95.4 (C-4), 127.7, 128.0, 128.2, 128.4, 128.6, 136.3 (C-9, -10, -11, -12, -13 and -14), 151.7 (C-7) and 171.2 (C-1); m/z 293 (M^+ , 1.0%), 278, 234, 190, 186, 128, 107, 91 (100%) and 65 (found: M^+ , 293.1254. $C_{15}H_{19}NO_5$ requires M^+ , 293.1258).

(4 S)-3-Benzoyloxycarbonyl 2,2-dimethyloxazolidine-4-carbaldehyde (240)



A stirred solution of compound (239) (250 mg, 0.85 mmol) in anhydrous toluene (20 ml) was cooled to $-78\text{ }^{\circ}\text{C}$ and diisobutylaluminium hydride (1.5M, 0.21 g, 1.7 equiv.) was added dropwise, keeping the internal temperature below $-70\text{ }^{\circ}\text{C}$. After the mixture had been stirred at $-78\text{ }^{\circ}\text{C}$ for a further 2 h, methanol (5 ml) was slowly added, and the internal temperature was kept below $-70\text{ }^{\circ}\text{C}$. The reaction mixture was poured into ice cold 1M HCl (10 ml) and extracted with ethyl acetate (3x20 ml). The combined organic extracts were washed with brine (20 ml), dried (Na_2SO_4), filtered and concentrated under reduced pressure to afford a crude oil. The compound was purified by silica gel chromatography to leave the title compound as a clear oil, 216 mg (97% yield); $[\alpha]_D^{20} +67.5$ (c 1.00, CHCl_3) {lit.,²⁰⁰ $[\alpha]_D^{25} +70$ (c 1.01, CHCl_3)}; ν_{max} 3120, 2995, 1740 and 1720 cm^{-1} ; δ_{H} (360 MHz) (CDCl_3) 1.50 (1.2H, s, 5- or 6- H_3), 1.57 (1.8H, s, 5- or 6- H_3), 1.59 (1.2H, s, 5- or 6- H_3), 1.67 (1.8H, s, 5- or 6- H_3), 3.91-4.75 (3H, m, 2-H and 3- H_2), 5.11-5.20 (2H, m, 8- H_2), 7.27-7.36 (5H, m, 10-, 11-, 12-, 13- and 14-H), 9.54 (0.6H, s, 1-H) and 9.6 (0.4H, s, 1-H); δ_{C} (50 MHz) (CDCl_3) 23.6, 24.7, 25.7, 26.6 (C-5 and -6), 63.6, 64.2, 64.5, 65.1, 67.2, 68.0 (C-2, -3 and -8), 94.8, 95.3 (C-4), 127.9, 128.1, 128.3, 128.6, 136.1 (C-9, -10, -11, -12, -13 and -14), 151.9 (C-7) and 199.0 (C-1); m/z 248 ($M^+ - \text{CH}_3$, 0.1%), 234, 190, 144, 108, 91 (100%) and 65 (found $M^+ - \text{CH}_3$, 248.0929. $C_{13}H_{14}NO_4$ requires $M^+ - \text{CH}_3$, 248.0919).

(4*S*)-3-Benzoyloxycarbonyl-4-[(1*R,S*)-1-hydroxyallyl]-2,2-dimethyloxazolidine
(241)

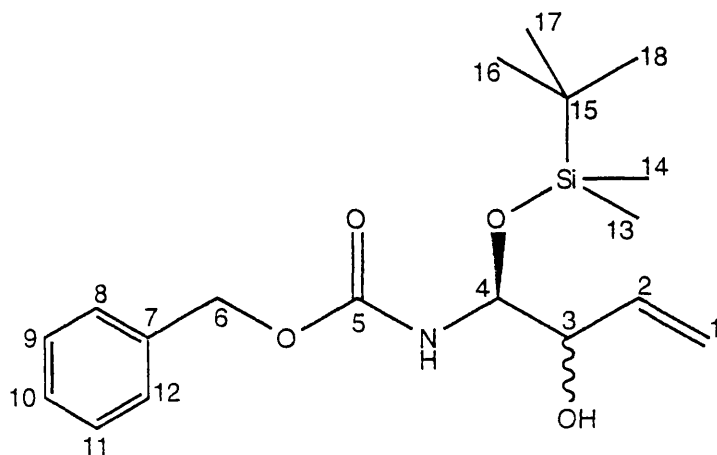


A solution of compound (240) (1.0 g, 3.8 mmol) in anhydrous THF (20 ml) was added dropwise over 30 min to vinylmagnesium bromide (1M solution, in THF, 7.6 ml, 2 equiv.) at -78 °C; the reaction was then quenched by slow addition of saturated ammonium chloride (5 ml). After this the reaction mixture was poured into saturated aqueous ammonium chloride (15 ml) and extracted with ether (3x25 ml). The combined organic extracts were washed with brine (30 ml), dried (MgSO₄), filtered and concentrated under reduced pressure to leave a crude oil. Purification by silica gel chromatography yielded the title compound as a clear oil, 1.01 g (91% yield); ν_{\max} (CHCl₃) 3590-3200, 3095, 1705 and 1670 cm⁻¹; δ_{H} (360 MHz) (CDCl₃) 1.42-1.66 (6H, m, 7- and 8-H₃), 3.90-4.13 (4H, m, 3-H, 4-H and 5-H₂), 5.09-5.20 (4H, m, 9-H₂ and 1-H₂), 5.72-5.96 (1H, m, 2H) and 7.24-7.34 (5H, m, 12-, 13-, 14-, 15- and 16-H); δ_{C} (50 MHz) (CDCl₃) 22.9, 24.6, 25.7, 26.3, 27.0 (C-7 and -8), 60.6, 62.2 (C-4), 64.6, 65.1, 67.2, 67.7 (C-5 and -10), 73.1, 73.6 (C-3), 94.8 (C-6), 116.4, 118.0 (C-1), 128.1, 128.2, 128.6 (C-2, -12, -13, -14, -15 and -16), 136.6, 137.5 (C-11) and 152.1 (C-9); m/z 234 (M⁺-C₃H₅O, 10.6%), 190, 144, 127, 108, 91 (100%) and 79 (found: M⁺-C₃H₅O, 234.1133. C₁₃H₁₆NO₃ requires M⁺-C₃H₅O, 234.1126).

(3*RS,4S*)-4-(Benzoyloxycarbonylamino)-5-[*t*-butyldimethylsiloxy]pent-1-en-3-ol
(242)

The oxazolidine (241) (600 mg, 2.75 mmol) was dissolved in anhydrous methanol (30 ml) and *p*-toluenesulfonic acid (100 mg) was added. The reaction mixture was stirred for 5 h at room temperature after which imidazole (1.4 g, 8 equiv.) was added and the solvent was removed under reduced pressure to afford a crude oil. The crude oil was redissolved in anhydrous DMF (25 ml) and *t*-butyldimethylsilyl chloride (382 mg, 1.2 equiv.) was added and the mixture was stirred overnight. The solution was poured into water (30 ml) and extracted

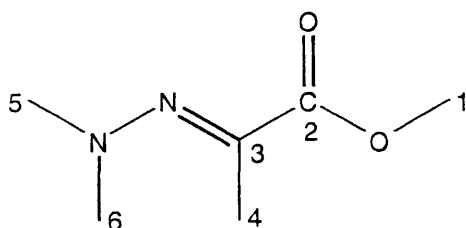
with dichloromethane (3x40 ml). The combined organic extracts were washed with saturated sodium bicarbonate solution (20 ml), dried (MgSO₄), filtered and concentrated under reduced pressure to leave an oil, which was purified by silica gel chromatography to afford an oil, 400 mg (57% yield);



ν_{\max} (CHCl₃) 3660-3300, 3095, 2955, 2855 and 1725 cm⁻¹; δ_{H} (200 MHz) (CDCl₃) 3.5-3.9 (4H, m, 4-H, 5-H₂ and OH), 4.3-4.5 (1H, m, 3-H), 5.0-5.4 (4H, m, 1- and 6-H₂), 5.7-6.0 (2H, m, 2-H and NH) and 7.3-7.4 (5H, m, 8-, 9-, 10-, 11- and 12-H); δ_{C} (50 MHz) (CDCl₃) 54.0 (C-4), 58.9, 60.2 (C-7), 65.3 (C-5), 70.3, 72.2 (C-3), 114.6, 115.0 (C-1), 126.3, 126.4, 126.5, 126.9, 135.7, 135.9 (C-7, -8, -9, -10, -11 and -12), 155.5 and 155.5 (C-5); m/z 308 (M⁺-^tBu, 1.6%), 250, 234, 177, 165, 91 and 75 (100%) (found: M⁺-^tBu, 308.1318. C₁₅H₂₂NO₄Si requires M⁺-^tBu, 308.1312).

8.5: Experimental Detail For Chapter Six

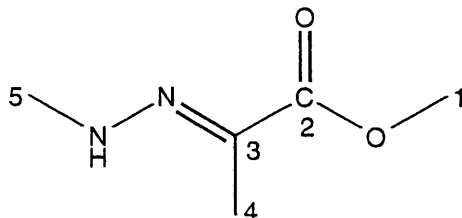
Methyl pyruvate dimethylhydrazone (247)



To a solution of methyl pyruvate (0.5 g, 5.7 mmol) in ethanol (25 ml) was added 1,1-dimethylhydrazine (0.58 g, 1.0 equiv). The solution was heated at reflux with stirring for 24 h. Once the solution had cooled the solvent was removed under reduced pressure to leave the title compound as a pale yellow solid, 0.58 (71% yield); δ_{H} (200 MHz) (CDCl₃) 1.98 (3H, s, 4-H₃), 2.69, 2.71 (6H, 2xs, 5- and 6-H₃), 3.67 (3H, s, 1-H₃); δ_{C} (50 MHz) (CDCl₃) 15.6 (C-4), 46.8 (C-5 and

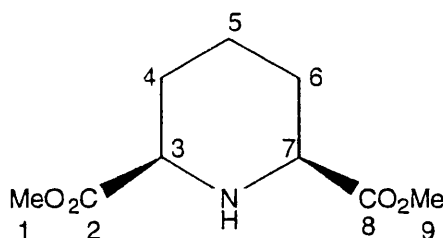
-6), 52.4 (C-1), 144.6 (C-3) and 165.6 (C-2); m/z 144 (M^+ , 5.1%), 129, 86 and 71 (found M^+ 144.0891. $C_6H_{12}N_2O_2$ requires M^+ 144.0896).

Methyl pyruvate methylhydrazone (248)



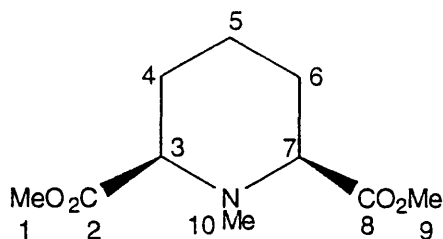
The title compound was prepared by the procedure detailed above for the dimethylhydrazone. Methyl pyruvate (0.5 g, 4.9 mmol) and methylhydrazine (0.37 g, 1.0 equiv.) were used to give the title compound as a white solid, 0.48 g (75% yield); δ_H (200 MHz) ($CDCl_3$) 1.86 (3H, s, 4- H_3), 3.1 (3H, s, 5- H_3), 3.73 (3H, s, 1- H_3) and 5.76 (1H, brs, NH); δ_C (50 MHz) ($CDCl_3$) 10.1 (C-4), 38.0 (C-5), 52.2 (C-1), 130.6 (C-3) and 165.7 (C-2); m/z 130 (M^+ , 1.0%), 115, 86 and 71 (found M^+ 130.0742. $C_5H_{10}N_2O_2$ requires M^+ 130.0740).

Dimethyl *cis*-piperidine-2,6-dicarboxylate (249)⁷⁶



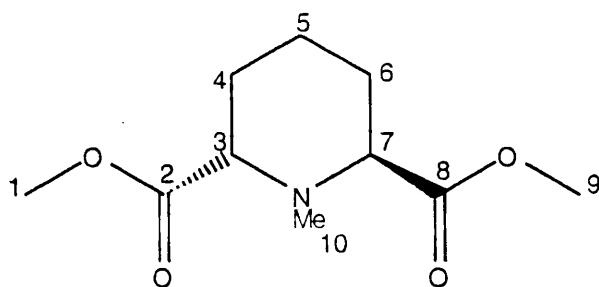
A solution of dimethyl dipicolinate (1.0 g, 5.1 mmol) in chloroform (20 ml) was hydrogenated at atmospheric pressure and room temperature for 24 h with PtO_2 (0.10 g) as catalyst. The catalyst was removed by filtration through Celite. The filtrate was concentrated to afford a white solid. Crystallisation from methanol gave dimethyl *cis* piperidine-2,6-dicarboxylate (249) as a white powder (0.94 g, 94%); mp 210 - 212 °C; ν_{max} 2990, 1740, 1320 and 1150 cm^{-1} ; δ_H (250 MHz) ($CDCl_3$) 1.38 - 1.83 (4H, m, 4- and 6- H_2), 2.40 (2H, m, 5- H_2) 3.80 (6H, s, 1- and 9- H_3) and 4.20 (2H, m, 3- and 7- H); m/z 201 (M^+ , 28%), 147 (42%) and 84 (100%) (Found: C, 53.78; H, 7.53; N, 6.96. $C_9H_{15}NO_4$ requires C, 53.77; H, 7.52; N, 6.96%).

Dimethyl *N*-methyl-*cis*-piperidine-2,6-dicarboxylate (250)⁷⁶



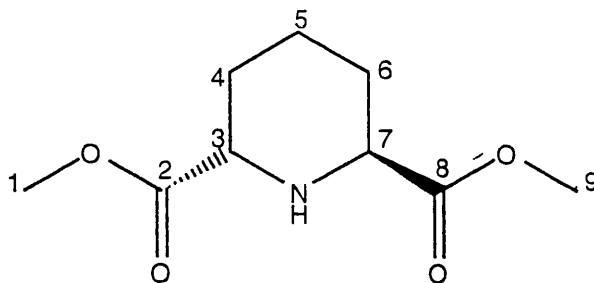
A mixture of *cis* piperidine-2,6-dicarboxylic acid hydrochloride (0.50 g, 2.9 mmol), 37% formaldehyde solution (0.48 g), 90% formic acid (0.60 ml) and sodium bicarbonate (0.25 g, 2.9 mmol) was heated at reflux for 17 h. Precipitated sodium chloride was filtered off and the filtrate was concentrated to an oil, 0.36 g, 75%; m.p. 212 - 216 C (lit.⁷⁶, 212 - 215 C), ν_{\max} 3450, 2990, 1740 and 1050 cm^{-1} ; δ_{H} (200 MHz) (CDCl_3) 1.75 - 1.82 (6H, 4-, 5- and 6- H_2), 3.10 (3H, s, 10- H_3), 3.75 (2H, m, 3- and 7-H) and 3.80 (6H, s, 1- and 9- H_3); δ_{C} (50 MHz) (CDCl_3) 22.01 (C-5), 28.41 (C-4 and -6), 42.95 (C-10), 53.2 (C-1 and -9), 69.24 (C-3 and -7) and 173.42 (C-1 and -9); m/z 187 (M^+ , 6%), 142 (42%) and 82 (100%) (Found: C, 42.90; H, 6.27; N, 6.27. $\text{C}_8\text{H}_{14}\text{O}_4\text{N}$ requires C, 42.90; H, 6.30; N, 6.26%).

Dimethyl *trans*-*N*-methylpiperidine-2,6-dicarboxylate (251)²⁰⁷



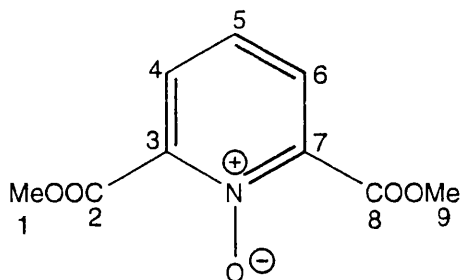
To a flame dried flask under a dry nitrogen atmosphere was added anhydrous methanol (10 ml). The flask was cooled to 0 C and acetyl chloride (0.5 ml, 2.3 equiv.) was added dropwise over 10 min. Upon warming to room temperature, *trans*-*N*-methylpipercolinic acid* (100 mg, 0.5 mmol) was added and the resulting solution was stirred for 30 min followed by heating at reflux for 16 h. After cooling to room temperature, the solvent was removed to leave a white solid, 90 mg (79% yield); ν_{\max} (KBr disc) cm^{-1} ; δ_{H} (200 MHz) (CDCl_3); δ_{C} (50 MHz) (CDCl_3); m/z 215 (M^+ , 0.2%), 201, 156, 142 (100%), 97, 83 and 70 (found M^+ , 215.1155. $\text{C}_{10}\text{H}_{17}\text{NO}_4$ requires M^+ , 215.1153).

Dimethyl *trans*-piperidine-2,6-dicarboxylate (252)²⁰⁷



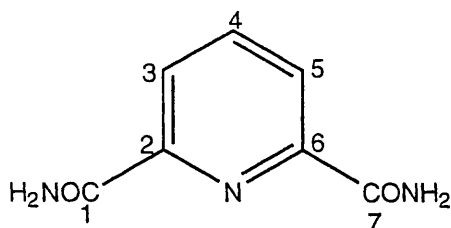
The title compound was prepared using the procedure detailed above for the preparation of the *N*-methyl analogue. *trans*-Pipicolinic acid (100 mg, 0.5 mmol), acetyl chloride (0.5 ml, 2.3 equiv.) and anhydrous methanol (10 ml) were reacted to give the title compound as a white solid, 80 mg (69% yield); ν_{\max} (KBr disc) cm^{-1} ; δ_{H} (200 MHz) (CDCl_3); δ_{C} (50 MHz) (CDCl_3); m/z 202 (MH^+ , 1.9%), 201, 143 (100%), 83, 82 and 55 (found MH^+ , 202.1067. $\text{C}_9\text{H}_{16}\text{NO}_4$ requires MH^+ , 202.1075).

Dimethyl pyridine-2,6-dicarboxylic acid *N*-oxide (253)⁷⁶



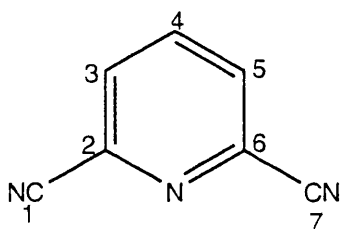
A modified version of the preparation reported by Couper *et al.*⁷⁶ was used to obtain the title compound. Dimethyl pyridine-2,6-dicarboxylate (1.31 g, 6.7 mmol) was dissolved in dichloromethane (25 ml). To the solution was added *meta*-chloroperbenzoic acid (1.93 g, 11.2 mmol). The solution was stirred at 0 °C for 5 h. The solution was washed with sodium bicarbonate solution (4x20 ml). The organic layer was dried (Na_2SO_4), filtered and concentrated under reduced pressure to leave the *N*-oxide, 1.1g (78% yield); δ_{H} (200 MHz) (CDCl_3) 4.03 (6H, s, 1- and 9-H3), 7.37-7.62 (1H, m, 5-H), 7.64-8.11 (2H, m, 4- and 6-H); δ_{C} (50 MHz) (CDCl_3) 52.1 (C-1 and -9), 128.0 (C-4 and -6), 138.4 (C-5), 148.0 (C-3 and -7) and 164.5 (C-2 and -8); m/z 211 (M^+ , 0.4%), 196, 181, 152, 94, 105, 77 and 51 (found M^+ , 211.0483. $\text{C}_9\text{H}_9\text{NO}_5$ requires M^+ , 211.0478).

Preparation of pyridine-2,6-dicarboxamide (254)⁷⁶



Pyridine-2,6-dicarboxylic acid (1.0 g, 6.0 mmol) was dissolved in thionyl chloride (15 ml) and was heated at reflux, with stirring, for 2 h. The solution was concentrated under reduced pressure and the residue kept. A solution of ether (50 ml) saturated with ammonia was prepared. The solution was cooled to 0 °C and the residue was carefully added to it. The amide was collected by filtration and was recrystallised from ethanol to leave the amide as a white solid, 0.65 g (66% yield); ν_{\max} 3400, 3100, 1670 and 1590 cm^{-1} δ_{H} (200 MHz) (CD_3COCD_3) 7.31 (1H, brs, 4-H), 7.72 (2H, m, 3- and 5-H) and 8.49 (1.4H, brs, NH_2); δ_{C} (50 MHz) (CD_3COCD_3) 114.6 (C-3 and -5), 129.6 (C-4), 139.4 (C-2 and -6) and 155.8 (C-1 and -7); m/z 165 (M^+ , 13.9%), 122, 105, 77, 50 and 44(100%) (found M^+ , 165.0540. $\text{C}_7\text{H}_7\text{N}_3\text{O}_2$ requires M^+ , 165.0537).

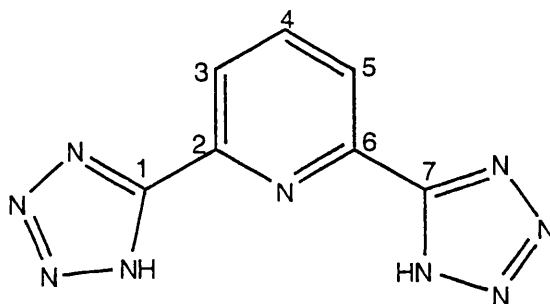
Pyridine-2,6-dinitrile (43)⁷⁶



A solution of compound (254) (1.0 g, 6.0 mmol) in toluene (20 ml) was heated in toluene at reflux. Phosphorus oxychloride was added over a period of 10 min and the mixture was heated at reflux for a further 30 min. The solution was decanted from the solid residue and concentrated *in vacuo*. Chloroform (20 ml) was added and the organic layer was washed with 10% sodium bicarbonate (3x20 ml) and then water (3x20 ml). The organic layer was dried (MgSO_4), filtered and concentrated under reduced pressure to leave after recrystallisation from chloroform, the title compound as a white solid, 78 mg (10% yield); mp 129-130 °C (lit.⁷⁶ 128-131 °C); ν_{\max} 2120, 1570 and 1450 cm^{-1} δ_{H} (200 MHz) (CDCl_3) 8.0 (2H, d, J 7.7 Hz, 3- and 5-H) and 8.1 (1H, dd, J 7.4 and 8.4 Hz, 4-H); δ_{C} (50 MHz) (CDCl_3) 115.5 (C-1 and -7), 131.3 (C-3 and -5), 135.1 (C-2

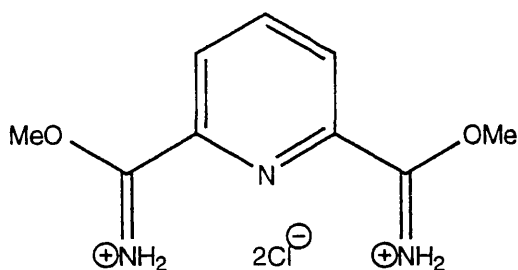
and -6) and 139.1 (C-4); m/z 129 (M^+ , 100%) and 103 (found M^+ , 129.0325. $C_7H_3N_3$ requires M^+ , 129.0327).

Pyridine-2,6-ditetrazole (41)⁷⁶



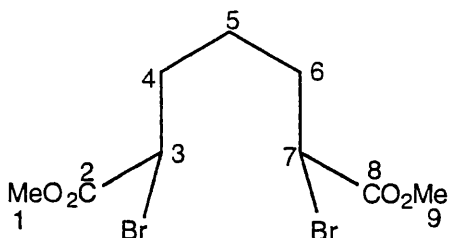
A mixture of pyridine-2,6-dinitrile (1.0 g, 7.7 mmol), sodium azide (1.16 g, 17.8 mmol) and ammonium chloride (0.82 g, 17.8 mmol) in dimethylformamide under a nitrogen atmosphere was heated at 70 °C for 24 h. The solution was cooled and added to diethyl ether (50 ml). The precipitate was filtered off, washed with ether (30 ml), and dried to give the title compound as a white solid, 1.5 g (90% yield); mp >300 °C (lit.⁷⁶ >300 °C); ν_{\max} 3000, 2500 and 1699 cm^{-1} , δ_H (200 MHz) (D_2O) 8.30 (3H, s, 3-, 4- and 5-H); δ_C (50 MHz) (D_2O) 122.6 (C-3 and -5), 139.6 (C-4), 1482 (C-2 and -6) and 162.5 (C-1 and -7); m/z 215 (M^+ , 24%) and 187 (100%) (found M^+ , 215.0672. $C_7H_5N_9$ requires M^+ , 215.0669).

Dimethyl pyridine-2,6-diimidate (42)⁷⁶



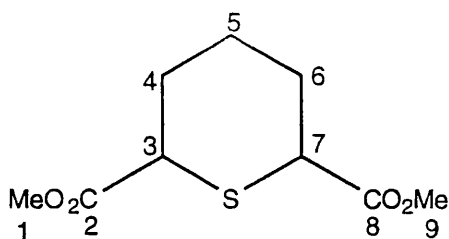
Dry hydrogen chloride gas was bubbled through a solution of pyridine-2,6-dinitrile (500 mg, 3.9 mmol) in anhydrous methanol (10 ml) at 0 °C. The white crystalline material produced was filtered off and dried. Recrystallisation from water gave dimethylpyridine-2,6-diimidate, 100 mg (10% yield); mp >300 °C (lit.⁷⁶ >300 °C); ν_{\max} 2960, 1660, 1590, 1310 and 1100 cm^{-1} ; δ_H (200 MHz) (D_2O) 7.34 (3H, m, 3-, 4- and 5-H); δ_C (50 MHz) (D_2O) 54.2 (C-8 and -9), 129.6 (C-4), 140.8 (C-3 and -5), 147.8 (C-2 and -6) and 166.5 (C-1 and -7); m/z 196 (M^+ , 4%), 165, 136 and 80 (100%).

Dimethyl 2,6-dibromopimelate (255)²⁰⁸



To a solution of pimelic acid (1.0 g, 5.7 mmol) in toluene (20 ml) was added thionyl chloride (1 ml, 12.4 mmol). The solution was heated at reflux for 2 h with stirring. To the solution at reflux was added bromine (0.7 ml) dropwise over 20 min. The solution was heated at reflux for a further 10 h. The solution was concentrated *in vacuo* to leave a residue which was poured carefully into methanol (10 ml) at 0 °C, with stirring. The solution was concentrated and the product isolated as an orange oil, 1.7 g (87% yield); δ_{H} (200 MHz) (CDCl_3) 1.2-1.7 (2H, m, 5- H_2), 2.0-2.2 (4H, m, 4- and 6- H_2), 3.8 (6H, s, 1- and 9- H_3) and 4.3 (2H, t, J 7.7 Hz, 3- and 7- H); δ_{C} (50 MHz) (CDCl_3) 25.0 (C-5), 33.8 (C-4 and -6), 45.0 (C-3 and -7), 53.0 (C-1 and -9) and 169.8 (C-2 and -8); m/z 318 ($\text{M}^+ - \text{C}_2\text{H}_6$, 0.8%), 316 ($\text{M}^+ - \text{C}_2\text{H}_6$, 9.6%), 314 ($\text{M}^+ - \text{C}_2\text{H}_6$, 20.1%), 235, 153 (100%), 125, 79 and 81 (found $\text{M}^+ - \text{C}_2\text{H}_6$ ($2 \times {}^{81}\text{Br}$), 317.8752. $\text{C}_7\text{H}_8\text{O}_4\text{Br}_2$ requires $\text{M}^+ - \text{C}_2\text{H}_6$, 317.8747).

Methyl thiinane-2,6-dicarboxylate (256)

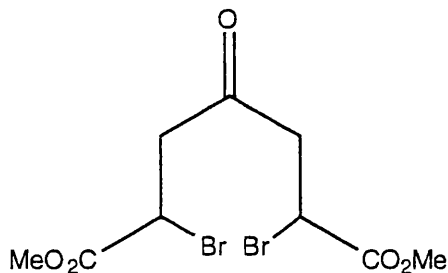


To a solution of compound (255) (4.0 g, 11.5 mmol) in dimethylformamide (15 ml) was added sodium sulfide (0.9 g, 1 equiv.). Water (3 ml) was added to dissolve the sulfide. The reaction was stirred for 3 h before the solution was concentrated *in vacuo*. The residue was partitioned between water (15 ml) and ethyl acetate (15 ml). The organic layer was further washed with brine (2x10 ml), dried (MgSO_4), filtered and concentrated under reduced pressure to leave the title compound as an oil, 1.2 g (48% yield); δ_{H} (200 MHz) (CDCl_3) 1.3-2.0

(6H, m, 4-, 5- and 6-H₂), 3.50 and 3.51 (6H, 2xs, 1- and 9-H₃) and 4.0 (2H, t, *J* 7.7 Hz, 3- and 7-H); δ_C (50 MHz) (CDCl₃) 24.6 (C-5), 29.4, 33.7 (C-4 and -6), 44.9 (C-3 and -7), 52.4, 52.8 (C-1 and -9) and 169.7 (C-2 and -8); *m/z* 218 (M⁺, 1.7 %), 159, 104, and 73 (100%) (found M⁺, 218.0619. C₉H₁₄O₄S requires M⁺, 218.0609).

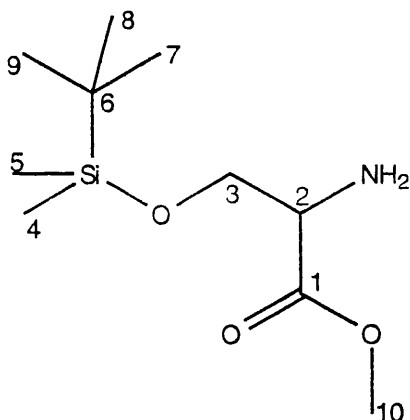
Attempted preparation of dimethyl 1,6-dibromohexan-4-one-1,6-dicarboxylate

(257)²⁰⁸



4-Oxopimelic acid (1.0 g, 5.7 mmol) was brominated under the same conditions used for the preparation of compound (255). The resulting brown oil, 1.5 g (72.5% yield) was purified by silica gel chromatography to leave a yellow oil 1.2 g (58% yield) which by ¹H and ¹³C NMR spectrometry was found to be not consistent with the desired structure.

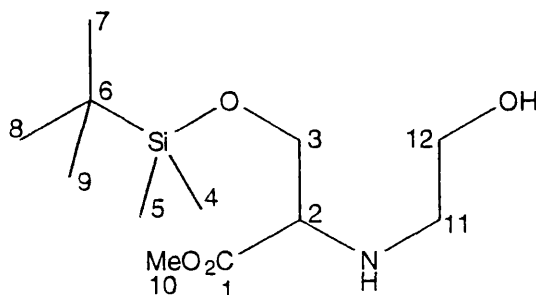
t-Butyldimethylsilyl serine methyl ester (259)



To a flame dried flask under a dry nitrogen atmosphere was added serine methyl ester (5 g, 32.1 mmol), imidazole (5.5 g, 2.5 equiv.) and anhydrous THF (50 ml). The mixture was stirred and cooled to 0 C. *tert*-Butyldimethylsilyl chloride (4.8 g, 1.0 equiv.) was dissolved in anhydrous THF (5 ml) and added dropwise to the reaction mixture. Stirring was continued for 1 h and imidazole hydrochloride was filtered off. The filtrate was washed with 10% citric acid solution (20 ml) and brine (20 ml) before being dried (Na₂SO₄), filtered and

concentrated *in vacuo* to leave the title compound as an oil, 6.5 g (98.5% yield); ν_{\max} 2915 and 1745 cm^{-1} ; δ_{H} (200 MHz) (CDCl_3) -0.3 and -0.1 (6H, s, 4- and 5- H_3), 0.85 (9H, s, 7-, 8- and 9- H_3), 3.5 (1H, ABX, $J_{\text{AX}+\text{BX}}$ 8.2 Hz, 2-H), 3.7 (3H, s, 10- H_3) and 3.7-4.0 (2H, ABX, J_{AB} 9.7 Hz, J_{AX} 4.4 Hz and J_{BX} 3.8 Hz, 3- H_2); δ_{C} (50 MHz) (CDCl_3) -5.7 and -5.6 (C-4 and -5), 18.0 (C-6), 25.6 (C-7, -8 and -9), 51.8 (C-2), 56.3 (C-10), 65.2 (C-3) and 174.4 (C-1); m/z 233 (M^+ , 0.1%), 218, 176, 116 (100%), 102, 89, 75 and 73 (found: M^+ , 233.1447. $\text{C}_{10}\text{H}_{23}\text{NO}_3\text{Si}$ requires M^+ , 233.1441).

N-(Hydroxyethyl)-*t*-butyldimethylsilyl serine methyl ester (260)

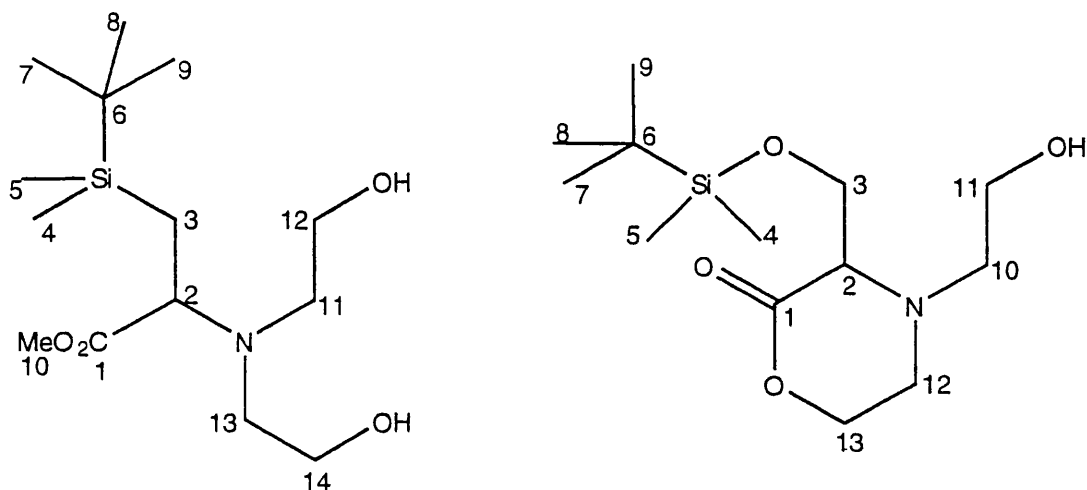


To a solution of compound (259) (3.0 g, 12.7 mmol) in water (25 ml) and ethanol (3 ml) at 0 $^{\circ}\text{C}$ was added ethylene oxide (3 ml, 4.0 equiv.). The reaction was stoppered and stirred for 1 h at 0 $^{\circ}\text{C}$. The solution was left to stand overnight at room temperature. Solvents were removed under reduced pressure to leave a clear oil, 2.99 g (85% yield). The product proved to be a mixture of compounds which were separated by silica gel chromatography; compound (260) was isolated from the column in 65% yield; ν_{\max} 3385, 2910 and 1748 cm^{-1} ; δ_{H} (200 MHz) (CDCl_3) 0.00 (6H, s, 4- and 5- H_3), 0.82 (9H, s, 7-, 8- and 9- H_3), 2.6-2.9 (4H, m, 11- and 12- H_2), 3.45 (1H, t, J 4.6 Hz, NH), 3.61 (1H, ABX, J 5.1 and 5.3 Hz, 2-H), 3.63 (3H, s, 10- H_3) and 3.7-3.9 (2H, ABX, 3- H_2); δ_{C} (50 MHz) (CDCl_3) -5.7 and -5.6 (C-5 and -5), 18.1 (C-6), 25.6 (C-7, -8, -9), 49.5 (C-12), 51.7 (C-10), 61.0 (C-11), 62.7 (C-2), 64.4 (C-3) and 173.6 (C-1); m/z 262 (M^+-CH_3 , 2.1%), 246, 220, 218, 188, 160, 132, 117 and 75 (100%) (found M^+-CH_3 , 262.1471. $\text{C}_{11}\text{H}_{24}\text{NO}_4\text{Si}$ requires M^+-CH_3 , 262.1468).

Two other compounds (263) (19% yield) and (264) (approximately 1% yield) were identified from the above reaction and are shown below:

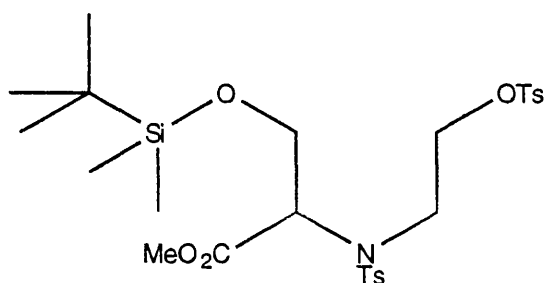
lactone (263): δ_{H} (200 MHz) (CDCl_3) 0.00 (6H, s, 4- and 5- H_3), 0.81 (9H, s, 7-, 8- and 9- H_3), 2.41 (1H, brs, OH), 2.60-2.77 (2H, m, 3- H_2), 3.05-3.11 (1H, m, 12- H_2), 3.33-3.98 (7H, m, 10-, 11-, 12- and 13- H_2), 4.03-4.37 (1H, m, 2-H); δ_{C} (50 MHz) (CDCl_3) -5.6 and -5.5 (C-4 and -5), 18.2 (C-6), 25.7 (C-7, -8 and -9),

46.8 (C-3), 56.2 and 58.5 (C-10 and -12), 63.7 and 67.9 (C-11 and -13), 66.8 (C-2) and 169.4 (C-1); m/z 288 ($M^+ - H$, 0.2%), 246, 230, 202, 101 and 75 (100%) (found $M^+ - H$, 288.1629. $C_{13}H_{26}NO_4Si$ requires $M^+ - H$, 288.1625).



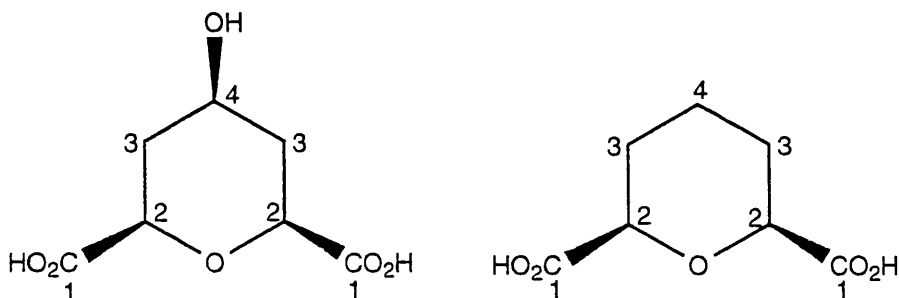
Di-alkylated compound (264) was observed by mass spectrometry of a crude sample from the reaction mixture. m/z 306 ($M^+ - CH_3$, 0.1%), 288, 246, 230, 202, 101 and 75 (100%) (found $M^+ - CH_3$, 306.1730. $C_{13}H_{28}NO_5Si$ requires $M^+ - CH_3$, 306.1729).

Attempted preparation of *NO*-di-*p*-toluenesulfonyl *N*-(hydroxyethyl)-*t*-butyldimethylsilyl serine methyl ester (261)



A solution of (260) (100 mg, 0.38 mmol) in dichloromethane (10 ml) was stirred at room temperature. To this was added tosyl chloride (0.15 g, 2.1 equiv.), 30% sodium hydroxide solution (10 ml) and benzyltriethylammonium chloride (10 mg). Vigorous stirring was continued for 4 h before the reaction mixture was poured into water (10 ml). The organic layer was separated and washed with water (3x10 ml). The organic layer was dried (Na_2SO_4), filtered and concentrated under reduced pressure to leave an oil, 50 mg (24% yield). NMR analysis showed that the products isolated were not of the structure expected for the product.

4-Hydroxytetrahydropyran-*cis*-2,6-dicarboxylic acid and tetrahydropyran-*cis*-2,6-dicarboxylic acid (262) and (263).



Method 1

To an oven dried flask under nitrogen was added chelidonic acid (1.0 g, 5.4 mmol). To this was added glacial acetic acid (10 ml) and platinum oxide (50 mg, 0.05 equiv.). The flask was evacuated briefly to remove any nitrogen gas and the vacuum was replaced with hydrogen gas from a balloon on the flask. The reaction mixture was stirred for 2 d under the hydrogen atmosphere before the spent platinum oxide was removed by filtration through a celite pad. The pad was washed with methanol (3x10 ml) and the filtrate was concentrated under reduced pressure to leave a sticky white solid, 450 mg (50% yield).

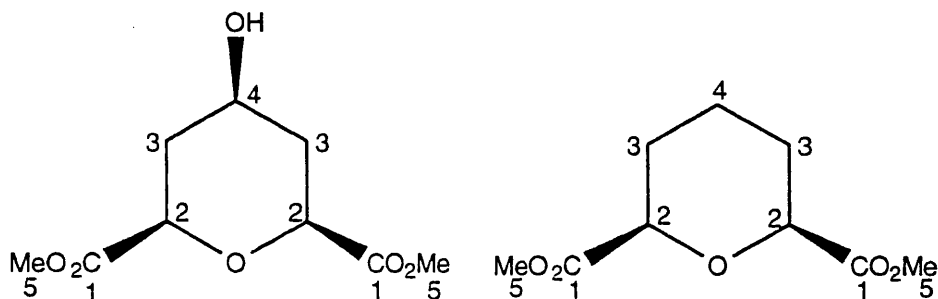
Method 2

To a flame dried flask under a nitrogen atmosphere was added chelidonic acid (1.0 g, 5.4 mmol), 10% palladium on carbon (approx. 20 mg), formic acid (1.0 g, 4 equiv.) and anhydrous methanol (7 ml). The suspension was stirred at room temperature for 12 h. The spent palladium on carbon was removed by filtration through a celite pad. The celite pad was washed with methanol (2x10 ml) and removal of the solvent *in vacuo* left a white solid which turned sticky immediately on exposure to air, 400 mg (44% yield).

Data for compound (262) and (263): compounds were inseparable at this point. Both reactions gave the same products with only the ratio of hydroxy to deshydroxy varying slightly; δ_{H} (200 MHz) (CDCl_3); for compound (263) δ_{C} (50 MHz) (CDCl_3) 23.2 (C-4), 28.3 (C-3), 76.2 (C-2) and 174.8 (C-1) and for compound (262) 37.3 (C-3), 66.8 (C-4), 74.4 (C-2) and 174.7 (C-1); m/z 129

(M^+ -(OH)CO₂H, 66.3%), 112, 101, 83 and 73 (100%) (found M^+ -(OH)CO₂H, 129.0551. C₆H₉O₃ requires M^+ -(OH)CO₂H, 129.0549).

Dimethyl 4-hydroxytetrahydropyran-*cis*-2,6-dicarboxylate (265) and dimethyl tetrahydropyran-*cis*-2,6-dicarboxylate (264).



Compounds (262) and (263) (500 mg, 2.63 mmol) were dissolved in anhydrous methanol (15 ml) with stirring. The solution was cooled to 0 °C and thionyl chloride (1.25 g, 4 equiv.) was added dropwise over a period of 10 min. The solution was stirred for a further 30 min at 0 °C before being left to stand for 2 h. The solvent was removed *in vacuo* and the residue was partitioned between ethyl acetate (20 ml) and brine (15 ml). The organic layer was separated and washed with brine (2x15 ml), dried (Na₂SO₄), filtered and concentrated under reduced pressure to leave a clear oil, 350 mg (61% yield). Purification by silica gel chromatography gave the two compounds as their dimethyl esters; compound (264) (45% yield): ν_{\max} 1739 and 1165 cm⁻¹; δ_{H} (200 MHz) (CDCl₃) 1.40-2.05 (6H, m, 3- and 4-H₂), 3.71 (6H, s, 5-H₃) and 4.0-4.12 (2H, m, 2-H); δ_{C} (50 MHz) (CDCl₃) 22.7 (C-4), 27.8 (C-3), 52.4 (C-5), 76.4 (C-2) and 170.7 (C-1); m/z 202 (M^+ , 6.4%), 187 (100%), 172, 143, 128 and 84 (found M^+ 202.0833. C₉H₁₄O₅ requires M^+ 202.0837). Compound (265) (16% yield): ν_{\max} 3450, 1742 and 1162 cm⁻¹; δ_{H} (200 MHz) (CDCl₃) 1.42-2.05 (4H, m, 3-H), 2.22-2.30 (1H, m, 4-H), 3.71 (6H, s, 5-H₃) and 4.00-4.08 (2H, m, 2-H); δ_{C} (50 MHz) (CDCl₃) 36.9 (C-3), 52.3 (C-5), 66.5 (C-4), 74.5 (C-2) and 170.1 (C-1); m/z 218 (M^+ , 1.7%), 203 (100%), 188, 144 and 100 (found M^+ 218.0790. C₉H₁₄O₆ requires M^+ 218.0786).

References

1. J. P. Greenstein and M. Winitz, '*Chemistry of the amino acids*', 1961, Vol. 1-3, John Wiley, New York.
2. H. B. Vickery, *Adv. Protein Chem.*, 1972, **26**, 82.
3. A. Meister, '*Biochemistry of the amino acids*', 1965, Vol. 1, 2nd edition, Academic Press, New York.
4. H. C. Steinruken and N. Amrhein, *Biochem. Biophys. Res. Commun.*, 1980, **94**, 1207.
5. J. L. Rubin, C. G. Gaines and R. A. Jensen, *Plant Physiol.*, 1982, **70**, 833.
6. J. L. Hilton, P. C. Kearney and B. N. Ames, *Arch. Biochem. Biophys.*, 1965, **112**, 544.
7. G. Levitt, H. L. Ploeg, R. C. Weigel and D. J. Fitzgerald, *J. Agric. Food Chem.*, 1981, **29**, 416.
8. A. Kleeman, W. Leuchtenberger, B. Hoppe and H. Tanner in '*Ullmann's Encyclopedia of Industrial Chemistry*', 1985, Vol. A2, 57.
9. W. R. Mills, P. J. Lea and B. J. Milfin, *Plant Physiol.*, 1980, **65**, 1166.
10. J. M. Ghuyssen in '*Topics in Antibiotic Chemistry*', (P. G. Sammes, Ed.), 1980, Vol. 5, Ellis Horwood Ltd., Chichester, U.K.
11. A. B. Watson, A. M. Brown, I. J. Colquhoun, N. J. Walton and D. J. Robins, *J. Chem. Soc., Perkin Trans. 1*, 1990, 2607.
12. M. P. Lamber and F. C. Neuhaus, *J. Bacteriol.*, 1972, **110**, 978.
13. D. J. Robins, *Chem. Soc. Rev.*, 1989, **18**, 375.
14. G. Bellavita, *Farm. Sci. Tech.*, 1948, **3**, 424.
15. D. Aragona, *Bull. Chim. Farm.*, 1948, **87**, 240.
16. T. Nakano, A. C. Spinelli and A. M. Mendez, *J. Org. Chem.*, 1974, **39**, 3584.
17. D. M. Marion, *Can J. Chem.*, 1953, **31**, 181.
18. J. Rana and D. J. Robins, *J. Chem. Soc., Perkin Trans. 1*, 1986, 1133.
19. W. M. Golebiewski and I. D. Spenser, *J. Am. Chem. Soc.*, 1984, **106**, 7925.
20. Biosynthesis of Pyrrolizidine and Quinolizidine Alkaloids, D. J. Robins in '*The Alkaloids*', 1995, **46**, 1.
21. H. C. Rouse and W. R. Schlesinger, *Virology*, 1967, **33**, 513.
22. G. R. Dubes, K. B. Moyer, B. L. Helliburton and R. K. Van De Bogart, *Acta Virol.*, 1969, **13**, 8.
23. S. M. Chang and S. C. Chung, *Bull. Inst. Chem. Acad. Sinica*, 1968, **15**, 1019.
24. G. Pontecorvo, J. A. Roper, L. M. Hemmona, R. A. McDonald and A. W. J. Bufton, *Advanc. Genet.*, 1953, **5**, 141.

25. B. Lerch and H. Stegeman, *Landw. Forsch.*, 1970, **23**, 181.
26. L. G. Nickell and A. Maretsky, *Physiol. Plant*, 1969, **22**, 117.
27. K. Furuhashi and M. Yatazawa, *Plant Cell Physiol.*, 1970, **11**, 559.
28. J. D. Jones, *J. Nutr.*, 1964, **84**, 313.
29. B. L. O'Dell and F. J. Savage, *J. Nutr.*, 1966, **90**, 364.
30. K. N. Boorman and H. Fisher, *Brit. Poultry Sci.*, 1966, **7**, 39.
31. W. B. Roess and A. G. DeBusk, *J. Gen. Microbiol.*, 1968, **52**, 421.
32. J. D. Jones, S.J. Petersburg and P. C. Burnett, *J. Nutr.*, 1967, **93**, 103.
33. E. Tyihak and B. Szende, *Hung. Pat.*, 1967-1970, **158**, 979.
34. B. Szende, 'The effect of amino acids on tumor growth', *Dissertation*, Budapest, 1973.
35. O. P. Ward, '*Fermentation Biotechnology*', 1989, Open University Press, Milton Keynes.
36. S. Kinoshita, K. Nakayama and S. Kitada, *J. Gen. Appl. Microbiol.*, 1958, **4**, 128.
37. K. Sano and I. Shiro, *J. Gen. Appl. Microbiol.*, 1970, **16**, 373.
38. T. Fufkumara, *Agric. Biol. Chem.*, 1976, **40**, 1687.
39. C. Gilvarg and K. Block, *J. Biol. Chem.*, 1951, **193**, 339.
40. M. Strassman and S. Weinhouse, *J. Am. Chem. Soc.*, 1953, **75**, 1680.
41. M. Strassman and L. N. Ceci, *J. Biol. Chem.*, 1966, **241**, 5401.
42. M. Matsuda and M. Ogur, *J. Biol. Chem.*, 1969, **244**, 5153.
43. A. F. Tucci and L. N. Ceci, *Arch. Biochem. Biophys.*, 1972, **153**, 742.
44. A. K. Sinha and J. K. Bhattacharjee, *Biochem. J.*, 1971, **125**, 743.
45. H. P. Broquist in '*Methods in Enzymology*', (S. P. Colowick and N. O. Kaplan, Eds.) 1971, Vol. 17B, 112-129, Academic Press, New York.
46. H. J. Vogel, J. S. Thompson and G. D. Shockman in '*Organisation and Control in Prokaryotic and Eukaryotic Cells*', (H. P. Charles and B. C. J. G. Knight, Eds.) 1970, 107, Cambridge
47. O. Shaul and G. Galili, *Plant J.*, 1992, **2**, 203.
48. M. W. Gray, *Trends in Genetics*, 1989, **5**, 294.
49. B. Schrupf, A. Schwarzer, J. Kalinowski, A. Puhler, L. Eggeling and H. Sahm, *J. Bacteriol.*, 1991, **173**, 4510.
50. K. Sonntag, L. Eggeling, A. A. De Graaf and H. Sahm, *Eur. J. Biochem.*, 1993, **213**, 1325.
51. R. J. Cox, *Nat. Prod. Rep.*, 1996, in press.
52. F. Richaud, C. Richaud, P. Ratet and J. C. Patte, *J. Bacteriol.*, 1986, **166**, 297.
53. S. Bonnassie, J. Oreglia and A. M. Sicard, *Nucleic Acid Res.*, 1990, **18**, 6421.
54. J. G. Shedlarski and C. Gilvarg, *J. Biol. Chem.*, 1970, **245**, 1362.

55. E. Borthwick, M. Sc. Thesis, University of Glasgow, 1991, 27-43.
56. B. Laber, F.-X. Gomis-Ruth, M.J. Romao and R. Huber, *Biochem. J.*, 1992, **288**, 691.
57. R. M. Cheshire and B. J. Mifflin, *Phytochemistry*, 1975, **14**, 695.
58. M. Mazelis, F. R. Whatley and J. Whatley, *FEBS Lett.*, 1977, **84**, 236.
59. R. M. Wallsgrove and M. Mazelis, *Phytochemistry*, 1981, **20**, 2651.
60. K. Werden, H. W. Heldt and M. Milovancev, *Biochim. Biophys. Acta*, 1975, **396**, 276.
61. R. Kumpaisal, T. Hashimoto and Y. Yamada, *Plant Physiol.*, 1987, **85**, 145.
62. M. Ghislain, V. Frankard and M. Jacobs, *Planta*, 1990, **180**, 480.
63. D. A. Frisch, B. G. Gengenbach, A. M. Tommey, J. M. Sellner, D. A. Somers and D. E. Myers, *Plant Physiol.*, 1991, **96**, 444.
64. C. Dereppe, G. Bold, O. Ghisalba, E. Ebert and H. P. Schar, *Plant Physiol.*, 1992, **98**, 813.
65. E. Borthwick, M. Sc. Thesis, University of Glasgow, 1991, 55-71.
66. E. Borthwick, S. J. Connell, D. W. Tudor, D. J. Robins, A. Shneier, C. Abell and J. R. Coggins, *Biochem. J.*, 1995, **305**, 521.
67. J. M. Ingram and W. A. Wood, *J. Biol. Chem.*, 1966, **241**, 3256.
68. C. Mirwaldt, I. Korndorfer and R. Huber, *J. Mol. Biol.*, 1995, **246**, 227.
69. Y. Yugari and C. Gilvarg, *J. Biol. Chem.*, 1965, **240**, 4710.
70. D. W. Tudor, T. Lewis and D. J. Robins, *Synthesis*, 1993, 1061.
71. R. Kumpaisal, T. Hashimoto and Y. Yamanga, *Agric. Biol. Chem.*, 1989, **53**, 355.
72. W. E. Karsten, *FASEB J.*, 1995, **9**, A1298.
73. A. T. M. Bartlett and P. J. White, *J. Gen. Microbiol.*, 1986, **132**, 3169.
74. A. Selli, F. Crociani, D. DiGioia, F. Fara, G. Grisctig and D. Matteuzzi, *Italian J. Biochem.*, 1994, **43**, 29.
75. I. Negrutui, A. Cattoir-Reynearts, I. Verruggen and M. Jacobs, *Theor. Appl. Genet.*, 1984, **68**, 11.
76. L. Couper, J. E. McKendrick, D. J. Robins and E. J. T. Chrystal, *Bioorg. Med. Chem. Lett.*, 1994, **4**, 2267.
77. W. Farkas and C. Gilvarg, *J. Biol. Chem.*, 1965, **240**, 4717.
78. H. Tamir and C. Gilvarg, *J. Biol. Chem.*, 1974, 3034.
79. K. Kimura and T. Goto, *J. Biochem.*, 1977, **81**, 1367.
80. V. V. S. Tyagi, W. R. Farkas and R. R. Henke, *Plant Physiol.*, 1983, **73**, 687.
81. S. P. Chatterjee, B. K. Singh and C. Gilvarg, *Plant Mol. Biol.*, 1994, **26**, 285.

82. S. G. Reddy, J. C. Sacchettini and J. S. Blanchard, *Biochemistry*, 1995, **34**, 3492.
83. G. Scapin, J. S. Blancard and J. C. Sacchettini, *Biochemistry*, 1995, **34**, 3502.
84. S. A. Simms, W. H. Voige and C. Gilvarg, *J. Biol. Chem.*, 1984, **259**, 2734.
85. C. Richaud, F. Richaud, C. Martin, C. Haziza and J-C. Patte, *J. Biol. Chem.*, 1984, **259**, 14824.
86. L. Couper, D. J. Robins and E. J. T. Chrystal, *Tetrahedron Lett.*, 1992, 2717.
87. P. Shapshak, *Diss. Abstr. Int. B.*, 1970, **31**, 252.
88. K. Kimura and T. Sasakawa, *J. Biochem.*, 1975, **78**, 381.
89. D. A. Berges, W. E. DeWolf, G. L. Dunn, D. J. Newman, S. J. Schmidt, J. J. Taggart and C. Gilvarg, *J. Biol. Chem.*, 1986, **261**, 6160.
90. B. Peterkofsky and C. Gilvarg, *J. Biol. Chem.*, 1961, **236**, 1432.
91. Ref. 74 in R. J. Cox, *Nat. Prod. Rep.*, 1996, in press.
92. J. F. Kirsch, G. Eichele, G. C. Ford, M. G. Vincent, J. N. Jansonius, H. Gerhing and P. Christen, *J. Mol. Biol.*, 1984, **174**, 497.
93. A. J. L. Cooper and O. W. Griffith, *J. Biol. Chem.*, 1979, **254**, 2748.
94. C. H. Scaman, M. M. Palicic, C. McPhalen, M. P. Gore, L. K. P. Lam and J. C. Vederas, *J. Biol. Chem.*, 1991, **266**, 5525.
95. Y. Lin, R. Myhrman, M. L. Dcharg and M. H. Gelb, *J. Biol. Chem.*, 1988, **263**, 1622.
96. S. Weinberger and C. Gilvarg, *J. Bacteriol.*, 1970, **101**, 323.
97. J. Bouvier, C. Richaud, W. Higgins, O. Bogler and P. Stragier, *J. Bacteriol.*, 1992, **174**, 5265.
98. A. Wehrmann, L. Eggeling and H. Sahm, *Microbiology*, 1994, **140**, 3349.
99. A. Boyen, D. Charlier, J. Charlier, V. Sakanyan, I. Mett and N. Glansdorff, *Gene*, 1992, **116**, 1.
100. M. Antia, D. S. Hoare and E. Work, *Biochem. J.*, 1957, **65**, 448.
101. J. S. Wiseman and J. S. Nichols, *J. Biol. Chem.*, 1984, **259**, 8907.
102. P. J. White, B. Lejeune and E. Work, *Biochem. J.*, 1969, **113**, 589.
103. C. Richaud, W. Higgins, D. Mengin-Lecreulx and P. Straiger, *J. Bacteriol.*, 1987, **169**, 1454.
104. C. Richaud and C. Printz, *Nucleic Acids Res.*, 1988, **16**, 10367.
105. W. Higgins, C. Tardif, C. Richaud, M. A. Krivanek and A. Cardin, *Eur. J. Biochem.*, 1989, **186**, 137.
106. W. J. Albery and J. R. Knowles, *Biochemistry*, 1986, **25**, 2572.
107. F. Gerhart, W. Higgins, C. Tardif and J-B Ducep, *J. Med. Chem.*, 1990, **33**, 2157.

108. W. W. Cleland and M.M. Kreevoy, *Science*, 1994, **264**, 1887.
109. B. Mitra, A. T. Kallarakal, J. W. Kozarich, J. A. Gerlt, J. G. Clifton, G. A. Petsko and G. L. Kenyon, *Biochemistry*, 1995, **34**, 2777.
110. R. J. Baumann, E. H. Bohme, J. S. Wiseman, M. Vaal and J. S. Nichols, *Antimicrob. Ag. Chemother.*, 1988, **32**, 1119.
111. M. H. Gelb, Y. Lin, M. A. Pickard, Y. Song and J. C. Vederas, *J. Am. Chem. Soc.*, 1990, **112**, 4932.
112. G. Sundharadas and C. Gilvarg, *J. Biol. Chem.*, 1966, **241**, 3276.
113. S. D. Abbott, P. Lane-Bell, K. P. S. Sidhu and J. C. Vederas, *J. Am. Chem. Soc.*, 1994, **116**, 6513.
114. J. M. Girodeau, C. Agouridas, M. Masson, R. Pineau and F. Le Goffic, *J. Med. Chem.*, 1986, **29**, 1023.
115. L. K. P. Lam, L. D. Arnold, T. H. Kalantar, J. G. Kelland, P. M. Lane-Bell, M. M. Palcic, M. A. Pickard and J. C. Vederas, *J. Biol. Chem.*, 1988, **263**, 11814.
116. H. Misono, H. Togawa, T. Yamamoto and K. Soda, *Biochem. Biophys Res. Commun.*, 1976, **72**, 89.
117. P. J. White, *J. Gen. Microbiol.*, 1983, **129**, 739.
118. H. Minsono, H. Togawa, T. Yamamoto and K. Soda, *J. Bacteriol.*, 1979, **137**, 22.
119. H. Misono, M. Ogasawara and S. Nagasaki, *Agric. Biol. Chem.*, 1986, 2729.
120. L. K. Wenko, R. W. Treick and K. G. Wilson, *Plant Mol. Biol.*, 1985, **4**, 197.
121. H. Minsono, M. Ogasawara and S. Nagasaki, *Agric. Biol. Chem.*, 1986, **50**, 1329.
122. H. Misono and K. Soda, *Agric. Biol. Chem.*, 1980, **44**, 227.
123. H. Misono and K. Soda, *J. Biol. Chem.*, 1980, **255**, 10599.
124. H. Misono and K. Soda, *Agric. Biol. Chem.*, 1980, **44**, 2125.
125. S. Ishino, T. Mizukami, K. Yamaguchi, R. Katsumata and K. Araki, *Nucleic Acids Res.*, 1987, **15**, 3917.
126. S. Ishino, T. Mizukami, K. Yamaguchi, R. Katsumata and K. Araki, *Agric. Biol. Chem.*, 1988, **52**, 2903.
127. H. Minsono, S. Nagasaki and K. Soda, *Agric. Biol. Chem.*, 1981, **45**, 1455.
128. P. J. White and B. Kelly, *Biochem. J.*, 1965, **96**, 75.
129. P. J. White, *Methods in Enzymology*, 1971, **17B**, 140.
130. Y. Asada, K. Tanizawa, Y. Kawabata, H. Minsono and K. Soda, *Agric. Biol. Chem.*, 1981, **45**, 1513.
131. Y. Shimura and H. J. Vogel, *Biochim. Biophys. Acta*, 1966, **118**, 396.

132. M. Mazelis and R. K. Creveling, *J. Food Biochem.*, 1978, **2**, 29.
133. D. L. Dewey and E. Work, *Nature*, 1952, **169**, 533.
134. P. Straiger, O. Danos and J-C. Patte, *J. Mol. Biol.*, 1983, **168**, 321.
135. T. Hammer and R. Bode, *J. Basic Microbiol.*, 1992, **32**, 21.
136. J. Yamamoto, M. Shimizu and K. Yamane, *Agric. Biol. Chem.*, 1991, **55**, 1615.
137. J. Yamamoto, M. Shimizu and K. Yamane, *Nucleic Acids Res.*, 1989, **17**, 10105.
138. D. A. Mills and M. C. Flickinger, *App. Environ. Microbiol.*, 1993, **59**, 2927.
139. A. B. Andersen and E. B. Hansen, *Gene*, 1993, **124**, 105.
140. P. Yeh, A. M. Sicard and A. J. Sinskey, *Mol. Gen. Genet.*, 1988, **212**, 112.
141. C. Martin, B. Cami, P. Yeh, P. Straiger, C. Parsot and J-C. Patte, *Mol. Biol. Evol.*, 1988, **5**, 549.
142. E. Sandmeier, T. I. Hale and P. Christen, *Eur. J. Biochem.*, 1994, **221**, 997.
143. C. Momany, R. Ghosh and M. L. Hackert, *Protein Science*, 1995, **4**, 849.
144. N. V. Grishin, M. A. Philips and E. J. Goldsmith, *Protein Science*, 1995, **4**, 1291.
145. Y. Asada, K. Tanizawa, S. Sawada, T. Suzuki, H. Minsono and K. Soda, *Biochemistry*, 1981, **20**, 6881.
146. J. G. Kelland, L. D. Arnold, M. M. Palcic, M. A. Pickard and J. C. Vederas, *J. Biol. Chem.*, 1986, **261**, 13216.
147. J.-M. Girodeau, C. Agouridas, M. Masson, R. Pineau and F. Le Goffic, *J. Med. Chem.*, 1986, **29**, 1023.
148. D. Schirlin, J. B. Ducep, S. Baltzer, P. Bey, F. Piriou, J. Wagner, J. M. Hornsperger, J. G. Heydt, M. J. Jung, C. Danzin, R. Weiss, J. Fischer, A. Mitschler and A. De Cain. *J. Chem. Soc. Perkin Trans. I*, 1992, 1053.
149. J. E. Baldwin and A. Flinn, *Tetrahedron Lett.*, 1987, **28**, 3605.
150. S. Black and N. Wright, *J. Biol. Chem.*, 1955, **213**, 39.
151. G. C. Barrett, '*Chemistry of the Amino Acids*', 1985, 246-292, Chapman and Hall.
152. J. P. Greenstein and M. Winitz, '*Chemistry of the Amino acids*', 1961, Vols 1-3, 1-52, John Wiley and Sons, New York.
153. M. J. O'Donnell, *Tetrahedron*, 1988, **44**, 439.
154. J. W. P. Asimon and R. P. Seguin, *Tetrahedron*, 1979, **35**, 2797.
155. J. March, '*Advanced Organic Chemistry: Reactions and Structure*', 1985, 3rd Edn., 983, Ref. 110, John Wiley and Sons, New York.
156. U. Schollkopf, *Tetrahedron*, 1983, **39**, 2085.

157. D. S. Tarbell, Y. Yamamoto and B. M. Pope, *Proc. Nat. Acad. Sci., U.S.A.*, 1972, **69**, 730.
158. M. Itoh, D. Hagiwara and T. Kamiya, *Bull. Chem. Soc. Jpn.*, 1977, **50**, 718.
159. B. F. Lundt, N. L. Johansen, A. Volund and J. Markussenl, *Int. J. Pept. Protein Res.*, 1978, **12**, 258.
160. G. W. Anderson and F. M. Callahan, *J. Am. Chem. Soc.*, 1960, **83**, 3359,
161. M. E. Jung and M. A. Lyster, *J. Chem. Soc. Chem. Commun.*, 1978, 315.
162. M. J. O'Donnell and T. M. Eckrich, *Tetrahedron Lett.*, 1978, 4625.
163. P. A. Bartlett and J. F. Barstow, *J. Org. Chem.*, 1982, **47**, 3933.
164. Aldrich catalogue handbook of fine chemicals, 1994-1995, 261.
165. Beilstein., **4(4)**, 257.
166. W. S. Johnson et al., *J. Am. Chem. Soc.*, 1970, **92**, 741.
167. P. Bey and J. Vevert, *Tetrahedron Lett.*, 1978, 1215.
168. J. R. McCarthy, C. L. Barney, M. J. O'Donnell and J. C. Huffman, *J. Chem. Soc. Chem. Commun.*, 1987, 469.
169. J. T. Welch, K. Seper, S. Eswarakrishnan and J. Samartino, *J. Org. Chem.*, 1984, **49**, 4720.
170. T. L. Gilchrist, '*Heterocyclic Chemistry*', 1985, 81-90, Longman Scientific and Technical.
171. R. B. Woodward and R. Hoffmann, *Angew. Chem. Int. Edn. Engl.*, 1969, **8**, 781.
172. I. Fleming, '*Frontier Orbitals and Organic Chemical Reactions*', 1976, Wiley Interscience, London.
173. A. Werner and H. Buss, *Chem. Ber.*, 1894, **27**, 2193.
174. G. Casnati and A. Ricca, *Tetrahedron Lett.*, 1967, 327.
175. K. E. Larsen and K. B. G. Torssell, *Tetrahedron*, 1984, **40**, 2985.
176. R. Huisgen and W. Mack, *Tetrahedron Lett.*, 1961, 587.
177. K. Bast, M. Christl, R. Huisgen and W. Mack, *Chem. Ber.*, 1973, **106**, 3312.
178. A. F. Hegarty and M. Mullane, *J. Chem. Soc. Chem. Commun.*, 1984, 229.
179. J. P. Declercq, G. Germain, M. Van Meerssche, *Acta Chyrstallogr. B.*, 1974, **31**, 229.
180. Y. Wakura, K. Uno, S. Shiraishi and T. Hongu, *Bull. Chem. Soc. Japan*, 1968, **41**, 2954.
181. C. Grundmann and R. Richter, *J. Org. Chem.*, 1967, **32**, 2308.
182. T. Mukaiyama and T. Hoshino, *J. Am. Chem. Soc.*, 1960, **91**, 503.
183. G. S. Skinner, *J. Org. Chem.*, 1923, **46**, 731.
184. A. P. Kozikowski and M. J. Adamczyk, *J. Org. Chem.*, 1983, **48**, 366.

185. P. Touster, *Org. React.*, 1953, **7**, 327.
186. D. H. Williams and I. Fleming, '*Spectroscopic Methods in Organic Chemistry*', 1989, McGraw-Hill, U. K.
187. N. B. Das and K. Torssell, *Tetrahedron*, 1983, **39**, 2247.
188. V. Jager and V. Buss, *Liebigs Ann.*, 1980, 101.
189. L. Panizzi, *Gazz. Chim. Ital.*, 1946, **76**, 44.
190. S. H. Andersen, K.K. Sharma and K. B. G. Torssell, *Tetrahedron*, 1983, **39**, 2241.
191. G. S. King, P. D. Magnus, H. S. Rzepa, *J. Chem. Soc., Perkin Trans. I*, 1972, 437.
192. L. N. Csonka and A. Baich in '*Amino Acids: Biosynthesis and Genetic Regulation*', (K. M. Herrmann and R. L. Somerville, Eds.), 1983, Ch. 3, Addison-Wesley, Reading, Mass.
193. G. Bold, H. Steiner, L. Moech and B. Walliser, *Helv. Chim. Acta*, 1990, **73**, 405.
194. H. Lee and M. J. Miller, *Tetrahedron Lett.*, 1984, 927.
195. A. W. Burgstahler, L. B. Worden and T.B. Lewis, *J. Org. Chem.*, 1963, **28**, 2918.
196. A. O. Bedenbaugh, J. H. Bedenbaugh, W. A. Bergin and J. D. Adkins, *J. Am. Chem. Soc.*, 1970, **92**, 5775.
197. H. C. Brown and Krontnyk, *J. Am. Chem. Soc.*, 1960, **82**, 3866.
198. H. C. Brown and S. Narasihnam, *J. Org. Chem.*, 1982, **47**, 1606.
199. J. G. Moffatt, *Organic Synthesis*, **47**, 24.
200. P. A. Evans, A. B. Holmes and K. Russell, *J. Chem. Soc., Perkin Trans. I*, 1994, 3397.
201. P. L. Beaulieu and P. W. Swiller, *Tetrahedron Lett.*, 1988, 2019.
202. P. L. Beaulieu, J. S. Duceppe and C. Johnson, *J. Org. Chem.*, 1991, **56**, 4196.
203. M. R. Boocock and J. R. Coggins, *FEBS Letters*, 1983, **154**, 127.
204. L. Stryer, '*Biochemistry*', 3rd Edition., W. H. Freeman and Company, New York.
205. D. D. Perrin and L. F. Armarego, '*Purification of laboratory chemicals*', 1992, Pergamon press, UK.
206. E. Taschner, C. Wasielewski, T. Sokolowska and J. F. Biernat, *Liebigs. Ann. Chem.*, 1961, **646**, 127.
207. L. Couper, Ph. D. Thesis, University of Glasgow, 1991, 104-114.
208. L. Couper, Ph. D. Thesis, University of Glasgow, 1991, 41.

