

Associations between Schizotypal traits and Antisocial Behaviours in a sub-Saharan sample

Abstract

Schizophrenic symptoms have often been associated with antisocial behaviours (ASBs). Most studies have focused on violence. The association between schizophrenia and violence is often confounded by socio demographic characteristics of patients. Overemphasis on diagnosis, rather than traits, and the traditional focus on violence may have obscured associations between psychotic features and antisocial behaviour. In this study, an analogue sample (n = 604, females = 54.4%, mean age = 21.46, SD = 5.89) completed self-report measures of schizotypy and antisocial behaviours. The aim was to identify the strength of associations between different schizotypal traits/symptoms (unusual experiences, cognitive disorganisation, impulsivity & introverted anhedonia) and different forms of antisocial behaviour (rule breaking, physical aggression & social aggression). Differential patterns of association between genders were also considered. Traits akin to positive symptoms were more strongly associated with antisocial behaviours. Impulsive non-conformity was associated with rule breaking, physical aggression and social aggression for both males and females whilst unusual experiences traits were associated with physical and social aggression in both males and females but had only a weak (gender-nonspecific) association with rule breaking. Finally, cognitive disorganisation was not associated with any class of ASB for males but was associated with physical and social aggression in females. These specific associations could inform the development of more targeted treatment approaches for specific types of ASBs in males and females.

Introduction

Considerable research attention has been directed to associations between schizophrenia and antisocial behaviours (ASBs). The focus of research has been on violence (see Witt, Van Dorn & Fazel, 2013 and Fazel, Gulati, Linsell, Geddes, & Grann, 2009 for systematic reviews and meta-analyses), whilst some attention has been directed to arson (Anwar, Långström, Grann, & Fazel, 2009) and sexual offending (Alden, Brennan, Hodgins, & Mednick, 2007; Smith & Taylor, 1999). A wide range of ASBs have been neglected and the behaviour of schizophrenia-diagnosed populations is confounded by multiple factors.

People diagnosed with schizophrenia (as a study population) present challenges for interpretation because they typically present with multiple problems. By the time a person is diagnosed with schizophrenia they will often have been exposed to chronic unemployment, homelessness, substance misuse, criminal justice contact, violent behaviour, violent victimisation or other adverse life

experiences (Hodgins & Cote 1993; Moran & Hodgins, 2004; Tengstrom & Hodgins, 2002; Pedersen, Rasmussen, Elsass, & Hougaard, 2010; Varese et al., 2012).

The practice of clinical diagnosis is also a confounding factor because schizophrenia spectrum disorders are best characterised by varied patterns of impairment across a range of symptom-related traits (Torgersen, et al., 2002), collapsing multiple traits into singular diagnoses will inevitably reduce the sensitivity and specificity of any resulting analysis. High levels of comorbidity between antisocial personality, and schizophrenia spectrum disorder complicate confounding further still (Moran & Hodgins, 2004). One way to navigate around these challenges is to consider schizophrenia as an extreme form of variation within a spectrum that has multiple schizotypal trait dimensions and to study continuous variations in relevant trait dimensions within non-diagnosed populations.

Schizotypal traits reflect population-wide liability for schizophrenia (Meehl, 1962; Stefanis, *et al.*, 2002). Schizotypal features are characterised by high levels of suspiciousness, magical thinking, perceptual distortions, constricted affect and odd or eccentric behaviour and speech (Raine, 1991). Additional features identified by DSM-V include odd patterns of beliefs, thinking and speech, along with a lack of close friends and excessive social anxiety (APA, 2013). Elevated levels of schizotypal traits can be a precursor for the later diagnosis of schizophrenia and other schizophrenia spectrum disorders (Dominguez, Wichers, Lieb, Wittchen, & van Os, 2011).

Researchers have employed analogue sampling in order to explore psychological impairment in schizophrenia. Analogue sampling relies on the fact that schizotypal traits may be continuously distributed in the population as a whole and may not be confined to people diagnosed with a psychiatric disorder. Previous research have employed analogous sampling strategy in recruiting healthy volunteers with high levels of schizotypal traits in order to explore primary impairment in schizophrenia without confounding by complex clinical presentation (e.g. Haselgrove & Evans, 2010; van Assche & Giersch, 2012). Hence schizotypy is most frequently construed as a continuous schizophrenia spectrum (Claridge, 1997; Dembińska-Krajewska & Rybakowski, 2014) that spans from the extreme of no schizotypal traits through normal sub-clinical variation, to schizotypal personality disorder, and ending

with schizophrenic presentation with psychotic disorder (Cochrane, Petch, & Pickering, 2010). In keeping with the dimensional trait approach, assessment tools such as the *Oxford-Liverpool Inventory of Feelings and Experiences* (O-LIFE; Mason & Claridge, 2006; Mason, Claridge, & Jackson, 1995), *Oviedo Schizotypy Assessment Questionnaire* (ESQUIZO-Q; Fonseca-Pedrero, Muñiz, Lemos-Giráldez, Paino, & Villazón-García, 2010) and *Schizotypal Personality Questionnaire* (SPQ, Raine, 1991) have been developed to assess psychotic experiences/psychosis proneness in both clinical and non-clinical samples.

Schizophrenia and schizotypal personality have a complex presentation and are composed of multiple symptom clusters and trait dimensions (respectively) yet the literature exploring associations between schizophrenia spectrum disorder and crime has tended to treat schizophrenia as unitary with comparisons typically being made between rates of offending in groups that have a diagnosis versus those that do not. Relatively little attention has been paid to specific associations between symptom clusters and/or personality trait dimensions with antisocial or dissocial behaviours that extend beyond violence. Despite this omission, some studies have linked schizophrenia spectrum disorders with dissocial character traits and behaviours such as deceitfulness, aggression, and rule breaking (Moran & Hodgins, 2004; Robins, 1993). However, studies have not examined which of the features of the schizophrenia spectrum are most strongly associated with different dissocial behaviours.

Antisocial behaviours (ASBs) are heterogeneous in much the same ways as are schizotypal traits dimensions. As noted earlier the literature considering ASBs and schizophrenia has focused on violence and has neglected a wide range of ASBs. ASBs have also been categorised into subtypes (Burt & Donnellan, 2009). Further it is reasonable to suppose that each person's propensity for different subtypes of ASB will be determined (to some extent) by the presence of specific schizotypal personality traits. It is important to note that different forms of ASBs are considered separately as it has been suggested that each may respond to different intervention approaches (Kim, Gilman, & Hawkins, 2015).

Burt and Donnellan (2009) developed the Sub-types of Antisocial Behaviour Questionnaire (STAB) in order to provide a framework for differentiating ASB subtypes. This tool is derived from

DSM-IV (APA) description for Conduct and Antisocial Personality Disorders. The STAB identifies 3 dimensions of physical aggression, social aggression and rule breaking. There is also some evidence that specific relationships can be observed between personality traits and ASB subtypes. For instance, while emotional dysfunction has been linked to more to physical aggression (Burt & Donnellan, 2008; Burt & Larson, 2007), impulsivity has been found to be related more to rule breaking (DeMarte, 2008).

Convergent lines of evidence suggest strong links between schizotypy and ASBs. Dinn et al. (2002) found that positive schizotypy was positively related to impulsivity and that individuals with higher positive schizotypy had higher antisocial personality scores compared to those with low and medium positive schizotypy scores. Ragsdale et al. (2013) found that disturbance in the cognitive-perceptual domain of schizotypy was related to aggressive attitudes and physical aggression, not verbal aggression. Others (e.g. Mason & Cladridge, 2006; Raine, 1991) suggested that positive schizotypal traits are linked to excessive and unstable emotions. Fonseca-Pedrero, Lemos-Giraldez, Paino, and Muniz (2011) examined schizotypal and emotional-behavioural problems in a non-clinical adolescent sample and found that positive schizotypy was related to conduct/hyperactivity problems as well as antisocial personality traits. Despite these convergent lines of evidence we did not find studies exploring specific associations between schizotypal trait dimensions and specific forms of dissocial behaviour. Examining pathway relations between the dimensions of schizotypy and ASBs will improve understanding regarding schizotypal features that trigger specific patterns of ASBs and will thus inform treatments and other interventions. Krakowski, Czobor, and Chou, (1999) and Stompe, Ortwein-Swoboda, and Schanda, (2004) found that positive symptoms of schizophrenia characterized more violent patients. Kawkoski et al, suggested that identifying symptoms associated with different forms of violence has important predictive and differential treatment implication in violent behaviour.

Most research mistakenly treat antisocial and schizophrenia-spectrum characteristics as though they are composite/one-dimensional in nature. As an alternative, we highlight that both schizotypy and ASBs are in fact multi-dimensional. We therefore suppose that schizotypal trait dimensions may have informative specific associations with subtypes of antisocial behaviour. The need for a multi-dimensional consideration in studying schizophrenic traits especially in non-clinical population has been

highlighted elsewhere (Granger, Moran, Buckley & Haselgrove, 2016). In this study we aim to use path analysis to determine how schizotypal trait dimensions are linked to a range of ASBs using the STAB in a sub-Saharan, non-clinical sample of young adults. We hypothesise that the different trait dimensions of schizotypy will be differentially associated with different dimensions of ASB. One additional consideration was the different reported prevalence rates for ASBs in men and women (Alegria et al., 2013; Compton, Conway, Stinson, Colliver, & Grant, 2005). We therefore also examined gender differences in the associations between schizotypal dimensions and ASB dimensions.

Molnar, et al., (2001) report that men and women show different patterns of psychiatric morbidity associated with early adverse experiences. Childhood sexual abuse (CSA) was associated with more diffuse patterns of psychiatric diagnoses in women than in men. For women CSA was associated with diagnoses for a wide range of mood disorders, anxiety disorders and substance disorders, whilst for men CSA was associated with a single anxiety disorder (Posttraumatic stress disorder) and substance disorder diagnoses only. The psychiatric impact of early childhood experiences differs between sexes and it is reasonable to suppose that these differences are mediated by sex-specific differences in personality development. Just as the sexes differ in their response to early adversity it is reasonable also to suppose that antisocial behavioural correlates of schizotypal personality should also be mediated by sex. For this reason, data was also grouped according to gender and path analyses were conducted across the groups for the males and females in the current sample, different patterns of association are anticipated between males and females.

Method

Participants

Participants were 650 undergraduate students from 7 randomly selected faculties in two federal universities in South-Eastern Nigeria. They were aged between 15 and 32 ($M = 21.46$, $SD = 2.89$). Most of the participants were females (54.4%), single (91%) and resided in urban areas (60%). Participants were approached and informed of the study after class sessions and consenting volunteers participated

in the research exercise after completing consent forms. Participants that indicated having had a psychiatric history (n = 46) were identified and removed from the dataset.

Instruments

Subtypes of Antisocial Behaviour

The Subtypes of Antisocial Behaviour (STAB, Burt & Donnellan, 2009) is a 32-item questionnaire developed to assess 3 dimensions of antisocial behaviours of physical aggression, rule breaking and social aggression. The physical aggression subscale measures overt aggressive behaviour that can cause physical harm to others; the social aggression subscale measures behaviour such as gossiping, ostracism which can be expressed either covertly or overtly while the rule breaking subscale taps into antisocial behaviours such as vandalism, theft, truancy and drug abuse (Burt & Donnellan, 2009). The scale has strong psychometric properties shown by the global internal consistency ($\alpha=.82$) and alphas of .85, .86, and .87 for the physical aggression, social aggression, and rule breaking subscales.

Oxford-Liverpool Inventory of Feelings and Experience.

Oxford-Liverpool Inventory of Feelings and Experiences (*short form*) (O-LIFE, Mason, Linney & Claridge, 2005) is advanced as a measure of schizotypy. Originally, the O-LIFE contained 104 items reflecting 4 dimensions, however, the present short form of the O-LIFE contains 54 items which still retain the original dimensions. The dimensions include: *Unusual experiences (UnEx)*, reflecting a tendency to experience unusual cognitive and perceptual sensations or think of things as magically inspired; *cognitive disorganisation (CogDis)*, indicating the display of unconventional patterns of thinking and linking of ideas. *Introvertive anhedonia (IntAn)*, an inclination towards a blunted affect and having minimal pleasure from relating with others or physical pleasure; *Impulsive Nonconformity (ImpNon)* indicates a tendency to not follow social norms and behave in an erratic noncompliant manner especially in reference to the norms of one's society. It usually reflects a lack of self-control. According to the authors, the O-LIFE is originally scored on a dichotomous scale (1-Yes, 0- No), but as we consider schizotypal traits to run on a continuum, responses were structured (with the approval of the original

author Oliver Mason) on a continuous Likert scale (of 1-Never to 5- All the time). Higher scores on the scale suggest more schizotypal traits. The O-LIFE has been and is increasingly deployed across different countries and cultures in studying the schizotypal traits. The current study obtained an alpha coefficients of .87 for all the items on the O-LIFE- short form. Also alphas of .72, .70, .63, and .78 were obtained for the UnEx, CogDis, IntAn and ImpNon subscales respectively.

Procedure

Ethical approval was given by the ethics committee of the Department of Psychology, University of Nigeria. Undergraduates from across 2 tertiary institutions in South Eastern Nigeria were approached in their classrooms and solicited to participate in the study. Information on the consent form stated and assured participants of confidentiality and freedom to withdraw without penalty. They then completed the O-LIFE, and the STAB and a demographic section exploring person characteristics and history of mental illness (including visits to spiritual healers- a practice common place for persons having mental health issues in the region). Access was facilitated most times by course tutors with whom arrangement had been made earlier to gain access to the students at the end of classes. Participants were not offered any form of reinforcements. They were also debriefed at the end of the exercise.

Data analysis

Comparisons were made for gender differences in schizotypy and ASB scores. Bivariate correlation were first computed, examining relationships between the subscales of OLIFE and the STAB (as shown in Table 1) for the sample as whole. This was followed by more detailed and specific path analysis conducted for the sample as a whole and for the 2 sexes separately to determine the extent to which scores on the subscales of the STAB could be predicted from scores on the subscales of the OLIFE. SPSS AMOS version 22 was utilized in the analysis. A conventional alpha ($p < .05$) was set for all analyses.

Results

Mean scores for males and females did not differ on composite scores for the O-LIFE ($t = .91$, $p = .21$) or the STAB ($t = .96$, $p = .09$). However, males on average scored higher on the rule breaking

dimension of the STAB ($t = 4.03, p < .001$) while females scored higher on both the cognitive disorganisation ($t = 2.84, p = .005$) and unusual experiences ($t = 2.10, p = .037$) subscales of the O-LIFE.

Table 1: Descriptive statistics and bivariate correlation between the subscales of OLIFE and STAB

| Variables | M | SD | 1 | 2 | 3 | 4 | 5 | 6 | 7 | 8 | 9 |
|---------------------|--------|------|--------|--------|--------|------|--------|--------|--------|------|---|
| 1 OLIFE (composite) | 110.38 | 7.89 | - | | | | | | | | |
| 2 UnEx | 30.79 | 6.36 | .84*** | - | | | | | | | |
| 3 Cog Dis | 27.15 | 6.06 | .84*** | .73*** | - | | | | | | |
| 4 IntAn | 27.73 | 4.03 | .35*** | -.02 | .08 | - | | | | | |
| 5 ImpCon | 24.66 | 4.52 | .54*** | .22** | .19** | .17* | - | | | | |
| 6 STAB(composite) | 59.25 | 7.82 | .48*** | .48*** | .39*** | .01 | .26*** | - | | | |
| 7 Physical aggr | 21.09 | 5.30 | .40*** | .45*** | .33*** | -.03 | .19** | .79*** | - | | |
| 8 Social aggr | 23.70 | 6.45 | .39*** | .43*** | .33*** | -.02 | .16* | .81*** | .50*** | - | |
| 9 Rule breaking | 14.57 | 4.49 | .27*** | .17* | .20** | .10 | .26*** | .58*** | .23** | .17* | - |

* $p < .05$; ** $p < .01$; *** $p < .001$.

Results of the bivariate correlation showed that the composite score of the O-LIFE was significantly related to the composite score of the STAB ($r = .48, p < .001$) as well as the three dimensions of the STAB rule breaking ($r = .27, p < .001$), physical aggression ($r = .40, p < .001$), and social aggression ($r = .39, p < .001$). Results for the correlation did not reveal results suggestive of multicollinearity between the subscales of the O-LIFE and the STAB (variance inflation factor [VIF] all < 2). This suggests schizotypal traits to be distinct from antisocial characteristics.

We built a regression model predicting composite ASB from the subscales of the OLIFE. Table 2 shows that in the first model, control variables (gender and age) were not significant in predicting ASB. Introducing the dimension of schizotypy, gender turned significant in predicting ASB ($\beta = -.07, p < .05$), suggesting an interaction with the dimensions of schizotypy. Regarding the dimensions of schizotypy, unusual experiences ($\beta = .27, p < .001$), cognitive disorganisation ($\beta = .21, p < .001$) and impulsive nonconformity ($\beta = .28, p < .001$) significantly and positively predicted ASB_{composite}. Introvertive anhedonia did not significantly predict ASB.

Table 2: Regression model predicting ASB composite from control variables and the dimensions of schizotypy.

| Variables | Model 1 | | | Model 2 | | |
|-----------------------------|---------|---------|-------|---------|----------|---------|
| | SE | β | t | SE | β | t |
| Gender (0 males; 1 females) | 1.08 | -.044 | -1.03 | .90 | -.07 | -2.03* |
| Age | .18 | -.06 | -1.30 | .15 | -.00 | -.05 |
| Unusual Exper | | | | .09 | .27 | 6.20*** |
| Cog Dis | | | | .09 | .21 | 4.57*** |
| IntAn | | | | .11 | -.01 | -.30 |
| Imp NonComf | | | | .10 | .28 | 7.90*** |
| R ² | | .01 | | | .34 | |
| ΔR^2 | | .01 | | | .33 | |
| ΔF | | 1.14 | | | 73.67*** | |

* $p < .05$; ** $p < .01$; *** $p < .001$.

Table 3: Path analysis results showing the prediction (standardised betas) of the subscales of the OLIFE from the STAB separately for males and females.

| Predictor | Rule Breaking | | | Physical Aggression | | | Social Aggression | | |
|-------------|---------------|--------|---------|---------------------|--------|---------|-------------------|--------|---------|
| | Total | Males | Females | Total | Males | Females | Total | Males | Females |
| Un Ex | .10* | .11 | .09 | .25*** | .27*** | .24*** | .34*** | .35*** | .24*** |
| CogDis | .07 | .14 | .07 | .14** | .12 | .16** | .33*** | .32 | .23*** |
| IntAn | .04 | .03 | .03 | -.01 | .01 | -.04 | .22 | .22 | -.06 |
| Imp NonConf | .31*** | .25*** | .36*** | .21*** | .35*** | .24*** | .24*** | .24*** | .21*** |

* $p < .05$; ** $p < .01$; *** $p < .001$.

Table 3 shows a summary of the path analysis for prediction of the subscales of the O-LIFE from the behavioural sub-types in the STAB. Following the suspected interaction with gender in Table 2, we analysed differently for both genders. Figures 1 to 3 (**Supplemental online**) shows the pathways of prediction.

Rule breaking

Results show that for the combined sample, rule breaking was significantly predicted by unusual experiences ($\beta = .10$, $p < .05$), but not when both genders were considered separately. Rule breaking was also significantly associated with impulsive non-conformity ($\beta = .31$, $p < .001$); this association was significant for both males and females but it was stronger for females ($\beta = .36$, $p < .001$) than for males ($\beta = .25$, $p < .001$). Cognitive disorganisation ($p = .42$) and introverted anhedonia ($p = .30$) were not significant in predicting rule breaking and this non-significant association was similar for both males and females.

Physical aggression

Physical aggression was significantly associated with unusual experiences ($\beta = .25, p < .001$). The prediction was slightly higher for males ($\beta = .27, p < .001$) than females ($\beta = .24, p < .001$). Cognitive disorganisation also predicted physical aggression ($\beta = .14, p < .01$) in the combined model for males and females. However, in terms of separate gender analysis, cognitive disorganisation significantly predicted physical aggression in females ($\beta = .16, p < .001$) but not in males. Impulsive nonconformity ($\beta = .21, p < .001$) also predicted physical aggression collectively and individually for females ($\beta = .24, p < .001$) and males ($\beta = .18, p < .001$). The power of prediction for females was observed to be more than that for males. Introvertive anhedonia did not significantly predict physical aggression, neither collectively nor in group (males and females).

Social aggression

Social aggression was significantly related to unusual experiences ($\beta = .34, p < .001$), with the association being stronger for males ($\beta = .35, p < .001$) than for females ($\beta = .24, p < .001$). Cognitive disorganisation ($\beta = .33, p < .001$) also predicted social aggression, but was exclusive for females ($\beta = .23, p < .001$) and not males when both genders were compared. Impulsive nonconformity also collectively predicted social aggression both in a combined model ($\beta = .24, p < .001$) and in the distinct models for females ($\beta = .21, p < .001$) and males ($\beta = .24, p < .001$). Introvertive anhedonia did not significantly predict social aggression neither in the collective models for both gender nor for the distinct models. Results consistently showed that introvertive anhedonia was not associated with all the subscales dimensions of ASBs, even across genders.

Discussion

This study explored how specific schizotypal traits dimensions relate to specific types of ASBs in a large sample of young sub-Saharan adults who lived in the community. Sex differences in patterns of association were also examined. Overall schizotypal traits predicted self-reported engagement in antisocial behaviours; furthermore males and females showed different patterns of association between traits and behaviours. Individual schizotypal trait dimensions were considered separately.

Schizotypy impulsive non-conformity trait dimension was most strongly associated with all of the different forms of ASBs, this was the case for both males and females. Impulsive nonconformity was a particularly potent predictor of rule breaking in females and for physical aggression in males. These results are consistent with studies that have found trait impulsivity to be strongly related to ASBs (e.g. DeMarte, 2008, Thibodeau, Cicchetti, Rogosch, 2015; Giannotta & Rydell, 2015). One alternative interpretation may be that the impulsive nonconformity and ASB constructs overlap. Indeed the ImpNon dimension of the OLIFE has been argued to be a measure of psychopathy/criminality than a measure of schizophrenic symptoms (Granger et al., 2016). This may explain its strong prediction of ASBs which often characterize psychopathic or criminal individuals. This alternative interpretation is not supported by the VIF figures and the intercorrelational analysis which did not support the presence of collinearity.

After impulsive nonconformity, unusual experience was the second-most strongly associated trait with ASBs. Unusual experiences predicted rule breaking for the sample as a whole but did not predict rule breaking separately for either of the two sexes. This pattern of results is most likely attributable to increased statistical power haven combined the male and female parts of the sample. The association between unusual experiences and both physical and social aggression was much clearer; unusual experiences predicted both physical and social aggression

in both males and females. These observations are wholly consistent with previous studies that have reported heightened risk for assaults in people reporting psychotic-like experiences (Mojtabai, 2006), as well as positive relationships between positive schizotypal traits and physical aggression (Ragsdale, et al., 2013). However, the current findings are inconsistent with reports that persons high on positive schizotypy do not differ from people who are low in positive schizotypy in interpersonal relationship skills. (Raynal, Goutaudier, Nidetch, & Chabrol, 2016).

Earlier studies have found that positive psychotic symptoms characterized violent patients (Krakowski, et al., 1999; Stompe, et al., 2004). The current study concurs with extant literature but extends knowledge by considering a predictive model beyond violence, elucidating association patterns with subtypes of ASBs which featured different dimensions of aggression. Our study reveals more closely which positive traits in the schizophrenia spectrum is more associated with specific patterns of antisocial behaviours. Additionally, the current study goes further to extend previous observations of sex differences in the sources and forms of antisocial behaviour (e.g. Moffitt, 2001). It is important to note that the association between unusual experiences traits and ASBs was stronger for males than for females. This implies that unusual experiences may trigger physical aggressive behaviours more in men than in females. Cognitive Disorganisation was next in strength in predicting the dimensions of ASB. Though Cognitive disorganisation did not significantly predict rule breaking, it did predict physical and social aggression for combined scores and for females but not males. Hence cognitive disorganisation which depicts features of thought disorders and disorganised aspects of psychosis may prompt the engagement of youths in social and physical aggression, more so, in females.

Lastly, the negative symptoms of schizotypy depicted in introvertive anhedonia did not predict any of the dimensions of ASBs. Introvertive anhedonia was, unlike the other scales, poorly

associated with antisocial behaviours. Introverted Anhedonia traits include features that would be described as negative symptoms in a clinical schizophrenia diagnosis, they are marked by avoidance of social intimacy and a lack of enjoyment from physical and social sources. The current findings are consistent with other studies that have suggested that introverted anhedonia is to be of a distinct form from other schizotypal trait dimensions with distinct behavioural and cognitive correlates (Cella et al. 2013). The absence of volition and emotional arousal seen in anhedonia, may explain the null association with the different dimensions of ASBs. Negative symptoms are often associated with social withdrawal and passiveness and thus such traits may not act out violently (Krakowski et al., 1999).

Implications of the study

To the best of our knowledge, this is the first study that has utilised the OLIFE and STAB in a sub-Saharan sample. Good reliability coefficients concur with studies in other cultures, extending the cross-cultural validity and reliability for both scales. Additionally, our study seems to be the first to consider a dimensional approach to associations between schizotypal characteristics and specific dissocial features. However, as participants were all Nigerians, further studies are needed to ensure a more representative coverage of the sub-Saharan region.

In summary, schizotypal traits are understood to be linked to an array of dissocial traits. This study examined how the different dimensions of schizotypy predicted different forms of antisocial behaviour in young men and women. We found that all dimensions of schizotypy except negative schizotypy had strong links to the different aspects of antisocial behaviour. Interventions targeting prodromal phase of schizophrenia and/or youths who manifest schizotypal traits may be beneficial if they target features of unusual experiences, impulsivity and cognitive disorganisation

for addressing risk for ASBs. Having obtained the above results in a sub-clinical youth sample, prodromal stage interventions that address the management of impulsivity, unusual experiences, and cognitive disorganisation should prove useful in reducing ASBs in young adults. Mueser, Deavers, penn, and Cassisi (2013) reported that intensive community care including home visits, regular assessments, psychoeducation, social skills training and substance use aid are helpful for persons at prodromal stage. Hodgins (2017) recommends that educating patients diagnosed with psychotic disorder on alternative ways to manage interpersonal conflict (by excluding aggression) can be beneficial.

Limitations of the study

The current study is limited in a number of ways. First, some variables known to be contributing to aggressive behaviours such as adverse childhood experiences, substance use, socioeconomic status etc. were not considered in the predictive framework. All analyses were correlational and sampling was cross sectional. Also, measures used in assessing responses were self-report measures which can be prone to impression management, though it was supposed that dissembling would not have contributed to systematic bias.

References

- Alden, A., Brennan, P., Hodgins, S., & Mednick, S. (2007). Psychotic disorders and sex offending in a Danish birth cohort. *Archives of General Psychiatry*, *64*(11), 1251-1258.
- Alegria, A.A., Petry, N.M., Liu, S., Blanco, C., Skodol, A.E., Grant, B., & Hasin, D. (2013). Sex differences in antisocial personality disorder: Results from the national epidemiological survey on alcohol and related conditions. *Personality Disorders*, *4*, 214-212. doi: [10.1037/a0031681](https://doi.org/10.1037/a0031681)
- American Psychiatric Association (2013). *Diagnostic and Statistical Manual Mental Disorders – DSM-V* (5th ed.). Washington, DC: American Psychiatric Association.
- Anwar, S., Långström, N., Grann, M., & Fazel, S. (2009). Is arson the crime most strongly associated with psychosis?—A national case-control study of arson risk in schizophrenia and other psychoses. *Schizophrenia bulletin*, *37*(3), 580-586.

- Burt, S. A. & Donellan, M. B. (2009). Development and validation of the subtypes of antisocial behaviour questionnaire. *Aggressive Behaviour*, 35 (5), 376-398. DOI: 10.1002/ab.20314
- Burt, S. A. & Donnellan, M. B. (2008). Personality correlates of aggressive and non-aggressive antisocial behaviour. *Personality and Individual Differences*, 44 (1), 53-63. DOI: 10.1016/j.paid.2007.07.022
- Burt, S. A. (2009). Rethinking environmental contributions to child and adolescent psychopathology: A meta-analysis of shared environmental influences. *Psychology Bulletin*, 135 (4), 608-637. DOI: 10.1037/a0015702.
- Burt, S.A. & Larson, C.L. (2007). Differential affective responses in those with aggressive versus non-aggressive antisocial behaviors. *Personality and Individual Differences*, 43, 1481–1492.
- Cella, M., Serra, M., Lai, A., Mason, O. J. Sisti, D., Rochi, M. B. L., ... Petretto, D. R. (2013). Schizotypal traits in adolescents: Links to family history of psychosis and psychological distress. *European Psychiatry*, 28, 247-253.
- Claridge, G. (1997). *Schizotypy: Implications for illness and health*. Oxford, NY: Oxford University Press.
- Claridge, G., Clark, K., & Davis, C. (1997). Nightmares, dreams, and Schizotypy. *British Journal of Clinical Psychology*, 36 (3). DOI: 10.1111/j.2044-8260.1997.tb01245.x
- Cochrane, M., Petch, I., Pickering, A. (2010). Do measures of schizotypal personality provide non clinical analogues of schizophrenic symptomatology? *Psychiatry Research* 176, 150–154.
- Compton, W.M., Conway, K.P., Stinson, F.S., Colliver, J.D., & Grant, B.F. (2005). Prevalence, correlates, and comorbidity of DSM-IV antisocial personality syndromes and alcohol and specific drug use disorders in the United States: Results from the national epidemiologic survey on alcohol and related conditions. *Journal of Clinical Psychiatry*, 66, 677–685.
- DeMarte, J. A. (2008). *The heterogeneity of antisocial behaviour: Evidence for distinct dimensions of physical aggression, rule breaking, and social aggression*. East Lansing, MI: Unpublished doctoral dissertation, Michigan State University.
- Dembińska-Krajewska, D. & Rybakowski, J. (2014). The Oxford-Liverpool Inventory of Feelings and Experiences (O-LIFE) schizotypy scale in psychiatry. *Archives of Psychiatry and Psychotherapy*, 2, 15-22.
- Dinn, W.M., Harris, C.L., Aycicegi, A., Greene, P., Andover, M.S. (2002). Positive and negative schizotypy in a student sample: neurocognitive and clinical correlates. *Schizophrenia Research*, 56, 171–185.
- Dominguez, M.G., Wichers, M., Lieb, R., Wittchen, H.-U., van Os, J., 2011. Evidence that onset of clinical psychosis is an outcome of progressively more persistent subclinical psychotic experiences: an 8-year cohort study. *Schizophrenia Bulletin* 37, 84–93.
- Fazel, S., Gulati, G., Linsell, L., Geddes, J. R., & Grann, M. (2009). Schizophrenia and violence: systematic review and meta-analysis. *PLoS medicine*, 6(8), e1000120.

- Fazel, S., Lichtenstein, P., Grann, M., & Langstrom, N. (2010). Bipolar disorder and violent crime: New evidence from population based longitudinal studies and systematic review. *Archives of General Psychiatry*, *67* (9), 931-938.
- Fonseca-Pedrero, E., Lemos-Giraldez, S., Paino, M., & Muniz, J. (2011). Schizotypy, emotional behavioural problems and personality disorder traits in a non-clinical adolescent population. *Psychiatry Research*, *190*, 316-321.
- Fonseca-Pedrero, E., Muñiz, J., Lemos-Giráldez, S., Paino, M., Villazón-García, U., (2010). ESQUIZO-Q: Cuestionario Oviedo para la Evaluación de la Esquizotipia [ESQUIZO-Q: Oviedo Questionnaire for Schizotypy Assessment]. TEA ediciones, Madrid.
- Fonseca-Pedrero, E., Paino, M., Lemos-Giráldez, S., Muñiz, J. (2011b). Schizotypal traits and depressive symptoms in nonclinical adolescents. *Comprehensive Psychiatry*, *52*, 293–300.
- Giannotta, F. & Rydell (2015). The prospective links between hyperactive/impulsive, inattentive, and oppositional-defiant behaviors in childhood and antisocial behavior in adolescence: The moderating influence of gender and the parent–child relationship quality. *Child Psychiatry and Human Development*. doi: 10.1007/s10578-015-0617-0
- Granger, K.T., Moran, P.M., Buckley, M.G., & Haselgrove, M. (2016). Enhanced latent inhibition in high schizotypy individuals. *Personality and Individual Differences*, *91*, 31-39. DOI: 10.1016/j.paid.2015.11.040.
- Haselgrove, M., & Evans, L. H. (2010). Variations in selective and non-selective prediction error with the negative dimension of schizotypy. *Quarterly Journal of Experimental Psychology*, *63*, 1127–1149. <http://doi:10.1080/17470210903229979>
- Hodgins, S & Muller-Isberner, R. (2004). Preventing crime by people with schizophrenic disorders: The role of psychiatric services. *British Journal of Psychiatry*, *185*, 245-250.
- Hodgins, S. & Cote, G. (1993). The criminality of mentally disordered offenders. *Criminal Justice and Behaviour*, *20* (2), 115-129. DOI: 10.1177/0093854893020002001.
- Hodgins, S. (2017). Aggressive behavior among persons with schizophrenia and those who are developing schizophrenia: Attempting to understand the limited evidence on causality. *Schizophrenia Bulletin*, *43*, 1021-1026. doi:10.1093/schbul/sbx079.
- Kim, B. K. E., Gilman, A., & Hawkins, J. D. (2015). School and community-based preventive interventions during adolescence: Preventing delinquency through science-guided collective action. In J. Morizot & L. Kazemian (Eds.), *The development of criminal and antisocial behavior* (pp. 447–460). Cham, Switzerland: Springer International Publishing. http://dx.doi.org/10.1007/978-3-319-08720-7_28
- Krakowski, M., Czobor, P., & Chou, J. C. Y. (1999). Course of violence in patients with schizophrenia: Relationship to clinical symptoms. *Schizophrenia Bulletin*, *25*(3), 505.
- Mason, O., & Claridge, G. (2006). The Oxford-Liverpool Inventory of Feelings and Experiences (O-LIFE): further description and extended norms. *Schizophrenia Research*, *82*(2), 203-211.

- Mason, O., Claridge, G., & Jackson, M. (1995). New scales for the assessment of schizotypy. *Personality and Individual Differences, 18*, 7–13.
- Meehl, P.E. (1962). Schizotaxia, schizotypy, schizophrenia. *American Psychology, 17*, 827 – 838.
- Moffitt, T. E. (2001). *Sex differences in antisocial behaviour: Conduct disorder, delinquency, and violence in the Dunedin Longitudinal Study*. Cambridge university press.
- Mojtabai, R. (2006). Psychotic-like experiences and interpersonal violence in the general population. *Social Psychiatry Epidemiology, 40*, 1 – 8
- Molnar, B.E., Buka, S.L., & Kessler, R.E. (2001). Child sexual abuse and subsequent psychopathology: results from the National Comorbidity Survey. *American Journal of Public Health, 91* (5), 753 – 760.
- Moran, P. & Hodgins, S. (2004). The correlates of comorbid antisocial personality disorder in schizophrenia. *Schizophrenia Bulletin, 30* (4), 791-802.
- Mueser, K. T., Deavers, F., Penn, D. L. & Cassisi, J. E. (2013). Psychosocial treatments for schizophrenia. *Annual Review of Clinical Psychology, 9*, 465–497.
- Nelson, B. & Rawlings, D. (2010). Relating schizotypy and personality to the phenomenology of creativity. *Schizophrenia Bulletin, 36*, 388–399.
- Penney, S.P., Morgan, A., & Simpson, A.I.F. (2016). Assessing illness and non-illness based motivations for violence in persons with major mental illness. *Law and Human Behaviour, 40*, 42-49.
- Ragsdale, K.A. & Bedwell, J.S. (2013). Relationships between dimensional factors of psychopathy and schizotypy. *Frontiers of Psychology: Psychopathology 4*, <http://dx.doi.org/10.3389/fpsyg.2013.00482>
- Ragsdale, K.A., Mitchell, J.C., Cassisi, J.E., & Bedwell, J.S. (2013). Comorbidity of schizotypy and psychopathy: Skin conductance to affective pictures. *Psychiatry Research, 210*, 1000-1007.
- Raine, A. (1991). The SPQ: A scale for the assessment of schizotypal personality based on DSM-III-R criteria. *Schizophrenia Bulletin, 17*, 555–564.
- Raine, A. (2006). Pursuing a second generation of research on crime and schizophrenia. In A. Raine (Ed.), *Crime and schizophrenia: Causes and cures* (pp. 3 - 12). New York: Nova Science Publishers, Inc.
- Raynal, P., Goutaudier, N., Nidetch, V., & Chabrol, H. (2016). Typology of schizotypy in non-clinical young adults: Psychopathological and personality disorder traits correlates. *Psychiatry Research, 246*, 182-187. <http://dx.doi.org/10.1016/j.psychres.2016.09.042>
- Robins, M. (1993). *Experiences of Schizophrenia: An integration of the personal, scientific and therapeutic*. New York: The Guilford Press.
- Sierro, G., Rossier, J., Mason, O., & Mohr, C. (2016). French Validation of the O-LIFE short questionnaire. *European Journal of Psychological Assessment, 32*(3), 195-203. DOI: 10.1027/1015-5759/a000249.

- Smith, A. D., & Taylor, P. J. (1999). Serious sex offending against women by men with schizophrenia. Relationship of illness and psychotic symptoms to offending. *The British Journal of Psychiatry*, *174*(3), 233-237.
- Stefanis, N.C., Hanssen, M., Smirnis, N.K., Avramopoulos, D.A., Evdokimidis, I.K., Stefanis, C.N., Verdoux, H., Van Os, J. (2002). Evidence that three dimensions of psychosis have a distribution in the general population. *Psychol Med*, *32*, 347-358.
- Stompe, T., Ortwein-Swoboda, G., & Schanda, H. (2004). Schizophrenia, delusional symptoms, and violence: The threat/control-override concept reexamined. *Schizophrenia Bulletin*, *30*(1), 31.
- Swanson, J. Estroff, S., Swartz, M., Borum, R., Lachicotte, W., Zimmer, C., & Wagner, R. (1997). Violence and severe mental disorder in clinical and community populations: The effects of psychotic symptoms, *Psychiatry*, *60* (1), 1-22.
- Tengstrom, A. & Hodgins, S. (2002). Criminal behaviour of forensic and general psychiatric patients with schizophrenia: Are they different? *Acta Psychiatr Scand*. *106*, 62-66.
- Thibodeau, E.L., Cicchetti, D., & Rogosch, F. A. (2015). Child maltreatment, impulsivity, and antisocial behavior in African American children: Moderation effects from a cumulative dopaminergic gene index. *Development and Psychopathology*, *27*, 1621 – 1636. doi:10.1017/S095457941500098X
- Torgersen, S., Edvardsen, J., Øien, P. A., Onstad, S., Skre, I., Lygren, S., & Kringlen, E. (2002). Schizotypal personality disorder inside and outside the schizophrenic spectrum. *Schizophrenia Research*, *54*(1), 33-38.
- vanAssche, M., & Giersch, A. (2012). Visual organization processes in schizophrenia. *Schizophrenia Bulletin*, *37* (2), 394-404.
- Varese, F., Smeets, F., Drukker, M., Lieverse, R., Lataster, T., Viechtbauer, W., ... Bentall, R. P. (2012). Childhood adversities increase the risk of psychosis: A meta-analysis of patient-control, prospective- and cross-sectional cohort studies. *Schizophrenia Bulletin*, *38*(4), 661–671. doi:10.1093/schbul/sbs050
- Witt, K., Van Dorn, R., & Fazel, S. (2013). Risk factors for violence in psychosis: systematic review and meta-regression analysis of 110 studies. *PloS one*, *8*(2), e55942.
- Zhang, B., Shen, C., Zhu, Q., Ma, G., & Wang, W. (2016). Processing of facial expressions of emotions in Antisocial, Narcissistic, and Schizotypal personality disorders: An event-related potential study. *Personality and Individual Differences*, *99*, 1-9.

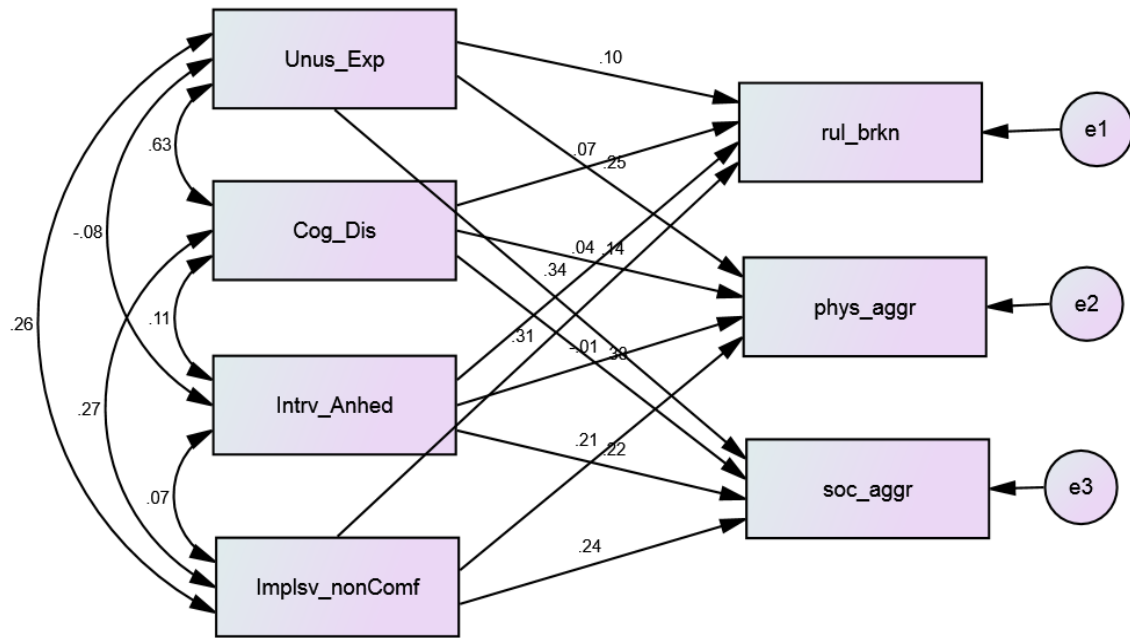

Figure 1 (Supplemental material): Path analysis showing the prediction of the different dimensions of ASB from the facets of schizotypy (male and female combined)

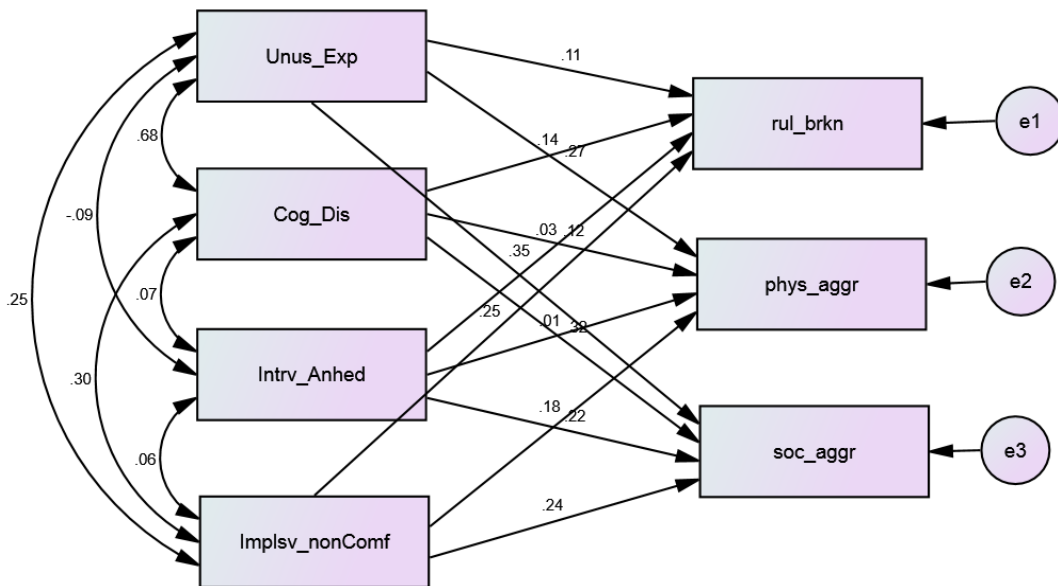

Figure 2 (supplemental material): Path analysis showing prediction patterns for males.

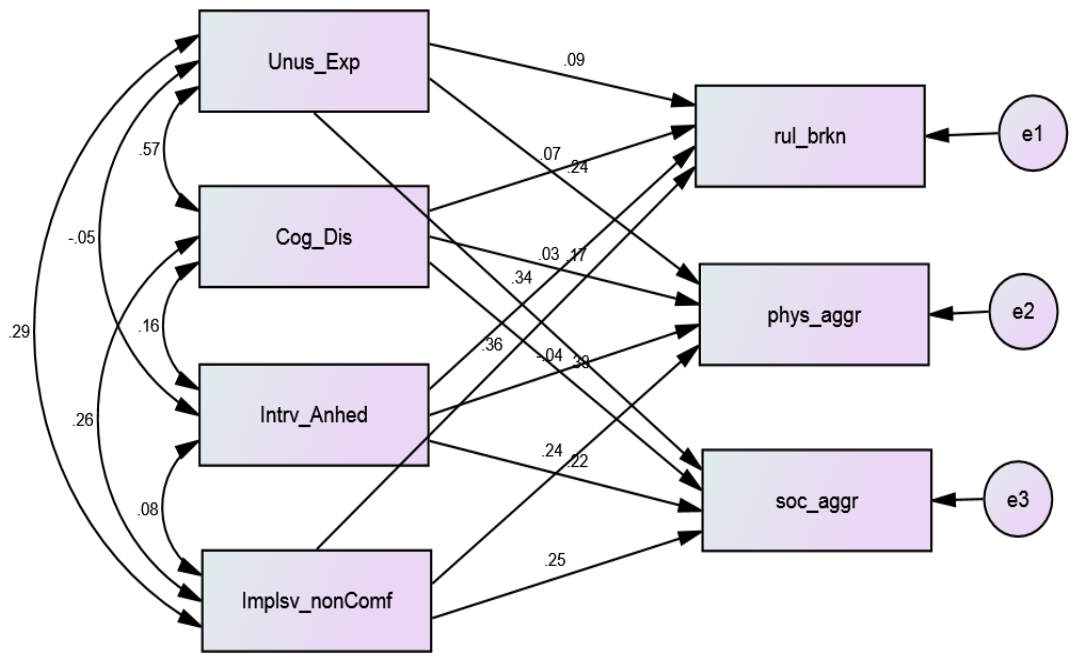

Figure 3 (supplemental material): Path analysis showing prediction patterns for females