

University of Nebraska - Lincoln

DigitalCommons@University of Nebraska - Lincoln

---

Faculty Publications from the Department of  
Electrical and Computer Engineering

Electrical & Computer Engineering, Department  
of

---

2018

## FIBER - OPTIC TEMPERATURE AND FLOW SENSOR SYSTEM AND METHODS

Ming Han

Lincoln, NE, mhan@egr.msu.edu

Guigen Liu

Lincoln, NE

Weilin Hou

Slidell, LA

Follow this and additional works at: <https://digitalcommons.unl.edu/electricalengineeringfacpub>



Part of the [Computer Engineering Commons](#), and the [Electrical and Computer Engineering Commons](#)

---

Han, Ming; Liu, Guigen; and Hou, Weilin, "FIBER - OPTIC TEMPERATURE AND FLOW SENSOR SYSTEM AND METHODS" (2018). *Faculty Publications from the Department of Electrical and Computer Engineering*. 540.

<https://digitalcommons.unl.edu/electricalengineeringfacpub/540>

This Article is brought to you for free and open access by the Electrical & Computer Engineering, Department of at DigitalCommons@University of Nebraska - Lincoln. It has been accepted for inclusion in Faculty Publications from the Department of Electrical and Computer Engineering by an authorized administrator of DigitalCommons@University of Nebraska - Lincoln.



US00995628B1

(12) **United States Patent**  
**Han et al.**

(10) **Patent No.:** **US 9,995,628 B1**  
(45) **Date of Patent:** **Jun. 12, 2018**

(54) **FIBER-OPTIC TEMPERATURE AND FLOW SENSOR SYSTEM AND METHODS**

(71) Applicant: **The Board of Regents of the University of Nebraska**, Lincoln, NE (US)

(72) Inventors: **Ming Han**, Lincoln, NE (US); **Guigen Liu**, Lincoln, NE (US); **Weilin Hou**, Slidell, LA (US)

(73) Assignee: **NUTECH VENTURES**, Lincoln, NE (US)

(\* ) Notice: Subject to any disclaimer, the term of this patent is extended or adjusted under 35 U.S.C. 154(b) by 0 days. days.

(21) Appl. No.: **15/155,773**

(22) Filed: **May 16, 2016**

**Related U.S. Application Data**

(60) Provisional application No. 62/161,730, filed on May 14, 2015.

(51) **Int. Cl.**  
**G01B 9/02** (2006.01)  
**G01J 3/45** (2006.01)  
**G02B 6/293** (2006.01)  
**G02B 6/27** (2006.01)  
**G01J 3/26** (2006.01)  
**G01K 11/32** (2006.01)

(Continued)

(52) **U.S. Cl.**  
CPC ..... **G01J 3/45** (2013.01); **G01F 1/661** (2013.01); **G01J 3/26** (2013.01); **G01K 11/32** (2013.01); **G01P 5/26** (2013.01); **G02B 6/2766** (2013.01); **G02B 6/29359** (2013.01)

(58) **Field of Classification Search**  
CPC ..... G02B 6/29359; G01J 3/26; G01J 3/45; G01F 1/661; G01P 5/26  
See application file for complete search history.

(56) **References Cited**

**U.S. PATENT DOCUMENTS**

6,738,145 B2\* 5/2004 Sherrer ..... G01L 23/16  
250/227.17  
6,925,213 B2\* 8/2005 Boyd ..... G01D 5/268  
385/12

(Continued)

**OTHER PUBLICATIONS**

Lu, Tao et al. "Extrinsic Fabry-Perot cavity optical fiber liquid-level sensor". Applied Optics, vol. 46, No. 18, Jun. 20, 2007, pp. 3682-3687.\*

(Continued)

*Primary Examiner* — Michael A Lyons

(57) **ABSTRACT**

A fiber optic sensor, a process for utilizing a fiber optic sensor, and a process for fabricating a fiber optic sensor are described, where a double-side-polished silicon pillar is attached to an optical fiber tip and forms a Fabry-Pérot cavity. In an implementation, a fiber optic sensor in accordance with an exemplary embodiment includes an optical fiber configured to be coupled to a light source and a spectrometer; and a single silicon layer or multiple silicon layers disposed on an end face of the optical fiber, where each of the silicon layer(s) defines a Fabry-Pérot interferometer, and where the sensor head reflects light from the light source to the spectrometer. In some implementations, the fiber optic sensor may include the light source coupled to the optical fiber; a spectrometer coupled to the optical fiber; and a controller coupled to the high speed spectrometer.

**14 Claims, 7 Drawing Sheets**

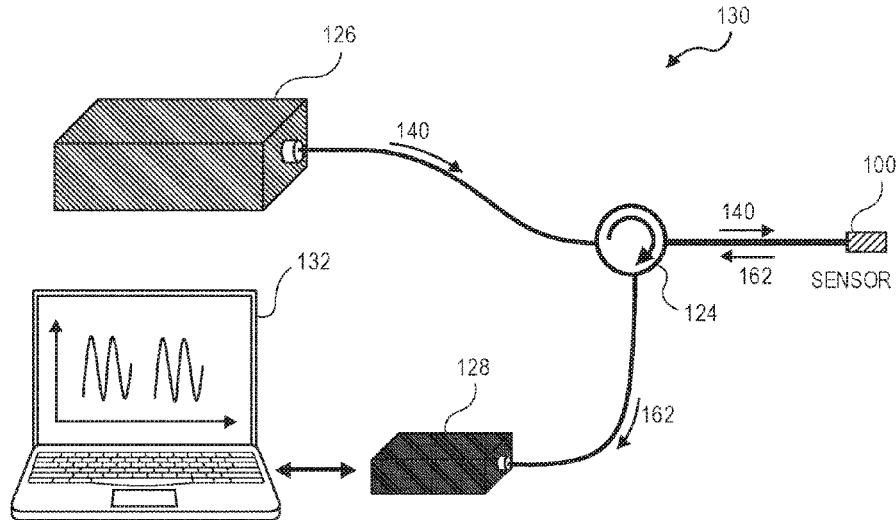

- (51) **Int. Cl.**  
**G01F 1/66** (2006.01)  
**G01P 5/26** (2006.01)

(56) **References Cited**

U.S. PATENT DOCUMENTS

- 2005/0151975 A1\* 7/2005 Melnyk ..... G01B 11/18  
356/480  
2012/0116255 A1\* 5/2012 Wang ..... G01L 7/086  
600/587  
2014/0168659 A1\* 6/2014 Suri ..... G01D 5/268  
356/480  
2014/0208858 A1\* 7/2014 Jiang ..... G01L 11/02  
73/705  
2014/0243688 A1\* 8/2014 Caron ..... G01F 1/6884  
600/478

OTHER PUBLICATIONS

- M. R. Islam, M. M. Ali, M.-H. Lai, K.-S. Lim, and H. Ahmad, "Chronology of Fabry-Perot interferometer fiber-optic sensors and their applications: a review," *Sensors* 14, 7451-7488 (2014).  
B. H. Lee, Y. H. Kim, K. S. Park, J. B. Eom, M. J. Kim, B. S. Rho, and H. Y. Choi, "Interferometric fiber optic sensors," *Sensors* 12, 2467-2486 (2012).  
É. Pinet, "Fabry-Pérot fiber-optic sensors for physical parameters measurement in challenging conditions," *Journal of Sensors* 720980 (2009).  
Y. Zhu, Z. Huang, F. Shen, and A. Wang, "Sapphire-fiber-based white-light interferometric sensor for high-temperature measurements," *Opt. Lett.* 30, 711-713 (2005).  
P. Wang, M. Ding, L. Bo, C. Guan, Y. Semenova, Q. Wu, G. Farrell, and G. Brambilla, "Fiber-tip high-temperature sensor based on multimode interference," *Opt. Lett.* 38, 4617-4620 (2013).  
G. Liu, M. Han, and W. Hou, "High-resolution and fast-response fiber-optic temperature sensor using silicon Fabry-Pérot cavity," *Opt. Express* 23, 7237-7247 (2015).  
W. Hou, S. Woods, E. Jarosz, W. Goode, and A. Weidemann, "Optical turbulence on underwater image degradation in natural environments," *Appl. Opt.* 51, 2678-2686 (2012).  
G. Liu, W. Hou, W. Qiao, and M. Han, "Fast-response fiber-optic anemometer with temperature self-compensation," *Opt. Express* 23, 13562-13570 (2015).  
H. Y. Choi, G. Mudhana, K. S. Park, U.-C. Paek, and B. H. Lee, "Cross-talk free and ultra-compact fiber optic sensor for simultaneous measurement of temperature and refractive index," *Opt. Express* 18, 141-149 (2010).  
H. Y. Choi, K. S. Park, S. J. Park, U.-C. Paek, B. H. Lee, and E. S. Choi, "Miniature fiber-optic high temperature sensor based on a hybrid structured Fabry-Perot interferometer," *Opt. Lett.* 33, 2455-2457 (2008).  
Z. L. Ran, Y. J. Rao, W. J. Liu, X. Liao, and K. S. Chiang, "Laser-micromachined Fabry-Perot optical fiber tip sensor for high-resolution temperature-independent measurement of refractive index," *Opt. Express* 16, 2252-2263 (2007).  
Y. Zhang, X. Chen, Y. Wang, K. L. Cooper, and A. Wang, "Microgap multicavity Fabry-Pérot biosensor," *J. Lightwave Technol.* 25, 1797-1804 (2007).  
M. Born, and E. Wolf, *Principles of Optics* (Cambridge University Press, 1999), Chapter 1.  
H. H. Li, "Refractive index of silicon and germanium and its wavelength and temperature derivatives," *J. Phys. Chem. Ref. Data* 9, 561-658 (1980).  
G. Liu, W. Hou, W. Qiao, and M. Han, "Fiber-optic anemometer based on silicon Fabry-Pérot interferometer," *Proc. of SPIE* 9480, 94800A-(2015).  
Y.J. Rao, "In-fibre Bragg grating sensors," *Meas. Sci. Technol.* 8, 355-375 (1997).  
D. Zhang, J. Wang, Y. Wang, and X Dai, "A fast response temperature sensor based on fibre Bragg grating," *Meas. Sci. Technol.* 25, 075105 (2014).  
S. Bandyopadhyay, J. Canning, M. Stevenson, and K. Cook, "Ultra-high-temperature regenerated gratings in boron-codoped germanosilicate optical fiber using 193 nm," *Opt. Lett.* 33, 1917-1919 (2008).  
S. Khaliq, S. W. James, and R.P. Tatam, "Enhanced sensitivity fibre optic long period grating temperature sensor," *Meas. Sci. Technol.* 13, 792-795 (2002).  
A.M. Hatta, G. Rajan, Y. Semenova, and G. Farrell, "SMS fibre structure for temperature measurement using a simple intensity-based interrogation system," *Electron. Lett.* 45, 1069-1070 (2009).  
Y.B. Zhang, G.R. Pickrell, B. Qi, A. Safaai-Jazi, and A. Wang, "Single-crystal sapphire-based optical high-temperature sensor for harsh environments," *Opt. Eng.* 43, 157-164 (2004).  
G. Coviello, V. Finazzi, J. Villatoro, and V. Pruneri, "Thermally stabilized PCF-based sensor for temperature measurements up to 1000 degrees C.," *Opt. Express* 17, 21551-21559 (2009).  
G. Cocorullo, F. G. D. Corte, M. Iodice, I. Rendina, and P.M. Sarro, "A temperature all-silicon micro-sensor based on the thermo-optic effect," *IEEE T. Electron Dev.* 44, 766-774 (1997).  
M. Ding, P. Wang, and G. Brambilla, "Fast-response high-temperature microfiber coupler tip thermometer," *IEEE Photon. Technol. Lett.* 24, 1209-1211 (2012).  
I. Kajanto, and A.T. Friberg, "A silicon-based fibre optic temperature sensor," *J. Phys. E. Sci. Instrum.* 21, 652-656 (1988).  
L. Schultheis, H. Amstrutz, and M. Kaufmann, "Fiber-optic temperature sensing with ultrathin silicon etalons," *Opt. Lett.* 13, 782-784 (1988).  
J.W. Berthold, S.E. Reed, and R. G. Sarkis, "Reflective fiber optic temperature sensor using silicon thin film," *Opt. Eng.* 30, 524-528 (1991).  
W. Hou, *Ocean Sensing and Monitoring*, Chapter 1 (SPIE Press, 2013).  
J. Komma, C. Schwarz, G. Hofmann, D. Heiner and R. Nawrodt, "Thermo-optic coefficient of silicon at 1550 nm and cryogenic temperatures," *Appl. Phys. Lett.* 101, 041905 (2012).  
F. W. Guo, T. Fink, M. Han, L. Koester, J. Turner, and J.S. Huang, "High-sensitivity, high-frequency extrinsic Fabry-Perot interferometric fiber-tip sensor based on a thin silver diaphragm," *Opt. Lett.* 37, 1505-1507 (2012).  
I.M. White, and X.D. Fan, "On the performance quantification of resonant refractive index sensors," *Opt. Express* 16, 1020-1028 (2008).  
M.N. Ozisik, "Heat Transfer: A Basic Approach", Chapter 8, McGraw-Hill, 1985.  
W. Qu, G.M. Mala, and D. Li, "Heat transfer for water flow in trapezoidal silicon microchannels," *Int. J. Heat Mass Transfer* 43, 3925-3936 (2000).  
M.N. Ozisik, "Heat Transfer: A Basic Approach", Chapter 9, McGraw-Hill, 1985.  
T. Yoshino, K. Kurosawa, K. Itoh, and T. Ose, "Fiber-optic Fabry-Perot Interferometer and its sensor applications," *IEEE Trans. Microwave Theory Tech*, vol. MTT-30, pp. 1612-1621, Oct. 1982.  
W. Hou, *Ocean Sensing and Monitoring*, Chapters 3 and 4 (SPIE Press, 2013).  
W. Hou, *Ocean Sensing and Monitoring*, Chapter 2 (SPIE Press, 2013).  
W. Hou, G. Liu, M. Han, "A novel, high-resolution, high-speed, fiber-optic temperature sensor for oceanographic applications, Current, Waves and Turbulence Measurement (CWTM)," 2015 IEEE/OES Eleventh, 1-4.  
G. Liu, M. Han, W. Hou, S. Matt, W. Goode, "A miniature fiber-optic sensor for high-resolution and high-speed temperature sensing in ocean environment," *Proc. SPIE*, 94590I-6, 2015.  
G. Liu, Q. Sheng, W. Hou, M. Han, "Influence of fiber bending on wavelength demodulation of fiber-optic fabry-perot interferometric sensors," *Optics Express* 24 (23), 26732-26744, 2016.  
G. Liu, Q. Sheng, W. Hou, M. Han, "High-resolution, large dynamic range fiber-optic thermometer with cascaded fabry-perot cavities," *Optics Letters* 41 (21), 5134-5137, 2016.

(56)

**References Cited**

OTHER PUBLICATIONS

G. Liu, Q. Sheng, W. Hou, M. Han, "Optical fiber vector flow sensor based on a silicon fabry-perot interferometer array," *Optics Letters* 41 (20), 4629-4632, 2016.

G. Liu, Q. Sheng, GRL Piassetta, W. Hou, M. Han, "A fiber-optic water flow sensor based on laser-heated silicon fabry-perot cavity," *Proc. SPIE*, 98521B, 2016.

G. Liu, M. Han, "Fiber-optic gas pressure sensing with a laser-heated silicon-based fabry-perot interferometer," *Optics letters* 40 (11), 2461-2464, 2015.

M. Born, and E. Wolf, *Principles of Optics* (Cambridge University Press, 1999), Chapter 7.

\* cited by examiner

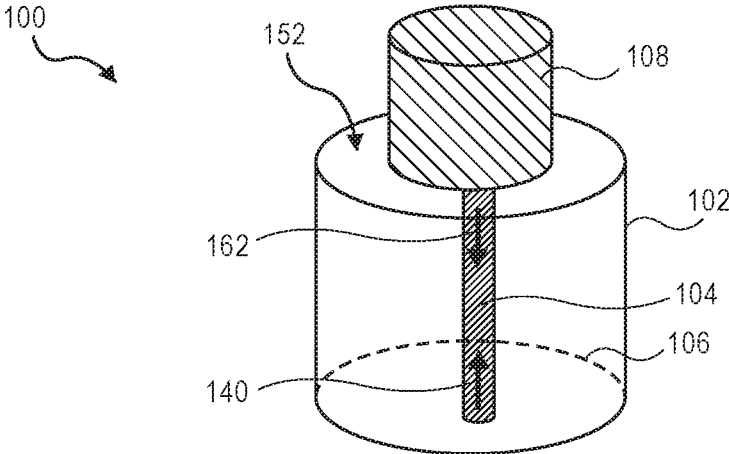

FIG. 1A

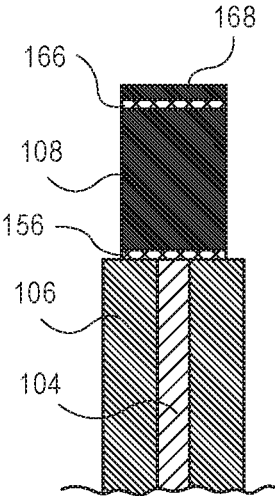

FIG. 1B

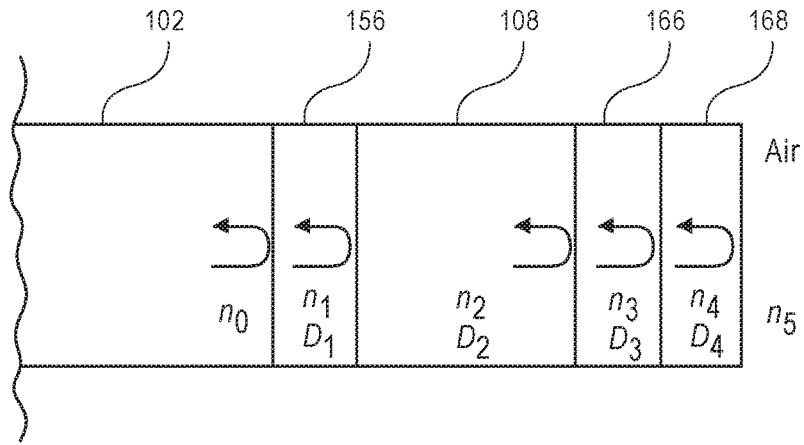

FIG. 1C

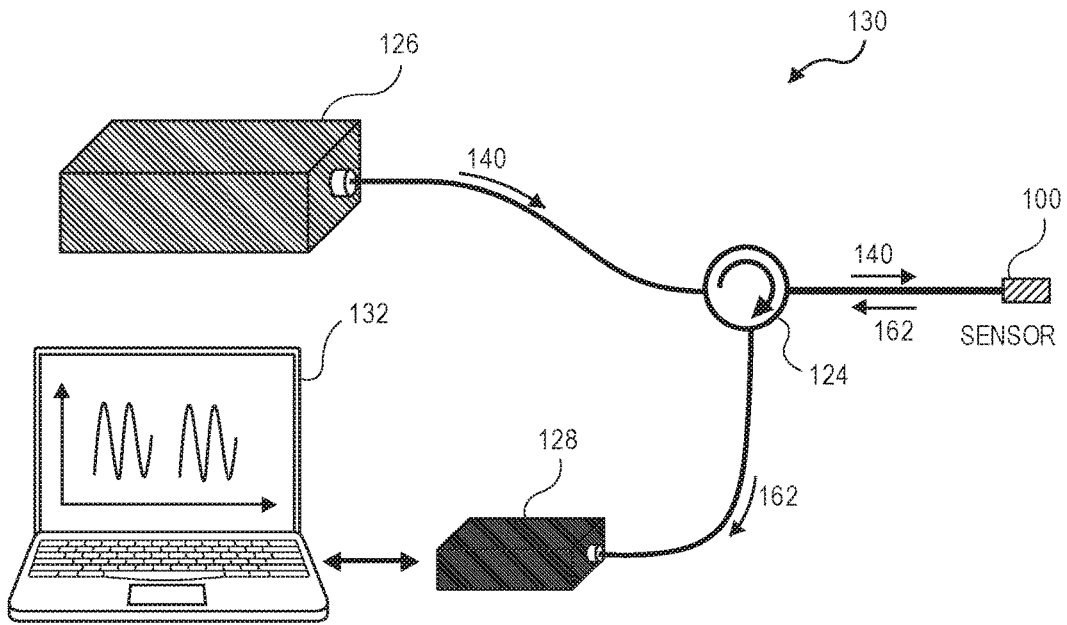

FIG. 1D

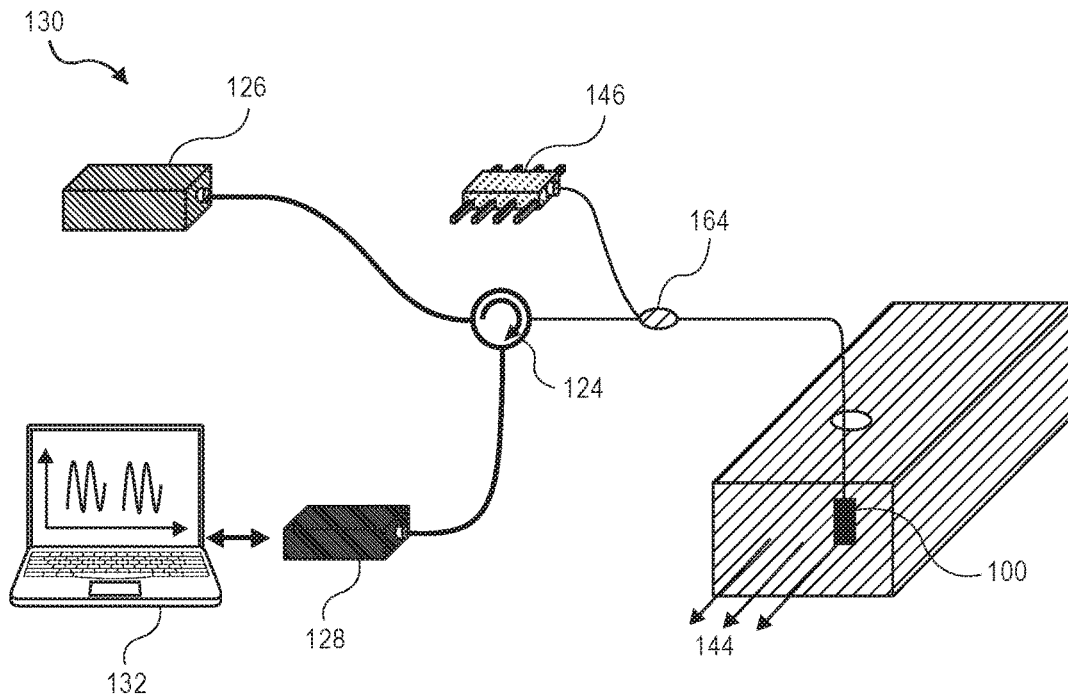

FIG. 1E

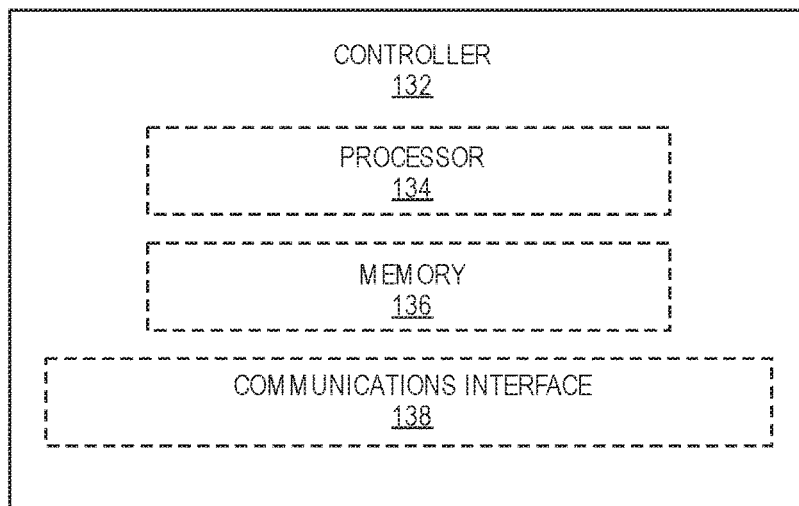

FIG. 1F

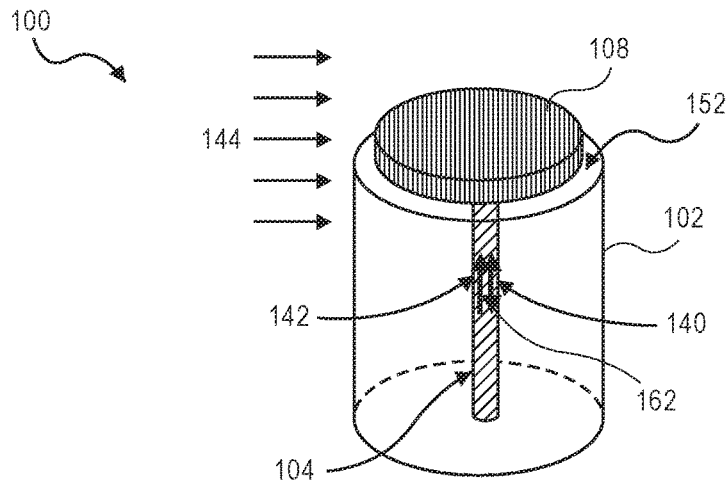

FIG. 1G

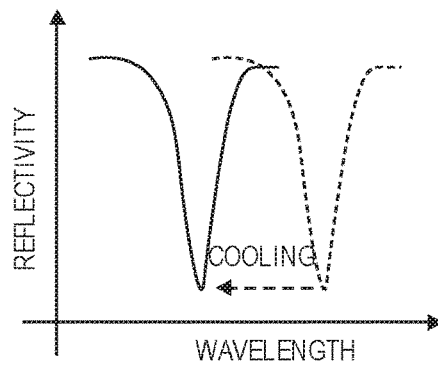

FIG. 1H

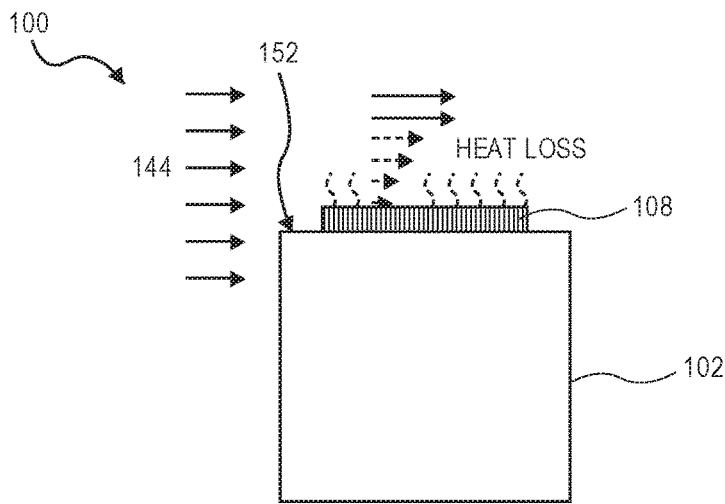

FIG. 1I



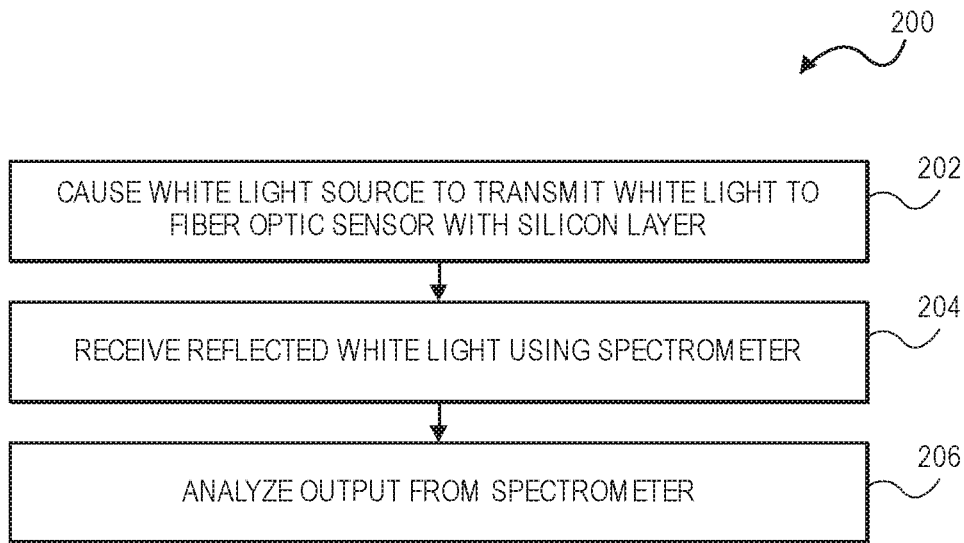

FIG. 2A

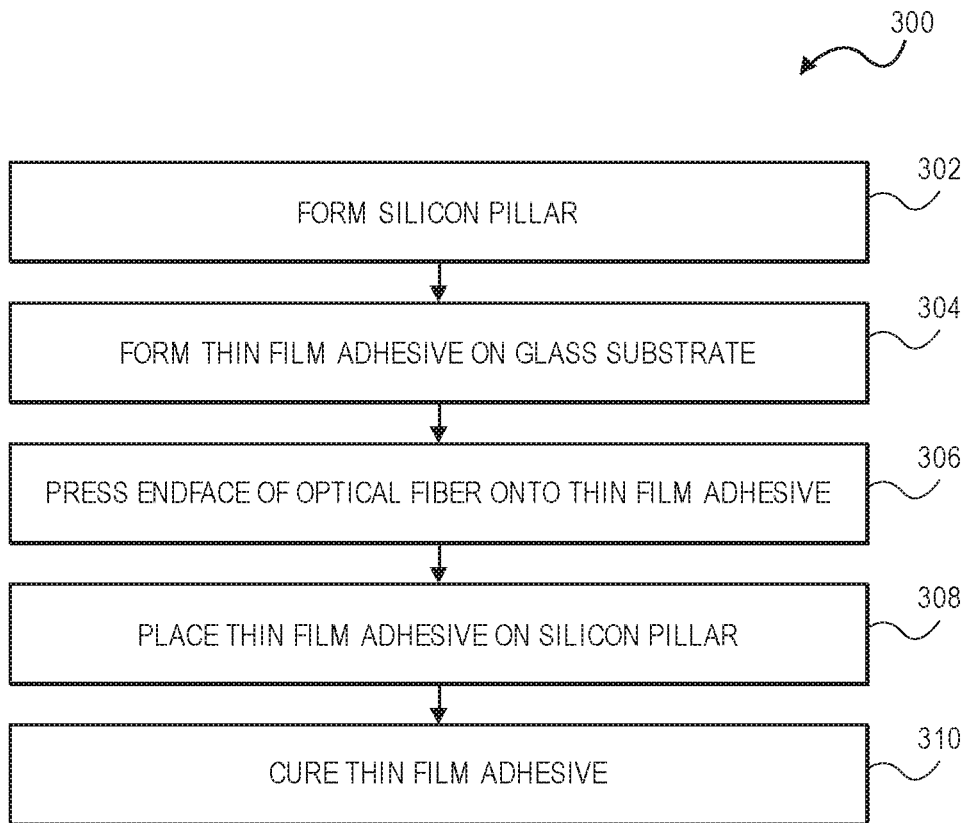

FIG. 2B

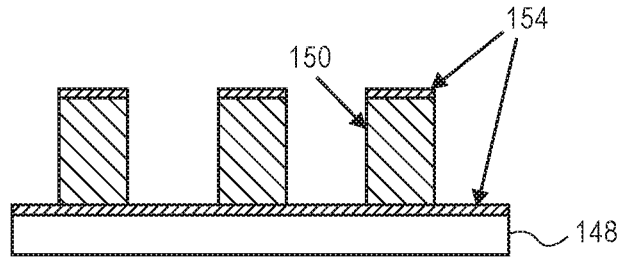

FIG. 3A

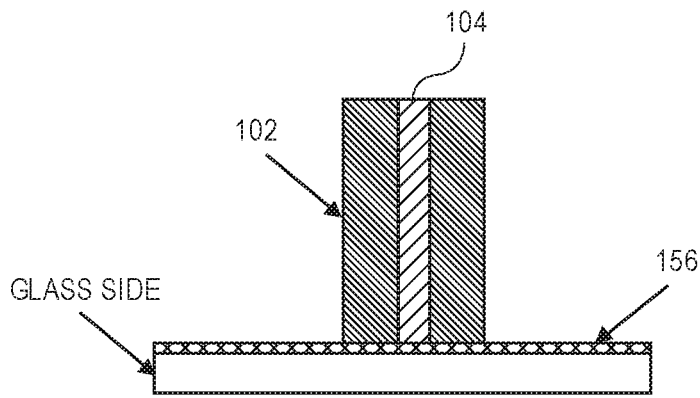

FIG. 3B

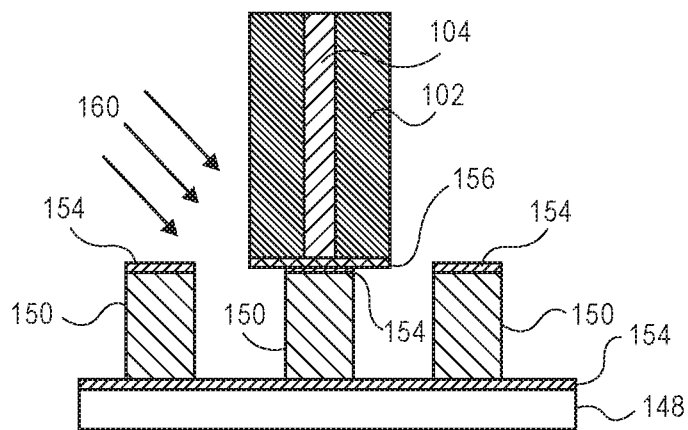

FIG. 3C

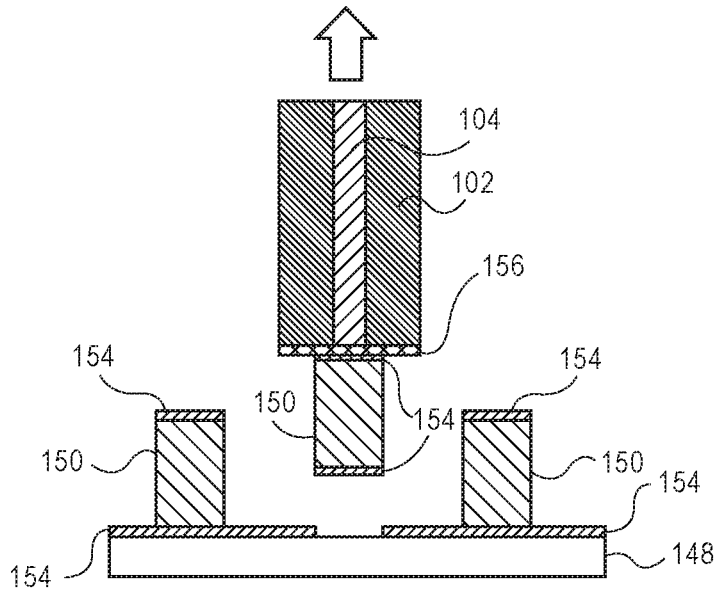

FIG. 3D

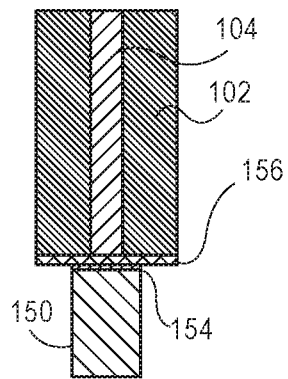

FIG. 3E

## FIBER-OPTIC TEMPERATURE AND FLOW SENSOR SYSTEM AND METHODS

### CROSS-REFERENCE TO RELATED APPLICATIONS

The present application claims the benefit under 35 U.S.C. § 119(e) of U.S. Provisional Application Ser. No. 62/161,730, filed May 14, 2015, and titled "FIBER-OPTIC TEMPERATURE AND FLOW SENSOR SYSTEM AND METHODS." U.S. Provisional Application Ser. No. 62/161,730 is herein incorporated by reference in its entirety.

### FEDERALLY SPONSORED RESEARCH OR DEVELOPMENT

This invention was made with Government support under grant N00173-15-P-0376 awarded by the Naval Research Laboratory. The Government has certain rights in this invention.

### BACKGROUND

An optical fiber can include a flexible, transparent fiber made of extruded glass (silica) or plastic. Light can be transmitted between two ends of the optical fiber, which may be used in fiber-optic communications. A fiber optic sensor uses an optical fiber either as the sensing element (e.g., an intrinsic sensor) or as a means of relaying signals from a remote sensor to electronics that process a signal within the optical fiber (e.g., an extrinsic sensor). Fiber-optic sensors, such as intrinsic sensors, utilize optical fibers to measure temperature, strain, pressure, and/or other characteristics associated with the optical fiber.

### SUMMARY

A fiber optic sensor, a process for utilizing a fiber optic sensor, and a process for fabricating a fiber optic sensor are described, where a double-side-polished silicon pillar is attached to an optical fiber tip and forms a Fabry-Pérot (FP) cavity. In an implementation, a fiber optic sensor in accordance with an exemplary embodiment includes an optical fiber configured to be coupled to a light source and a spectrometer; and a single silicon layer or multiple silicon layers disposed on an end face of the optical fiber, where each of the silicon layer(s) defines a Fabry-Pérot interferometer, and where the sensor head reflects light from the light source to the spectrometer. In some implementations, taking advantage of the dense interference fringes from the silicon FP cavity, average wavelength over multiple peaks or valleys or both is obtained as the signal to further improve the resolution. In some implementations, the fiber optic sensor may include the light source coupled to the optical fiber; a spectrometer coupled to the optical fiber; and a controller coupled to the high speed spectrometer. In some implementations, the fiber optic sensor may include a heating light source coupled to the optical fiber. The fiber optic sensor includes at least one silicon layer and silicon attachment to the fiber for the purpose of temperature and flow sensing. In an implementation, the flow can include various flowing substances (e.g., water, liquid metal, air, other gasses, etc.) that provide cooling effects to the heated sensor head.

In an implementation, a process for utilizing a fiber optic sensor in accordance with an exemplary embodiment includes causing a light source to transmit light through an

optical fiber and a circulator to a fiber optic sensor, where the fiber optic sensor includes a silicon layer disposed on an end face of the fiber optic sensor; receiving reflected light from the fiber optic sensor using a spectrometer, the spectrometer based on a transmission grating and a diode array; and analyzing an output from the spectrometer based on received reflected light. In an implementation, the process for utilizing a fiber optic sensor includes a noise reduction implementation and/or a resolution enhancement implementation based on an improved spectral shift calculation using the average wavelength of multiple peaks and/or valleys.

In an implementation, a process for fabricating a fiber optic sensor in accordance with an exemplary embodiment includes forming at least one silicon pillar on a silicon substrate; forming a thin film adhesive on a glass substrate; pressing an end face of an optical fiber onto the thin film adhesive; releasing the optical fiber with thin film adhesive attached; placing the thin film adhesive on the end face onto the at least one silicon pillar; and curing the thin film adhesive to provide the fiber optic sensor.

This Summary is provided to introduce a selection of concepts in a simplified form that are further described below in the Detailed Description. This Summary is not intended to identify key features or essential features of the claimed subject matter, nor is it intended to be used as an aid in determining the scope of the claimed subject matter.

### DRAWINGS

The detailed description is described with reference to the accompanying figures. The use of the same reference numbers in different instances in the description and the figures may indicate similar or identical items.

FIG. 1A is an isometric view illustrating an embodiment of a fiber optic sensor that includes a silicon layer disposed on an end face of an optical fiber, in accordance with an example implementation of the present disclosure.

FIG. 1B is a partial side elevation cross section view illustrating an embodiment of a fiber optic sensor that includes multiple cascaded silicon layers disposed on an end face of an optical fiber, in accordance with an example implementation of the present disclosure.

FIG. 1C is a partial side elevation cross section view illustrating an embodiment of a fiber optic sensor that includes multiple cascaded silicon layers disposed on an end face of an optical fiber, in accordance with an example implementation of the present disclosure.

FIG. 1D is an environmental view illustrating an embodiment of a fiber optic sensing system that includes a fiber optic sensor with a silicon layer disposed on an end face of an optical fiber, in accordance with an example implementation of the present disclosure.

FIG. 1E is an environmental view illustrating an embodiment of a fiber optic sensing system that includes a fiber optic sensor with a silicon layer disposed on an end face of an optical fiber, in accordance with an example implementation of the present disclosure.

FIG. 1F is an environmental view illustrating an embodiment of a controller used in a fiber optic sensing system, in accordance with an example implementation of the present disclosure.

FIG. 1G is an isometric view illustrating an embodiment of a fiber optic sensor that includes a silicon layer disposed on an end face of an optical fiber, in accordance with an example implementation of the present disclosure.

FIG. 1H is a graphical depiction illustrating a wavelength shift that represents a temperature change using a fiber optic

sensor that includes a silicon layer disposed on an end face of an optical fiber, in accordance with an example implementation of the present disclosure.

FIG. 1I is a side elevation cross sectional view illustrating an embodiment of a fiber optic sensor that includes a silicon layer disposed on an end face of an optical fiber, in accordance with an example implementation of the present disclosure.

FIG. 2A is a flow diagram illustrating an example process for using a fiber optic sensor that includes a silicon layer disposed on an end face of an optical fiber, such as the fiber optic sensor illustrated in FIGS. 1A through 1G.

FIG. 2B is a flow diagram illustrating an example process for fabricating a fiber optic sensor that includes a silicon layer disposed on an end face of an optical fiber, such as the fiber optic sensor illustrated in FIGS. 1A through 1G.

FIG. 3A is a diagrammatic partial cross-sectional side elevation view illustrating the fabrication of a fiber optic sensor that includes a silicon layer disposed on an end face of an optical fiber, such as the fiber optic sensor illustrated in FIGS. 1A through 1G, in accordance with the process shown in FIG. 2B.

FIG. 3B is a diagrammatic partial cross-sectional side elevation view illustrating the fabrication of a fiber optic sensor that includes a silicon layer disposed on an end face of an optical fiber, such as the fiber optic sensor illustrated in FIGS. 1A through 1G, in accordance with the process shown in FIG. 2B.

FIG. 3C is a diagrammatic partial cross-sectional side elevation view illustrating the fabrication of a fiber optic sensor that includes a silicon layer disposed on an end face of an optical fiber, such as the fiber optic sensor illustrated in FIGS. 1A through 1G, in accordance with the process shown in FIG. 2B.

FIG. 3D is a diagrammatic partial cross-sectional side elevation view illustrating the fabrication of a fiber optic sensor that includes a silicon layer disposed on an end face of an optical fiber, such as the fiber optic sensor illustrated in FIGS. 1A through 1G, in accordance with the process shown in FIG. 2B.

FIG. 3E is a diagrammatic partial cross-sectional side elevation view illustrating the fabrication of a fiber optic sensor that includes a silicon layer disposed on an end face of an optical fiber, such as the fiber optic sensor illustrated in FIGS. 1A through 1G, in accordance with the process shown in FIG. 2B.

### DETAILED DESCRIPTION

Measurement of speed of gas or liquid flow is of great practical importance in a variety of industries, such as food inspection, pharmacy, oil/gas exploration, environmental, high-voltage power systems, chemical plants, and oceanography research. Owing to their many unique advantages, such as small size, light weight, immunity to electromagnetic interference, remote sensing capability, harsh environment tolerance, and capability for distributed or quasi-distributed measurement fiber-optic sensors, such as temperature sensors, flowmeters, or anemometers, have proven to be attractive alternatives to their traditional mechanical or electromagnetic counterparts.

In addition to sensitivity and temperature range, two important sensor parameters include temperature resolution and speed (or response time). Temperature resolution, defined as the minimum detectable temperature changes, is determined by both the sensor sensitivity (defined as the sensor output from a given temperature change) and the

noise of the sensor system, while the response time is mostly limited by the time constant of the heat transfer process between the sensing element and the surrounding environment. The sensing element of many fiber-optic temperature sensors is part of the fiber itself, which is made of fused silica. The temperature resolution and the speed are limited by the relatively low thermo-optic coefficient (TOC) and thermal diffusivity of the glass material that lead, respectively, to a reduced sensor sensitivity and increased time for the temperature of the sensing element to reach equilibrium with the surrounding environment. For example, it is well-known that a fiber Bragg grating (FBG), whose reflection spectrum features a single reflection peak, exhibit a temperature sensitivity of about  $10 \text{ pm}/^\circ \text{C}$ . A fiber modal interferometer based on a single mode-multimode-single mode fiber structure has been reported to have a temperature resolution of  $0.2^\circ \text{C}$ . Many all-silica-fiber-based temperature sensors possess relatively low sensitivity and relatively low temperature resolution. As to the response time, a package of a FBG with a copper tube encapsulation can greatly reduce the response time of the sensor from several seconds to 48.6 milliseconds (ms) in water. A response time of 16 ms in air has been demonstrated for a microfiber coupler tip temperature sensor.

Compared to fused silica, crystalline silicon is a much more desirable sensor material for high-resolution and high-speed temperature sensing. Silicon is highly transparent over the infrared wavelength and has a TOC approximately 10 times larger than that of fused silica used for the sensing element for most fiber-optic sensors, resulting in potentially much higher temperature sensitivity. In addition, a silicon-based temperature sensor also has high speed because of the large thermal diffusivity of silicon, which is comparable to many metals (e.g., aluminum and gold) and is more than 60 times larger than fused silica. However, the use of silicon as a temperature sensing element has not been utilized on a large scale for high-resolution and high-speed temperature sensing. The dependence of the absorption of a silicon film on temperature for temperature sensing and the sensor has shown a relatively low temperature resolution of  $\pm 0.12^\circ \text{C}$ . and a long response time on the order of 1 second (s). A simpler structure with a thin silicon film (thickness  $< 1 \mu\text{m}$ ) deposited directly on the fiber end through electron-beam evaporation has shown a temperature resolution of only  $3^\circ \text{C}$ . In this case, radio-frequency sputtering was applied to simplify the deposition process, and the resolution was mainly limited by the small thickness of the silicon film that led to broad spectral fringes. Instead of silicon film, a silicon micro-waveguide patterned on a micro-electro-mechanical system (MEMS) was developed as temperature sensor, and due to the increased length of the Si sensing element, the temperature resolution was improved to  $0.064^\circ \text{C}$ . However, it is a challenge to integrate the fiber and the MEMS into a single sensor device, and the large size of previous sensing elements also limit their temperature measurement speed.

Accordingly, a fiber optic sensor, a process for utilizing a fiber optic sensor, and a process for fabricating a fiber optic sensor are described, where a double-side-polished silicon pillar is attached to an optical fiber tip and forms a Fabry-Pérot (FP) cavity and a sensor head. In an implementation, a fiber optic sensor in accordance with an exemplary embodiment includes an optical fiber configured to be coupled to a light source and a spectrometer; and a single silicon layer or multiple silicon layers disposed on an end face of the optical fiber, where each of the silicon layer(s) defines a Fabry-Pérot interferometer, and where the sensor head reflects light from the light source to the spectrometer.

In some implementations, the fiber optic sensor may include the light source coupled to the optical fiber; a spectrometer coupled to the optical fiber; and a controller coupled to the high speed spectrometer. In some implementations, the fiber optic sensor may include a heating light source coupled to the optical fiber.

In an implementation, a process for utilizing a fiber optic sensor in accordance with an exemplary embodiment includes causing a light source to transmit light through an optical fiber and a circulator to a fiber optic sensor, where the fiber optic sensor includes a silicon layer disposed on an end face of the fiber optic sensor; receiving reflected light from the fiber optic sensor using a spectrometer, the spectrometer based on a transmission grating and a diode array; and analyzing an output from the spectrometer based on received reflected light.

In an implementation, a process for fabricating a fiber optic sensor in accordance with an exemplary embodiment includes forming at least one silicon pillar on a silicon substrate; forming a thin film adhesive on a glass substrate; pressing an end face of an optical fiber onto the thin film adhesive; releasing the optical fiber with thin film adhesive attached; placing the thin film adhesive on the end face onto the at least one silicon pillar; and curing the thin film adhesive to provide the fiber optic sensor.

The high-speed fiber optic sensor and processes disclosed herein increase the temperature response and/or decrease the response time of the sensor. The diameter of the pillar (e.g., 80  $\mu\text{m}$  or 100  $\mu\text{m}$ , smaller than the optical fiber diameter) leads to a fast temperature response. The length of the pillar (e.g.,  $\sim 200$   $\mu\text{m}$ ) together with the large refractive index (RI) of the silicon material result in dense fringes in the reflection spectrum of the FP cavity. Using this unique spectral characteristic of the fiber optic sensor, the noise is significantly reduced and the measurement resolution is improved. The sensor described herein has, in one exemplary implementation, shown a high temperature resolution of  $6 \times 10^{-4}$  C. and a short response time of 0.51 ms. This fiber optic sensor with a high-resolution and fast-response is especially effective in the precise and real-time characterization of temperature structure in highly dynamic optical turbulence.

#### Example Implementations

FIGS. 1A through 1I illustrate a fiber optic sensor 100 and fiber optic sensing system 130 in accordance with an example implementation of the present disclosure. The fiber optic sensor 100 can include an optical fiber 102 configured to be coupled to a light source 126 and a high speed spectrometer 128. The fiber optic sensor 100 and fiber optic sensing system 130 may be utilized as a temperature sensor in determining temperature in gas and liquid.

In implementations, the optical fiber 102 can include a flexible, transparent fiber core 104 made of extruded glass (e.g., silica) or a polymer. The optical fiber 102 can be configured to transmit light between the two ends of the optical fiber 102. In some instances, the optical fiber 102 may be immune to electromagnetic interference.

The optical fiber 102 can include the core 104 and/or a cladding 106. The core 104 may include a fiber of glass and/or plastic that extends along the length of the optical fiber 102. The core 104 may be surrounded by a cladding 106, which may include a material with a lower index of refraction than the core 104. In embodiments, the cladding 106 may include a cladding of a different glass and/or plastic, a buffer layer, and/or a jacket.

As illustrated in FIG. 1A, the fiber optic sensor 100 can include a silicon layer 108 disposed on an end face 152 of the optical fiber 102 (e.g., a cleaved portion of the optical

fiber 102), which forms a sensor head. In implementations, the silicon layer 108 can include a silicon pillar and/or a silicon-based film. In a specific embodiment, the silicon layer 108 includes a double-sided polished silicon pillar. In another specific embodiment, the silicon layer 108 can include a piece of a silicon wafer bonded to the end face 152. The silicon layer 108 may include various diameters and/or lengths. For example, the silicon layer 108 can include a silicon pillar with a diameter between about 80  $\mu\text{m}$  to 100  $\mu\text{m}$  with a length of about 200  $\mu\text{m}$ . In another example, the silicon layer 108 may include a piece of silicon that is approximately 10  $\mu\text{m}$  thick. In yet another example, the silicon layer 108 can include a piece of silicon that is approximately 200  $\mu\text{m}$  thick. It is contemplated that the silicon layer 108 may include other diameters and/or lengths. The silicon layer 108 diameter is generally less than the diameter of the optical fiber 102, which leads to a fast temperature response. The silicon in the silicon layer 108 is highly transparent over the infrared wavelength and has a TOC approximately 10 times larger than that of the silica used in the optical fiber 102 for most fiber-optic sensors, resulting in potentially much higher temperature sensitivity. In addition, the fiber optic sensor 100 also has high speed because of the large thermal diffusivity of silicon, which is comparable to many metals (e.g., aluminum and gold) and more than 60 times larger than fused silica. In other implementations, the silicon layer 108 may be replaced with other materials that have large thermal diffusivity and high thermo-optic and thermal expansion coefficients. Further, it is contemplated that the silicon layer 108 can include other configurations, such as a cuboid configuration.

As illustrated in FIGS. 1B and 1C, the fiber optic sensor 100 may include cascaded Fabry-Pérot cavities. In these implementations, the fiber optic sensor 100 can include an adhesive 156 disposed on an end face 152 of the optical fiber 102, a silicon layer 108 disposed on the adhesive 156, a second adhesive 166 disposed on the silicon layer 108, and a second silicon layer 168 disposed on the second adhesive 166. The silicon layer 108 and the second silicon layer 168 include the same material so that each has the same responsiveness to temperature. In such a way, the large free spectrum range (FSR) of the envelope originating from the second silicon layer 168 (the second Fabry-Pérot interferometer) provides large dynamic range, while the recognized dense fringes with small FSR stemming from the silicon layer 108 (the first Fabry-Pérot interferometer) offers high resolution due to the narrow fringes. The adhesive 156 and/or the second adhesive 166 can include materials suitable to bond the optical fiber 102, the silicon layer 108, and/or the second silicon layer 168 (e.g., a UV glue, etc.). Additionally, the adhesive 156 and/or the second adhesive 166 can be the same or similar diameter as the silicon layer 108 and/or second silicon layer 168, while the thickness of the adhesive 156 and/or the second adhesive 166 can be only a few microns (e.g.,  $<1$   $\mu\text{m}$ , 2  $\mu\text{m}$ , 3  $\mu\text{m}$ , etc.). Because the adhesive 156 and/or the second adhesive 166 are very thin compared to the silicon layer 108 and the second silicon layer 168, they show negligible influence on the reflection spectrum of reflected light 162. In specific embodiments, the silicon layer 108 and the second silicon layer 168 can be the same or similar diameters but have different lengths (e.g., the silicon layer 108 is 200  $\mu\text{m}$  in length and the second silicon layer 168 is 10  $\mu\text{m}$  in length). It is contemplated that the silicon layer 108 and/or the second silicon layer 168 can include a variety of lengths and/or diameters. In FIG. 1C,  $n_i$  and  $D_i$  represent the refractive index and separation of the  $i^{\text{th}}$  layer, respectively. These implementations provide an opti-

cal fiber thermometer based on double cascaded Fabry-Pérot interferometers both made from the same material of silicon but with vastly different cavity lengths to achieve both large dynamic and high resolution.

In implementations, the fiber optic sensor **100** defines and includes a Fabry-Pérot (FP) cavity. A Fabry-Pérot cavity (or Fabry-Pérot interferometer) can include a cavity formed by the optical fiber **102** and the silicon layer **108** disposed on the end face **152** of the optical fiber **102**. Due to the thermo-optic effect, temperature variations change the optical thickness of the FP cavity and consequently cause spectral shifts in its reflection spectrum.

As illustrated in FIG. 1D, the fiber optic sensing system **130** can include the fiber optic sensor **100**, a light source **126**, a circulator **124**, a spectrometer **128**, and a controller **132**. In some implementations, the fiber optic sensing system **130** may include a heating light source **146**.

In implementations, the light source **126** (e.g., a broad band source) transmits light to the circulator **124** and the fiber optic sensor **100**. In one specific embodiment, light source **126** includes a wavelength swept laser, such as a high-speed, narrow-linewidth, and wavelength-swept laser. In another specific embodiment, light source **126** includes a laser diode. In yet another specific embodiment, light source **126** includes a white light source (e.g., 1550 nm). It is contemplated that the light source **126** can include other types of light sources. In implementations, the light source **126** is optically coupled to the optical fiber **102**, which is optically coupled to a circulator **124**. Additionally, the light source **126** can be coupled to and controlled using controller **132**.

As illustrated in FIG. 1E, the fiber optic sensing system **130** may include a heating light source **146** configured to provide heating light **142**. In these embodiments, the heating light source **146** can include a light source, such as a red laser diode, that is optically coupled to the optical fiber **102** using a coupler **164**. In one specific instance, the heating light source **146** can include a 635 nm diode laser. The heating light source **146** may include other light sources that provide light, which can be absorbed by the fiber optic sensor **100** and/or the silicon layer **108**. Additionally, the heating light source **146** can be controlled using controller **132**.

A circulator **124** can include a fiber-optic component used to separate optical signals in optical fiber **102**. In implementations, circulator **122** can direct transmitted light **140** from light source **126** (and/or heating light **142** from heating light source **146**) to fiber optic sensor **100** while directing reflected light **162** from the fiber optic sensor **100** to spectrometer **128**.

The fiber optic sensing system **130** can include a spectrometer **128** coupled to the optical fiber **102** and a controller **132**. In implementations, a spectrometer **128** can include a light sensor, such as a photodetector, configured to detect reflected light **162** and the associated spectra from the optical fiber **102** and fiber optic sensor **100**. In a specific embodiment, the spectrometer **128** may include a high-speed photodetector (e.g., the high speed spectrometer from Ibsen Photonics, I-MON 256 USB, Denmark). Additionally, the spectrometer **128** can be coupled to and controlled using controller **132**.

As reflected light **162** is received and/or detected by spectrometer **128**, a shift in wavelength is detected when temperature changes at the silicon layer **108**. The wavelength of the  $N^{th}$  fringe peak,  $\lambda_N$ , of the reflection spectrum is given as

$$\left(N + \frac{1}{2}\right)\lambda_N = 2nL \quad \text{Eq. 1}$$

where  $n$  and  $L$  are, respectively, the RI and cavity length of the FP cavity. Both  $n$  and  $L$  are dependent on temperature due to the thermo-optic effect and the thermal expansion of the silicon material. Therefore, temperature change can be measured by monitoring  $\lambda_N$ . From Eq. 1, the temperature sensitivity is given by

$$\frac{\partial \lambda_N}{\partial T} = \lambda_N \left( \frac{1}{n} \frac{\partial n}{\partial T} + \frac{1}{L} \frac{\partial L}{\partial T} \right) \quad \text{Eq. 2}$$

Although Eqs. 1 and 2 only depict one of the multiple peaks in the reflected spectrum from the sensor, in some cases, an average wavelength may be applied to significantly reduce the noise level or increase the resolution. This average wavelength can be obtained from multiple peaks or valleys or both.

The sensitivity depends on the TOC and the thermo-expansion coefficient (TEC) of the sensing material. The TOC and TEC for silicon are, respectively,  $1.5 \times 10^{-4}$  RIU/ $^{\circ}$ C. and  $2.55 \times 10^{-6}$  m/(m. $^{\circ}$  C.) at 25 $^{\circ}$  C. To estimate the sensitivity, these values are applied to Eq. (2) at the peak wavelength  $\lambda_N$  around 1550 nm and the RI of silicon is assumed to be 3.4. From this, the sensitivity of the temperature sensor proposed here is estimated to be 72 pm/ $^{\circ}$  C. As a comparison to the all-fiber based sensor, the TOC and TEC for fused silica are, respectively,  $1.28 \times 10^{-5}$  RIU/ $^{\circ}$  C. and  $5.5 \times 10^{-7}$  m/(m. $^{\circ}$  C.) at 25 $^{\circ}$  C., both of which are much smaller than those for silicon. Assuming the RI of silica at 1550 nm is 1.5, the sensitivity of an all-fiber based sensor is about 14 pm/ $^{\circ}$  C., which is more than 5 times smaller than the fiber optic sensor **100**.

The high RI (about 3.4) of silicon over infrared wavelength range produces a high reflectivity at the interfaces between silicon layer **108** and the surrounding environment and between silicon layer **108** and the fiber end face **152**, which facilitates to obtain a large optical power and a high fringe-visibility of the interferometric spectrum from the FP cavity for improving the sensor resolution. In addition, the high RI and the relatively long FP cavity yield a large number of fringes within the wavelength range of the spectrometer, which can be exploited to further increase the temperature resolution.

The fiber optic sensor **100** also features a short response time. Due to the high thermal diffusivity of silicon and the small size of the sensor head, the temperature within the FP cavity can quickly reach equilibrium with surroundings.

As illustrated in FIG. 1B, the fiber optic sensing system **130** can include a controller **132** that is configured to determine a shift in spectra detected by spectrometer **128** using a fiber optic sensor **100**. The controller **132** can be coupled to the components of the fiber optic sensing system **130**. Additionally, the controller **132** may be configured in a variety of ways. As illustrated in FIG. 1F, the controller **132** is illustrated as including a processor **134**, a memory **136**, and a communications interface **138**. The processor **134** provides processing functionality for the fiber optic sensor **100** and may include any number of processors, micro-controllers, or other processing systems, and resident or external memory for storing data and other information accessed or generated by the fiber optic sensor **100**. The

processor **134** may execute one or more software programs that implement the techniques and modules described herein. The processor **134** is not limited by the materials from which it is formed or the processing mechanisms employed therein and, as such, may be implemented via semiconductor(s) and/or transistors (e.g., electronic integrated circuits (ICs)), and so forth.

The memory **136** is an example of a non-transitory computer storage device that provides storage functionality to store various data associated with the operation of the fiber optic sensor **100**, such as the software program and code segments mentioned above, computer instructions, and/or other data to instruct the processor **134** and other elements of the fiber optic sensor **100** to perform the techniques described herein. Although a single memory **136** is shown, a wide variety of types and combinations of memory may be employed. The memory **136** may be integral with the processor **134**, stand-alone memory, or a combination of both. The memory may include, for example, removable and non-removable memory elements such as RAM, ROM, Flash (e.g., SD Card, mini-SD card, micro-SD Card), magnetic, optical, USB memory devices, and so forth.

The communications interface **138** is operatively configured to communicate with components of the fiber optic sensor **100**. For example, the communications interface **138** can be configured to transmit data for storage in the controller **132**, retrieve data from storage in the controller **132**, and so forth. The communications interface **138** is also communicatively coupled with the processor **134** to facilitate data transfer between components of the fiber optic sensing system **130** and the processor **134** (e.g., for communicating inputs to the processor **134** received from a device communicatively coupled with the fiber optic sensing system **130**). It should be noted that while the communications interface **138** is described as a component of fiber optic sensing system **130**, one or more components of the communications interface **138** can be implemented as external components communicatively coupled to the fiber optic sensing system **130** via a wired and/or wireless connection. The fiber optic sensing system **130** can also comprise and/or connect to one or more input/output (I/O) devices (e.g., via the communications interface **138**) including, but not necessarily limited to a display, a mouse, a touchpad, a keyboard, and so on.

The communications interface **138** and/or the processor **134** can be configured to communicate with a variety of different networks including, but not necessarily limited to: a wide-area cellular telephone network, such as a 3G cellular network, a 4G cellular network, or a global system for mobile communications (GSM) network; a wireless computer communications network, such as a WiFi network (e.g., a wireless local area network (WLAN) operated using IEEE 802.11 network standards); an internet; the Internet; a wide area network (WAN); a local area network (LAN); a personal area network (PAN) (e.g., a wireless personal area network (WPAN) operated using IEEE 802.15 network standards); a public telephone network; an extranet; an intranet; and so on. However, this list is provided by way of example only and is not meant to be restrictive of the present disclosure. Further, the communications interface **138** can be configured to communicate with a single network or multiple networks across different access points.

In one specific embodiment illustrated in FIGS. 1G through 1I, the fiber optic sensor **100** can function as a fiber optic anemometer. In this embodiment, the transmitted light **140** (e.g., white-light centered at 1550 nm) is injected

through the optical fiber **102** to the FP defined in the fiber optic sensor **100** by the optical fiber **102** and the silicon layer **108**, and the reflection spectrum of the reflected light **162** can be recorded by a high-speed spectrometer **128**. At the same time, heating light **142** from a heating light source **146** (e.g., 635 nm diode laser) can be guided through the same optical fiber **102** to the heat the FP. Silicon has a band gap energy of 1.11 eV and is highly transparent to the transmitted light **140** but is opaque to the heating light **142**. Therefore, the FP temperature can be effectively increased by the heating light **142**. When air moves (e.g., air convection **144**) over the surface of a hot silicon layer **108**, a cooling effect from the moving air reduces the temperature of the silicon layer **108** and the FP and introduces a shift to the fringe valley wavelength of the reflection spectrum, as schematically shown in FIGS. 1H and 1I. The wavelength shift can be separated by the spectrometer **128** and/or the controller **132** into a wind-temperature-induced wavelength shift and a wind-speed-induced wavelength shift. As a result, temperature self-compensated measurement of wind speed can be achieved by comparing the shift in the wavelengths of a fringe valley when the heating laser is turned on and off to determine temperature-compensated wind speed. It should be pointed out that although it is implemented as an anemometer in this example, it is not limited to measuring only the wind or air flow. Any other kind of flows (e.g., water flow) that can bring about the cooling effects to the heated sensor head can be measured.

#### Example Processes

The following discussion describes example techniques for utilizing a fiber optic sensor and fiber optic sensing system, such as the fiber optic sensor **100** and fiber optic sensing system **130** described in FIGS. 1A through 1I. FIG. 2A depicts an example process **200** for fabricating the fiber optic sensor **100**.

As shown in FIG. 2A, a light source is caused to transmit light through a fiber optic to a fiber optic sensor (Block **202**). In this implementation, controller **132** can cause light source **126** to transmit light (e.g., transmitted light **140**) through optical fiber **102** and circulator **124** to fiber optic sensor **100**. Controller **132** can control the duration and intensity that the light source **126** transmits the transmitted light **140**. In some specific implementations, controller **132** can cause heating light source **146** to transmit heating light **142** through the optical fiber **102** to the fiber optic sensor **100** and the silicon layer **108** for providing heat.

Reflected light from the fiber optic sensor is received using a spectrometer (Block **204**). The spectrometer **128** can receive the reflected light **162** and associated spectra, which can be recorded and/or analyzed by spectrometer **128** and/or controller **132**.

An output from the spectrometer is analyzed based on the received reflected light (Block **206**). In implementations, the controller **132** and/or the spectrometer **128** can analyze the reflected light **162** and the spectra to determine a wavelength shift in the spectra, which indicates a change in temperature. A variety of methods may be utilized to analyze and/or determine the wavelength shift in the spectra and for tracking the average wavelength. In a specific embodiment, analyzing an output from the spectrometer based on received reflected light can include using an average wavelength tracking method to further increase the resolution of wavelength and/or measurand.

The following discussion describes example techniques for fabricating a fiber optic sensor, such as the fiber optic sensor **100** described in FIGS. 1A through 1I. FIG. 2B depicts an example process **300** for fabricating the fiber



optic sensor **100**. FIGS. **3A** through **3E** illustrate a section an exemplary fiber optic sensor **100** during fabrication (such as the fiber optic sensors **100** described in FIGS. **1A** through **1I**).

As shown in FIG. **2B**, a silicon pillar is formed on a silicon substrate (Block **302**). FIG. **3A** illustrates forming at least one silicon pillar **150** that will function as a sensor head for the fiber optic sensor **100**. In one specific implementation, a double-side-polished silicon wafer (e.g., 200  $\mu\text{m}$  thick) can be bonded on top of another larger silicon wafer using a layer of photoresist **154**. The larger silicon wafer can function as a silicon substrate **148** to facilitate the fabrication and later as a support for the fabricated silicon pillar **150**. Then another layer of photoresist **154** can be coated on the top of the double-side-polished silicon wafer and patterned accordingly using photolithography techniques. The patterned top silicon layer can be etched all the way to the silicon substrate **148** and the second layer of photoresist **154** using, for example, deep-reactive-ion-etching, leaving the upstanding silicon pillar(s) **150** attached to the silicon substrate **148**.

Then, a thin film adhesive is formed on a glass substrate (Block **304**). In some specific embodiments, such as the one illustrated in FIG. **3B**, an adhesive **156** including a thin film of UV-curable glue can be spin-coated on a piece of glass substrate **158**. It is contemplated that forming a thin film adhesive **156** may include using other adhesives and/or other methods for depositing and/or forming the adhesive **156**. In embodiments, the adhesive **156** may include a thin film adhesive (e.g., UV-curable glue, an epoxy-based adhesive, and/or a gel-based adhesive).

Shown in FIG. **3C**, an end face of an optical fiber is pressed onto the thin film adhesive (Block **306**). In implementations, the adhesive **156** can be transferred to a cleaved and cleaned end face **152** of an optical fiber **102** by pressing the end face **152** of the optical fiber **102** to the adhesive **156** on the glass substrate **158**. Subsequently, the end face **152** and the adhesive **156** can be released from the glass substrate **158**.

As illustrated in FIGS. **3D** and **3E**, the optical thin film adhesive on the end face is placed onto the silicon pillar to provide the fiber optic sensor (Block **308**). The optical fiber **102** with the silicon pillar **150** (silicon layer **108**) attached can be lifted from the silicon substrate **148** and the second layer of photoresist **154**. Further, fabrication of the fiber optic sensor **100** may include cleaning residual photoresist **154** from the end of the silicon pillar **150** (e.g., with alcohol). Due to the ultra-thin thickness of the residual photoresist **154** between the optical fiber **102** and the silicon pillar **150**/silicon layer **108**, the reflection spectrum of the FP cavity within the fiber optic sensor **100** is not affected.

Then, the thin film adhesive is cured (Block **310**). In implementations, the adhesive **156** can be cured, for example, by UV irradiation (e.g., UV light **160**). It is contemplated that other bonding technology may be implemented to mount the silicon layer **108** (or other material) to the end face **152** of the optical fiber **102**, such as physical contact bonding.

It is contemplated that the above steps may be repeated to form a fiber optic sensor **100** with cascaded Fabry-Pérot cavities. For example, the optical fiber **102** with the silicon pillar **150** may be further pressed onto a second adhesive **166** on a glass substrate, placed on a second silicon pillar (e.g., second silicon layer **168**), and cured using UV light, to form a fiber optic sensor **100** with two Fabry-Pérot interferometers. Further Fabry-Pérot interferometers may be fabricated by repeating the above steps.

## Conclusion

Although the subject matter has been described in language specific to structural features and/or process operations, it is to be understood that the subject matter defined in the appended claims is not necessarily limited to the specific features or acts described above. Rather, the specific features and acts described above are disclosed as example forms of implementing the claims.

What is claimed is:

1. A fiber optic sensor, comprising:

an optical fiber configured to be coupled to a light source and a spectrometer; and

a first silicon layer disposed on an end face of the optical fiber, where the first silicon layer defines a Fabry-Pérot interferometer and a sensor head, where the sensor head reflects light from the light source to the spectrometer, and where the first layer includes a double sided-polished silicon pillar less than approximately 200  $\mu\text{m}$  in length.

2. The fiber optic sensor of claim 1, wherein the optical fiber includes a fused silica single mode fiber.

3. The fiber optic sensor of claim 1, wherein the optical fiber includes a circulator.

4. The fiber optic sensor of claim 1, wherein the first silicon layer has a diameter approximately the same as a diameter of the optical fiber.

5. The fiber optic sensor of claim 1, further comprising: the light source coupled to the optical fiber; the spectrometer coupled to the optical fiber; and a controller coupled to the spectrometer.

6. The fiber optic sensor of claim 5, wherein the spectrometer is based on a transmission grating and a diode array operating in the 1550 nm wavelength window.

7. The fiber optic sensor of claim 1, further comprising: a heating light source coupled to the optical fiber.

8. The fiber optic sensor of claim 7, wherein the heating light source includes a short wavelength diode laser.

9. A process for fabricating a fiber optic sensor, comprising:

forming at least one silicon pillar on a silicon substrate; forming a thin film adhesive on a glass substrate; pressing an end face of an optical fiber onto the thin film adhesive and releasing;

placing the thin film adhesive on the end face onto the at least one silicon pillar; and

curing the thin film adhesive to form the fiber optic sensor.

10. The process for fabricating the fiber optic sensor in claim 9, wherein the at least one silicon pillar is approximately 80  $\mu\text{m}$  in diameter and approximately 200  $\mu\text{m}$  in length.

11. The process for fabricating the fiber optic sensor in claim 9, wherein the at least one silicon pillar includes a metal coating disposed on an end face of the at least one silicon pillar that is distal from the optical fiber.

12. The process for fabricating the fiber optic sensor in claim 9, wherein the thin film adhesive includes at least one of a UV-curable glue, an epoxy-based adhesive, or a gel-based adhesive.

13. A fiber optic sensor, comprising:

an optical fiber configured to be coupled to a light source and a spectrometer; and

a first silicon layer disposed on an end face of the optical fiber, where the first silicon layer defines a Fabry-Pérot interferometer and a sensor head, where the sensor head reflects light from the light source to the spectrometer,

wherein the first silicon layer includes a double sided-polished silicon pillar with a diameter less than approximately 100  $\mu\text{m}$ .

14. A fiber optic sensor, comprising:  
an optical fiber configured to be coupled to a light source 5  
and a spectrometer;  
a first silicon layer disposed on an end face of the optical fiber, where the first silicon layer defines a Fabry-Pérot interferometer and a sensor head, where the sensor head reflects light from the light source to the spectrometer; 10  
and  
a second silicon layer disposed on the first silicon layer, where a first silicon layer length is different from a second silicon layer length.

\* \* \* \* \*