

Advanced Manufacturing: Polymer & Composites Science

ISSN: 2055-0340 (Print) 2055-0359 (Online) Journal homepage: <https://www.tandfonline.com/loi/yadm20>

A reference specimen for compaction tests of fiber reinforcements

David May, Florian Kühn, Matt Etchells, Ewald Fauster, Andreas Endruweit & Cristian Lira

To cite this article: David May, Florian Kühn, Matt Etchells, Ewald Fauster, Andreas Endruweit & Cristian Lira (2019): A reference specimen for compaction tests of fiber reinforcements, *Advanced Manufacturing: Polymer & Composites Science*, DOI: [10.1080/20550340.2019.1701826](https://doi.org/10.1080/20550340.2019.1701826)

To link to this article: <https://doi.org/10.1080/20550340.2019.1701826>



© 2019 The Author(s). Published by Informa UK Limited, trading as Taylor & Francis Group



Published online: 13 Dec 2019.



Submit your article to this journal [↗](#)



Article views: 27





View related articles [↗](#)



View Crossmark data [↗](#)

A reference specimen for compaction tests of fiber reinforcements

David May^a , Florian Kühn^a, Matt Etchells^b, Ewald Fauster^c , Andreas Endrweit^d and Cristian Lira^b

^aInstitut Für Verbundwerkstoffe GmbH, Kaiserslautern, Germany; ^bNational Composites Centre (NCC), Bristol, UK; ^cProcessing of Composites Group, Montanuniversität Leoben, Leoben, Austria; ^dFaculty of Engineering, Advanced Manufacturing Building (AMB), University of Nottingham, Nottingham, UK

ABSTRACT

Compaction behavior of textiles has a major influence on the outcome of various manufacturing processes for fiber reinforced polymer composites. Nevertheless, no standard exists up to date which specifies test methods or test rigs. A recent international benchmark revealed high variation associated with the result data. This work is a very first step toward a reference specimen, allowing for an isolated view on variations attributed to the test rig mechanics. A specimen design is proposed, intended to show compaction characteristics similar to technical textiles in terms of transverse compaction pressure and corresponding displacement. The reference specimen was tested in a round-robin study comprising test rigs at four different European research institutions. While reproducibility of the compaction behavior on each of the test rigs was high, clear variations between the results gained with different test rigs were observed.

ARTICLE HISTORY

Received 15 November 2019
Accepted 28 November 2019

KEYWORDS

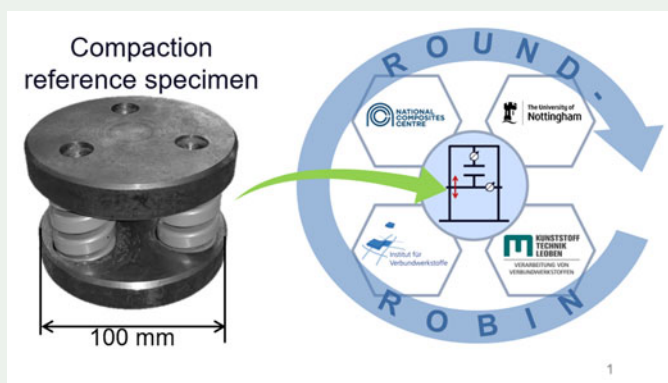

Liquid composite molding; compaction; textiles; fiber structures; testing



Introduction

Compaction response of fiber structures is of interest when it comes to designing manufacturing processes for fiber reinforced polymer composites. This is especially true for Liquid Composite Molding processes, such as vacuum infusion, where manually, machine or fluid pressure induced compaction takes place during preforming (dry) and impregnation (dry and wet). To determine the compaction response, tests on universal testing machines (UTM) are typically performed. The sample is compressed under defined boundary conditions (compaction velocity, holding and relaxation time), with compaction pressure required to reach a predefined sample thickness recorded. There is no standard, neither for the test rig nor for the test method. UTMs are normally calibrated on a regular

base and therefore offer high accuracy. Nevertheless, variations can result from the exact setup as shown e.g. by [1]. A recently conducted benchmark study revealed significant differences between the results gained at different research sites, even though the basic test method and sample lay-up were pre-defined [2]. To minimize variation, the specific sources need to be identified. Material- and sensor-inherent statistical variations must be distinguished from systematic deviations caused e.g. by the mechanical setting of the setup. At this point, reference specimens become relevant, as they allow an isolation of systematic effects, if they meet requirements such as consistency concerning the characteristics of interest, robustness against varying environmental conditions, and a high similarity of characteristics to 'real' samples. In fiber materials with

CONTACT David May  david.may@ivw.uni-kl.de  Institut Für Verbundwerkstoffe GmbH, Erwin-Schrödinger-Str. 58, Kaiserslautern, 67663 Germany

© 2019 The Author(s). Published by Informa UK Limited, trading as Taylor & Francis Group.

This is an Open Access article distributed under the terms of the Creative Commons Attribution License (<http://creativecommons.org/licenses/by/4.0/>), which permits unrestricted use, distribution, and reproduction in any medium, provided the original work is properly cited.

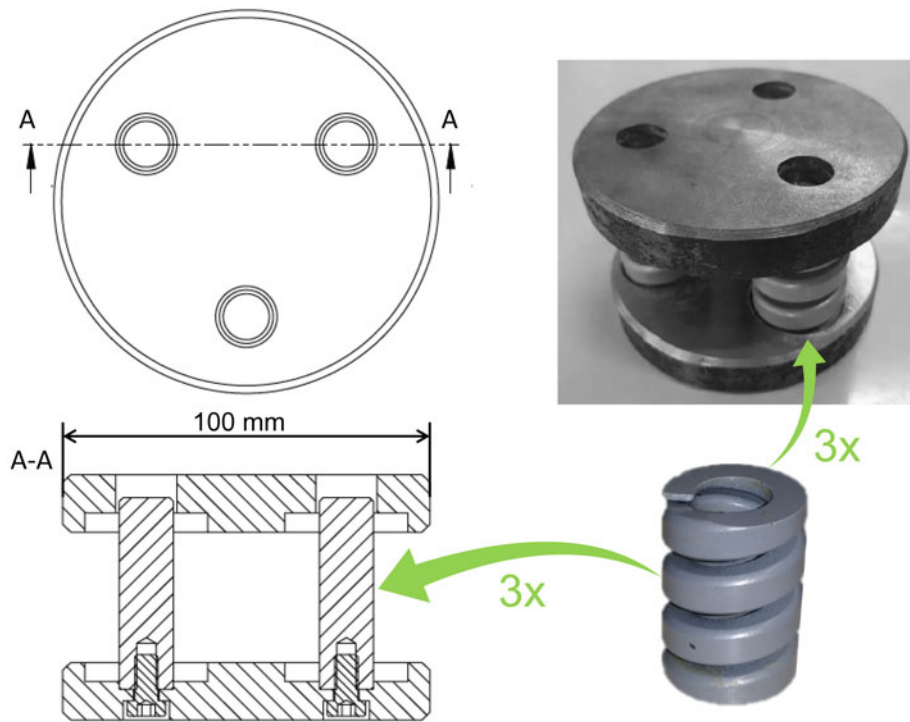

Figure 1. Technical drawing and picture of the specimen.

dual-scale porosity, such as woven or non-crimp fabrics, effects such as yarn bending, straightening, compression, and deformation as well as nesting effects interact, leading to non-linear elastic or even elasto-visco-plastic behavior [3]. To the authors' best knowledge, no reference specimen aiming to imitate this behavior has been suggested so far. This article presents a preliminary design for such a reference specimen, as well as a round-robin study to evaluate its functionality.

Experimentation

A single reference specimen (Figure 1) was manufactured, which was subsequently tested at four different research institutions. This way complexity is reduced by excluding the effect of manufacturing induced-variations. However, the design is also kept simple with the intention to minimize manufacturing-induced effects and thereby allowing decentralized benchmarking with individually build systems in the future. The target was to imitate the modulus of a conventional technical textile, while in this first attempt neglecting effects, such as time-dependency. As a reference the behavior of the woven fabric in the international benchmark study was considered [2]. The specimen provides a top and a bottom plate with three screw springs (Meusburger E1546/32 × 44, nominal stiffness 1300 N/mm). Adaption to other material types which show strongly differing behavior could be managed by changing the springs. The top plate rests on the springs (contact zones slightly lubricated) and is free in its vertical

movement, while horizontal movements are constrained by the pins (slightly lubricated). The total uncompacted height is 68 mm, the overall diameter is 100 mm.

Two test series were performed on the same reference specimen, using each research institutions respective test rig. In a first test series, the specimen is compacted at 1 mm/min up to a maximum force of 1 kN. The position at which maximum force is first reached is then held for 120 s and subsequently de-compaction follows with 1 mm/min. The second test series is largely identical, but the maximum force is 20 kN. Each series comprises five repeat tests (10 at MUL).

Test rigs similar to those used for testing of technical textiles were applied, without methods such as digital image correlation, as this is not common. All rigs are based on a UTM (IVW – Zwick 1485, MUL – UTS EuroTest 250, NCC – Zwick 1478, UoN – Instron 5969), where the sample is compacted between two plates, capturing (a) the force required to move these plates by means of load cells and (b) the relative position of the plates. The test rigs of MUL and UoN provide linear variable differential transformers directly measuring the distance between the plates. At IVW and NCC the crosshead position is used for the calculation of the specimen thickness. To account for inherent deformation, blind tests are performed before each test series, that is, the compaction plates are pressed on each other without a sample in between. The corresponding blind curves indicate the force-dependent error in crosshead position measurement and are used to

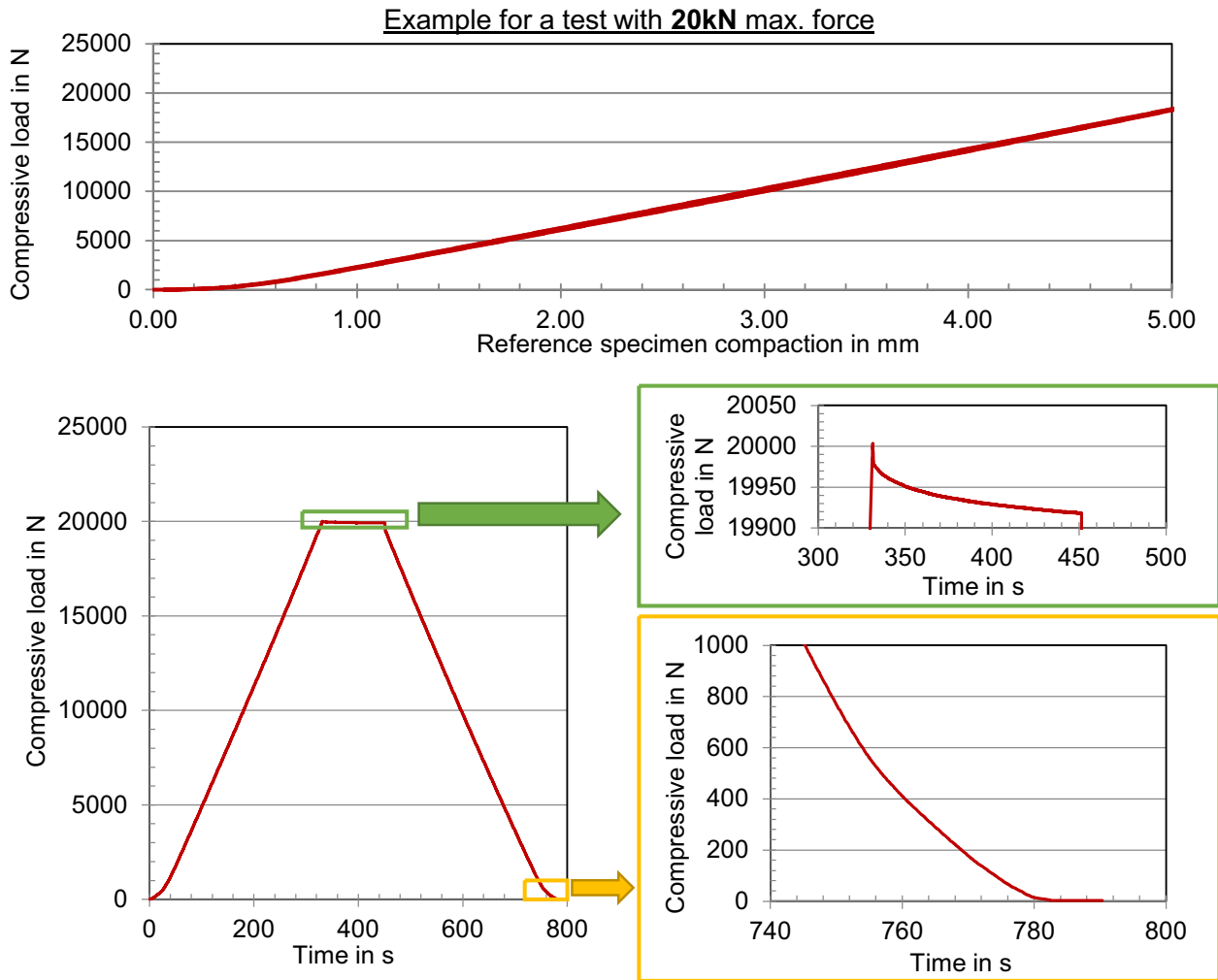

Figure 2. Exemplary compaction response of the specimen.

correct the displacement measurement in the tests with the specimen.

Results

The general compaction behavior of the specimen can be seen by the exemplary diagrams in Figure 2. The diagrams show examples for the results from the 20 kN tests.

The non-linear relation between the compaction force and the thickness reduction, which is observed up to 1 kN compaction force, is assumed to be spring-inherent. Above 1 kN, the correlation is linear. During the holding time, slight relaxation can be observed, potentially indicating mechanical setting in the contact zones between springs and plates. The slight hysteresis is a direct result of the relaxation. Non-linearity and relaxation do not affect the usability of the specimen as long as the behavior is reproducible.

To evaluate reproducibility, three values are considered for each test rig. The variation of the specimen compaction length (deviation from initial, uncompacted height) when the maximum force of

1 kN or 20 kN is reached, as well as the force measured at a compaction of 3 mm.

Table 1 shows the corresponding arithmetic average and coefficient of variation (cv) out of the five repetition tests. Reproducibility is very high for all test rigs, not only for the listed data points but also for the non-linear and relaxation effects. The same values allow evaluation of the comparability among the different test rigs, by calculating the overall cv between the participants average values (Table 1, last line). The variations between the results from the different test rigs are higher than the variations between the repetition tests on the single test rigs. Figure 3 shows all force vs. compaction curves measured with the different test rigs (only compaction, no de-compaction) and also clearly shows the differences. This indicates variations induced by the test rigs and the method. A potential source might be given by the different position measurement methods. Naturally, further research will have to reliably exclude the possibility that aging of the specimen, planarity of the specimen surface, clamping/positioning of the specimen are an issue in this context.

Table 1. Reproducibility considerations for the specimen.

Participant	Compaction at 1 kN		Compaction at 20 kN		Force at 3 mm compaction	
	Avg. in mm	cv in %	Avg. in mm	cv in %	Avg. in kN	cv in %
IVW	0.63	1.91	5.38	0.28	10371.45	0.61
MUL	0.49	0.07	5.32	0.06	10522.28	0.07
NCC	0.55	0.32	5.23	0.04	10693.00	0.19
UoN	0.57	0.28	5.37	0.06	10250.58	0.00
Total Avg.	0.56		5.33		10459.33	
cv in %	8.93		1.10		1.58	

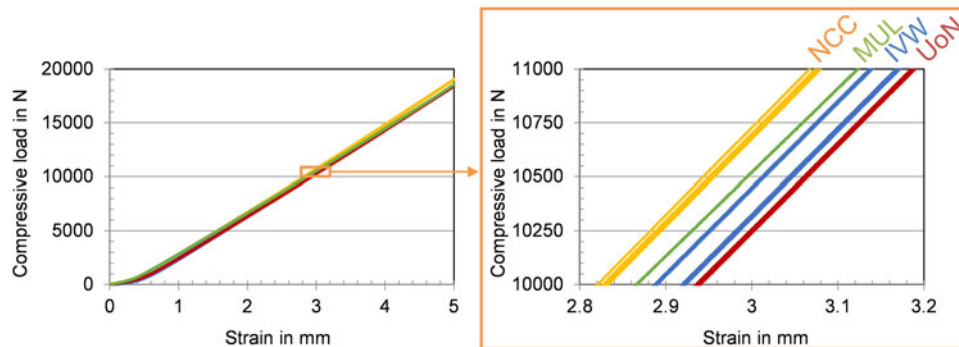
**Figure 3.** Comparison of the force vs. compaction curves (max. force: 20 kN) measured with the different test rigs.

Conclusions

The reference specimen roughly suits the modulus of typical technical textiles and shows high reproducibility. Further studies will have to deal with questions of time-dependency of the specimen characteristics. Also, a possible re-design will have to face the challenge to imitate the sensitivity of textile stacks to compaction between plates with deviations from plane-parallelism.

Acknowledgement

We also thank Florian Schüller (MUL) as well as Dmitry Ivanov and Arjun Radhakrishnan from University of Bristol.

Funding

The work performed at MUL has been elaborated in the project 'MoVeTech', financed through the Austrian Ministry for Transport, Innovation and Technology in the frame of the program 'Take Off'. The work performed at NCC has been developed in the Large Scale Resin

Infusion (LSRI) project, financed through UKRI (Innovate UK) as part of the 'HiStruct' project.

ORCID

David May  <http://orcid.org/0000-0002-5379-3708>

Ewald Fauster  <http://orcid.org/0000-0002-5838-6765>

References

- [1] Sousa P, Ivens J, Lomov SV. Methodology Of Dry And Wet Compressibility Measurement. 14th International Conference on Flow Processes in Composite Materials (FPCM); 2018 May 30–June 1; Lulea, Sweden.
- [2] May D, Aktas A, Yong A. International benchmark exercises on textile permeability and compressibility characterization. 18th European Conference on Composite Materials; June 25–28; Athens, Greece, 2018.
- [3] Bickerton S, Buntain M, Somashekar A. The viscoelastic compression behavior of liquid composite molding preforms. *Compos A Appl Sci Manuf.* 2003;34:431–444.