

## NUMERICAL SIMULATION OF FRICTION STIR WELDING

by

**Miroslav MIJAJLOVIĆ, Dragan MILČIĆ\*, and Miodrag MILČIĆ**

Mechanical Engineering Faculty, University of Nis, Nis, Serbia

Original scientific paper  
DOI: 10.2298/TSC1403967M

*Friction stir welding is a solid-state welding technique that utilizes thermo-mechanical influence of the rotating welding tool on parent material resulting with monolith joint-weld. On the contact of welding tool and parent material, significant stirring and deformation of parent material appears, and during this process mechanical energy is partially transformed into heat. The paper describes the software for the numerical simulation of friction stir welding developed at Mechanical Engineering Faculty, University of Nis. Numerical solution for estimation of welding plates temperature is estimated using finite difference method-explicit scheme with adaptive grid, considering influence of temperature on material's conductivity, contact conditions between welding tool and parent material, material flow around welding tool etc. The calculated results are in good agreement with the experimental results.*

Key words: *numerical simulation, friction stir welding, finite difference method, numerical method*

### Introduction

In recent years, friction stir welding (FSW), which was invented at Welding Institute (TWI) [1], has emerged as an excellent technique for joining aluminum structures that are difficult to be welded with the traditional fusion welding technique. This process uses a specially designed rotating pin that is first inserted into the adjoining edges of the blank sheets with a proper tilt angle and then moved all along the welding line. Such a pin produces frictional and plastic deformation heating in the welding zone; actually, no melting of material is observed in FSW. Furthermore, as the tool moves, material is forced to flow around the tool in a quite complex flow pattern.

In comparison with analytical calculations, numerical methods allow the better adjustment of data to real conditions accompanying FSW, *i. e.* the geometry of elements being welded, dependences of material physical properties on temperature, heat losses, and the distribution of heat sources, including friction-induced heating.

The most commonly applied are finite element methods and finite difference methods. The numerical simulation of FSW/Friction stir processing (FSP) enables the determination of the temperature field, plasticised material motion, strain rate, joint hardness, microstructure, and strain levels.

---

\* Corresponding author; e-mail: [milcic@masfak.ni.ac.rs](mailto:milcic@masfak.ni.ac.rs), [dragan.milcic@gmail.com](mailto:dragan.milcic@gmail.com)

Modelling requires the use of such computational systems as ANSYS, Sysweld, Forge3, STAR CCM+, ABAQUS, AcuSolve, MSC-Marc, FLUENT, WELDSIM, DEFORM-3D, I-DEAS, NX, COMSOL, and Matlab.

Heat generation and heat transfer became a topic of research related to FSW during mid 1990. However, understanding heat generation and heat transfer processes within FSW requires understanding several other physical processes: material flow around the welding tool, contact pressure inflicted by the welding tool, the friction coefficient, wear, change of thermo-mechanical properties and heat transfer coefficients, *etc.* Nandan *et al.* [2] gives a review of thermal processes in FSW, from the invention of FSW until 2008. Chao and Qi [3] have introduced a 3-D heat transfer model in FSW with constant heat input. Constant heat flux at the shoulder of the welding tool, constant contact pressure and pure Coulomb's friction law for estimating shear stress, and heat were the main assumptions of the model. The experimental welding of plates made of aluminum alloy 6061-T6 was performed and the temperature history of welding plates was estimated. Heat input was adjusted ("trial and error" principle) until numerical and experimental temperatures were matched. As such, this model is the first model developed for estimating the amount of heat generated during FSW. Frigaard and Grong [4] presented a process model for heat flow in FSW, where they assumed that heat is generated only by friction on the tops of shoulders and probes. Heat input and friction coefficients were adjusted during the welding process to keep the calculated temperature below the melting point of base metal material. Heat input was a moving heat source with a linear distribution of heat flux at the contact surface. Gould and Feng [5], and later Russell and Shercliff [6], applied the Rosenthal equation [7] for describing the moving heat source, heat flux distribution, and heat transport within base metals, welding tools and the surrounding area. Models consider friction heat only at the shoulder and use a finite difference method for a numerical solution of the heat equation. Russell and Shercliff [6] based the heat generation on a constant friction stress equal to the shear yield stress at elevated temperature, which is set to 5% of the yield stress at room temperature. The heat input is a pure point or line source. Colegrove *et al.* [8] used an advanced analytical estimation of the heat generation on the welding tool with a threaded probe to estimate the heat generation distribution. The results show that the fraction of heat generated by the probe is about 20% of the total amount. Shercliff and Colegrove [9] developed a material flow model that investigates the influence of threads on the probe on material flow. An advanced viscous material model is introduced and the influence of different contact conditions prescribed as the boundary condition is analyzed. A thorough presentation of analytical estimates of the heat generation in FSW and influence of material flow on heat generation is given, as well. Khandkar *et al.* [10] introduced a torque based heat input model where experimentally estimated torque is a heat source. Khandkar modeled advanced heat transfer within the FSW process with frictional and deformational heat input into the process. Song and Kovačević [11] investigated the influence of the preheating period on the temperature fields in FSW. A sliding condition of the welding tool over the base metal was assumed and an effective friction coefficient and experimental plunge force are input into the heat source expression. Schmidt and Hattel [12] defined an analytical model for estimating the amount of heat generated during FSW that recognizes the shoulder and the probe of the welding tool as heat sources and concludes that about 89% of heat is generated at the shoulder. Heat has friction and deformation components and the total heat is a sum of both with influence of the contact state variable [12, 13]. The effective value of the friction coefficient was used in calculations. Reliability of the previously proposed ideas and principles of heat generation were summarized by Nandan *et al.* [14]. Nandan has performed FSW of dissimilar aluminum alloys and his results have shown that a constant state variable (also re-

ferred as an extent of slip) gives values close to sticking. Heurtier *et al.* [15] presented a 3-D model based on the fluid-velocity fields where the tool shoulder and the plastic strain of base material near the welding tool were heat sources. The model has shown good agreement regarding the numerical and experimental results. Santiago *et al.* [16] introduced a model with rigid and visco-plastic materials in which the plates move towards the rotating tool and the material flow at the interface is specified as a boundary condition. The results estimated from the model correspond to the steady-state of the FSW process that has been proposed by Chao [17]. Schmidt [18] and Veljić [19] are adopted a fully coupled thermo-mechanical dynamic analysis model also aiming to achieve the steady welding state in ABAQUS/Explicit. Colligan [20] gave a conceptual model that describes dominant parameters affecting heat generation including a detailed description of the existing literature and the principles of specific physical processes in FSW, *e. g.* friction coefficient.

### Friction stir welding

FSW consists mainly in three phases, in which each one can be described as a time period where the welding tool and the workpiece are moved relative to each other. In the first phase, the rotating tool is vertically displaced into the joint line (plunge period). This period is followed by the dwell period in which the tool is held steady relative to the workpiece but still rotating. Owing to the velocity difference between the rotating tool and the stationary workpiece, the mechanical interaction produces heat by means of frictional work and material plastic deformation. This heat is dissipated into the neighboring material, promoting an increase of temperature and consequent material softening. After these two initial phases the welding operation can be initiated by moving either the tool or the workpiece relative to each other along the joint line. Figure 1 illustrates a schematic representation of the FSW set-up.

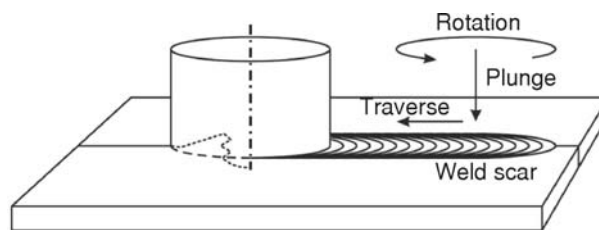

Figure 1. Principle of the FSW

Welding tool is rotated at a constant speed and fed at a constant traverse speed into the joint line between two welding plates (workpieces), which are butted together. The parts are clamped rigidly onto a backing plate (anvil) in a manner that prevents the abutting joint faces from being forced apart. The length of the probe is slightly less than the weld depth required and the tool shoulder should have contact with the work surface. The probe is moved against the weld-joint line, or *vice versa*. While traveling, welding tool stirs, deforms and mixes the material of the workpieces into the monolith mixture that represents the weld. Figure 2 presents a schematic example of an FSW tool with conical shoulder and threaded probe. In this case, the conical tool shoulder helps to establish a pressure under the shoulder, but also operates as an escape volume for the material displaced by the probe due to the plunge action.

As a solid state welding procedure, FSW uses pure mechanical energy as welding process activation energy and distributes it from the welding machine to the base material (workpieces) over the welding tool. However, only one part of the mechanical energy is used directly as a mechanical energy while the rest of it is transformed in other types of energy: into heat, light, electricity, radiation, *etc.* Researches, experience and engineering practice have

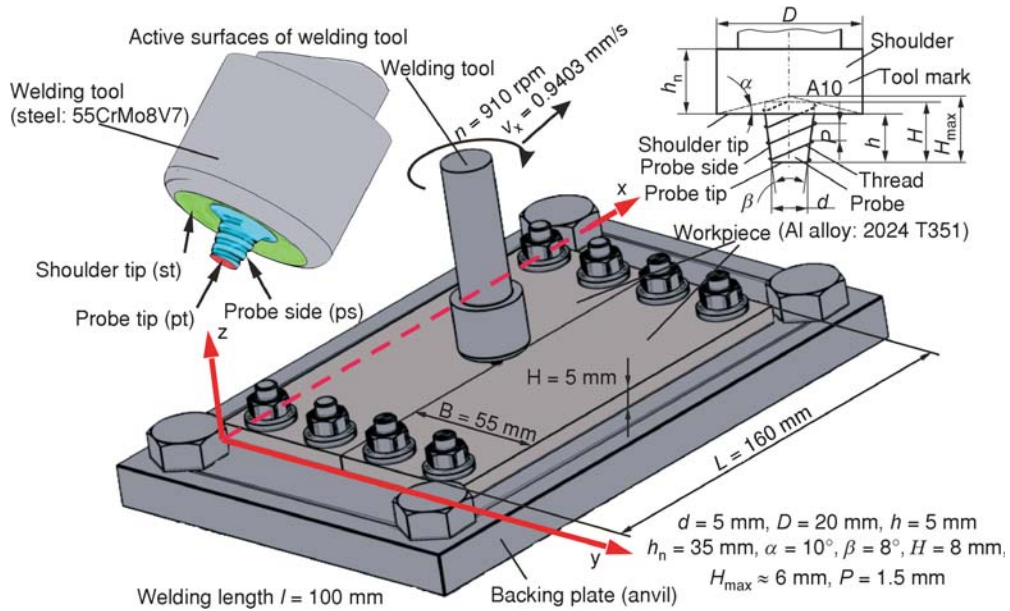

Figure 2. FSW tool with a conical shoulder and threaded probe [21]

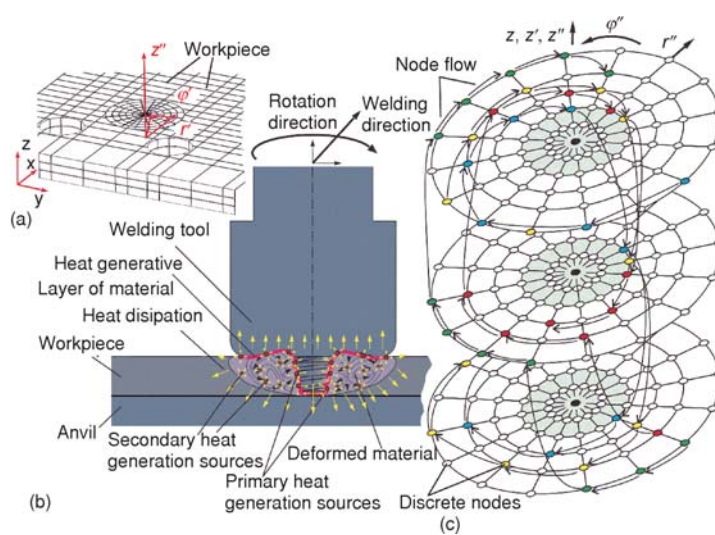

Figure 3. (a) Space discretization, (b) Heat generation, and (c) Numerical model material flow during FSW [22]

shown that, as a result of any kind of energy transformation, direct or indirect product of energy use is transformation of input energy into heat, partially or almost completely. This is a phenomenon that appears during the FSW process as well: mechanical energy given to the welding tool is dominantly used for deformation and mixing of the particles chopped from workpieces during contact of the welding tool and workpieces, the rest of energy is transforming into heat and some of it is transformed in other types of energy (fig. 3).

**Analytical model for estimation of amount of generated during FSW**

Heat generation process at FSW has been partially investigated at the beginning of 2002 for the first time. This happened 11 years after invention of the FSW.

Until present days, there are three (four) published analytical models for estimation and assessment of amount of heat generated during FSW [12, 23]. All of them differently approach to the heat generation in FSW, however, all of them consider heat generation in FSW as a process tightly connected with the contact mechanics, tribology, plastic deforming and thermodynamics of deformable bodies. These models show that 60% to 100% of the mechanical power transform into heat during FSW.

Analytical model developed at Faculty of Mechanical Engineering in Nis is the fourth published model for estimation of amount of heat generated during FSW [22-24]. As well as first three models, it relies on the conservation of mechanical energy postulate and starts from the assumption that in theory complete amount of mechanical energy delivered to the welding tool transforms into heat. In reality, one part of mechanical energy is used for other processes that appear during welding what gives that at most the rest of the mechanical energy can be transformed into heat. In order to estimate maximal possible amount of generated heat during FSW (for certain technological parameters of the process), this model takes into consideration influence of the welding tool to the process of welding, loads, tribological parameters, temperature of workpieces, material flow around the welding tool, heat generation mechanisms, *etc.*

### **Numerical simulation of FSW**

The process of heat generation in FSW process, as one of the scientific uncertainty related to the procedure itself, is difficult to account for. The established analytical model which describes the generation of heat during friction stir welding currently be confirmed only by comparing the results obtained from experimental studies with the results obtained by numerical simulation that implements developed an analytical model to determine the amount of heat generated in the FSW process.

However, the analytical model for determining the amount of heat generated is directly related to some quantities whose values are stochastic, insufficiently known or directly caused by the very process of welding. These sizes are force of penetration, coefficient of friction, temperature tools and workpieces during the welding process, the timing effects tools, duration, *etc.* Therefore, it would appear that the numerical simulation must introduce certain assumptions related to such a size and/or to use the experimentally determined values of these quantities. Schematic representation of the numerical simulation is shown in fig. 4.

Numerical simulation consists of three basic steps:

- preprocessing,
- processing, and
- postprocessing.

At the beginning of the simulation, based on the input data and knowledge base, software performs preprocessing. Then, perform the primary and secondary discretization space, to nodes and finite elements are assigned the appropriate properties (mechanical, thermal, tribological, *etc.*), defining the initial conditions and the borders depending on the moment of time for which a simulation is performed, *etc.* Secondary discretization is only part of the preprocessing is done in parallel with the processing depending on the phase of the welding that is numerically simulated. During the processing is carried out numerical calculation of temperature workpieces and tools using finite differences method. Size required for the calculation of temperature obtained on the basis of the analytical model and the knowledge base/database. The analytical model is used to determine parameters that directly and indirectly affect the determination of the amount of heat generated. Post-processing includes processing data from the pro-

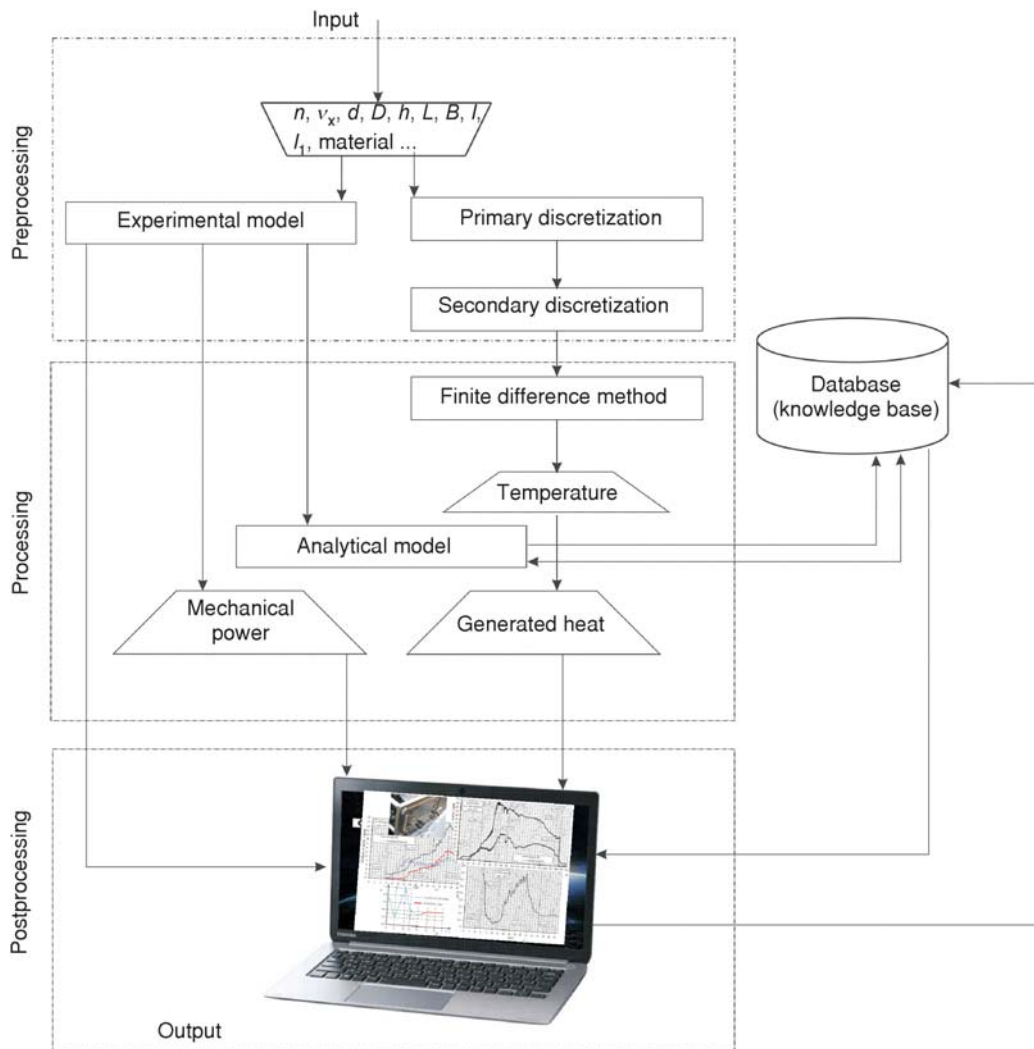

Figure 4. Schematic representation of numerical simulations of FSW

cessing phase, the comparison of experimental data with numerical and production of statistical data.

For the numerical simulation which determines the amount of heat generated during FSW procedure, it is necessary to separate the software for calculation because existing professional simulation software (ANSYS, ABACUS, Adams, *etc.*) are not fully able to meet the specific requirements were imposed an analytical model for determining the amount of heat generated.

The developed software must meet the following requirements.

- Entering and checking the consistency of all necessary geometric, mechanical, thermal, initial, boundary, and technological parameters, as well as other conditions before starting the simulation. This implies the input geometric measure workpieces (length, width, height),

tools (diameter, height), backing plate (length, width, height). Thereafter the input of mechanical properties of materials tools, workpieces and backing plate (Yield strength  $\sigma_{\text{yield}}$  as a function of temperature and strain, elastic modulus  $E$ , Poisson's number  $\nu$ , etc.), thermal properties of materials, initial conditions (temperature, pressure, preload, etc.), the boundary conditions of heat flow (metal-to-metal, metal-air, etc.) and technological parameters (tool rotation speed  $n$  [rpm] and travel rate  $v_x$  [mm/s], welding position, tilt angle, etc.).

- Record in operating memory and/or connect to the databases that contain the necessary experimental data about welding test with which it will be compared to the numerical results. The necessary experimental data are the beginnings/ends of the stage welding process ( $t_0$ ,  $t_1$ ,  $t_2$ ,  $t_{\text{st}}$ , etc.), the intensity of the axial force  $F_z(t)$  during the welding process, experimental value of the coefficient of friction  $\mu(t)$ , etc.
- Discretization of space that includes the tool, workpiece and backing plate and then check the convergence of the numerical calculations. The software asks the optimal dimensions of discretization elements to shorten the time calculation. Also, the software performs discretization of time within duration of the welding process.
- “Preprocessing” at which assigns the nodes and elements of the corresponding properties (mechanical and thermo-mechanical), initial and border conditions, depending on the moment the calculation is performed.
- Calculation of the required size (the contact pressure, the temperature, the amount of generated heat, etc.) in the nodes discretized space, in the discretized time, for the duration of the welding process.
- Simulation of material flow around the tool.
- Plotting the corresponding diagrams, figures and tables with the results of the calculation (the amount of generated heat, temperature, etc.).

Flow chart of an algorithm software is shown in fig. 5

Software for the numerical simulation of the FSW of aluminum alloy according to the proposed algorithm is developed at Faculty of Mechanical Engineering in Nis. The application is developed in Visual Basic 6 platform.

Material flow in FSW was explained by many [25-27], however, there is no adequate mathematical model capable to fully describe it. Present works on FSW either neglect the influence of material flow or simplify the material flow patterns considering it purely rotational around the welding tool. Faculty of Mechanical Engineering in Nis has proposed a new numerical procedure for implementation of material flow pattern into numerical simulations of FSW. Procedure is called – node substitution and replacement [22] and uses experimental results, probabilistic theory, technological parameters of the FSW, geometry of the FSW tool, etc. to estimate material flow pattern around the FSW tool. The main goal of the procedure was to improve accuracy of the numerical simulation.

All these procedures are numerical and when implemented in analytical model for heat estimation they are part of the numerical simulation of FSW that has a goal estimate amount of heat generated during FSW.

Table 1 shows some important parameters necessary for the numerical simulation.

In figs. 6, 7, and 8 are shown the results of numerical simulations of the FSW of 2024-T351 aluminum alloy (AA 2024-T351) – temperature welding plates, as a whole, and for each point in the welding plates – a certain level in certain moments of time. The simulation model is tested with experimental results. The calculated results are in good agreement with the experimental results [28].

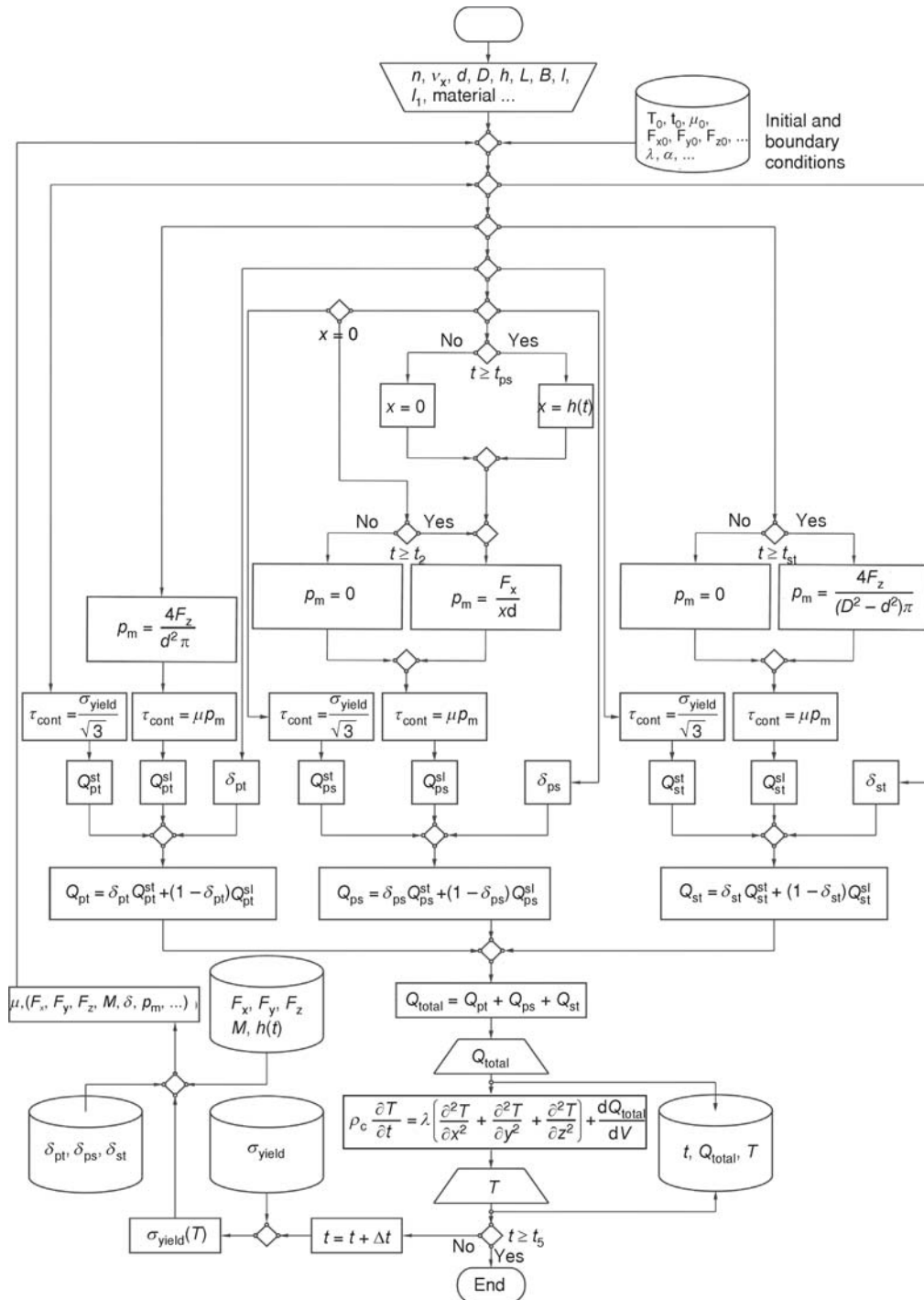

Figure 5. Flow chart of an algorithm software



**Table 1. Simulation parameters**

$T$ [°C]	24	100	149	204	260	316	371	400
$\sigma_{\text{yield}}(T)$ , [N/mm <sup>2</sup> ]/no plastic strain	345	331	310	138	62	41	28	21
$\sigma_{\text{yield}}(T, \varepsilon)$ , [N/mm <sup>2</sup> ]/plastic strain $\varepsilon$	483/0.18	455/0.16	379/0.11	186/0.23	76/0.55	52/0.75	34/1.00	25/1.00
Convection coefficient	$\alpha = 10 \text{ W/m}^2\text{K}$ , $\alpha_{\text{approx}} = 1500 \text{ W/m}^2\text{K}$							
Nominal TP* of welding plates	$\lambda_{\text{pt}} = 121 \text{ W/mK}$ , $\rho_{\text{pt}} = 2780 \text{ kg/m}^3$ , $c_{\text{pt}} = 875 \text{ J/kgK}$							
Nominal TP of welding tool	$\lambda_{\text{wt}} = 38 \text{ W/mK}$ , $\rho_{\text{wt}} = 7840 \text{ kg/m}^3$ , $c_{\text{wt}} = 500 \text{ J/kgK}$							
Material and diameter of bolts	S335 EN 10025, $d_z = 10 \text{ mm}$							
Nominal TP of bolts	$\lambda_{\text{bt}} = 43 \text{ W/(mK)}$ , $\rho_{\text{bt}} = 7850 \text{ kg/m}^3$ , $c_{\text{bt}} = 420 \text{ J/(kgK)}$							
Dimensions of welding plates	$L = 154 \text{ mm}$ , $B = 54 \text{ mm}$ , $h = 6 \text{ mm}$ , $l = 90 \text{ mm}$ (welded length)							
Important dimensions of welding tool	length $L_{\text{wt}} = 78 \text{ mm}$ , shoulder $D = 24 \text{ mm}$ , probe $d = 6 \text{ mm}$							
Material of welding tool	56NiCrMoV7 (UTOP 2), DIN 17350							
Technological parameters	$n = 910 \text{ rpm}$ , $s = 0.062 \text{ rpm}$ , $v_x = 0.9403 \text{ mm/s}$							
Nominal TP of anvil	$\lambda_a = 18 \text{ W/mK}$ , $\rho_a = 8030 \text{ kg/m}^3$ , $c_a = 500 \text{ J/kgK}$							
Minimal discretization dimensions/time step	$\Delta x_{\text{min}} = 3 \text{ mm}$ , $\Delta y_{\text{min}} = 1.5 \text{ mm}$ , $\Delta z_{\text{min}} = 1.5 \text{ mm}$ ; $\Delta t = 0.0055 \text{ s}$							
Adaptive discretization parameters	$\varepsilon_x = -1, 1, 5/3, 7/2$ ; $\varepsilon_y = -4/3, 1, 5/3, 2, 10/3, 16/3, 20/3$ ; $\varepsilon_z = -1, 1$ ;							
Convergence of FDM**	$\lambda_{\text{pt}} \Delta t / \rho_{\text{pt}} c_{\text{pt}} \Delta x_{\text{min}}^2 = 0.03 < 1/6 = 0.167$ $\lambda_{\text{pt}} \Delta t / \rho_{\text{pt}} c_{\text{pt}} \Delta y_{\text{min}}^2 = 0.122 < 1/6 = 0.167$ $\lambda_{\text{pt}} \Delta t / \rho_{\text{pt}} c_{\text{pt}} \Delta z_{\text{min}}^2 = 0.122 < 1/6 = 0.167$							
Number of nodes/iterations	$n_{\text{nod}} = 14160 / n_{\text{iter}} = 28528$							
Approximate calculation time	$t_{\text{calc}} = 1283760 \text{ s}$ (14 d 20 h 36 min) (processor: $2 \times 2.30 \text{ GHz}$ )							

\* TP – thermo-mechanical properties, \*\* FDM – finite difference method

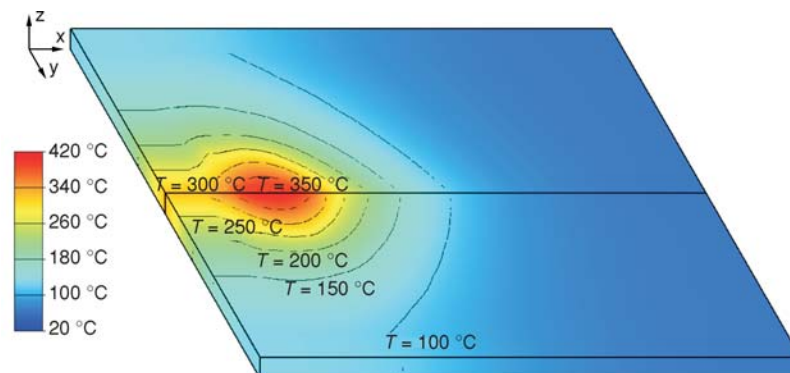

**Figure 6. Numerical certain temperature field work pieces, a moment  $t = 40.6285 \text{ s}$ , maximum temperature  $T_{\text{max}} = 393.538 \text{ °C}$  at the point with co-ordinates  $(x, y, z) = (30.5, 53, 4)$**

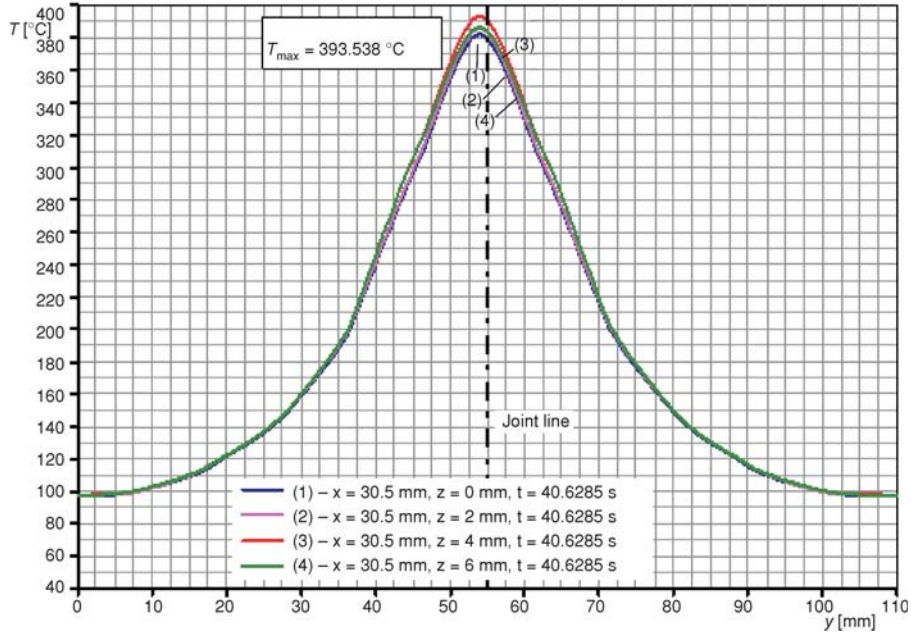

Figure 7. Numerical certain temperature workpieces in a plane perpendicular to the direction of the tool

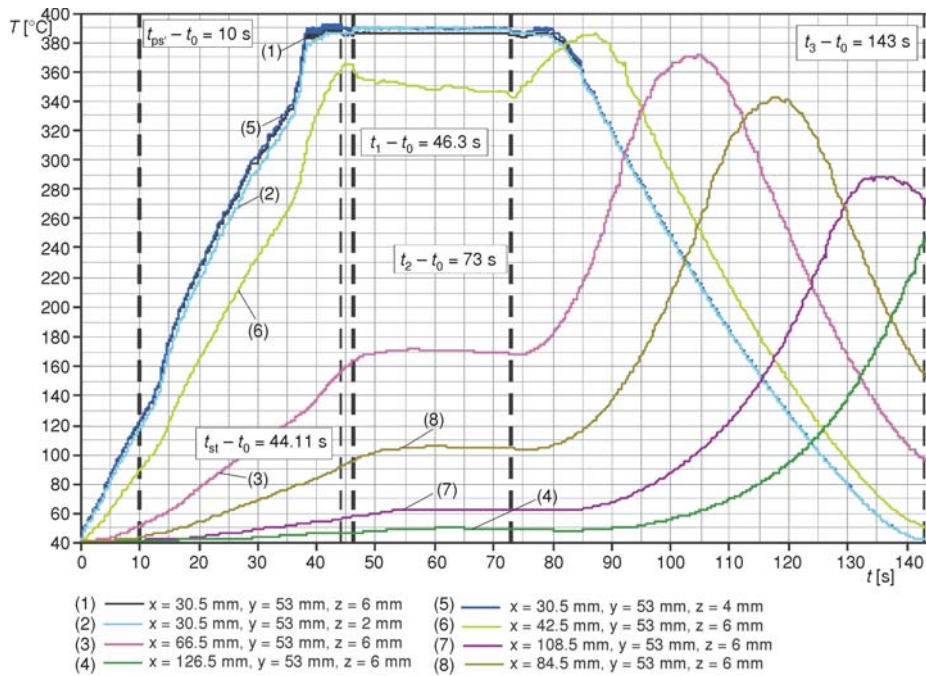

Figure 8. Numerical set-point temperature of individual workpieces during the welding

## Conclusions

A number of academic and industrial institutions have made efforts to develop numerical codes for FSW. Although FSW is simple in concept, the physics behind the process is complex, which includes mechanical heat generation, heat and mass transport. The large strains and strain rates make observing the details of the process difficult, which makes process modeling attractive or essential to understand it. The material database available in literature does not typically include the constitutive data required to describe this phenomenon. It is not possible to directly observe the material mixing and flow either.

The numerical code developed at the Faculty of Mechanical Engineering, University of Nis, is a synergy of experimental models, analytical models, and numerical calculations. Numerical simulation of FSW included well known finite difference method for numerical estimation of temperatures in discrete nodes of workpieces and accuracy of the simulation is improved by the innovative numerical method for material flow definition – node substitution and replacements.

The simulation model is tested with experimental results. The infrared camera captures images that show temperatures of bodies/space in the focus of camera, but the analytical/numerical method gives discrete values of temperatures in the entire volume. In order to compare experimental and numerical temperature, 24 control points were chosen on the top surface of the welding plates. Experimental temperatures of control points were estimated by adequate software from infrared images while numerical temperatures were estimated by interpolation of node temperature. The calculated results are in good agreement with the experimental results. Proposed analytical/numerical model for temperature estimation gave numerically estimated temperature that varies up to 11% from experimentally estimated temperature (that is about 15 °C as absolute error). Maximal temperature on welding plates was numerically estimated  $T_{\max} = 393,538$  °C, which is about 80% of AA 2024-T351 melting point. Maximal temperature of the welding tool was experimentally measured  $T_{\max} = 464$  °C.

Using the numerically calculated temperature field, the residual stress in friction stir welded plate can be determined.

## Acknowledgment

This paper is part of the technological project TR35034 “The research of modern non-conventional technologies application in manufacturing companies with the aim of increase efficiency of use, product quality, reduce of costs and save energy and materials” at the University of Nis, Faculty of Mechanical Engineering, and was supported by Ministry of Education, Science and Technological Development of the Republic of Serbia

## References

- [1] Thomas, W. M., Friction Stir Butt Welding, International Patent Application No. 9125978.8, 1991
- [2] Nandan, R. *et al.*, Recent Advances in Friction-Stir Welding – Process, Weldment Structure and Properties, *Progress in Mat. Sci.* 53 (2008), 6, pp. 980-1023
- [3] Chao, Y. J., Qi, X., Thermal and Thermo-Mechanical Modeling of Friction Stir Welding of Aluminum Alloy 6061-T6, *J. Mater. Proc. Mfg. Sci.*, 7 (1998), pp. 215-233
- [4] Frigaard, O., Grong, O., Modeling of the Heat Flow Phenomena in Friction Stir Welding of Aluminum Alloys, Paper presented at: INALCO '98. *Proceedings on CD*, 7<sup>th</sup> International Conference on Joints in Aluminum, Cambridge, UK, 1998
- [5] Gould, J. E., Feng, Z., Heat Flow Model for Friction Stir Welding of Aluminum Alloys, *Journal of Material Processing and Manufacturing Science.*, 7 (1998), pp. 185-194

- [6] Russell, M. J., Shercliff, H. R., Analytical Modeling of Microstructure Development in Friction Stir Welding, *Proceedings on CD*, 1<sup>st</sup> International Symposium on Friction Stir Welding, Thousand Oaks, Cal, USA, 1999
- [7] Rosenthal, D., The Theory of Moving Sources of Heat and its Application to Metal Treatments [J]. *Transaction ASME*, 43 (1946), 11, pp. 849-866
- [8] Colegrove, P. et al., 3-Dimensional Flow and Thermal Modeling of the Friction Stir Welding Process, *Proceedings on CD*, 2<sup>nd</sup> International Symposium on Friction Stir Welding, 2000, Gothenburg, Sweden
- [9] Shercliff, H. R., Colegrove, P. A., Modelling of Friction Stir Welding, in: *Mathematical Modelling of Weld Phenomena 6*, Maney Publishing, London, 2002, pp. 927-974
- [10] Khandkar, M. Z. H., et al., Prediction of Temperature Distribution and Thermal History during Friction Stir Welding: Input Torque Based Model, *Science and Technology of Welding & Joining.*, 8 (2003), 3, pp. 165-174
- [11] Song, M., Kovačević, R., Thermal Modeling of Friction Stir Welding in a Moving Coordinate and Its Validation, *Int. J. Machine Tool Manufacturing*, 43 (2003), 6, pp. 605-615
- [12] Schmidt, H. J., Hattel, J. W., An Analytical Model for the Heat Generation in Friction Stir Welding, *Model Simul. Mater. Sci. Eng.*, 12 (2004), pp. 143-157
- [13] Hamilton, C., et al., Thermal Model of Friction Stir Welding Applied to Sc-Modified Al-Zn-Mg-Cu Alloy Extrusions, *International Journal of Machine Tools and Manufacture*, 49 (2008), 3-4, pp. 230-238
- [14] Nandan, G. G., et al., Three-Dimensional Heat and Material Flow during Friction Stir Welding of Mild Steel, *Acta Materialia*, 55 (2007), pp. 883-895
- [15] Heurtier, P., et al., Mechanical and Thermal Modelling of Friction Stir Welding, *Journal of Materials Processing Technology*, 171 (2006), pp. 348-357
- [16] Santiago, D. H., et al., Numerical Modeling of Welded Joints by the Friction Stir Welding Process, *Materials Research*, 7 (2004), 4, pp. 569-574
- [17] Chao Y. J. et al., Heat Transfer in Friction Stir Welding-Experimental, and Numerical Studies, *Transactions of the ASME*, 125 (2003), pp. 138-145
- [18] Schmidt, H., Hattel, J., A Local Model for the Thermo-Mechanical Conditions in Friction Stir Welding, *Modelling and Simulation in Mat. Science and Eng.*, 13 (2005), pp. 77-93
- [19] Veljić, D., et al., A Coupled Thermo-Mechanical Model of Friction Stir Welding, *Thermal Science*, 16 (2012), Suppl. 2, pp. 527-534
- [20] Colligan, K. J., Mishra, R. S., A Conceptual Model for the Process Variables Related to Heat Generation in Friction Stir Welding of Aluminium, *Scripta Mat.*, 58 (2008), pp. 327-331
- [21] Mijajlović, M, et al., Experimental Studies of Parameters Affecting the Heat Generation in Friction Stir Welding Process, *Thermal Science*, 16 (2012), Suppl. 2, pp. 351-362
- [22] Mijajlović, M., Investigation and Development of Analytical Model for Estimation of Amount of Heat Generated During FSW, Ph. D. thesis, Faculty of Mechanical Engineering, University of Nis, Serbia, 2012
- [23] Mijajlović, M., et al., Mathematical Model for Analytical Estimation of Generated Heat During Friction Stir Welding, Part 1, *Journal of Balkan Tribological Association*, 17 (2011), 2, pp. 179-191
- [24] Mijajlović, M., et al., Mathematical Model for Analytical Estimation of Generated Heat During Friction Stir Welding, Part 2, *Journal of Balkan Tribological Association*, 17 (2011), 3, pp. 361-370
- [25] Colegrove, P. A., Shercliff, H. R., 3-Dimensional CDF Modelling of Flow Round a Threaded Friction Stir Welding Tool Profile, *J. Mater. Process. Tech.*, 169 (2005), 2, pp. 320-327
- [26] Nandan, R., et al., Three-Dimensional Heat and Material Flow During Friction Stir Welding of Mild Steel, *Acta Materialia*, 55 (2007), 3, pp. 883-895
- [27] Ouyang, J. H., Kovačić, R., Material Flow and Microstructure in the Friction Stir Butt Welds of the Same and Dissimilar Aluminum Alloys, *Journal of Materials Engineering and Performance, ASM International*, 11 (2002), 1, pp. 51-63
- [28] Milčić, D., et al., Temperature Based Validation of the Analytical Model for the Estimation of the Amount of Heat Generated during Friction Stir Welding, *Thermal Science*, 16 (2012), Suppl. 2, pp. 337-350