

EUROPEAN ORGANIZATION FOR NUCLEAR RESEARCH  
European Laboratory for Particle Physics



*Large Hadron Collider Project*

**LHC Project Report 629**

**LARGE CRYOGENIC HELIUM REFRIGERATION SYSTEM FOR THE LHC**

Ph. Lebrun

**Abstract**

In the framework of the Large Hadron Collider (LHC) project, CERN is presently building a large distributed cryogenic system to operate the high-field superconducting magnets of the 26.7 km accelerator in superfluid helium at 1.9 K. Refrigeration will be produced at several temperature levels down to 1.8 K, by eight cryogenic plants with a capacity of 18 kW @ 4.5 K (four of which recovered from the former LEP collider and suitably upgraded), feeding eight 2.4 kW @ 1.8 K refrigeration units using several stages of cold hydrodynamic compressors. After recalling the basics of LHC cryogenics, this paper gives an overview of the refrigeration system, from specification to design and production in industry, as well as status of the project.

AT Division

Invited paper at the Third International Conference on Cryogenics & Refrigeration (ICCR'2003)  
22-25 April 2003, Hangzhou, China

CERN  
CH - 1211 Geneva 23  
Switzerland

Geneva, 14 February 2003

# Large Cryogenic Helium Refrigeration System for the LHC

Ph. Lebrun

CERN, European Organization for Nuclear Research, CH-1211 Geneva 23, Switzerland

## ABSTRACT

In the framework of the Large Hadron Collider (LHC) project, CERN is presently building a large distributed cryogenic system to operate the high-field superconducting magnets of the 26.7 km accelerator in superfluid helium at 1.9 K. Refrigeration will be produced at several temperature levels down to 1.8 K, by eight cryogenic plants with a capacity of 18 kW @ 4.5 K (four of which recovered from the former LEP collider and suitably upgraded), feeding eight 2.4 kW @ 1.8 K refrigeration units using several stages of cold hydrodynamic compressors. After recalling the basics of LHC cryogenics, this paper gives an overview of the refrigeration system, from specification to design and production in industry, as well as status of the project.

## INTRODUCTION

The Large Hadron Collider (LHC), presently under construction at CERN near Geneva, Switzerland, is a unique high-energy, high-luminosity particle collider which will constitute – upon its completion and commissioning in 2007 - the most advanced research tool of the world's high-energy physics community<sup>[1]</sup>. In order to investigate the structure of matter and the forces at work among its basic constituents at a scale one thousand times smaller than the atomic nucleus, it will accelerate and bring into collision intense beams of protons and ions at center-of-mass energies of 14 TeV per unit charge. Four large experiments, installed around the collision points, will measure the emerging debris, reconstruct the particle interactions and look for new rare processes in the middle of well-known physics, at the border of the Standard Model and beyond it<sup>[2]</sup>.

Table 1 Main technical parameters of the LHC (proton beams) impacting on the cryogenic system

Circumference	26.7	km
Beam energy	7	TeV
Bending field	8.3	T
Luminosity	$10^{34}$	$\text{cm}^{-2} \cdot \text{s}^{-1}$
Beam intensity	0.56	A
Beam stored energy	350	MJ
Radiated power per beam	3.8	kW
Critical radiated photon energy	44.1	eV
Operating temperature	1.9	K
Cold mass	$36 \times 10^6$	kg
Helium inventory	$96 \times 10^3$	kg

To be cost effective, the LHC will reuse the tunnel, civil engineering and cryogenic infrastructure of the previous LEP collider, operated at CERN between 1989 and 2000 and now dismantled. Although they will follow the same path along the 26.7 km circumference tunnel, the proton beams of the LHC will be 70 times more energetic than the electron and positron beams of LEP, thus requiring the use of some 1800 high-field superconducting magnets for their guidance and focusing <sup>[3]</sup>. The nominal bending field around the LHC circumference is 8.3 T, obtained with 1200 tons of Nb-Ti conductor operated at 1.9 K in pressurized superfluid helium <sup>[4]</sup>. The main parameters of the LHC, and particularly those impacting on the cryogenic system, are listed in Table 1. From the cryogenic point of view, the LHC is thus a large distributed helium system operating at a variety of temperature levels down to 1.8 K, the main building blocks of which are described in reference <sup>[5]</sup>. In line with the subject of the conference, this paper focuses on the refrigeration system proper.

## FUNCTIONS, CONSTRAINTS AND ARCHITECTURE

The LHC will be installed deep underground in a quasi-circular tunnel, composed of eight 3.3-km long sectors with access shafts to technical service areas at ground level only at the ends of each sector. As a result, the cryogenic layout of the machine (Figure 1) features five cryogenic “islands” concentrating all refrigeration and ancillary equipment, both at ground level (electrical substation, compressor hall, cryogen storage, cooling towers, 4.5 K coldboxes) and underground (lower coldboxes, 1.8 K refrigeration units, interconnecting lines, distribution valve boxes). Each cryogenic “island” therefore feeds one or two adjacent sectors, via a compound cryogenic distribution line <sup>[6]</sup> distributing and recovering the cooling fluids over a distance of 3.3 km. The layout of the main components at such an “island” is sketched in Figure 2. Besides limiting geographical dispersion and grouping sensitive components, e.g. noisy compressors in sound-proofed machine halls, this layout provides modularity in installation, commissioning and operation of equipment, as well as redundancy for all sectors but one, while permitting the cryogenic plant at Point 1 to be used first for magnet tests and later for cooling of the ring.

The LHC cryogenic system is basically required to

- maintain the pressurized superfluid helium bath of all magnets around the ring at their nominal temperature below 1.9 K,
- cool down from ambient temperature and fill (respectively, empty and warm up to ambient temperature) each sector of the machine (with a mass of 4500 tons) in less than two weeks,
- accommodate resistive transitions of full cells (107 m) of the machine lattice and recover from these transitions in less than two hours, while minimizing loss of cryogen and system perturbations.

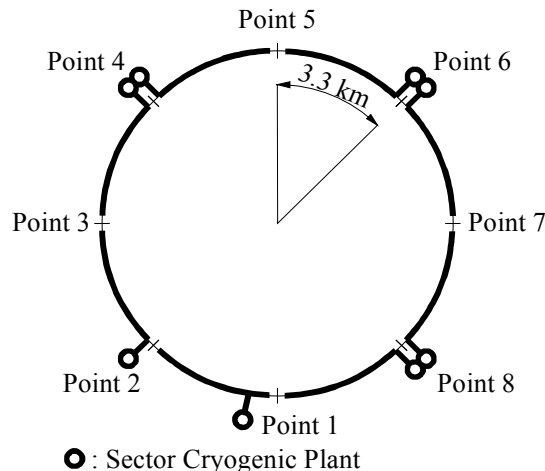

Figure 1 Overall layout of LHC cryogenic system

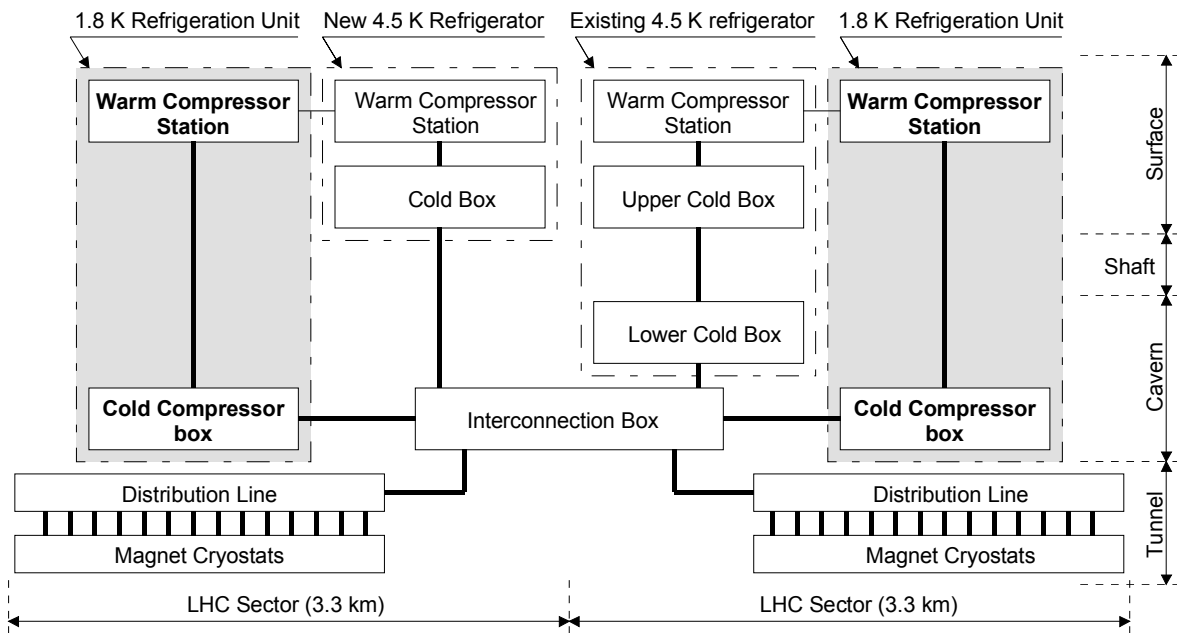

Figure 2 Cryogenic architecture at typical even point of LHC

The deep underground location of the LHC, in a long tunnel with a slope of 1.4% with respect to horizontal and limited access, also sets constraints on the type and form of cryogenics in use. All long-distance flows, undergoing large differences in elevation, must be single-phase to limit hydrostatic pressure buildup and avoid hydrodynamic instabilities. Moreover, the risk of oxygen deficiency in case of accidental release of cryogen precludes the use of liquid nitrogen, so that only helium is used underground.

## OPERATING MODES AND REFRIGERATION DEMANDS

The staging of temperature levels in the LHC cryogenic system generates the following loads:

- thermal shielding between 50 K and 75 K as primary heat intercept in all cryostats and transfer lines,
- non-isothermal cooling of the beam screens by supercritical helium between 4.6 K and 20 K, to absorb beam-induced loads (synchrotron radiation, beam image currents, electron “cloud”) before they reach the 1.9 K level,
- quasi-isothermal cooling of the magnet cold mass in superfluid helium below 1.9 K,
- isothermal cooling of stand-alone magnets, acceleration cavities and the lower section of HTS current leads in saturated helium at 4.7 K,
- non-isothermal cooling of the resistive upper section of current leads by forced flow of gaseous helium between 20 K and 290 K.

Most of these loads exhibit static and dynamic components. While the former are produced by heat inleaks and therefore depend on thermal insulation, the latter – both steady-state and transient - result from the powering of the magnets and the circulation of high-energy, high-intensity beams<sup>[7]</sup>. As an example, the heat load on the 1.9 K level will increase in the ratio 3:1 over a period of half an hour, upon current ramping of the magnets and beam acceleration to 7 TeV. Although partially buffered by the heat capacity of the superfluid helium bath, such a variation in demand requires load adaptation of the refrigerators over a large dynamic range. Taking into account these loads, and applying factors for uncertainty of 1.25 on static loads and 1.5 overall, yields the specified installed refrigeration capacity in the LHC sectors (Table 2).

Table 2 Installed refrigeration capacity in the LHC sectors

Temperature	50-75 K	4.6-20 K	4.7 K	1.9 K	3-4 K	20-280 K
	[W]	[W]	[W]	[W]	[W]	[g/s]
High-load sector	33000	7700	300	2400	430	41
Low-load sector	31000	7600	150	2100	380	27

#### 4.5 K REFRIGERATION PLANTS

Reusing the four LEP refrigerators, with split-coldbox design, sets the interface temperatures for the new LHC refrigeration plants at 4.5 K, 20 K, 50 K and 75 K. Since no high-density 4.5 K helium vapor returns from the ring, the coldboxes of the new 4.5 K refrigerators are installed at ground surface, thus saving precious space in underground caverns. The new refrigerators are tailored to the demands of the high-load sectors, while the less demanding low-load sectors will be fed by the upgraded LEP refrigerators. Most of the exergetic duty consists in supplying 4.5 K helium to the 1.8 K units, later returned at 20 K: the cold end of the plant therefore operates rather as a liquefier than as an isothermal refrigerator. The refrigeration power necessary to cool down the 4500 tons of each sector is formidable and can only be produced by liquid nitrogen. Consequently, each refrigerator will be equipped with a 600 kW liquid nitrogen precooler, used only during cooldown and liquid helium fill of the corresponding sector.

Following previous experience with large cryogenic helium plants delivered by European industry as turnkey projects, CERN issued in 1997 a functional and interface specification for the four new LHC refrigerators [8]. The adjudication rule took into account, besides capital investment, the integrated costs of operation over ten years, thus giving a premium to efficiency and – indirectly - compactness [9]. Procurement contracts for two refrigerators each have been placed with Air Liquide [10] and Linde Kryotechnik [11] in 1998. Both type of machines are based on modified Claude cycles with three pressure levels, featuring several parallel Brayton branches equipped with up to 10 expansion turbines in total, in order to compensate for the applied heat loads and resulting enthalpy unbalance at the adequate temperature levels. The quoted C.O.P. is about 230 W/W at nominal, and any deviation measured upon commissioning will impact on the final price through a bonus/malus system. Efficient load adaptation is performed by adjusting the high and medium pressures and hence the process flow and compressor power.



Figure 3 Compressor station of 18 kW @ 4.5 K cryogenic refrigerator



(a)



(b)

Figure 4 Coldboxes of 18 kW @ 4.5 K cryogenic refrigerators by Air Liquide (a) and Linde (b)

At CERN's request, and given the fact that both cycles make use of similar pressure levels and process flow-rate (about 1.6 kg/s), both manufacturers decided on the same compressor station based on Aerzen screw compressors, with a power input of some 4 MW (Figure 3). The first stage uses two 536 M and one 536 H machines in parallel, the second stage two 536 H machines in parallel. Each stage is followed by bulk oil separation and water-cooling. Final oil removal is achieved by three coalescing filters in series (for aerosols) and an activated charcoal adsorber (for vapors). The coldboxes integrate expansion turbines, piping, valves and aluminum plate-fin heat exchangers. These are mounted vertically in the Air Liquide design, giving rise to the L-shaped arrangement, while Linde Kryotechnik mounts them horizontally down to 20 K, thus permitting the simpler cylinder shape, easier to transport, handle and assemble on site (Figure 4).

## 1.8 K REFRIGERATION UNITS

Each 2.4 kW @ 1.8 K refrigeration units is connected to a 18 kW @ 4.5 K refrigerator through two interfaces: a supply of supercritical helium at 0.3 MPa, 4.6 K and a return of gaseous helium at 0.13 MPa, 20 K. These interfaces define the maximum exergetic load which the 1.8 K unit can apply to the 4.5 K refrigerator, seen as a non-isothermal cooling duty between 4.5 K and 20 K. Cycle optimization studies<sup>[12, 13]</sup> and prototype work on cold compressors<sup>[14]</sup> conducted at CERN and CEA Grenoble have shown that integral cold compression with direct return to the low-pressure side of the 4.5 K refrigerator is not possible, thus favoring a "mixed" compression scheme with active refrigeration by means of expansion turbines. The "mixed" compression scheme also has the advantage of bringing (warm) volumetric machines in the compression chain, thus making load adaptation easier. The eight 1.8 K refrigeration units were specified to industry along these lines<sup>[15]</sup>, with the additional requirements of

- turndown capability by a factor 3 to cope with the dynamic range of the LHC heat loads,
- cold compressors with proven technology for helium and MTBM of at least 8000 hours,
- warm compressors of the screw or liquid-ring type referenced for helium operation,
- mandatory helium guards for all subatmospheric piping and components which are not in a vacuum enclosure.

As for the 4.5 K refrigerators, the adjudication rule took into account the integrated costs of operation over a mix of capacity levels during ten years, thus acknowledging efficiency throughout the dynamic range of the machines. The quoted efficiency will be measured upon commissioning and give rise to a price bonus/malus.



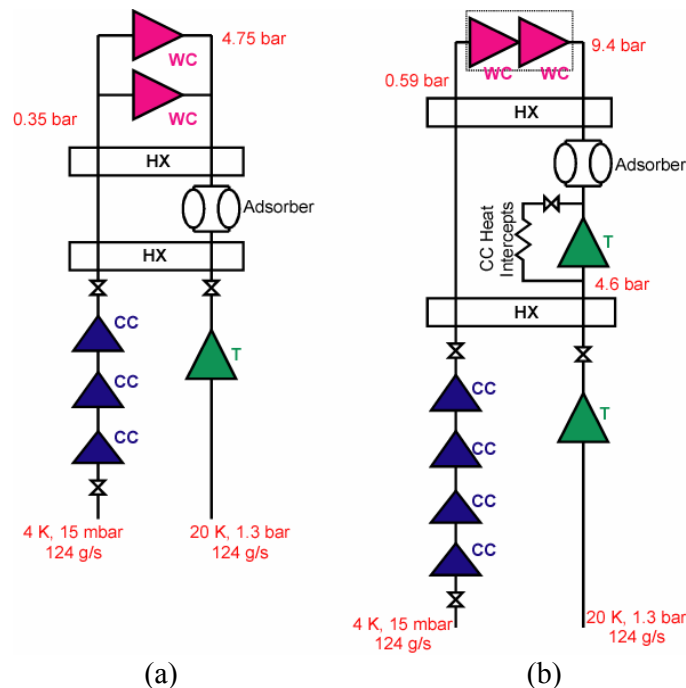

Figure 5 Process diagrams of 2.4 kW @ 1.8 K refrigeration units by Air Liquide (a) and IHI/Linde (b)

Two contracts for the supply of one preseries and three series 1.8 K refrigeration units each, were placed in 1999 with Air Liquide<sup>[16]</sup> and a consortium of IHI and Linde Kryotechnik<sup>[17]</sup>. Although similar in principle, the two cycles (Figure 5) exhibit several differences:

- the separation pressure between cold and warm compression at design flow-rate is 35 kPa for Air Liquide and 59 kPa for IHI/Linde, using respectively 3 and 4 stages of cold compressors,
- the Air Liquide cycle uses one expansion turbine and therefore needs only a moderate high pressure of 0.48 MPa, achievable with a one-stage warm compression, while the two turbines of the IHI/Linde cycle require a high pressure of 0.94 MPa, obtained with two-stage compression.

The cold compressors from both manufacturers use axial-centrifugal impellers, mounted on an exchangeable cartridge (Figure 6) integrating active magnetic bearings, high-speed electrical motor drive operating at room temperature and heat intercepts along the shaft. The isentropic efficiency of these machines reaches 75%. As for warm subatmospheric compressors, Air Liquide use two Kaeser screws in parallel, while IHI/Linde use a two-stage compound Mycom screw, with interstage pressure always kept above atmosphere. In both cases, the shaft seal is always on the discharge side, so as to see pressure above atmosphere and thus avoid contamination of the process helium.

## PROJECT STATUS AND PROSPECTS

All cryogenic plants described in this paper are being supplied by industry. The first two new 18 kW @ 4.5 K refrigerators have been commissioned by end 2002 and are now operational, while the other two are under installation and will be commissioned by end 2003. The upgrade of the four recovered 4.5 K refrigerators is scheduled to spread over 2004 and 2005. The first two preseries 2.4 kW @ 1.8 K refrigeration units have been successfully commissioned by end 2002, and will be used as test benches for series rotating machinery, before their final reinstallation. Production of the six series 1.8 K refrigeration units has begun in industry. All components of the cryogenic system at Point 8 will be ready for the first test of a complete 3.3 km sector mid-2005. It is planned to complete and cool down the eight sectors in steps by end 2006, for commissioning of the LHC with proton beams in 2007.



(a)



(b)

Figure 6 Cold compressors for 2.4 kW @ 1.8 K refrigeration units by Air Liquide (a) and IHI/Linde (b)

#### ACKNOWLEDGEMENTS

The work reported here is that of the Accelerator Cryogenics group at CERN, and I wish to thank L. Taviani and his colleagues for providing me with updated information and documentation on the project.

#### REFERENCES

- 1 The LHC Study Group, The Large Hadron Collider, Conceptual Design, CERN/AC/95-05 (1995)
- 2 Ph. Lebrun, Advanced superconducting technology for global science: the Large Hadron Collider at CERN, *Adv. Cryo. Eng.* (2002) 47 A, 3-14
- 3 C. Wyss, The LHC magnet programme: from accelerator physics requirements to production in industry, *Proc. EPAC'2000*, Austrian Academy of Science Press, Vienna, Austria (2000) 207-211
- 4 Ph. Lebrun, Superfluid helium cryogenics for the Large Hadron Collider Project at CERN, *Cryogenics* (1994) 34 ICEC Supplement 1-8
- 5 Ph. Lebrun, Cryogenics for the Large Hadron Collider, *IEEE Trans. Appl. Superconductivity* (2000) 10, 1500-1506
- 6 G. Riddone & R. Trant, The compound cryogenic distribution line for the LHC: status and prospects, paper presented at ICEC19, Grenoble, France (2002)
- 7 Ph. Lebrun, G. Riddone, L. Taviani & U. Wagner, Demands in refrigeration capacity for the Large Hadron Collider, *Proc. ICEC16*, Elsevier Science, Oxford, UK (1997) 95-98
- 8 S. Claudet, P. Gayet & U. Wagner, Specification of four new large 4.5 K refrigerators for the LHC, *Adv. Cryo. Eng.* (2000) 45 B, 1269-1276
- 9 S. Claudet, Ph. Gayet, Ph. Lebrun, L. Taviani & U. Wagner, Economics of large helium cryogenic systems: experience from recent projects at CERN, *Adv. Cryo. Eng.* (2000) 45 B, 1301-1308
- 10 P. Daguette, G.M. Gistau-Baguer & P. Briand, Two large 18 kW equivalent power at 4.5 K helium refrigerators for CERN's LHC project supplied by Air Liquide, *Adv. Cryo. Eng.* (2000) 45 B, 1277-1284
- 11 J. Bösel, B. Chromec & A. Meier, Two large 18 kW equivalent power at 4.5 K refrigerators for CERN's LHC project supplied by Linde Kryotechnik AG, *Adv. Cryo. Eng.* (2000) 45 B, 1285-1292



- 12 F. Millet, P. Roussel, L. Tavian & U. Wagner, A possible 1.8 K refrigeration cycle for the Large Hadron Collider, Adv. Cryo. Eng. (1998) 43 A, 387-393
- 13 S. Claudet, Ph. Lebrun & L. Tavian, Towards cost-to-performance optimization of large superfluid helium refrigeration systems, Proc. ICEC18, Narosa Publishing, New Delhi, India (2000) 203-206
- 14 A. Bézaguet, Ph. Lebrun & L. Tavian, Performance assessment of industrial prototype cryogenic helium compressors for the Large Hadron Collider, Proc. ICEC17, IoP, Bristol, UK (1998) 145-148
- 15 S. Claudet, P. Gayet, B. Jager, F. Millet, P. Roussel, L. Tavian & U. Wagner, Specification of eight 2400 W @ 1.8 K refrigeration units for the LHC, Proc. ICEC18, Narosa Publishing, New Delhi, India (2000) 207-210
- 16 B. Hilbert, G.M. Gistau-Baguer & F. Dagut, 2.4 kW at 1.8 K refrigeration units for the CERN LHC project: the Air Liquide system, Proc. ICEC18, Narosa Publishing, New Delhi, India (2000) 211-214
- 17 H. Asakura, J. Bösel, T. Honda, A. Kündig, K. Kurtcuoglu, A. Meier, M. Mori, A.E. Senn & S. Yoshinaga, Four 2400 W / 1.8 K refrigeration units for CERN-LHC: the IHI/Linde system, Proc. ICEC18, Narosa Publishing, New Delhi, India (2000) 215-218