

# High Voltage Power Supply Module Operating in Magnetic Field

M. Imori, H. Matsumoto, Y. Shikaze<sup>1</sup>, H. Fuke<sup>2</sup>, T. Taniguchi<sup>3</sup>, and S. Imada<sup>4</sup>

International Center for Elementary Particle Physics, University of Tokyo

7-3-1 Hongo, Bunkyo-ku, Tokyo 113, Japan

<sup>1</sup>Faculty of Science, Kobe University

Rokko-dai 1-1, Nada-ku, Kobe 657 Japan

<sup>2</sup>Faculty of Science, Department of Physics, University of Tokyo

7-3-1 Hongo, Bunkyo-ku, Tokyo 113, Japan

<sup>3</sup>National Laboratory for High Energy Physics (KEK)

1-1 Oho, Tsukuba-shi, Ibaraki-ken 305, Japan

<sup>4</sup>NF Corporation

6-3-20 Tsunashima Higashi, Kouhoku-ku, Yokohama 223, Japan

## Abstract

The article describes a high voltage power supply module incorporating a ceramic transformer. The high voltage power supply module incorporates a ceramic transformer which utilizes piezoelectric effect to generate high voltage. The ceramic transformer is constructed from a ceramic bar and does not include any magnetic material. The module can work without a loss of efficiency under a magnetic field of 1.5 tesla. The module includes feedback to stabilize the high voltage output, supplying from 3000 V to 4000 V with a load of more than 10 M $\Omega$  at efficiency higher than 60 percent. A supply voltage of 5 V is high enough to provide the high voltage from 3000 V to 4000 V at a load of more than 10 M $\Omega$ . The module will be soon commercially available from a Japanese company.

The module is provided with interface for a Neuron chip, a programming device processing a variety of input and output capabilities. The chip can also communicate with other Neuron chips over a twisted-pair cable, which allows establishing a high voltage control network consisting of a number of the modules which are interfaced by the Neuron chips individually. The functions of the module kept under the control of the chip are managed through the network. The chip turns on and off the module and sets the output high voltage. The chip detects the short circuit of the output high voltage and controls its recovery. The chip also monitors the output current. Thus the modules are monitored and controlled through the network.

## I. HIGH VOLTAGE POWER SUPPLY MODULE

The high voltage power supply module includes feedback to stabilize the high voltage output, supplying from 3000 V to 4000 V with a load of more than 10 M $\Omega$  at efficiency higher than 60 percent under a magnetic field of 1.5 tesla [1]-[4]. A Japanese company<sup>1</sup>, trying to improve the performance and to reduce the size of the module, will soon makes a compact high voltage power supply module commercially available. The module incorporates a ceramic transformer. The ceramic transformer takes the place of the conventional magnetic transformer. The ceramic transformer utilizes piezoelectric effect to generate high voltage. The ceramic transformer is

constructed from a ceramic bar and does not include any magnetic material. So the transformer is free of leakage of magnetic flux and can be operated efficiently under a magnetic field. The transformer is shaped symmetrically in the lengthwise direction and operated in the longitudinal vibration mode. The maximum power rating of the ceramic transformer is about 4 W.

In a high voltage control network, each module is interfaced by a Neuron chip<sup>2</sup>. Neuron chips enable the high voltage power supply modules to network intelligently. Neuron chips have all the built-in communications and control functions to implement LonWorks<sup>3</sup> nodes. These nodes may be easily integrated into highly-reliable distributed intelligent control networks called LonWorks network. Most functions of the module is brought under the control of the Neuron chip. So function of the module kept under the control of the Neuron chip is managed through the network. The module is turned on and off through the network. The high voltage is set through the network. The output current is also monitored through the network. Short-circuiting the high voltage is detected by the Neuron chip and reported through the network. The Neuron chip is enabled to recover the high voltage from feedback breakdown, for example, caused by the short-circuiting.

## II. FEEDBACK

The high voltage power supply is composed of divider resistors, an error amplifier, a voltage controlled oscillator (VCO), a driver circuit, the ceramic transformer and a Cockcroft-Walton (CW) circuit (Fig. 1). The VCO generates a driving frequency for a sinusoidal voltage wave which drives the ceramic transformer. The VCO supplies the driving frequency to the driver circuit where the sinusoidal voltage wave is generated synchronized with the driving frequency. The sinusoidal voltage wave is amplified in voltage by the transformer and then supplied to a Cockcroft-Walton (CW) circuit where the sinusoidal wave is amplified further in voltage and rectified. A high voltage is produced at the output of the CW circuit.

<sup>1</sup>NF Corporation <http://www.nfcorp.co.jp>

<sup>2</sup>Neuron is a registered trademark of Echelon Corporation.

<sup>3</sup>LonWorks is a registered trademark of Echelon Corporation.

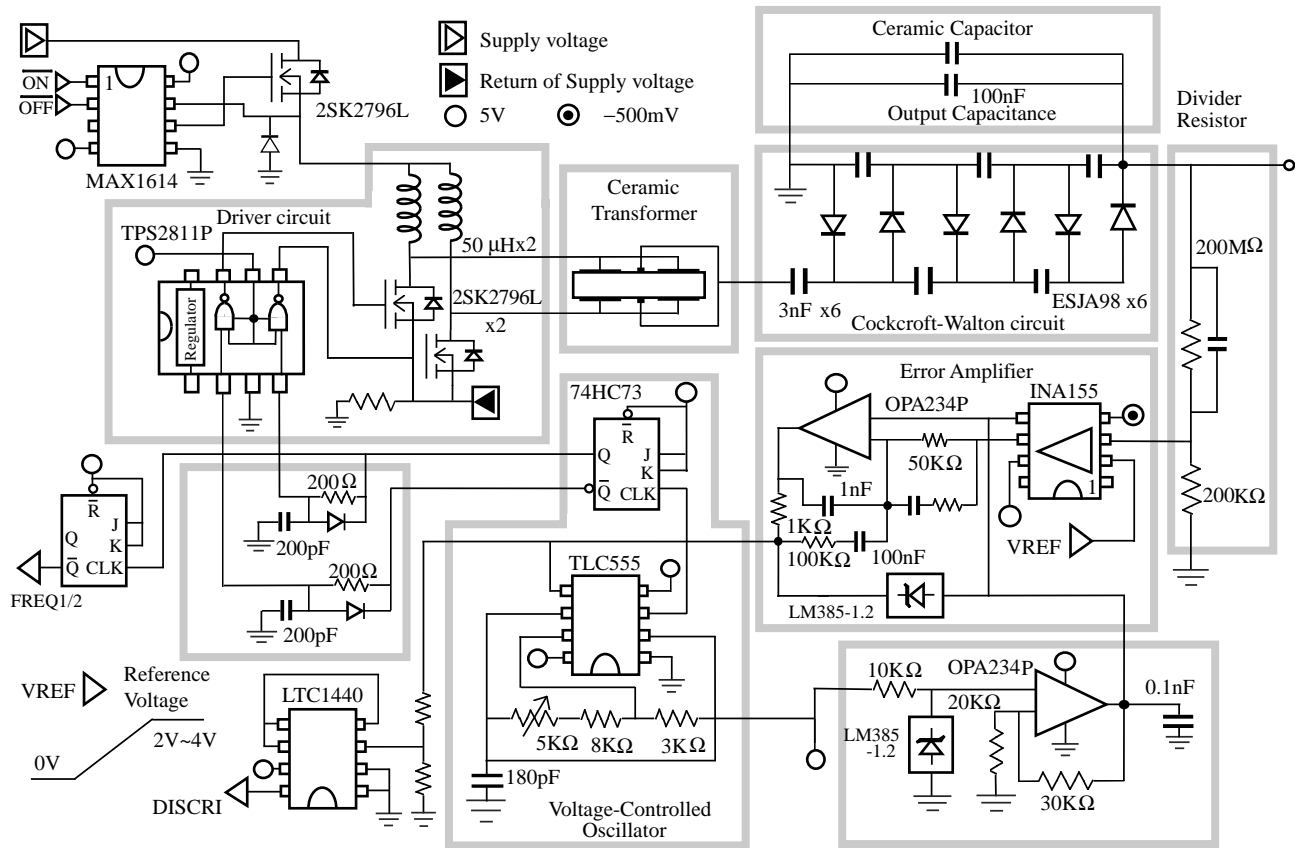

Figure 1: Schematic circuit of the high voltage supply module.

The voltage is divided by the divider resistors and fed to the error amplifier to be compared with a reference voltage. The output of the error amplifier is supplied to the VCO which generates the driving frequency. The sinusoidal voltage wave drives the transformer through the driver circuit. Voltage amplification of the transformer depends on the driving frequency. The driving frequency is a function of the output of the error amplifier. So the amplification is adjusted by controlling the driving frequency, which stabilizes the high voltage. Fig. 2 shows amplitude and phase of the transmission path from the output of the error amplifier to the output of the CW circuit.

The ceramic transformer includes an internal resonance circuit. The transformer input voltage is amplified at the output, with the input to output voltage ratio being an amplitude ratio that shows a resonance as a function of the driving frequency. The resonance is shown in Fig. 3, where the transformer is loaded with 100kΩ. The range of the driving frequency is designed to be higher than a resonance frequency of the ceramic transformer. As shown in Fig. 3, the feedback increases the driving frequency when the output voltage is higher than the reference voltage at the input of the error amplifier. Similarly, the driving frequency decreases when output voltage is lower than the voltage specified by the reference voltage.

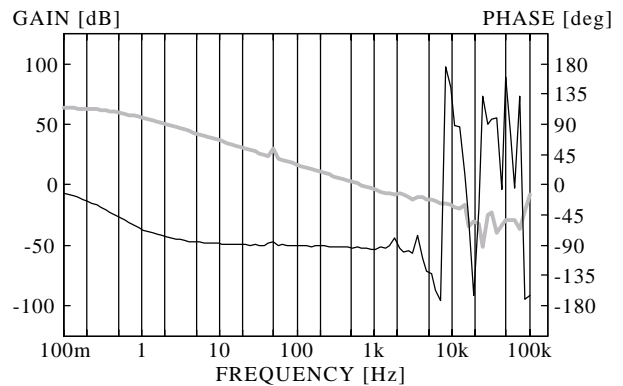

Figure 2: Amplitude and phase of the transmission path from the output of the error amplifier to the output of the CW circuit, where the output of the CW circuit is connected to a 6.25 MΩ load

### A. Breakdown of Feedback

When the power supply load falls within an allowable range, the driving frequency is maintained higher than the resonance frequency such that the feedback is negative, as designed. However, although the allowable range of load is sufficient for normal operation, it cannot cover, for example, a short circuit (output voltage to ground). When the load deviates

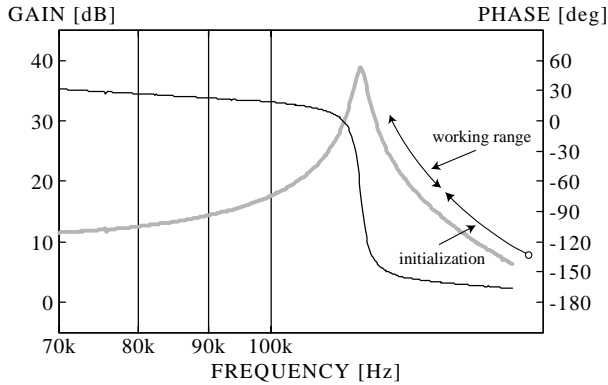

Figure 3: Resonance shown by the transformer loaded with 100k $\Omega$

from the allowable range, the driving frequency may decrease below the resonance frequency, resulting in positive feedback and effectively locking the circuit such that it is independent of load. In order to restore the negative feedback control, the driving frequency must be reset externally in addition to removing the load.

### 1) Circuit Protection

An abnormal load outside the allowable range causes the frequency of the VCO to decrease past the resonance frequency. The positive feedback, accompanied with the breakdown of feedback, reduces the frequency of the VCO to its lower limit. A frequency range of the VCO is adjusted so that the output voltage could be lowered enough at the lower limit in frequency. Thus the breakdown of feedback reduces the output voltage, providing circuit protection in the event of failures.

### B. VCO

The VCO is implemented by TLC555 and a flip-flop. The driving frequency is a function of the input voltage applied to its input terminal. The input voltage is limited between 2.3 V and 4.3 V. The driving frequency ranges from 80 kHz to 130 kHz. When the feedback breaks down, lowering the driving frequency below the resonance frequency of the transformer, the positive feedback raises the input voltage to an upper limit of 4.3 V, which reduces the driving frequency to 80 kHz. While the negative feedback works as designed, the input voltage remains relatively steady around 3 V, and does not exceed 4 V. Therefore feedback breakdown can be detected as an increase in the input voltage beyond 4 V.

### C. Interface with Neuron Chip

The Neuron chip detects the breakdown of the feedback at a DSCRI terminal in Fig. 1. The VCO outputs the driving frequency as a square wave. Thus the Neuron chip counts the pulses at a FREQ1/2 terminal in Fig 1. The driving frequency can be obtained by counting pulses over a fixed time interval.

## III. MEASUREMENT

Fig. 4 shows setup for measurement where the high voltage supply module is interfaced by the Neuron chip. The module, making a LonWorks node, is controlled by a computer. The output voltage is measured by a digital voltmeter connected to the computer, where the probe of the voltmeter steps the voltage down by a factor of 1000. Two voltage supplies provide electricity to the module; 6.5-V feed provides a 5-V line, and a variable voltage source supplies the driver circuit and set by the computer for measurement.

The node of the module includes a digital-to-analog converter which generates the reference voltage. The computer is set up to send a signal to the digital-to-analog converter and measure the corresponding driving frequency. The corresponding output voltage across the load resistance at the digital voltmeter is also monitored. In measurement, the output high voltage and the driving frequency are scanned automatically by incrementing the value sent to the converter. The output voltage was then plotted against the converter value revealing that the output voltage is linearly proportional to the converter value with negligible variance.

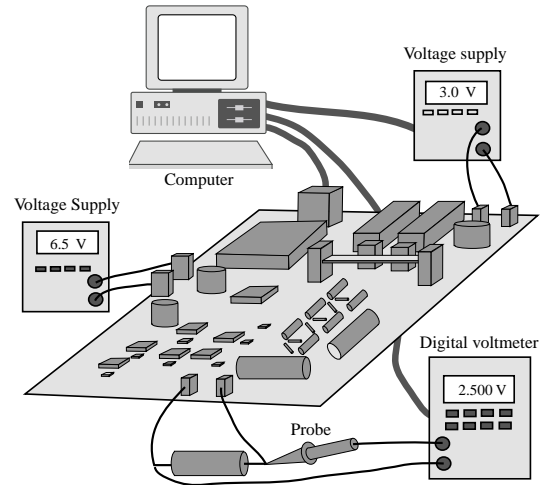

Figure 4: Setup for measurement

### A. Output High Voltage against Driving Frequency

Correspondence of the high voltage to the driving frequency may depend on the load resistance and the supply voltage to the driver circuit. The high voltage is plotted against the driving frequency for the various load resistances and the supply voltages, and Fig. 5 shows the plots for a load resistance of 21 M $\Omega$  with a supply voltage of 1 V to 3 V stepped in increments of 0.5 V. The high voltage is limited below 3.5 kV because of isolation breakdown.

It can be seen from the plot that the high voltage remains constant between 130 kHz and 124 kHz. The high voltage can not be lowered under the constant voltage. So the high voltage is clamped at the voltage while the high voltage is assigned to be lower than the constant voltage.

When the supply voltage is fixed, the high voltage becomes

maximum when the driving frequency is equal to the resonance frequency of the transformer. Attempting to increase the voltage further results in feedback breakdown.

For the transformer, the correspondence between the amplitude ratio and the driving frequency depends mainly on the load. While the load is fixed, the correspondence may be invariant to a first-order approximation. We therefore plotted the high voltage divided by a conversion factor (voltage ratio) against the driving frequency, as shown in Fig. 6, where the conversion factor is estimated to be the product of the supply voltage, the multiplier at the CW circuit of 5.5, and the ratio of amplitude of the carrier applied to the transformer to the supply voltage (3). Then, in rough approximation, the voltage ratio can be compared with the amplitude ratio of the transformer. It can be seen from the figure that the voltage ratio is linearly related to the supply voltage, which also holds for the amplitude ratio.

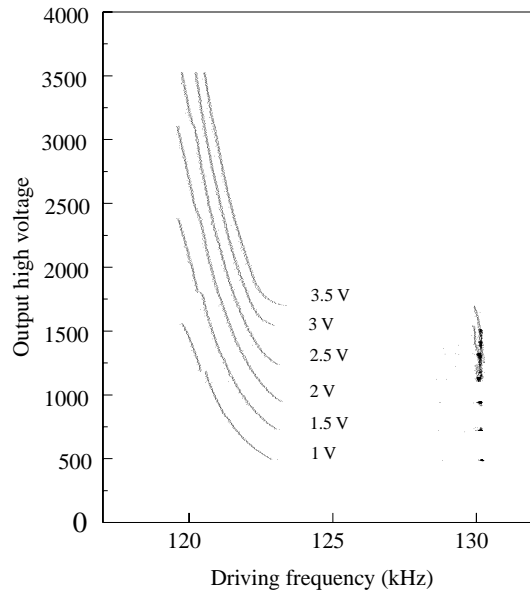

Figure 5: Output high voltage versus driving frequency for load resistance of  $21 M\Omega$  with the supply voltages from 1 V to 3.5 V by stepped at 0.5 V

### B. Load Resistance

The high voltage is plotted against the driving frequency for various loads, and Fig. 7 shows the plot for a load resistance of  $10 M\Omega$ . Fig. 8 shows the plot for a load resistance of  $4.7 M\Omega$ . It can be seen from the figures that the resonance frequency of the transformer shifts lower frequencies as the load becomes heavier.

## IV. NETWORK

### A. Neuron Chip

The Neuron chip is a system-on-a-chip with multiple microprocessors, read-write and read-only memory (RAM and ROM), a media-independent network communication port and a configurable I/O controller. The read-only memory contains

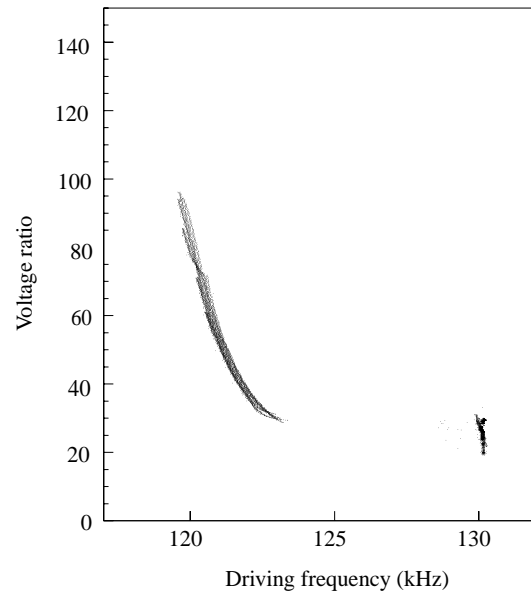

Figure 6: Voltage ratio plotted against driving frequency for a load of  $21 M\Omega$

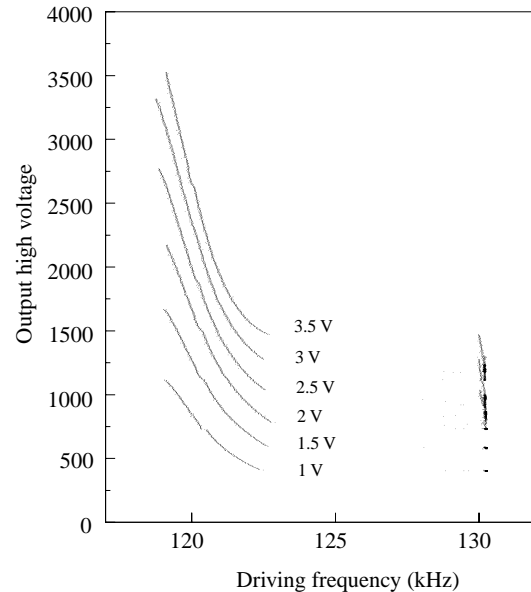

Figure 7: Output high voltage is plotted against the driving frequency for a load of  $10 M\Omega$  and various supply voltages.

an operating system, a LonTalk communication protocol, and an I/O function library. A complete implementation of the LonTalk protocol is contained in ROM in every Neuron chip. The chip has non-volatile RAM for configuration data and for the application program, both of which are downloaded over the network.

The I/O controller provides two timer/counters and configurable 11 I/O pins. Each Neuron chip contains three 8-bit CPUs. Two of the CPUs handle LonWorks protocol communication, and the third run an application. The Neuron chip can communicate with other Neuron chips

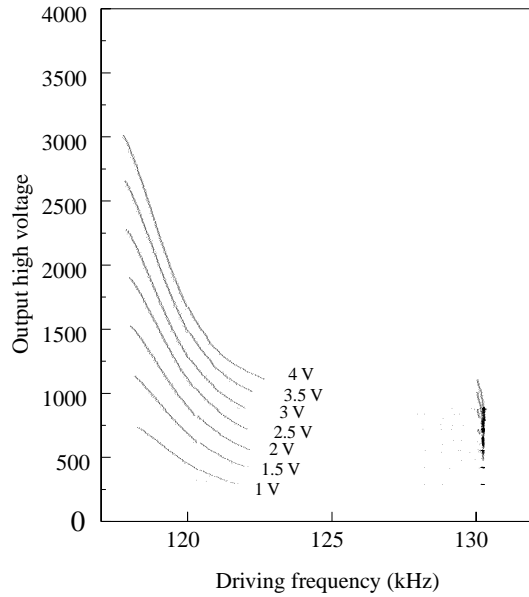

Figure 8: Output voltage versus driving frequency for a load of  $4.7 \text{ M}\Omega$  with various supply voltages

over a twisted-pair cable; a feature that allows establishing a network of the Neuron chip. The peer-to-peer protocol for communication allows all the Neuron chip connected to the network to communicate with each other.

### B. Node for Module

A LonWorks node for the high voltage power supply module includes the Neuron chip and integrates a communication transceiver, a clock, reset circuitry, and a 12-bit digital-to-analog converter. Most functions of the module being brought under the control of the Neuron chip, the modules are monitored and controlled through the network. Fig. 9 shows the interface with the module.

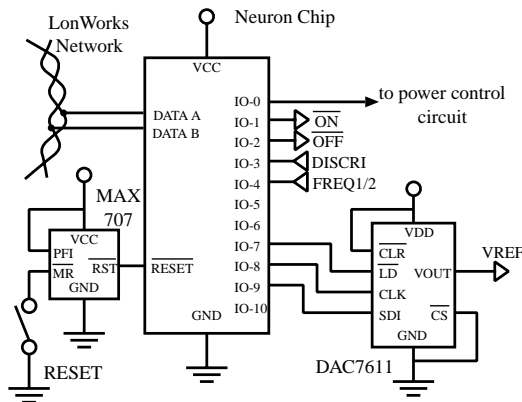

Figure 9: Interface circuit between chip and module

#### 1) Output High Voltage

The chip controls the 12-bit digital-to-analog converter which generates the reference voltage. The high voltage can be controlled using the converter via the network. The reference

voltage ranges from 0 V to 4 V, and 1/1000 of the high voltage, divided by the divider resistor, is compared with the reference voltage.

#### 2) Recovery from Feedback Breakdown

The Neuron chip detects the feedback breakdown and propagates the report through the network, assisting resolution of cause of the breakdown. The Neuron chip, following instructions received from the network, manages recovery from breakdown, where firstly the reference voltage is reset, which initializes the driving frequency, and secondly the chip increases the reference voltage to a prescribed value, restoring the high voltage.

#### 3) Current Monitor

It is assumed that the supply voltage to the driver circuit is fixed. Once the high voltage is assigned, the driving frequency at which the transformer is driven depends on the load. The driving frequency, obtained by counting pulses over a fixed time interval, allows the load to be calculated based on the shift of the driving frequency.

## V. ACKNOWLEDGMENTS

We are indebted to the people engaged in development of ceramic transformer at Material Development Center, NEC Corporation, for providing their newest ceramic transformers, and also indebted to Mr. Atsusi Ochi of NEC Corporation for continuous encouragement.

## VI. REFERENCES

- [1] Y. Shikaze, M. Imori, H. Fuke, H. Matsumoto, and T. Taniguchi, A High-Voltage Power Supply Operating under a Magnetic Field, IEEE Transactions on Nuclear Science, Volume: 48, June 2001 pp. 535 -540
- [2] M. Imori, T. Taniguchi, and H. Matsumoto, Performance of a Photomultiplier High Voltage Power Supply Incorporating a Piezoelectric Ceramic Transformer, IEEE Transactions on Nuclear Science, Volume: 47, Dec. 2000 pp. 2045 -2049
- [3] M. Imori, T. Taniguchi, and H. Matsumoto, A Photomultiplier High-Voltage Power Supply Incorporating a Ceramic Transformer Driven by Frequency Modulation, IEEE Transactions on Nuclear Science, Volume: 45, June 1998 pp. 777 -781
- [4] M. Imori, T. Taniguchi, H. Matsumoto, and T. Sakai, A Photomultiplier High Voltage Power Supply Incorporating a Piezoelectric Ceramic Transformer IEEE Transactions on Nuclear Science, Volume: 43, June 1996 pp. 1427 - 1431
- [5] S. Kawasima, O. Ohnishi, H. Hakamata et. al., Third Order Longitudinal Mode Piezoelectric Ceramic Transformer and Its Application to High-Voltage Power Inverter, IEEE Ultrasonic Sympo., Nov., 1994, Cannes, France. pp.525-530.
- [6] C. Y. Lin and F. C. Lee, Design of Piezoelectric Transformer Converters Using Single-ended Topologies, 1994 VPEC Seminar Proceedings, pp.107-112.