

ref: CERN/SPSC-2002-035  
SPSC-M-691  
3 November 2002

## Memorandum

# Status Report on Experiment NA48/2

The NA48/2 Collaboration

## 1 The goals

A high precision study of charged kaon decays has been proposed using a novel design for simultaneous  $K^+/K^-$  beams, and the NA48 set-up [1]. The main goal is to measure the CP-violating asymmetry in  $K^\pm \rightarrow \pi^+\pi^-\pi^\pm$  decays with an accuracy of  $\sim 10^{-4}$ . As a measure of direct CP violation an asymmetry

$$A_g = (g^+ - g^-)/(g^+ + g^-)$$

is considered, where  $g^+$  and  $g^-$  are the slope parameters describing, respectively, the linear dependence of the  $K^+$  and  $K^-$  decay probabilities on the energy of the odd pion in the kaon c.m. system.

The corresponding asymmetry  $A_g^0$  will be measured in  $K^\pm \rightarrow \pi^0\pi^0\pi^\pm$  decays at a similar precision level.

In addition more than  $10^6$   $K_{e4}$  decays will be reconstructed to obtain the  $\pi - \pi$  scattering length parameter  $a_0^0$  with an accuracy of better than  $1 \cdot 10^{-2}$ . This permits to measure the size of the  $q\bar{q}$  condensate of the QCD vacuum postulated in  $\chi PT$ .

The present knowledge of some charged kaon rare decays such as:

$$\begin{aligned} K^\pm &\rightarrow \pi^\pm \pi^0 \gamma, \\ K^\pm &\rightarrow \pi^\pm \pi^0 \gamma \gamma, \\ K^\pm &\rightarrow \pi^\pm \pi^0 l^+ l^-, \\ K^\pm &\rightarrow \pi^\pm l^+ l^-, \\ K^\pm &\rightarrow l^\pm \nu l^+ l^-, \end{aligned}$$

and others will be extended as well. This would allow  $\chi PT$  predictions at next-to-leading order to be tested.

The project NA48/2 [2] has been approved by the CERN Research Board on November 23rd, 2000. Data taking is scheduled for 2003.

## 2 Simultaneous $K^+/K^-$ beams

The K12 beam line will be rebuilt in such a way as to transport simultaneously positive and negative particles with momentum centered at 60 GeV/c to the NA48/2 detector in the underground hall ECN3 at the SPS. The charged particles will be produced in the existing target station T10 in TCC8 by 400 GeV/c primary protons - transported via the P42 beam line - at a nominal intensity of  $1 \cdot 10^{12}$ ppp (with 16.8s cycle time and 4.8s flat-top).

The momentum band selection for the two charges occurs via a "front-end achromat", consisting of 4 MTR-type magnets with deflections in the vertical plane. A system of four quadrupoles located just before a second achromat, renders the beams parallel. They each have an acceptance opening angle of  $\pm 0.36$  mrad in both planes and a momentum band of  $\pm 3.8\%$  (r.m.s.) (fig. 1).

The positive beam flux at the exit of the final collimator is expected to be  $5.4 \cdot 10^7$  particles per spill, the negative beam flux will be  $3.7 \cdot 10^7$  ppp. The corresponding fluxes of positive and negative muons from  $K$  and  $\pi$  decays in the 115 m decay volume are  $1.6 \cdot 10^6$  and  $1.1 \cdot 10^6$  per pulse, respectively.

Such beams provide an adequate number of charged kaons at an accept-

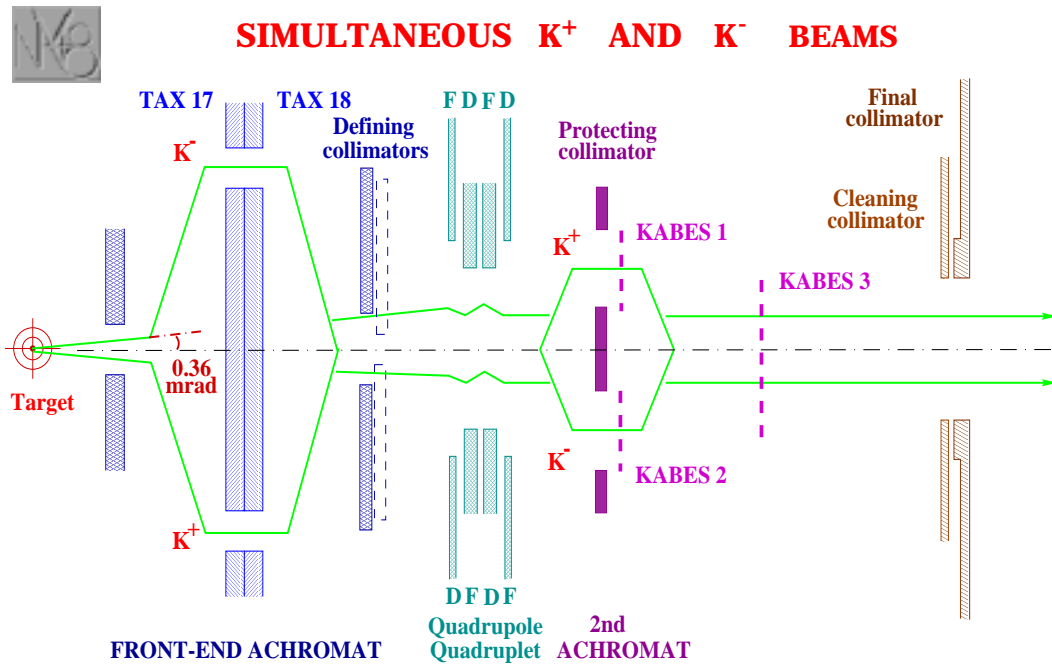

Figure 1: *The complete layout of the simultaneous  $K^+$  and  $K^-$  beams.*

able level of muon background. The choice of a very small divergence for the beam diminishes possible uncertainties in the reconstruction of various decay modes.

The resources needed for the beam construction have already been allocated by CERN. Construction is now in progress and is scheduled to be completed by Spring 2003.

### 3 The beam spectrometer

A beam spectrometer, KABES, has been proposed by the Saclay group to resolve the twofold ambiguity in the kinematical reconstruction of  $K_{e4}$  decays, to allow two pion events of  $K^\pm \rightarrow (3\pi)^\pm$  decays to be reconstructed (where one pion escapes detection), and to enhance the number of rare decays which could be investigated.

KABES is a TPC-type detector based on the MICROMEAS principle [4]. It includes three double stations, each measuring two coordinates (fig.2). Two stations (one per beam) will be located in the second achromat at the

## Micromegas Time Projection Chambers

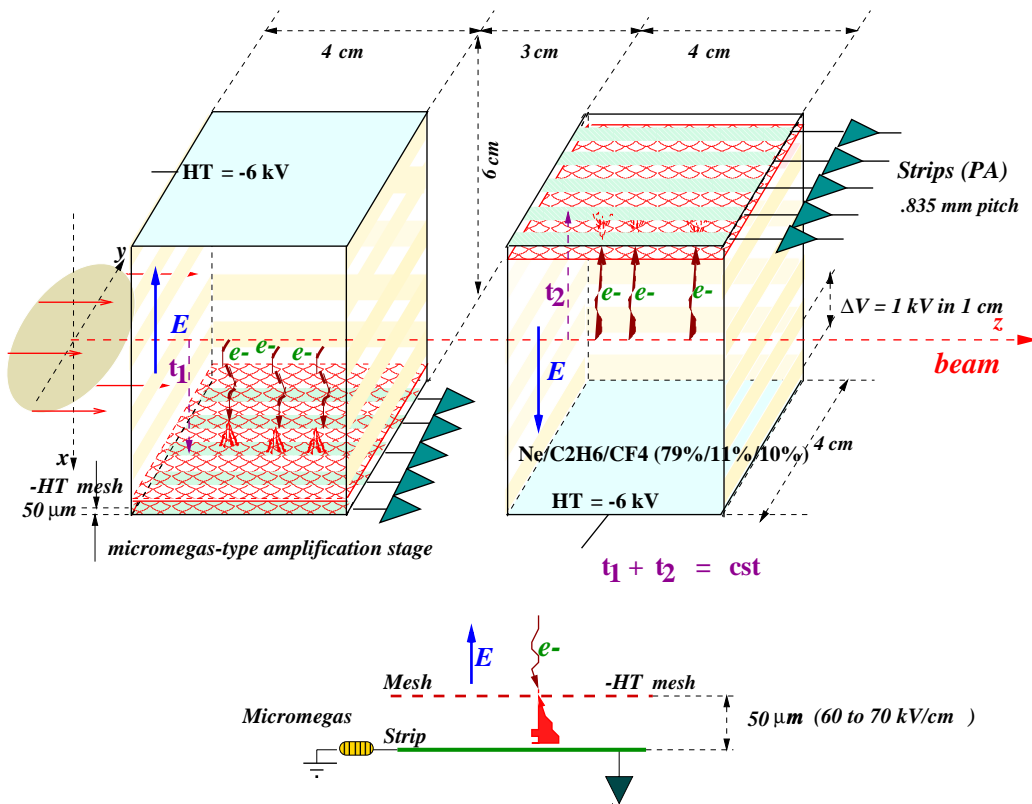

Figure 2: Principle of KABES double station working.

position where the beams are separated and parallel, while a third one will be installed in the beam line after the second achromat (fig.1). Such a configuration of KABES stations allows one to obtain the sign and the momentum of the individual beam particles from the difference between vertical coordinates measured by KABES-1/2 and KABES-3. The transverse position of a beam particle is measured by the KABES-3 station.

Several tests of various KABES prototypes with amplification gaps from  $50\mu\text{m}$  to  $100\mu\text{m}$  have been carried out successfully at CERN SPS in 2001 and 2002 (fig.3). The final prototype version with an amplification gap of  $50\mu\text{m}$  has been chosen .

The gas mixture identical to that used by COMPASS micromegas detector. i.e.  $Ne(79\%) + C_2H_6(11\%) + CF_4(10\%)$ , gives satisfactory performances for our application. The station with optimised parameters performed reliably up to  $6 \times 10^7$  hadrons per burst of 4.3s. The peak rate on the strips

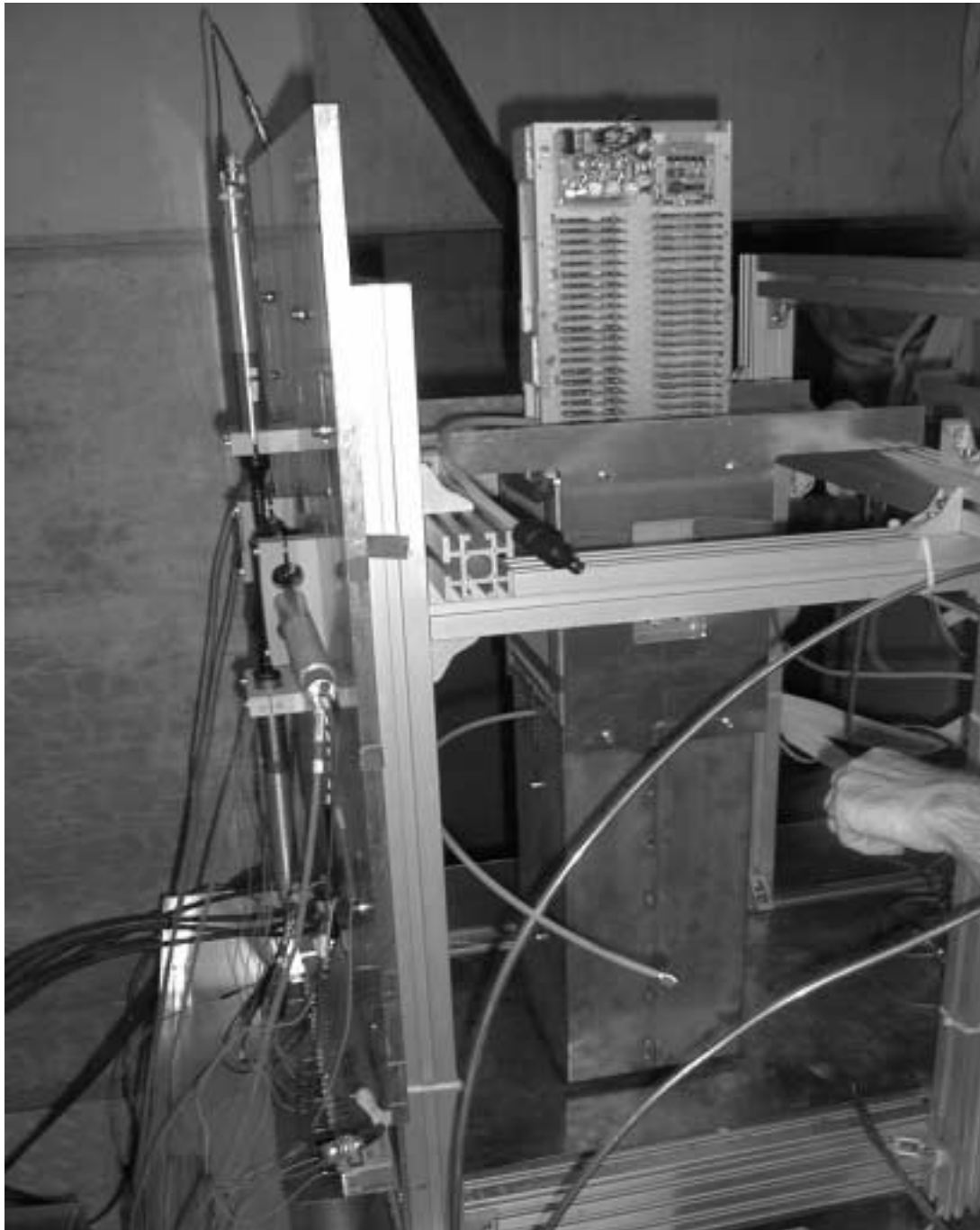

Figure 3: *The prototype of KABES 2 double station and tracker in the test beam at CERN SPS in July 2002.*

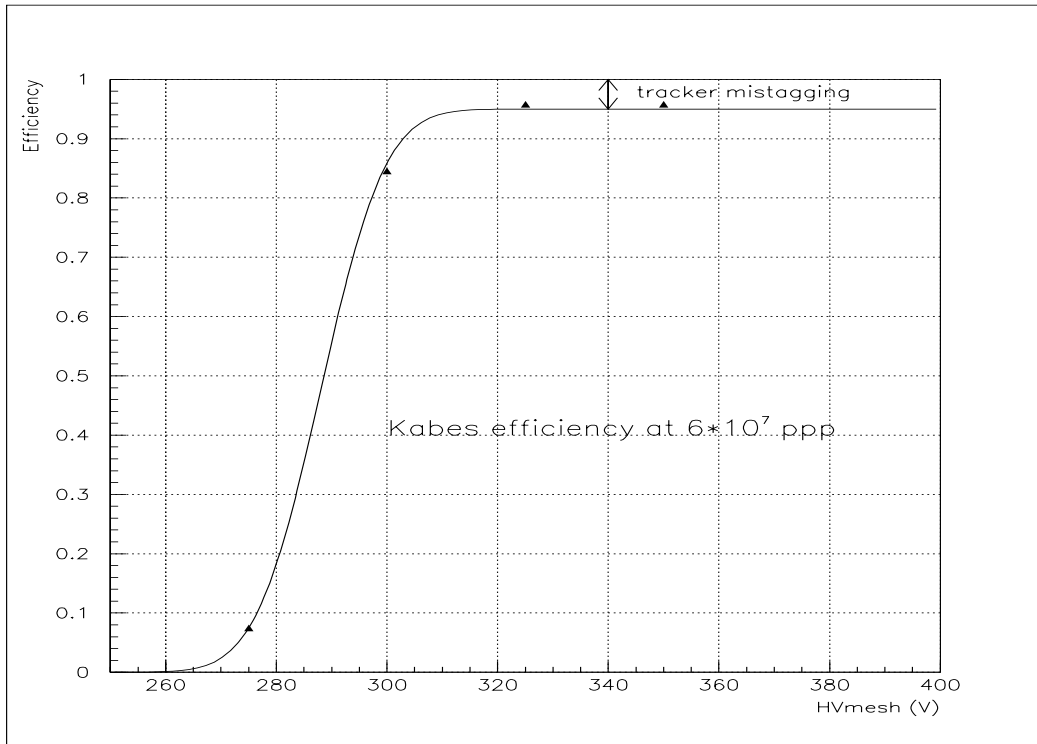

Figure 4: *The measured efficiencies of KABES stations.*

located in the center of the beam was measured to be  $\sim 2$  MHz. As expected, a mean cluster size of 2 strips has been measured. The efficiency was studied in detail at various HV settings and beam intensities. The charged particle rate was varied from  $0.7 \cdot 10^7$  to  $6.1 \cdot 10^7$  particles per burst. An efficiency  $> 94\%$  was obtained at the HV plateau of 350 V (fig.4).

A spatial resolution of  $\sim 50\mu m$  has been achieved in the drift direction (measurement of horizontal coordinate) and of  $\sim 90\mu m$  measured on the strips (fig.5). The time resolution, taking into account trigger jitter and other corrections, has been determined to be better than 1 ns (fig.6).

The spectrometer will therefore provide the required beam momentum resolution of better than 0.5%. It works reliably at high beam intensity, which especially critical for the third station where the beams overlap.

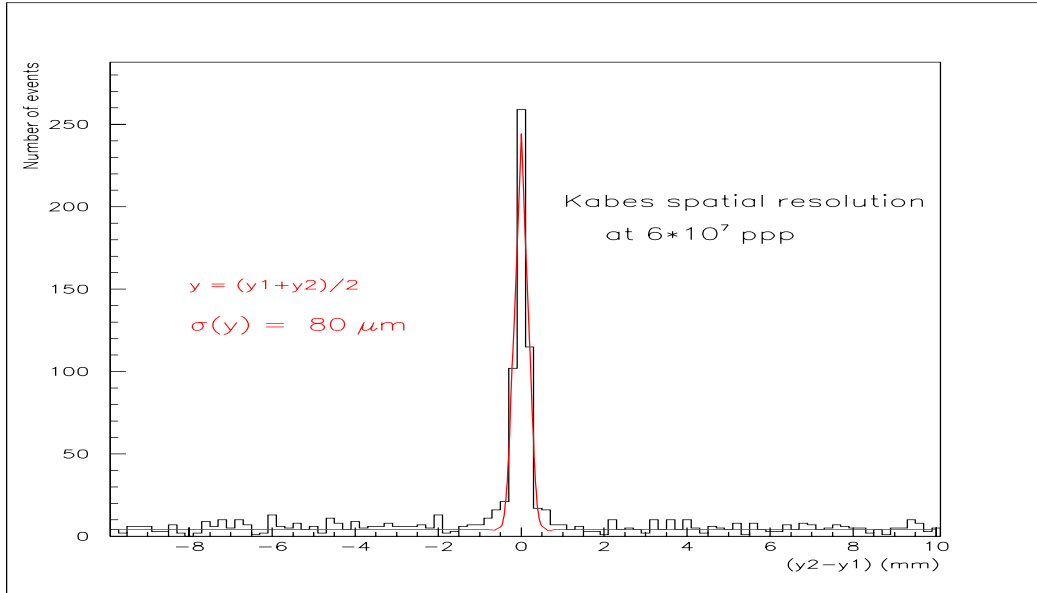

Figure 5: *The measured spatial resolution of KABES stations.*

## 4 KABES read-out

A read-out electronics architecture, based on the HPTDC (High Performance TDC) chip developed at CERN [3], has been proposed by the Saclay group [5] and further developed in Dubna. The KABES read-out system is aimed to work at an input rate up to 40 M particle/s with a maximum of 8 M hits/s on one strip, for a total rate of 960 MB/s per chamber. In total 288 TDC channels are required. The architecture of the system is presented in fig.7.

The system is designed in VME standard. A 6U VME64x crate houses the main components: an interface module (SLVME) and the 6 read-out cards (ROCs). To operate the system, a standard desk-top PC, equipped with S-link to PCI cards and optical S-link interface, will be used. The SLVME module, standard VME64x(3U), is designed to:

- master operate with 2eSTT transfer mode;
- interface the ROC's cards to the PC, using a high speed full duplex optical S-link (tested at 102 Mbyte/s forward channel, and 640 Kbit/s return channel);

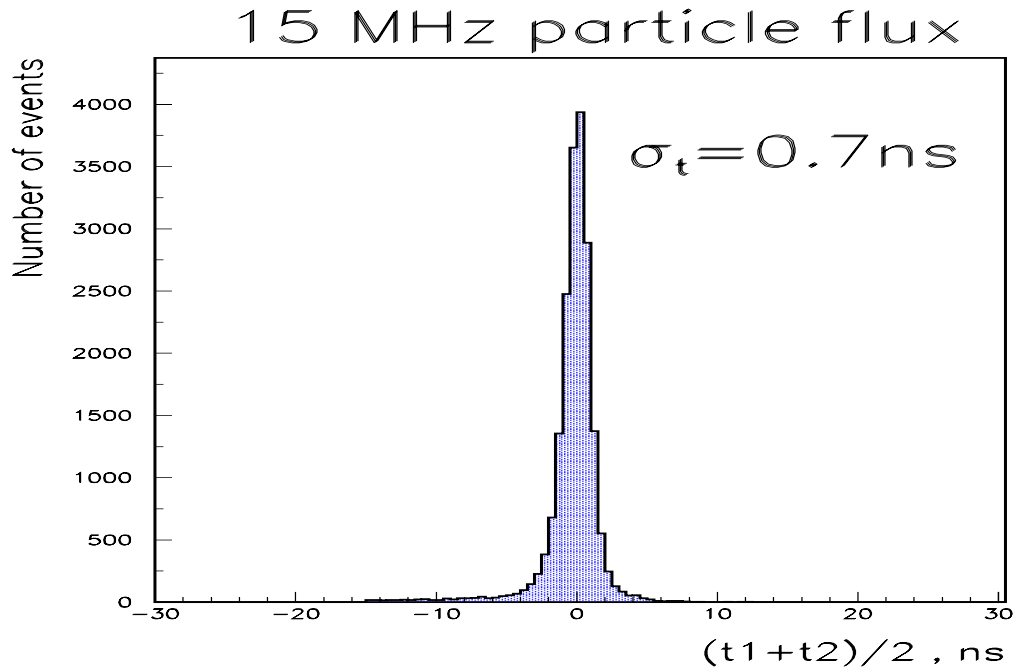

Figure 6: *The measured time resolution of KABES stations.*

- receive L1 trigger strobes through optical input and fan-out them to the ROC cards;
- receive L2 trigger words through optical TAXI receiver and fan-out them to the ROC cards;
- receive clocks, start/end of burst, control signals through ECL and LEMO connectors.

This module has been manufactured, tested and is ready for use (see fig.8).

The ROC module is the unit housing the HPTDC chips (6/module) and devoted to measure the KABES signal's time, buffer the informations and send them out according with triggers L1 and L2 request. The internal logic is realized by means of a XILINX XC2V2000 chip. The main functions are:

- slave operating mode;
- front-pannel connections to the KABES amplifiers;
- high speed connection to the PC.



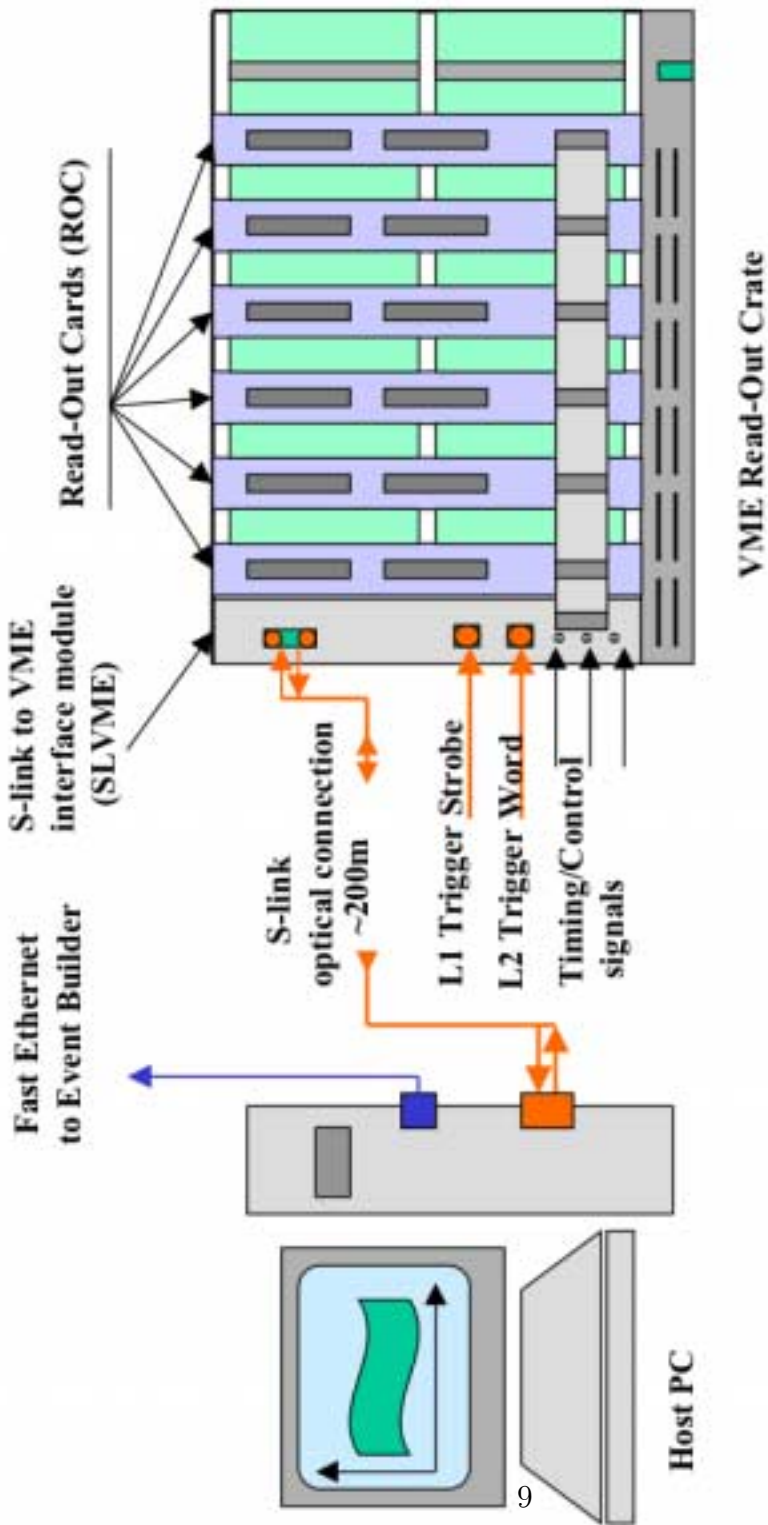

Figure 7: *KABES* read-out system architecture.



Figure 8: *SLVME* module.

Characteristics	Units
VME-bus transfer rate	160 MB/s
Number of TDC channels	48 x 2
Time measurement precision	300ps RMS
Max. hit rate per channel	8 Mhit/sec
Max. L1 latency	5.5 $\mu$ s
L1 FIFO depth	16
Max. event size per ROC	1 KB (256 x 32bit)
L2 Ring memory size /chamber	64 KB
Max. L2 trigger rate	25 KHz
Transmission TDC inputs standard	dECL

Table 1: ROC module main features.

The capabilities of the module are listed in table 1.

The HPTDC has been tested using a special evaluation board and KABES emulator, both designed and built in Dubna. The ROC prototype board is now under production at JINR. Complete testing of the read-out electronics prototype and its integration into the NA48 set-up is planned at CERN in November 2002.

## 5 Electron identification

A TRD detector was planned to be integrated with the NA48 detector to obtain additional rejection power for  $e/\pi$  separation and hence reduce the background for  $K_{e4}$  and other rare decays of charged kaons. The responsibility for the TRD was to have been taken by four US Institutions (University of Chicago, Illinois Institute of Technology, Northwestern University and University of Iowa).

Recently the Collaboration has been informed by a representative of the US groups that the DoE had not granted the required funding for modifications of the KTEV TRD to be used in the experiment NA48/2.

Independently, the Collaboration developed an alternative method of pro-

viding additional  $e/\pi$  separation, based on neural networks (NN-method [6]) better exploit all the information available from the Liquid Krypton Calorimeter (LKr). The NN-method uses additional input variables related to the transverse shower development in the LKr (like the shower width, the distance between the extrapolated from the drift chambers spectrometer impact point in LKr to the centre of corresponding shower, etc.). The method was implemented and tested on the data collected in a 2001 test run. The test run was carried out in a single charged kaon beam of alternating polarity and employed equipment and triggers similar to those envisaged for the 2003 run. However, the beam momentum distribution was broader than the design value for 2003, and the beam particle momentum was not measured by a beam spectrometer. To train the NN and test its capability,  $\sim 930000$  pions from reliably reconstructed  $K^\pm \rightarrow \pi^+\pi^-\pi^\pm$  and  $\sim 20000$  electrons from the  $\pi^0$  Dalitz decays ( $K^\pm \rightarrow \pi^\pm\pi_D^0 \rightarrow \pi^\pm e^+ e^- \gamma$ ) were selected. During the learning phase, 20000 pions and 10000 electrons from this sample were used. The NN performance was tested on the rest of the  $\pi$ 's and  $e$ 's. An additional  $\pi$  rejection factor of better 30 and 45 beyond that of the conventional ( $E/p > 0.9$ )  $e$ -identification was achieved. The corresponding  $e$  selection efficiency ranged from 96% to 93%.

The NN-method was implemented for the  $K_{e4}$  selection, as well. The  $K_{e4}$  decays were first reconstructed applying the conventional  $e$  selection cut combined with the relevant kinematical criteria. The distribution of selected  $K_{e4}$  candidates over the effective mass of the three charged particles in the  $3\pi$  hypothesis ( $M_{3\pi}$ ) is plotted in fig.9 (red distribution). As seen in this plot, there is a significant peak at the kaon mass indicating a large  $K \rightarrow 3\pi$  contamination in this sample of  $K_{e4}$  candidates. An additional requirement of NN identification of an  $e$  candidate with a probability of  $> 96\%$  leads to a significant reduction of this  $K \rightarrow 3\pi$  background (blue distribution in fig.9). In total,  $\sim 1500$   $K_{e4}$  events were reconstructed. The combination of conventional and NN methods leads to a  $\pi$  rejection factor of  $\sim 3600$  at a  $\sim 96\%$  efficiency of  $e$  selection. The estimated background due to  $e/\pi$  misidentification is at the level of  $\sim 1\%$ . The loss of  $K_{e4}$  events due to NN electron recognition efficiency is at the level of 5%. The distribution of  $3\pi$  invariant mass ( $M_{3\pi}$ ) obtained for the finally selected  $K_{e4}$  decays are in good agreement with that obtained for MC simulation. (stars distribution in fig.9).

In the 2003 run, the beam momentum spectrum is expected to be narrower ( $P_K = 60 \pm 2.2$  GeV/c) than that of the test run, and the kaon direction

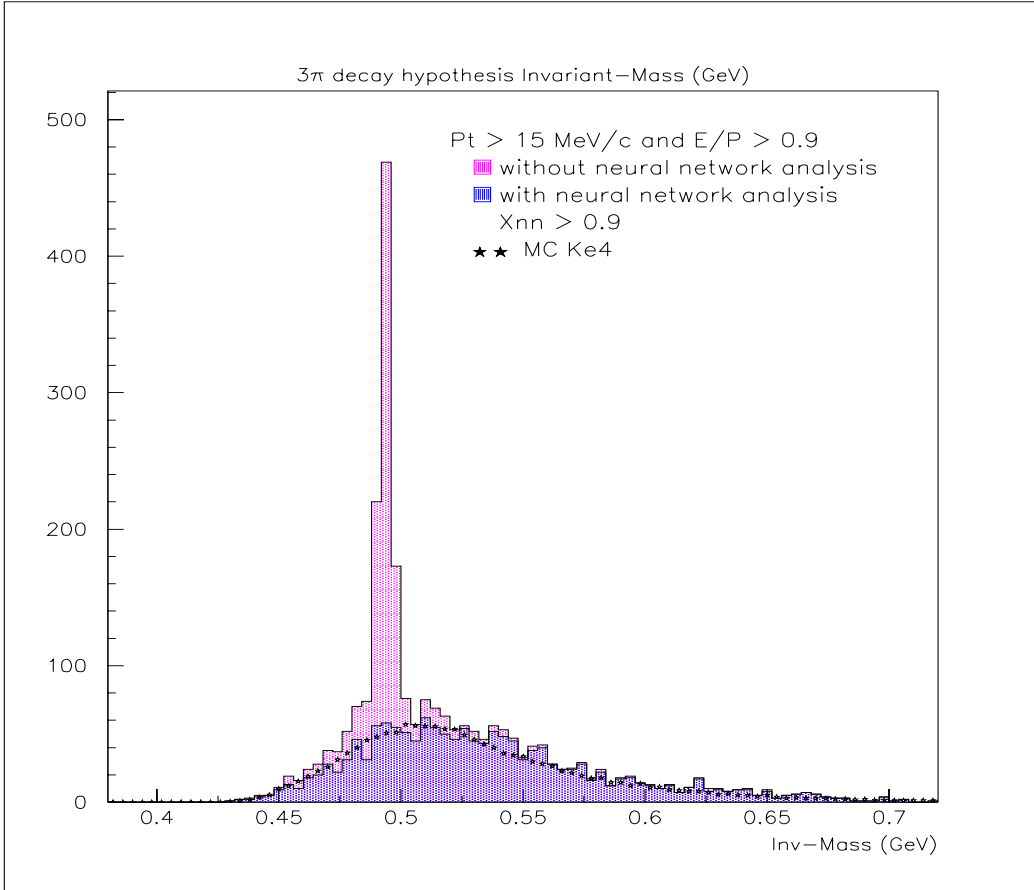

Figure 9: *The  $3\pi$  invariant mass distribution for  $K_{e4}$  candidates selected without and with NN-method implementation and its comparison with corresponding distribution of MC simulated events.*

will be known with an accuracy of  $\pm 0.02$  mrad. These factors should allow additional rejection for the background from  $K \rightarrow 3\pi$  decays. An analysis of MC simulated events indicates that applying kinematical constraints, coming from the KABES information, the  $K \rightarrow 3\pi$  background could be suppressed by an additional factor of two while losing only 3% of  $K_{e4}$  events.

The results obtained by implementing the NN-method are comparable to the rejection factor expected from a TRD configuration that could have been fit into a modified NA48/2 layout.

Given this NN performance as well as the resource savings for CERN and other simplifications in the preparation of the run (since a read-out system

for the TRD and mechanical modifications of NA48 layout are no longer needed), the Collaboration decided not to include the TRD in the NA48/2 configuration.

The TRD was anyway not intended for use in the search for direct CP violation in three pion decays of charged kaons, which remains the primary goal of the experiment.

## 6 Run in 2003

The proposal was based on the sensitivity that could be attained with 120 days of data-taking at  $1 \cdot 10^{12}$  400 GeV/c protons per pulse onto T10. It became clear now that only 16 weeks of proton running are scheduled at SPS in 2003, of which 1 week will be devoted to another run with 25ns r.f. bunched beam at reduced intensity. The remaining 15 weeks, after subtraction of M.D. time, amount to no more than 98 days.

To stand a reasonable chance of being able to set up the new beam together with the detector and to accumulate sufficient data to achieve the goals of the experiment in the year 2003, it is necessary that NA48/2 be scheduled to run for the full remaining time.

We request that the week with 25ns structure be scheduled at the beginning, as could be used for first tuning of the new K12 beam in conjunction with the detector. Any proposal to schedule the special 25ns run in the midst of the normal proton time would be disruptive and entail two set-up periods, leading to a further loss of effective running time for NA48/2.

## 7 Summary

The preparation of the experiment is proceeding according to schedule.

A preliminary analysis of the short 2001 test run [7] shows that the estimate of the statistical precision of the measured asymmetry  $A_g$  is in agreement with that indicated in the proposal. Further analysis of the data accumulated in this run has allowed the trigger criteria to be refined and the preparation for the real data taking to proceed efficiently.

## References

- [1] V. Fanti et al, Phys.Lett. B 465, 335 (1999).
- [2] J. R. Batley et al, CERN/SPSC 2000-003, (2000).
- [3] M. Mota et al. A Flexible Multi-Channel High Resolution Time to Digital Converter ASIC. Nuclear science symposium, Lyon, France, October 2000.
- [4] I. Giomataris et al., NIM, A376 (1996) 29.
- [5] I. Mandjavidze, B.Vallage, NA48 Note: 02-01 (2002).
- [6] L. Fausett. Fundamentals of Neural Networks: Architecture, Algorithms and Applications, Prentice-Hall, NJ, 1994.
- [7] V. Kekelidze, NA48/2 status report, SPSC/M671, CERN/SPSC 2001-030 (20 October, 2001).