

EUROPEAN ORGANIZATION FOR NUCLEAR RESEARCH

CERN/PS/2002-065 (PP)

RADIOACTIVE ION BEAMS PRODUCED BY NEUTRON-INDUCED FISSION AT ISOLDE*

R. Catherall**, J. Lettry, S. Gilardoni, U. Köster and the ISOLDE collaboration

Abstract

The production rates of neutron-rich fission products for the next-generation radioactive beam facility EURISOL are mainly limited by the maximum amount of power deposited by protons in the target. An alternative approach is to use neutron beams to induce fission in actinide targets. This has the advantage of reducing: the energy deposited by the proton beam in the target; contamination from neutron-deficient isobars that would be produced by spallation; and mechanical stress on the target. At ISOLDE CERN, tests have been made on standard ISOLDE actinide targets using fast neutron bunches produced by bombarding thick, high-Z metal converters with 1 and 1.4 GeV proton pulses.

This paper reviews the first applications of converters used at ISOLDE. It highlights the different geometries and the techniques used to compare fission yields produced by the proton beam directly on the target with neutron-induced fission. Results from the six targets already tested, namely UC₂/graphite and ThO₂ targets with tungsten and tantalum converters, are presented.

To gain further knowledge for the design of a dedicated target as required by the TARGISOL project, the results are compared to simulations, using the MARS code interfaced with MCNP libraries, of the neutron flux from the converters interacting with the actinide targets.

*Paper presented at the 14th International Conference on Electromagnetic Isotope Separators
and Techniques Related to their Application
Victoria, B.C. Canada, 6-10 May, 2002*

Geneva, Switzerland
12 September 2002

RADIOACTIVE ION BEAMS PRODUCED BY NEUTRON-INDUCED FISSION AT ISOLDE*

* Supported by the EU-RTD project TARGISOL (HPRI-CT-2001-50033).

** email: richard.catherall@cern.ch

* Supported by the EU-RTD project TARGISOL (HPRI-CT-2001-50033).

Abstract

The production rates of neutron-rich fission products for the next-generation radioactive beam facility EURISOL [1] are mainly limited by the maximum amount of power deposited by protons in the target. An alternative approach is to use neutron beams to induce fission in actinide targets. This has the advantage of reducing: the energy deposited by the proton beam in the target; contamination from neutron-deficient isobars that would be produced by spallation; and mechanical stress on the target. At ISOLDE CERN [2], tests have been made on standard ISOLDE actinide targets using fast neutron bunches produced by bombarding thick, high-Z metal converters with 1 and 1.4 GeV proton pulses.

This paper reviews the first applications of converters used at ISOLDE. It highlights the different geometries and the techniques used to compare fission yields produced by the proton beam directly on the target with neutron-induced fission. Results from the six targets already tested, namely UC₂/graphite and ThO₂ targets with tungsten and tantalum converters, are presented.

To gain further knowledge for the design of a dedicated target as required by the TARGISOL project [3], the results are compared to simulations, using the MARS [4-7] code interfaced with MCNP [8,9] libraries, of the neutron flux from the converters interacting with the actinide targets.

Introduction

As outlined in several scientific committees, such as NuPECC [10], there is a demand for higher intensities of neutron-rich fission products. For an ISOL-type Radioactive Nuclear Beam (RNB) facility, higher intensities may be achieved by increasing the current of the driver beam, but this has the disadvantage of increasing the beam power deposited in the target. An alternative approach is to use neutron beams to create fission in actinide targets. At ISOLDE CERN, tests have been made on standard actinide targets using fast-neutron bunches produced by bombarding thick, high-Z metal converters with 1 and 1.4 GeV protons. The primary beam power is deposited in the relatively cold converter thus reducing the thermal and mechanical stress on the actinide target. Furthermore, the reaction of converter spallation neutrons with the actinide target improves the ratio of neutron-rich isotopes to neutron deficient isobars normally produced by direct bombardment of the proton beam on the target.

Simulations using the MARS code interfaced with MCNP libraries are used to try and understand the neutron flux produced from different converters in an attempt to optimize both the geometry and converter material for a proposed cylindrical target design [11,12].

Description

Six actinide targets were tested at ISOLDE using either tantalum or tungsten converters of different length and diameter. By modifying existing ISOLDE target units and deflecting the proton beam between target and converter, it is possible to make a direct comparison of neutron-rich isotopes produced by either 1 or 1.4 GeV protons, or by secondary neutrons. The proton beam intensity varies between 1×10^{13} and 3×10^{13} protons per pulse with a pulse length of 2.4 μ s. A focused proton beam was used to bombard the converters with a proton beam size varying from 8 mm² for an intensity of 1×10^{13} and 13 mm² for an intensity of

^{**} email: richard.catherall@cern.ch

3×10^{13} protons per pulse [13]. Different ion sources [14] were used for converting nuclear reaction products into radioactive ions. The ions are accelerated in an electric field before being mass separated and measured in the 4π beta detector tape station or a 4π neutron counter [15]. Table 1 and Figure 1 describe the geometries of the targets tested.

Table 1. Description of target/converter assemblies tested at ISOLDE. Refer to Fig. 1 and Fig. 6.

Material and Identification number	Converter Material	Converter Length L (mm)	Converter Diameter D (mm)	S (mm)	P (mm)	Estimated Total Intensity (protons)
UC ₂ -C_183	Ta	215	10	21	0	2.5×10^{18}
ThO ₂ _184*	Ta	130	10	21	-10	3×10^{16}
UC ₂ -C_190	W	150	12.5	23	25	1×10^{17}
UC ₂ -C_201	Ta	150	10	21	0	6×10^{18}
UC ₂ -C_208	W	150	20	26	0	1.5×10^{18}
UC ₂ -C_213	W	100	12.5	23	-20	1×10^{16}

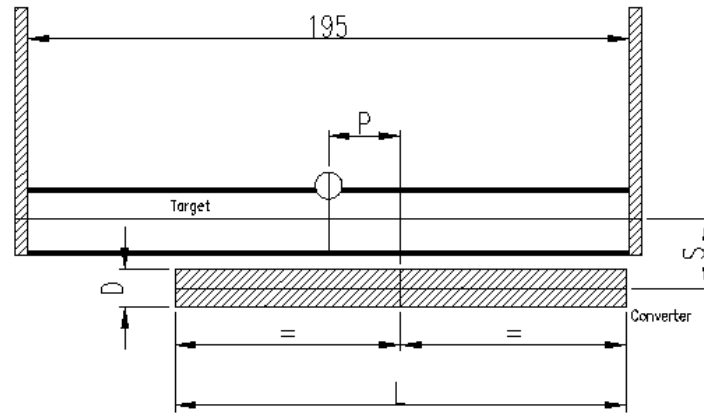

Fig. 1. A schematic view of target and converter assembly.

Targets UC₂-C_190 and UC₂-C_213 were equipped with a plasma ion source with a cold transfer line. This ion source is used to measure the production yields of noble gases [16].

For target UC₂-C_190, the average ratios of the beta count rate of Kr and Xe nuclei produced by spallation neutrons from the converter were compared to nuclei produced by protons directly on the target [17]. Although the yields produced by spallation neutrons are lower, the difference in ratio between the neutron-rich nuclei and neutron deficient nuclei shows that there is a gain in purity of neutron-rich ion beams produced by fission from spallation neutrons.

Targets UC₂-C_201 and UC₂-C_208 were equipped with a Resonant Ionization Laser Ion Source RILIS [18]. This highly selective ion source can be tuned to improve the ratio of laser-ionized elements to surfaced ionized isobars. In the case of neutron-rich fission products, this ratio can be further improved by using spallation neutrons to induce fission. For target UC₂-C_208, both RILIS and converter were used for the production of neutron-rich Cd while suppressing Cs and In isobars.

Three different converter geometries for neutron production were simulated using MARS. The proton beam used for the simulation has a radial dimension (1 sigma) of 0.22 cm, zero divergence and no time dispersion. The proton energies are 1 and 1.4 GeV (kinetic) and the

proton beam is generated as mono-energetic. The interaction of protons with the matter, the particle production and the energy deposition are simulated using MARS interfaced with MCNP4C. This configuration provides the proper tracking and interaction of neutrons below the energy of 14.5 MeV.

Experimental Results

The Cs yields in Fig. 2 show that the production rate from spallation neutrons is a factor of 7 lower for neutron-rich isotopes and up to a factor of 50 lower when approaching stability. For neutron-rich ion beams, this difference in ratio means the reduction of isobaric contamination from other fission products normally produced from direct bombardment of the target.

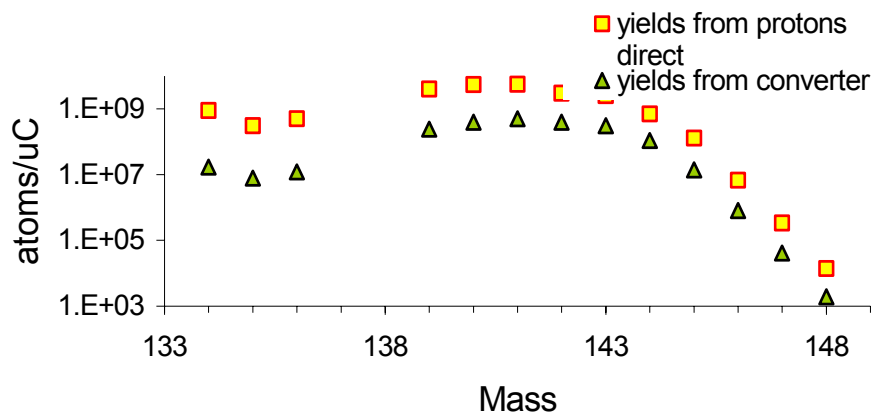

Fig. 2. Cs yields, from target UC₂-C_183, produced by protons directly on the target or from spallation neutrons.

In Fig. 3, the ratio of Cs yields produced by direct bombardment and spallation neutrons for targets UC₂-C_183 and UC₂-C_208 shows that using a tungsten converter improves the production rates for neutron-rich isotopes. Even when considering the variations between the two targets, e.g. ion source, proton beam profile and geometry, the use of a tungsten converter improves the production rates by a factor of 2 compared to a tantalum converter. This corresponds to the MARS simulation where a neutron flux gain of 1.39 from tungsten was calculated for identical conditions.

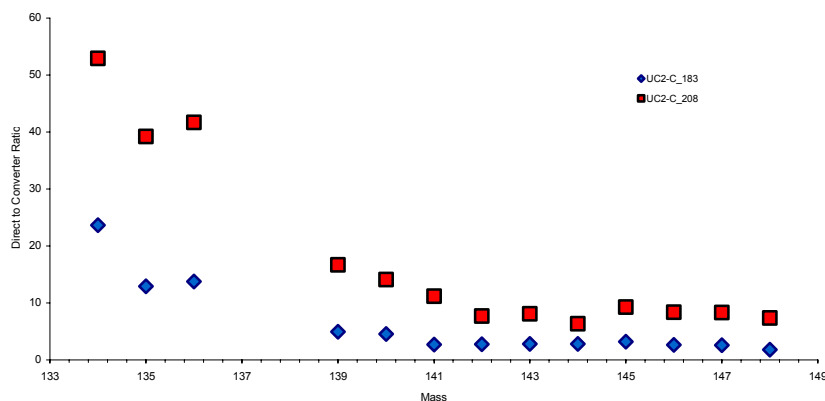

Fig. 3. Ratio of Cs yields produced directly on the target to Cs yields from spallation neutrons.

The MARS simulations also show a factor 1.4 increase in the neutron flux when using 1.4 GeV protons instead of 1 GeV. This calculation reflects the ratio of Xe yields from spallation

neutrons between 1 GeV and 1.4 GeV [13]. Examples of the angular neutron flux distribution and the energy distribution as calculated by the MARS code are given in Figures 4 and 5 respectively.

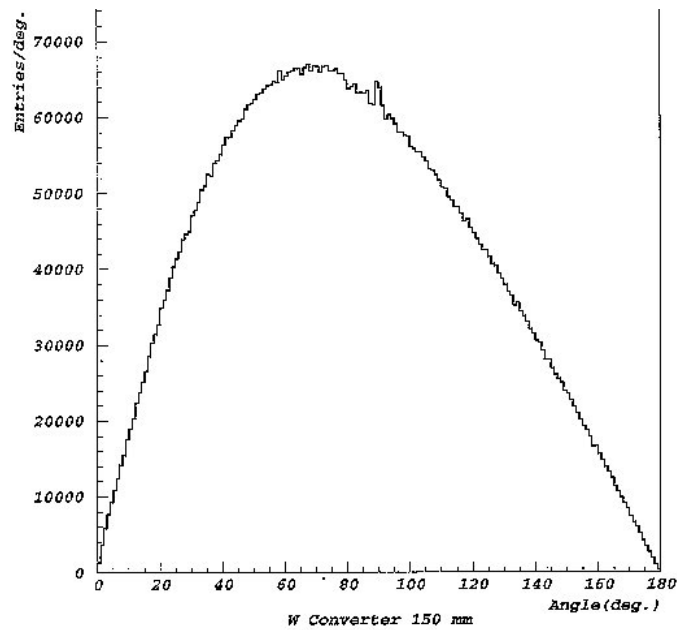

Fig. 4. Neutron flux distribution for a 150 mm long tungsten converter, 12.5 mm diameter and 1.4 GeV proton beam.

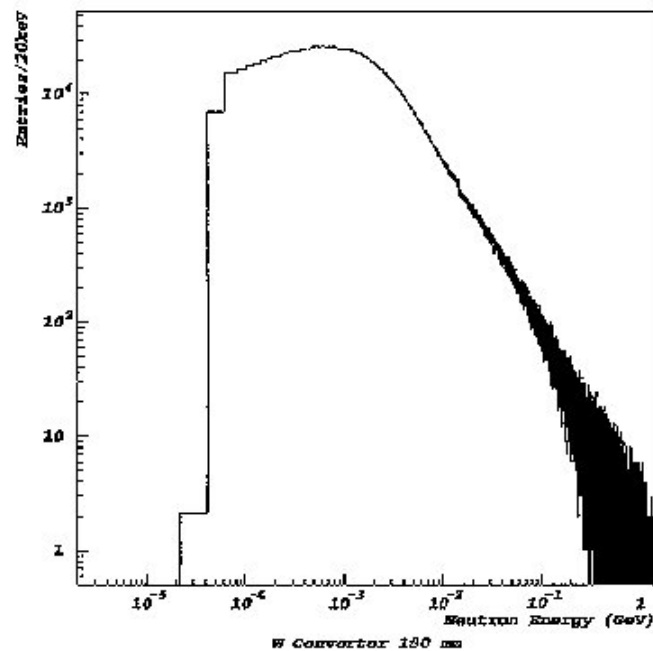

Fig. 5. Neutron energy distribution for a 150 mm long tungsten converter, 12.5 mm diameter and 1.4 GeV proton beam.

Inspection of the six targets after irradiation showed the tantalum converters had been damaged or displaced by the proton beam. In the case of ThO₂ 184, the tantalum converter had been dislodged causing a short circuit that prevented the ion source from reaching its nominal working temperature. Figures 6 and 7 give an indication of the damage suffered by the tantalum converters after intensive proton beam bombardment.

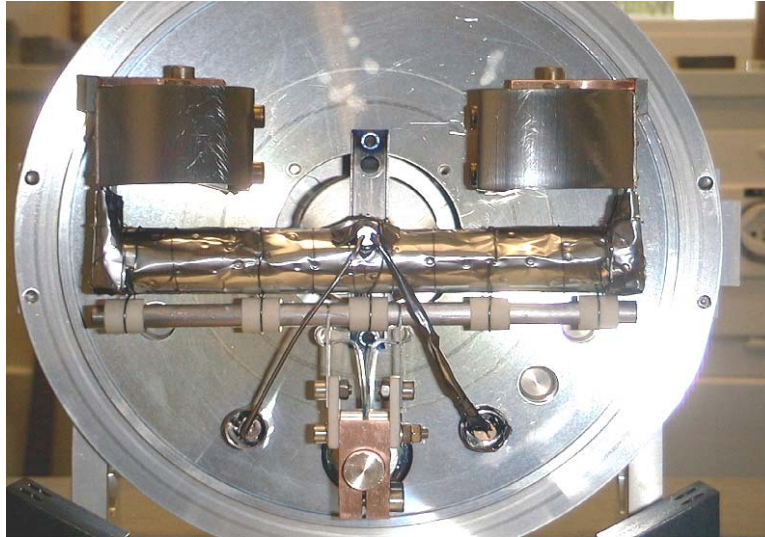

Fig. 6. Target UC₂-C_183 before irradiation.

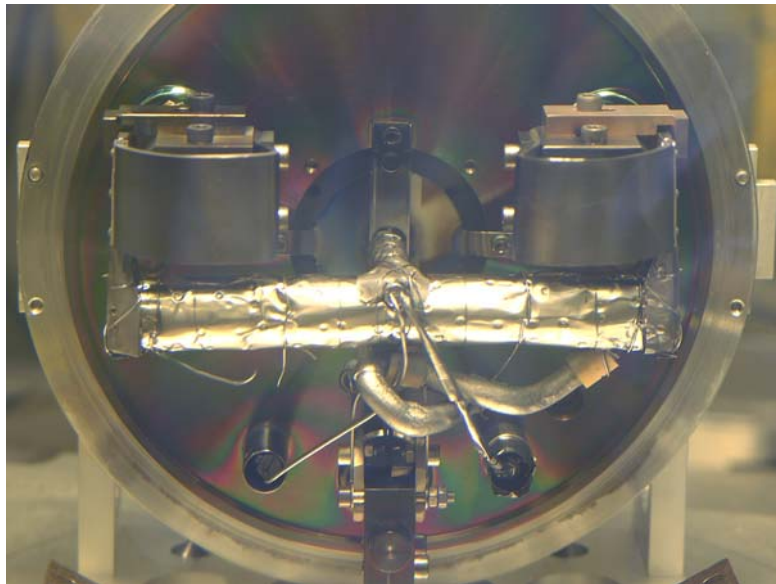

Fig. 7. Target UC₂-C_183 after receiving 2.5×10^{18} protons with a focused proton beam of 3×10^{13} protons per pulse.

Conclusion

The use of spallation neutrons to create fission has the advantage of eliminating the energy deposited by the proton beam in the target, suppressing isobaric contamination and reducing the mechanical stress on the target. The lower production rates of neutron-rich isotopes can be attributed to the improvised and non-ideal geometry of the test target/convertor assemblies. However, the results do show the potential for an optimized cylindrical target design. The tests at ISOLDE have shown the advantages of tungsten over tantalum as a convertor material and the autopsies have revealed the need for further improvement in the mechanical design of actual convertor targets. The MARS code simulations are coherent with the test results and are proving to be a valuable tool for the calculations required to design a dedicated target for neutron-rich beams from fission.

References

- [1] EU-RTD project EURISOL (HPRI-CT-1999-50001)
- [2] E. Kugler, *Hyperfine Interactions* 129 (2000) 23 – 42.
- [3] EU-RTD project TARGISOL (HPRI-CT-2001-50033).
- [4] N.V. Mokhov, S.I. Striganov, A. Van Ginneken, S.G. Mashnik, A.J. Sierk and J. Ranft, "MARS Code Developments", 4th Workshop on Simulating Accelerator Radiation Environments, SARE-4, Knoxville, USA, 14.-15.9.1998, FERMILAB-PUB-98-379, nucl-th/9812038.
- [5] N.V. Mokhov, "The Mars Code System User's Guide", Fermilab-FN-628(1995).
- [6] N.V. Mokhov, "MARS Code Developments, Benchmarking and Applications", Fermilab-Conf-00-066 (2000).
- [7] O.E. Krivosheev and N.V. Mokhov, "A New MARS and its Applications", Fermilab-Conf-98/43 (1998).
- [8] J.S. Hendrics, "MCNP4C" LANL Memo X-5; JSH-2000-3
- [9] J.F. Briesmesteir, ed. "MCNP - A General Montecarlo N-Particle Transport Code, Version 4C", LA-13709-M.
- [10] NuPECC Report on Radioactive Nuclear Beam Facilities, R. Bennet et al. NuPECC (2000).
- [11] H. L. Ravn, Advanced Target Concept for Production of Beams of Neutrinos and Radioactive Ions. These proceedings.
- [12] J. Nolen et al., Liquid Lithium cooling for a 100kW ISOL and fragmentation targets To be published in *Nuclear Phys. A*
- [13] J. Lettry, Effects of Thermal Shocks on the Release of Radioisotopes from ISOLDE targets. These proceedings.
- [14] U. Koester, *Radiochim. Acta* 89, 749 – 756 (2001).
- [15] U.C. Bergmann et al, *Nucl. Phys. A* 658 (1999) 129-145.
- [16] U.C. Bergmann et al., Production Yields of Noble-gas Isotopes from ISOLDE UCx/Graphite Targets. These proceedings.
- [17] R. Catherall et al., to be published in *Proc. Exotic Nuclei and Atomic Masses (ENAM-01)*.
- [18] J. Lettry, *Rev. Sci. Instrum.* : 69 (1998) no.2 - pp.761-763.