

**EUROPEAN ORGANIZATION FOR NUCLEAR RESEARCH****CERN - PS DIVISION****CERN/PS 2002-063 (RF)  
CLIC Note 536****A NEW DAMPED AND TAPERED ACCELERATING STRUCTURE FOR CLIC**

J-Y. Raguin, D. Schulte, I. Syratchev, I. Wilson, W. Wuensch

*Abstract*

The main performance limits when designing accelerating structures for the Compact Linear Collider (CLIC) for an average accelerating gradient above 100 MV/m are electrical breakdown and material fatigue caused by pulsed surface heating. In addition, for stable beam operation, the structures should have low short-range transverse wakefields and much-reduced transverse and longitudinal long-range wakefields. Two damped and tapered accelerating structures have been designed. The first has an accelerating gradient of 112 MV/m with the surface electrical field limited to 300 MV/m and the maximum temperature increase limited to 100°C. The second, with an accelerating gradient of 150 MV/m, has a peak surface electrical field of 392 MV/m and a maximum temperature increase of 167°C. Innovations to the cell and damping waveguide geometry and to the tapering of the structures are presented, and possible further improvements are proposed.

*XXIst International Linear Accelerator Conference, 9-23 August 2002,  
Gyeongju (Kyongju), Korea*

Geneva, Switzerland  
10 September 2002

# A NEW DAMPED AND TAPERED ACCELERATING STRUCTURE FOR CLIC

J.-Y. Raguin, D. Schulte, I. Syratchev, I. Wilson and W. Wuensch  
CERN, Geneva, Switzerland

## Abstract

The main performance limits when designing accelerating structures for the Compact Linear Collider (CLIC) for an average accelerating gradient above 100 MV/m are electrical breakdown and material fatigue caused by pulsed surface heating. In addition, for stable beam operation, the structures should have low short-range transverse wakefields and much-reduced transverse and longitudinal long-range wakefields. Two damped and tapered accelerating structures have been designed. The first has an accelerating gradient of 112 MV/m with the surface electrical field limited to 300 MV/m and the maximum temperature increase limited to 100 °C. The second, with an accelerating gradient of 150 MV/m, has a peak surface electrical field of 392 MV/m and a maximum temperature increase of 167 °C. Innovations to the cell and damping waveguide geometry and to the tapering of the structures are presented, and possible further improvements are proposed.

## 1 INTRODUCTION

The development of a multi-bunch accelerating structure for the CLIC main linac that can operate with an average gradient above 100 MV/m is complicated by the very strict constraints placed on the long- and short-range wakefields. Beam dynamics simulations have shown that to avoid emittance blow-up along the linear collider the amplitude of the transverse wakefield during the first 0.67 ns (the time between bunches in the RF train) must decrease by two orders of magnitude. Such a suppression of transverse wakefields has been demonstrated with a structure called TDS (Tapered Damped Structure) tested in a recent ASSET experiment [1]. The heavy damping in this  $2\pi/3$ -quasi-constant gradient structure was achieved by coupling each of the 150 cells to a set of four individually terminated waveguides.

Whereas the design considerations of the TDS were mainly concerned with a drastic reduction of the transverse wakefields [1, 2], the present study attempts to tackle the issue of the performance limits due to the high surface electric fields [3] and to the pulsed surface heating as well. The outcome of this study is the design of two  $2\pi/3$ -quasi-constant gradient structures called XDS (conveX Damped Structure) of 81 and 84 cells, respectively. The first structure (XDS 1) has an average loaded accelerating gradient of about 110 MV/m and a peak surface electric field of 300 MV/m. The maximum temperature rises due to pulse surface heating and for a pulse length of 130 ns are about 100 °C and 75 °C in the unloaded and loaded cases, re-

spectively. The average loaded accelerating gradient of the second structure (XDS 2) is 150 MV/m and its peak surface electric field is 390 MV/m. Maximum temperature rises in these cases are about 165 °C (unloaded) and 125 °C (loaded). For the TDS, the maximum temperature rise was higher than 800 °C. This remarkable decrease of the pulse surface heating has been obtained by optimizing the shape of the outer cell walls while the decrease of the peak surface electric field has been achieved by adopting an elliptical iris tip profile instead of circular. For both structures the dimensions of the first cells are identical. Similarly, both last cells are also identical. As for the reduction of the transverse wakefields, it is achieved through a combination of detuning and damping. The cell irises radii vary linearly from 2.0 mm to 1.5 mm while the iris thickness is tapered, also linearly, from 0.55 mm to 1.0 mm. The damping is obtained by coupling each cell to four identical T-cross waveguides, the cutoff frequency of the first propagating mode being about 32 GHz, above the 29.985 GHz fundamental but still well below all the higher order modes. This produces a  $Q$  of below 55 for the lowest dipole band.

## 2 DESIGN CONSIDERATIONS

Parametric studies performed on constant-impedance classical accelerating structures (no damping waveguides) revealed that, for a constant iris thickness, the ratio of the peak surface electric field to the accelerating gradient  $E_{peak}/E_{acc}$ , and the ratio of the peak surface magnetic field to the accelerating gradient  $H_{peak}/E_{acc}$  of the fundamental mode, decrease when the iris aperture is reduced. Moreover, for a fixed iris aperture, an increase of the iris thickness leads to lower  $E_{peak}/E_{acc}$  but higher  $H_{peak}/E_{acc}$  [4]. The inspection of the electric field mode pattern on a circularly rounded iris shows that the peak surface field is not located at the tip but is located symmetrically with respect to the plane of symmetry of the iris. Consequently, a further reduction of  $E_{peak}/E_{acc}$  can be achieved by decreasing the local curvature radius at the position of these maxima, leading to an elliptical profile of the tip of the iris. The reduction of  $E_{peak}/E_{acc}$  achieved by this means is markedly more pronounced as the iris aperture decreases. The effect on the shunt impedance, on the  $R'/Q$  and on the  $Q$  of the fundamental is quite negligible but does slightly effect the group velocity  $v_g$ .

To reduce the longitudinal and transverse short-range wakefields, it is well known that larger iris radii are more favourable. Moreover, recent studies revealed that large iris radii are also more advantageous for CLIC luminosity be-

cause of the limitations arising from the damping rings and the beam delivery system [5]. As for the reduction of long-range wakefields, the adopted scheme is a combination of slight detuning and heavy damping. The detuning, which consists in inducing a frequency spread in the dipole bands (the most dangerous higher-order modes belong to the first and second dipole bands), is realized here by tapering the iris radii as well as the iris thicknesses. The damping is achieved by coupling each cell to a set of four radial waveguides. However, due to the broken azimuthal symmetry of the cells, the concentration of the magnetic-field lines in the vicinity of the wide coupling holes leads to a dramatic increase of the ratio  $H_{peak}/E_{acc}$  if the profile of the outer-cell wall is not optimized. Previous designs had cells with a conventional concave shape of the outer wall. The maximum temperature rise can be brought back to more acceptable values, albeit above the temperature rise of a conventional cell without coupling waveguides, by adopting a convex shape, as a matter of fact a combination of straight and elliptical sections (see Figure 1). However, with an optimized outer-wall shape, larger coupling holes, desirable for more damping, still leads anyway to an increase of the ratio  $H_{peak}/E_{acc}$ .



Figure 1: Topology of the XDSs cell and damping waveguides.

### 3 DESIGN RESULTS

The geometry of a cell of the XDS structures is shown in Figure 2. The requirement imposed by an acceptable short-range wake level led to an average iris radius  $a$  of 1.75 mm with a linear variation from 2 mm at the head of the structure to 1.5 mm at the end. The iris thickness  $d$  varies linearly from 0.55 mm to 1 mm. In the absence of coupling waveguides, computations made with URMEL [4] show that the shunt impedance and the  $R'/Q$  increases from 113 M $\Omega$ /m and 26 k $\Omega$ /m, respectively, to 123 M $\Omega$ /m and 32 k $\Omega$ /m while the  $Q$  decreases from 4340 to 3880. The group velocity  $v_g$  decreases from 0.086  $c$  to 0.029  $c$ . The ratio  $H_{peak}/E_{acc}$  is fairly constant and is about 3.1 mA/V. The ratio  $E_{peak}/E_{acc}$  decreases from 2.55 to 1.75 when the el-

lipticity of the iris shape varies from 1.3 to 1.8.

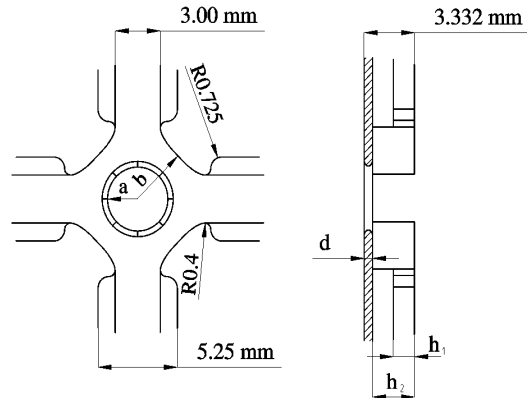

Figure 2: Geometry of the XDSs cell and damping waveguides.

The T-cross coupling waveguides and the convex shape of the cell outer wall bring modifications to the fundamental mode characteristics. For the first cell, with a width of coupling hole fixed at 3.0 mm,  $R'/Q$ ,  $Q$  and  $v_g$  are 25.2 k $\Omega$ /m, 3740 and 0.081  $c$ , respectively. For the last cell and with the same coupling hole width,  $R'/Q$ ,  $Q$  and  $v_g$  are 32.1 k $\Omega$ /m, 3375 and 0.026  $c$ , respectively. Having fixed the widest width of the waveguide to 5.25 mm, the two heights  $h_1$  and  $h_2$  (see Figure 2) were chosen so that the cutoff frequency of the first propagating mode is between 32 GHz and 32.5 GHz. Whereas  $E_{peak}/E_{acc}$  is not affected by the damping waveguides,  $H_{peak}/E_{acc}$  increases to 4.5 mA/V and 4.4 mA/V for the first and last cells, respectively. The distribution of the surface magnetic field normalized to the accelerating gradient  $H_{surf}/E_{acc}$  for the first cell walls is shown in Figure 3.

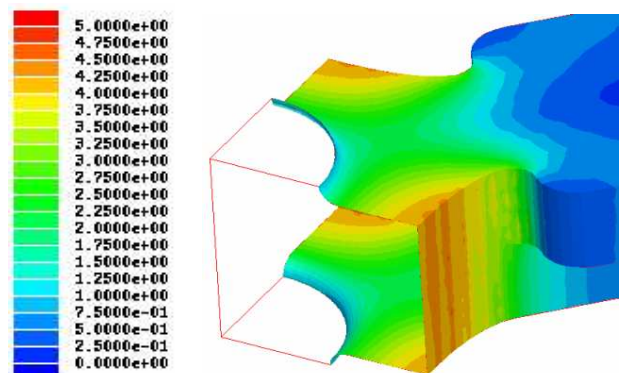

Figure 3: Ratio  $H_{surf}/E_{acc}$  on the first cell walls of the XDSs

To assess the damping and detuning properties of the cells, the technique presented in [6], by means of which the three-dimensional dispersion diagram is obtained and where the distance of the main dipole branch from the speed-of-light line is computed, was used. Such an estimation is shown on Figure 4 for the first and last cells. The frequencies at which minima are observed correspond approximately to maxima in the real part of the transverse impedances. Complementary information was obtained with the code GdfidL [7] by computing the trans-

verse impedances associated with the first, middle and last cell of the structures from a FFT of the transverse wakes (Figure 5). The  $Q$ s for the lowest dipole band, estimated from the transverse wakes, are 52, 51 and 44 for the first, middle and last cells. The transverse wakes of the XDS 1 structure (81 cells) computed in the uncoupled model approximation is shown in Figure 6.

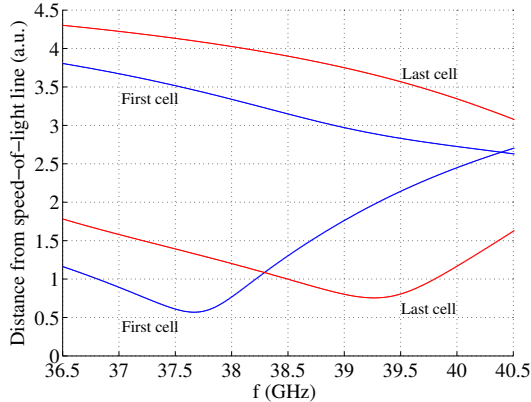

Figure 4: Distances from the speed-of-light line to the dipole branches versus frequency.

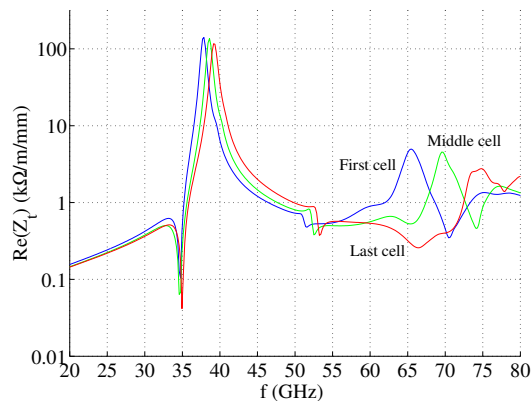

Figure 5: Real part of the transverse impedance versus frequency computed with GdfidL for the first, middle and last cells of the XDSs.

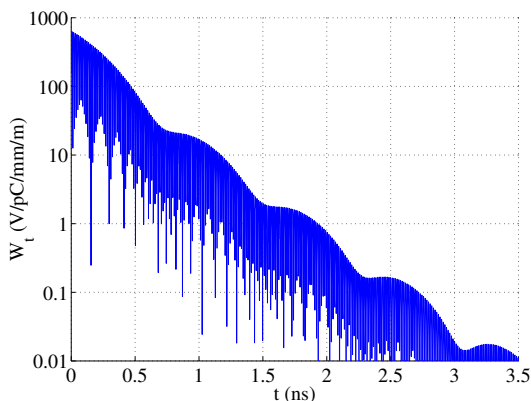

Figure 6: Transverse wakefields for XDS 1.

The unloaded and loaded accelerating gradient and peak surface electric field profiles for the two structures are shown in Figure 7. For the XDS 1, with an average loaded accelerating gradient of 112 MV/m, the RF-to-beam efficiency is 32 % and the required input power per section is

77 MW. For the XDS 2, the RF-to-beam efficiency is 27 % and the input power per section is 132 MW with an average loaded accelerating field of 150 MV/m.

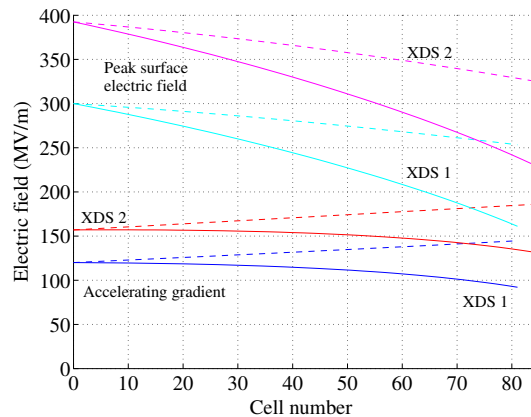

Figure 7: Unloaded (- -) and loaded (—) accelerating gradients and peak surface electric fields for the XDSs.

## 4 FURTHER IMPROVEMENTS

Further improvements in the fundamental mode characteristics can be achieved by rounding the cell outer walls. Preliminary results show an increase in  $Q$  of about 10 % for the new cells. The resultant decrease in the temperature rise can be as high as 10 °C. Complementary studies to estimate the variation of the frequency spread in the dipole bands induced by these modifications and to re-evaluate the damping properties for further reducing the long-range transverse wakes are at present under scrutiny.

## 5 ACKNOWLEDGEMENTS

The authors are indebted to W. Bruns for having performed computations of the structures with the code GdfidL. Special thanks are also extended to S. Heikkinen for having generated some of the figures.

## 6 REFERENCES

- [1] I. Wilson and W. Wuensch, “The CLIC Main Linac Accelerating Structure”, Proc. LINAC 2000, pp. 419-421, Monterey, 2000.
- [2] M. Dehler, “Modeling a 30 GHz Loaded Detuned Structure for the Compact Linear Collider (CLIC)”, CLIC Note 358, CERN, 1998.
- [3] H. H. Braun, S. Döbert, I. Syratchev, M. Taborelli, I. Wilson and W. Wuensch, “CLIC High-Gradient Test Results”, these proceedings.
- [4] H. H. Braun, private communication.
- [5] D. Schulte, “Luminosity Limitations at the Multi-TeV Linear Collider Energy Frontier”, to be published in Proc. EPAC 2002, Paris, 2002.
- [6] J.-Y. Raguin, J. Prochnow and W. Wuensch, “A New technique to Compute Long-range Wakefields in Accelerating Structures”, to be published in Proc. EPAC 2002, Paris, 2002.
- [7] W. Bruns, “The GdfidL Electromagnetic Field Simulator”, [www.gdfidl.de](http://www.gdfidl.de).