

EUROPEAN ORGANIZATION FOR NUCLEAR RESEARCH

CERN-EP/2002-024

12 March 2002

Induced Signals in Resistive Plate ChambersW. Riegler¹⁾**Abstract**

We derive theorems for induced signals on electrodes embedded in a medium with a position and frequency dependent permittivity $\varepsilon(\vec{x}, s)$ and conductivity $\sigma(\vec{x}, s)$ that are connected with arbitrary discrete elements. The problem is treated using the quasi-static approximation of Maxwell's equations for weakly conducting media [1][2]. The induced signals can be derived by time dependent weighting fields and potentials and the result is the same as the one given in [3]. We also show how these time dependent weighting fields can be derived from electrostatic solutions. Finally we will apply the results to Resistive Plate Chambers (RPCs) where we discuss the effects of the resistive plates and thin resistive layers on the signals induced on plane electrodes and strips.

Submitted to Nuclear Instruments and Methods

¹⁾ EP Division, CERN, CH-1211 Geneva 23, Switzerland

1 Introduction

Most particle detectors can be approximated by assuming perfectly conducting electrodes surrounded by insulating materials. In that case all the electric fields are instantaneous and the current induced on a grounded electrode by a charge Q moving along a trajectory $\vec{x}(t)$ in the detector can be calculated by Ramo's theorem [4][5]:

$$I(t) = Q\vec{E}(\vec{x}(t))\vec{\dot{x}}(t) \quad (1)$$

where $\vec{E}(\vec{x})$ is the electric field in the detector if the charge is removed, the electrode in question is put to unit voltage and all other electrodes are grounded. In a detector with resistive elements the electric fields will show a time dependence and the above statement will not hold. In this report we will derive a similar theorem for detectors containing resistive elements, i.e. we will answer the question: what are the voltages induced by a time varying charge density $\rho(\vec{x}, t)$ on electrodes embedded in a medium with arbitrary conductivity $\sigma(\vec{x}, s)$ and permittivity $\varepsilon(\vec{x}, s)$ that are connected with arbitrary reactive elements (Fig. 1).

If we answer the question for electrodes embedded in a general medium without discrete elements, as shown in Figure 4, we have already solved the problem for connected electrodes since we can assume the discrete elements to be contained in the $\varepsilon(\vec{x}, s)$ and $\sigma(\vec{x}, s)$.

Finally the results will be applied to signals in Resistive Plate Chambers.

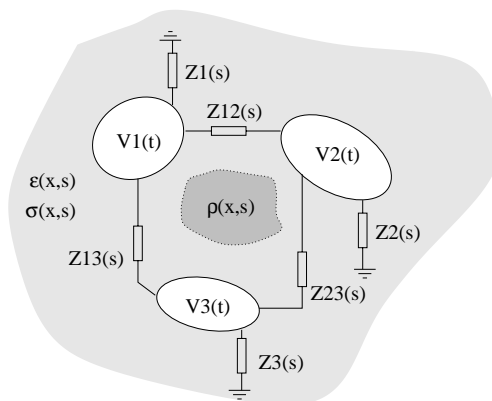

Figure 1: Electrodes embedded in a medium with conductivity $\sigma(\vec{x}, s)$ and $\varepsilon(\vec{x}, s)$ and connected with an arbitrary reactive network. The time varying charge density induces voltages on the electrodes.

2 Quasi-static Approximation of Maxwell's Equations

Maxwell's equations for a linear isotropic medium with permittivity ε and conductivity σ are given by

$$\vec{\nabla} \vec{D} = \rho \quad \vec{D} = \varepsilon \vec{E} \quad \vec{\nabla} \vec{B} = 0 \quad \vec{B} = \mu \vec{H} \quad (2)$$

$$\vec{\nabla} \times \vec{E} = -\frac{\partial \vec{B}}{\partial t} \quad \vec{\nabla} \times \vec{H} = \vec{j}_e + \sigma \vec{E} + \frac{\partial \vec{D}}{\partial t} \quad (3)$$

where \vec{j}_e is an 'externally impressed' current that is connected with an 'external' charge density by $\vec{\nabla} \vec{j}_e = -\partial \rho_e / \partial t$. Assuming weak conductivity σ we can set

$$\vec{\nabla} \times \vec{E} = -\frac{\partial \vec{B}}{\partial t} = 0 \quad \Rightarrow \quad \vec{E} = -\vec{\nabla} \Phi \quad (4)$$

and by taking the divergence of the second equation in (3) we find

$$\vec{\nabla} [\sigma(\vec{x}, s) \vec{\nabla}] \Phi(\vec{x}, t) + \vec{\nabla} [\varepsilon(\vec{x}, s) \vec{\nabla}] \frac{\partial \Phi(\vec{x}, t)}{\partial t} = -\frac{\partial \rho_e(\vec{x}, t)}{\partial t} \quad (5)$$

Performing a Laplace transform and assuming that $\Phi(\vec{x}, t = 0) = 0$ and $\rho_e(\vec{x}, t = 0) = 0$ we have

$$L[\Phi(\vec{x}, t)] = \bar{\Phi}(\vec{x}, s) \quad L\left[\frac{\partial \Phi(\vec{x}, t)}{\partial t}\right] = s\bar{\Phi}(\vec{x}, s) \quad L\left[\frac{\partial \rho_e(\vec{x}, t)}{\partial t}\right] = s\bar{\rho}_e(\vec{x}, s) \quad (6)$$

and the equation becomes

$$\vec{\nabla} [\varepsilon(\vec{x}, s) \vec{\nabla}] \bar{\Phi}(\vec{x}, s) = -\bar{\rho}_e(\vec{x}, s) \quad \text{with} \quad \varepsilon(\vec{x}, s) = \varepsilon(\vec{x}, s) + \frac{1}{s} \sigma(\vec{x}, s) \quad (7)$$

This equation has the same form as the Poisson equation for electrostatic problems. Let us assume that we have a general charge density with a time dependence according to

$$\rho_e(\vec{x}, t) = \rho(\vec{x}) \delta(t) \quad \rightarrow \quad \bar{\rho}_e(\vec{x}, s) = \rho(\vec{x}) . \quad (8)$$

To find the corresponding time dependent potential, the equation to solve is

$$\vec{\nabla} [\varepsilon(\vec{x}, s) \vec{\nabla}] \bar{\Phi}(\vec{x}, s) = -\rho(\vec{x}) \quad (9)$$

From this we can conclude the following statements:

If we know the electrostatic potential for the charge density $\rho(\vec{x})$ in a medium with given $\varepsilon(\vec{x})$ we obtain the time dependent potential for a charge density $\rho(\vec{x})\delta(t)$ in a medium with conductivity $\sigma(\vec{x}, s)$ and permittivity $\varepsilon(\vec{x}, s)$ by replacing ε with $\varepsilon + \sigma/s$ and performing the inverse Laplace transform.

Since the Green's function for the electrodynamic problem is the potential for the source $\delta(\vec{x})\delta(t)$ the same conclusion applies:

If we know the Green's function for a medium with given $\varepsilon(\vec{x})$ we obtain the time dependent Green's function for a medium with conductivity $\sigma(\vec{x}, s)$ and permittivity $\varepsilon(\vec{x}, s)$ by replacing ε with $\varepsilon + \sigma/s$ and performing the inverse Laplace transform.

In the next section we will show two simple examples.

2.1 Point Charge in infinite Space

The Green's function for a homogeneous medium characterized by a constant dielectric constant ε is given by

$$\overline{G}(\vec{r}) = \frac{1}{4\pi\varepsilon|\vec{r}|} \quad (10)$$

Replacing ε by $\varepsilon + \sigma/s$ and performing the inverse Laplace transform we find the Green's function for a medium with constant conductivity σ and permittivity ε as

$$G(\vec{r}, t) = \frac{1}{4\pi\varepsilon|\vec{r}|} \left(\delta(t) - \frac{\sigma}{\varepsilon} e^{-\frac{t}{\tau}} \right) \quad \tau = \frac{\varepsilon}{\sigma} \quad (11)$$

E.g. putting at time $t = 0$ a charge density $\rho(\vec{r})$ into the medium i.e. $\rho_e(\vec{r}, t) = \rho(\vec{r})\Theta(t)$ the time dependent potential is given by

$$\Phi(\vec{r}, t) = \int_V \int_0^t G(\vec{r} - \vec{r}', t - t') \rho(\vec{r}') \Theta(t') dt' d^3r' = \frac{e^{-\frac{t}{\tau}}}{4\pi\varepsilon} \int_V \frac{\rho(\vec{r}')}{|\vec{r} - \vec{r}'|} d^3r' \quad (12)$$

The potential is equal to the electrostatic one, but 'destroyed' with the time constant $\tau = \sigma/\varepsilon$.

2.2 Point Charge in an infinite Half-Space

Let's assume two infinite half spaces with different constant σ, ε and a point charge Q at the boundary (Figure 2). This electrostatic solution ($\sigma = 0$) is given by [7]

$$\overline{\Phi}(\vec{r}) = \frac{Q}{4\pi} \frac{2}{(\varepsilon_1 + \varepsilon_2)} \frac{1}{|\vec{r}|} \quad (13)$$

This has the same form as the above solution 10, so the potential for a point charge Q created at $t = 0$ we have

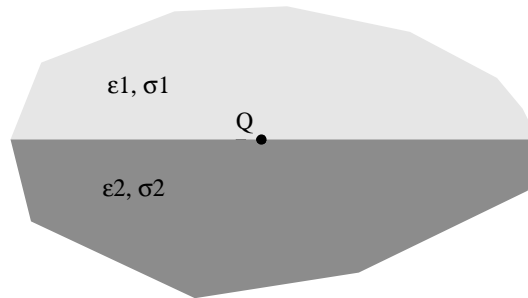

Figure 2: Point charge on the boundary between two infinite half spaces of constant σ and ε .

$$\Phi(\vec{r}, t) = \frac{2Q}{4\pi(\varepsilon_1 + \varepsilon_2)|\vec{r}|} e^{\frac{-t}{\tau}} \quad \tau = \frac{\varepsilon_1 + \varepsilon_2}{\sigma_1 + \sigma_2} \quad (14)$$

If we set $\varepsilon_1 = \varepsilon_0$, $\sigma_1 = 0$, $\varepsilon_2 = \varepsilon_r \varepsilon_0$ and $\sigma_2 = \sigma$, the geometry is equal to a charge sitting on the resistive plate in a Resistive Plate Chamber (RPC). With typical numbers of $1/\sigma = 10^{10} \Omega\text{cm}$ and $\varepsilon_r = 5$ we find a time constant of $\tau = 5.3$ msec, so the charge is 'removed' very slowly compared to the RPC signal duration of a few nanoseconds.

3 Generalized Green theorem and Impedance Matrix

In order to apply the quasi-static approximation to the problem of induced signals we need a generalization of Green's theorem and the capacitance matrix. If we have N insulated electrodes on potentials V_i (Figure 3a), the charges on the electrodes are given by

$$Q_i = \sum_j c_{ij} V_j \quad (15)$$

where c_{ij} is the capacitance matrix. This is derived from Green's second theorem [7] which reads as

$$\int_V (\psi \Delta \phi - \phi \Delta \psi) dV = \int_S (\psi \vec{\nabla} \phi - \phi \vec{\nabla} \psi) d\vec{A} \quad (16)$$

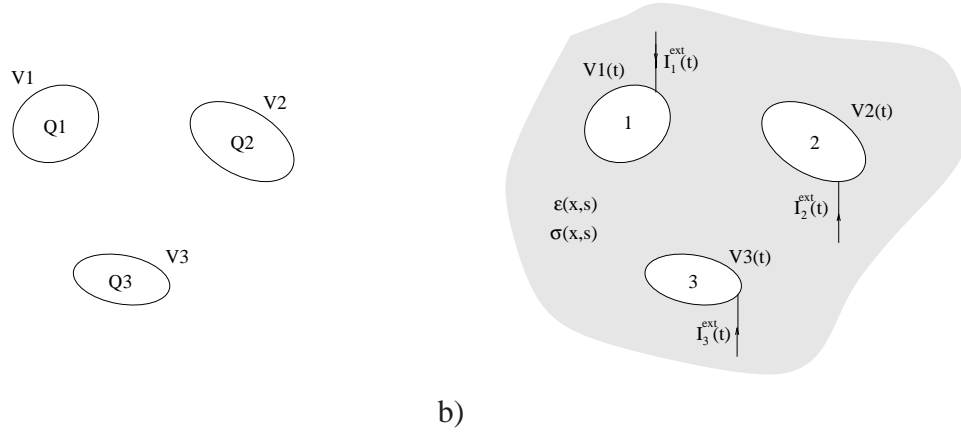

Figure 3: (a) The voltages V_i and charges Q_i on insulated electrodes are connected through the capacitance matrix c_{ij} . (b) The voltages V_i and currents I_i^{ext} flowing onto electrodes embedded in a general conducting medium are connected by the impedance matrix $Z_{ij}(s)$.

Now we derive a similar relation for electrodes in a medium with $\epsilon(\vec{x}, s)$ and $\sigma(\vec{x}, s)$ (Figure 3b). We want to know the voltages $V_i(t)$ on the electrodes for given currents put on the electrodes. Since there are no charges in between the electrodes the equation to solve is

$$\vec{\nabla}[\epsilon(\vec{x}, s) \vec{\nabla}] \bar{\Phi}(\vec{x}, s) = 0 \quad \bar{V}_i(s) = \bar{\Phi}(\vec{x}, s)|_{\vec{x}=S_i} \quad V_i(t) = L^{-1}[\bar{V}_i(s)] \quad (17)$$

S_i is the surface of electrode i and $\epsilon = \epsilon + \sigma/s$ as defined before. The charges on the electrode surfaces and the currents flowing from surfaces into the medium are given by

$$\bar{Q}_i(s) = \int_{S_i} \epsilon(\vec{x}, s) \frac{\partial \bar{\Phi}(\vec{x}, s)}{\partial \vec{n}} d\vec{A} \quad \bar{I}_i(s) = \int_{S_i} \sigma(\vec{x}, s) \frac{\partial \bar{\Phi}(\vec{x}, s)}{\partial \vec{n}} d\vec{A} \quad (18)$$

If the electrodes are not connected to an 'external' current source, the rate of change of the charge on the surface is only due to the current leaving through the surface, so the two are connected by

$$\frac{d}{dt}Q_i(t) + I_i(t) = 0 \quad \rightarrow \quad s\bar{Q}_i(s) + \bar{I}_i(s) = 0 \quad (19)$$

where we have assumed that at $t = 0$ the charges on the electrode surfaces are zero. If the electrodes are connected to external current sources the relation is

$$\frac{d}{dt}Q_i(t) + I_i(t) = I_i^{ext}(t) \quad \rightarrow \quad s\bar{Q}_i(s) + \bar{I}_i(s) = \bar{I}_i^{ext}(s) \quad (20)$$

We use a modified version of Green's theorem given by

$$\begin{aligned} & \int_V \left[\psi(\vec{x}) \vec{\nabla} [f(\vec{x}) \vec{\nabla}] \phi(\vec{x}) - \phi(\vec{x}) \vec{\nabla} [f(\vec{x}) \vec{\nabla}] \psi(\vec{x}) \right] d^3x \\ &= \int_S \left[\psi(\vec{x}) f(\vec{x}) \frac{\partial \phi(\vec{x})}{\partial \vec{n}} - \phi(\vec{x}) f(\vec{x}) \frac{\partial \psi(\vec{x})}{\partial \vec{n}} \right] d\vec{A} \end{aligned} \quad (21)$$

which holds for arbitrary functions ψ, f, ϕ . The surface S encloses the volume V . We replace ϕ with $\bar{\Phi}(\vec{x}, s)$, $f(\vec{x})$ with $\epsilon(\vec{x}, s)$ and can still chose ψ arbitrarily. We chose ψ to be the potential function of the geometry in Fig. 3b with still arbitrary boundary conditions $v_i(t)$ i.e.

$$\vec{\nabla}[\epsilon(\vec{x}, s) \vec{\nabla}] \bar{\psi}(\vec{x}, s) = 0 \quad \bar{v}_i(s) = \bar{\psi}(\vec{x}, s)|_{\vec{x}=S_i} \quad v_i(t) = L^{-1}[\bar{v}_i(s)] \quad (22)$$

Now we insert $\bar{\Phi}, \bar{\psi}$ and ϵ in Green's theorem, the volume V in between the electrodes is enclosed by the electrode surfaces $S = \sum S_i$ and a surface at infinity where all the fields are zero. The 'volume' terms in the first line of Eq. 21 are zero and we are left with the surface terms of the second line, so we get

$$\sum_i \bar{v}_i(s) [\bar{Q}_i(s) + \frac{1}{s} \bar{I}_i(s)] = \sum_i \bar{V}_i(s) [\bar{q}_i(s) + \frac{1}{s} \bar{i}_i(s)] \quad (23)$$

multiplying both sides with s and using Eq. 20 we have

$$\sum_i \bar{v}_i(s) \bar{I}_i^{ext}(s) = \sum_i \bar{V}_i(s) \bar{i}_i^{ext}(s) \quad (24)$$

which is called the 'reciprocity theorem'. If we now chose $\bar{v}_i(s)$ such that we put a constant voltage \bar{v}_{11} on electrode 1 (i.e. a voltage delta pulse $\bar{v}_{11} \delta(t)$ in the time domain), we have and 'external' current \bar{i}_1^{ext} on this electrode, voltages $\bar{v}_{1i}(s)$ on the other electrodes and no 'external' currents on the other electrodes and we find

$$V_1(s) = \frac{1}{\bar{i}_1^{ext}(s)} \sum_j \bar{v}_{1j}(s) \bar{I}_j^{ext}(s) \quad (25)$$

The same we can do with electrode 2 etc. and we therefore find the relation

$$\bar{V}_i(s) = Z_{ij}(s) \bar{I}_j^{ext}(s) \quad Z_{ij}(s) = \frac{\bar{v}_{ij}(s)}{\bar{i}_i^{ext}(s)} \quad (26)$$

where $\bar{i}_i^{ext}(s)$ is the current flowing onto electrode i when we put a constant voltage \bar{v}_{ii} on electrode i and $\bar{v}_{ij}(s), j \neq i$ are the corresponding voltages on the other electrodes. The matrix Z_{ij} is called the *characteristic impedance matrix* of the electrode system. We will use it later to find the connection between induced voltages and currents.

4 Induced Signals in Weakly Conducting Environment

Next we want to find the voltages and currents induced on the electrodes by a time varying charge density in between the electrodes. as shown in Fig. 4. The volume between the electrodes has a position and frequency dependent permittivity and conductivity. Using the quasi-static approximation we look for the solution of the following problem:

$$\vec{\nabla}[\epsilon(\vec{x}, s)\vec{\nabla}]\bar{\Phi}(\vec{x}, s) = -\bar{\rho}(\vec{x}, s) \quad \bar{V}_i(s) = \bar{\Phi}(\vec{x}, s)|_{\vec{x}=S_i} \quad V_i(t) = L^{-1}[\bar{V}_i(s)] \quad (27)$$

where S_i is the surface of electrode i and V_i is the voltage of electrode i . As before $\epsilon = \epsilon + \sigma/s$.

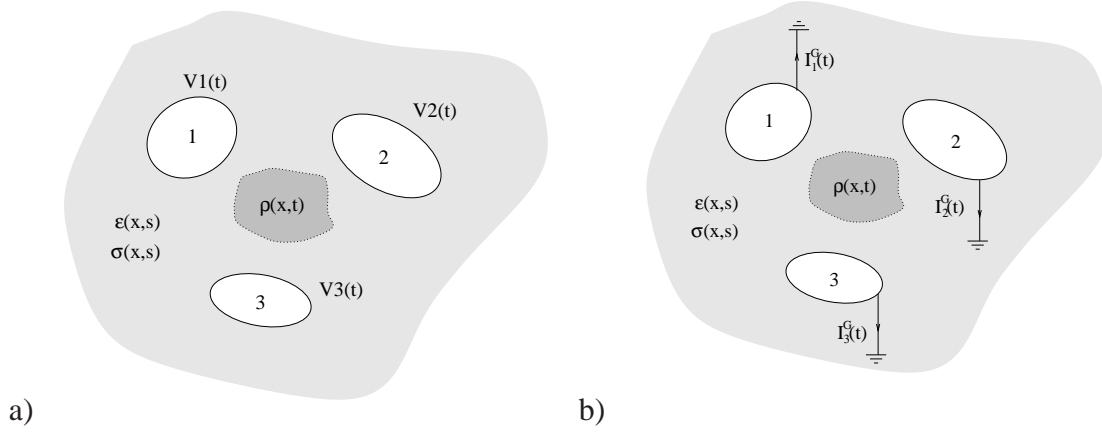

Figure 4: (a) The time dependent charge density induces voltages on the electrodes which are embedded in a general medium. (b) In case the electrodes are grounded the voltages are always zero and the charge distribution induces currents that are flowing between the electrodes and ground.

The problem has the formal solution

$$\bar{\Phi}(\vec{x}, s) = \int_V \bar{G}(\vec{x}, \vec{x}', s)\rho(\vec{x}', s)d^3x' \quad \vec{\nabla}(\epsilon(\vec{x}, s)\vec{\nabla})\bar{G}(\vec{x}, \vec{x}', s) = -\delta^3(\vec{x} - \vec{x}') \quad (28)$$

where V is the entire volume between the electrodes. As in the last section we use Green's theorem (21), replace ϕ with $\bar{\Phi}(\vec{x}, s)$, $f(\vec{x})$ with $\epsilon(\vec{x}, s)$ and can still chose ψ arbitrarily. If we again chose ψ to be the potential function of the geometry in Fig. 4 where the charge density is removed i.e.

$$\vec{\nabla}(\epsilon(\vec{x}, s)\vec{\nabla})\bar{\psi}_V(\vec{x}, s) = 0 \quad \bar{v}_i(s) = \bar{\psi}(\vec{x}, s)_V|_{\vec{x}=S_i} \quad (29)$$

with still arbitrary boundary conditions $\bar{v}_i(s)$ we find

$$\int_V \bar{\psi}_V(\vec{x}', s)\bar{\rho}(\vec{x}', s)d^3x' = \sum_i \bar{v}_i(s)[\bar{Q}_i(s) + \frac{1}{s}\bar{I}_i(s)] - \sum_i \bar{V}_i(s)[\bar{q}_i(s) + \frac{1}{s}\bar{i}_i(s)] \quad (30)$$

Since the electrodes in Fig. 4a are not connected to to any external source we have $I_i^{ext} = 0$. Multiplying both sides with s and using Equations 19, and 20 we find

$$\int_V s\bar{\psi}_V(\vec{x}', s)\bar{\rho}_e(\vec{x}', s)d^3x' = \sum_i \bar{V}_i(s)i_i^{ext} \quad (31)$$

If we chose the boundary conditions for $\bar{\psi}$ such that $i_i^{ext} = 0$ for $i \neq 1$ and $i_1^{ext} = q_0 = \text{const.}$, which means in the time domain that we define ψ by putting a current delta pulse $q_0\delta(t)$ on electrode 1 while leaving all other electrodes unconnected, we have

$$\bar{V}_1(s) = \frac{1}{q_0} \int_V s\bar{\psi}_V(\vec{x}', s)\bar{\rho}_e(\vec{x}', s)d^3x' \quad (32)$$

and in the time domain we get

$$V_1(t) = \frac{1}{q_0} \int_0^t \int_V \psi_V(\vec{x}', t-t') \frac{\partial \rho_e(\vec{x}', t')}{\partial t'} d^3x' dt' \quad (33)$$

This is the desired theorem:

The voltage induced by a time dependent charge distribution on an electrode embedded in a medium of permittivity $\varepsilon(\vec{x}, s)$ and conductivity $\sigma(\vec{x}, s)$ can be calculated the following way: we remove the charge, apply a delta current $q_0\delta(t)$ on the electrode in question which defines a time dependent potential $\psi_V(\vec{x}, t)$ in the space between the electrodes from which $V(t)$ can be calculated with Equation 33. We call ψ_V the 'weighting potential'.

If σ is zero i.e. the electrodes are insulated, the fields are instantaneous, the time dependence of ψ becomes $\psi(\vec{x}, t) = \psi(\vec{x})\Theta(t)$ and the above theorem reads as

$$V_1(t) = \frac{1}{q_0} \int_V \psi_V(\vec{x}')\rho_e(\vec{x}')d^3x' \quad (34)$$

If the electrodes are grounded (Figure 4b), the voltages $V_i(t)$ are zero and the time dependent charge density induces currents $\bar{I}_i^{ext}(t) = I_i^G(t)$ flowing between the electrodes and ground. We therefore have the relation

$$\frac{d}{dt}Q_i(t) + I^i(t) = I_i^G(t) \quad \rightarrow \quad s\bar{Q}_i(s) + \bar{I}_i(s) = \bar{I}_i^G(s) \quad (35)$$

and equation 30 becomes

$$\int_V s\bar{\psi}_I(\vec{x}', s)\bar{\rho}_e(\vec{x}', s)d^3x' = \sum_i \bar{v}_i(s)I_i^G(s) \quad (36)$$

We see that defining ψ by putting the voltage pulse $v_1(t) = v_0\delta(t) \rightarrow \bar{v}_1(s) = v_0$ on electrode 1 while keeping all others grounded we find the induced current on the electrode by the relation

$$I_1^G(t) = \frac{1}{v_0} \int_0^t \int_V \psi_I(\vec{x}', t-t') \frac{\partial \rho_e(\vec{x}', t')}{\partial t'} d^3x' dt' \quad (37)$$

which is the second desired theorem:

The current induced by a time dependent charge distribution on a grounded electrode embedded in a medium of permittivity $\varepsilon(\vec{x}, s)$ and conductivity $\sigma(\vec{x}, s)$ can be calculated the following way: we remove the charge, apply a delta voltage pulse $v_0\delta(t)$ on the electrode in question which defines a time dependent potential $\psi_I(x, t)$ in the space between the electrodes from which $I^G(t)$ can be calculated with Equation 37.

Since the above theorems hold for general $\sigma(\vec{x}, s)$ and $\varepsilon(\vec{x}, s)$ they are also valid if they are connected with arbitrary networks as shown in Fig. 1 since we can imagine the $Y_{ij} = 1/Z_{ij}$ to be contained in σ and ε .

If σ is zero the time dependence of ψ becomes $\psi(\vec{x}, t) = \psi(\vec{x})\delta(t)$ and the theorem reads as

$$I_1^G(t) = \frac{1}{v_0} \int_V \psi_I(\vec{x}') \frac{\partial \rho_e(x', t)}{\partial t} d^3x' \quad (38)$$

With $\vec{\nabla} j_e = -\partial \rho_e / \partial t$ we find

$$I_1^G(t) = \frac{1}{v_0} \int_V \vec{E}_I(\vec{x}') \vec{j}_e(\vec{x}, t) d^3x' \quad \vec{E}_I(\vec{x}) = -\vec{\nabla} \psi_I(\vec{x}) \quad (39)$$

which recuperates Ramo's theorem.

4.1 Signals induced by a moving Point Charge

The charge density of a point charge Q created at $t = 0$ and moving along a trajectory $\vec{x}(t)$ is given by

$$\rho_e(\vec{x}, t) = Q\Theta(t)\delta^3[\vec{x} - \vec{x}_0(t)] \quad (40)$$

Inserting this in the above formula we find

$$V_1(t) = \frac{Q}{q_0} \psi_V(\vec{x}_0(t), t) + \frac{Q}{q_0} \int_0^t \vec{E}_V(\vec{x}_0(t'), t - t') \vec{x}_0(t') dt' \quad \vec{E}_V(\vec{x}, t) = -\vec{\nabla} \psi_V(\vec{x}, t) \quad (41)$$

The first term is due to the creation of the charge and the second term is due to the movement of the charge. In an detector the charge is always created through ionization i.e. an electron and an ion are produced at the same place from where they move in opposite directions along trajectories $\vec{x}_1(t)$ and $\vec{x}_2(t)$. In that case the charge density is given by

$$\rho_e(\vec{x}, t) = \Theta(t) [Q\delta^3(\vec{x} - \vec{x}_1(t)) - Q\delta^3(\vec{x} - \vec{x}_2(t))] \quad \text{where} \quad \vec{x}_1(0) = \vec{x}_2(0) \quad (42)$$

The induced voltage then becomes

$$V_1(t) = \frac{Q}{q_0} \int_0^t \vec{E}_V(\vec{x}_1(t'), t - t') \vec{x}_1(t') dt' + \frac{Q}{q_0} \int_0^t \vec{E}_V(\vec{x}_2(t'), t - t') \vec{x}_2(t') dt' \quad (43)$$

so the term due to the creation of the charge cancels and the signal can be calculated by the weighting field $\vec{E}_V(\vec{x}, t)$. The induced signal is only due to the *movement* of the charges. The same relation is of course true for the induced current:

$$I_1(t) = \frac{Q}{v_0} \int_0^t \vec{E}_I(\vec{x}_1(t'), t-t') \vec{x}_1(t') dt' + \frac{Q}{v_0} \int_0^t \vec{E}_I(\vec{x}_2(t'), t-t') \vec{x}_2(t') dt' \quad (44)$$

4.2 Connection between Induced Current and Voltage

Finally we want to find the connection between the voltage induced on the electrodes and the currents induced on the electrodes in case they are grounded. Arguing in the s -domain, the weighting potential for the induced voltage on electrode 1, $\bar{\psi}_V(\vec{x}, s)$, is defined by a current pulse q_0 on the electrode 1. This current pulse will create voltage signals

$$\bar{v}_i(s) = Z_{1i}(s) q_0 \quad (45)$$

on all the electrodes, where Z_{ij} is the impedance matrix defined earlier. A current pulse q_0 on electrode 1 is therefore equal to voltage pulses $\bar{v}_i(s)$ on the electrodes. The corresponding potential $\bar{\psi}_V$ for this boundary condition $\bar{v}_i(s)$ is given by

$$\bar{\psi}_V(\vec{x}, s) = \sum_i \bar{v}_i(s) \frac{1}{v_0} \bar{\psi}_i(\vec{x}, s) = q_0 \sum_i Z_{1i}(s) \frac{1}{v_0} \bar{\psi}_i(\vec{x}, s) \quad (46)$$

where $\bar{\psi}_i(\vec{x}, s)$ are the potentials when electrode i is put to voltage v_0 and all others are grounded. This however is the definition of the weighting potentials for the current induced on the grounded electrodes. Therefore we have the following connection:

The voltages induced by a time dependent charge distribution on electrodes embedded in a medium of permittivity $\varepsilon(\vec{x}, s)$ and conductivity $\sigma(\vec{x}, s)$ are connected with the currents induced by the same charge distribution on the grounded electrodes are connected with the characteristic impedance matrix $Z_{ij}(s)$ through

$$\bar{V}_i(s) = \sum_j Z_{ij} \bar{I}_j^G(s) \quad (47)$$

This is a very useful result since usually ψ_I and therefore I^G are easy to calculate from electrostatic solutions, and once we know ψ_I for all electrodes we also know Z_{ij} as seen from the definition 26. We will show an example later.

5 RPC with Infinite Plane Electrode

To illustrate the formalism we first study the signal induced on an infinite plane electrode in an RPC like detector geometry. After that we look at the signal induced on a strip electrode. In these examples we calculate the induced current on a grounded electrode. The induced voltage on an electrode connected to an amplifier will be treated later. We will assume that an electron and an ion are produced in one point, the electron is moving with velocity v and the ion does not move.

5.1 Resistive Layer touching the Plane Electrode

First we apply the formalism to the geometry shown in Figure 5. A point charge Q is moving between two resistive layers and we want to know the induced current on electrode 1.

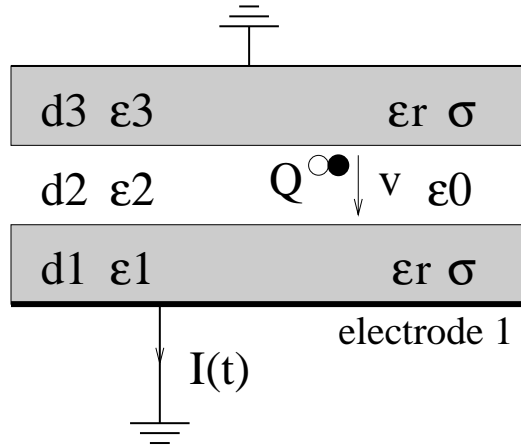

Figure 5: Resistive Plate Chamber. The charge moving in the gas gap induces a current $I(t)$ on the electrode. The finite resistivity of the plates affects the signal.

The electrostatic weighting field of electrode 1 i.e. the electric field in the gap in case electrode 1 is put to voltage v_0 is given by

$$E_z = \frac{v_0 \varepsilon_1 \varepsilon_3}{\varepsilon_2 \varepsilon_3 d_1 + \varepsilon_1 \varepsilon_3 d_2 + \varepsilon_1 \varepsilon_2 d_3} \quad (48)$$

By applying the statements from section 2 we derive the time dependent weighting field i.e. the electric field in the gap for a voltage pulse $v_0 \delta(t)$ by replacing $\varepsilon_1, \varepsilon_3 \rightarrow \varepsilon_0 \varepsilon_r + \sigma/s$, $\varepsilon_2 \rightarrow \varepsilon_0$ which gives

$$E_z(s) = \frac{v_0 (\sigma + \varepsilon_r \varepsilon_0 s)}{(d_1 + d_2 \varepsilon_r + d_3) \varepsilon_0 s + \sigma d_2} \quad (49)$$

In the limit of very small and very large conductivity we find

$$\lim_{\sigma \rightarrow 0} E_z(s) = \frac{v_0 \varepsilon_r}{d_1 + d_2 \varepsilon_r + d_3} \quad \lim_{\sigma \rightarrow \infty} E_z(s) = \frac{v_0}{d_2} \quad (50)$$

For small conductivity the weighting field is just the electrostatic one. For large conductivity the resistive layers can be viewed as part of the electrodes and the RPC is equal to an empty

condenser with plate separation d_2 . For finite conductivity σ the time dependent weighting field is found by inverse Laplace transform of the above expression which gives

$$E_z(t) = v_0 \left(\frac{\varepsilon_r}{d_1 + d_2\varepsilon_r + d_3} \delta(t) + \frac{\sigma}{\varepsilon_0} \frac{d_1 + d_3}{(d_1 + d_2\varepsilon_r + d_3)^2} e^{-\frac{t}{\tau}} \right) \quad \tau = \frac{\varepsilon_0 (d_1 + d_3\varepsilon_r + d_3)}{\sigma d_2} \quad (51)$$

Using Eq. 44, the current induced by a charge Q created on the edge of the gas gap at $t = 0$ and moving with a constant velocity v through the gap d_2 until it hits the resistive layer at $T = d_2/v$ is

$$I(t) = \frac{Q}{v_0} \int_0^t E_z(t - t') v dt' \quad (52)$$

which gives

$$\begin{aligned} \frac{I(t)}{Qv} &= \frac{1}{d_1 + d_2\varepsilon_r + d_3} \left[\varepsilon_r + \frac{d_1 + d_3}{d_2} (1 - e^{-\frac{t}{\tau}}) \right] \quad t < T \\ &= \frac{1}{d_1 + d_2\varepsilon_r + d_2} \frac{d_1 + d_3}{d_2} (e^{\frac{T}{\tau}} - 1) e^{-\frac{t}{\tau}} \quad t > T \end{aligned} \quad (53)$$

The result is shown in Fig. 6. For $\tau \gg T$ the resistive plates act like insulators and the signal is not affected by the conductivity. For $\tau \ll T$ the resistive plates act like perfect conductors and the detector looks like an empty capacitor with gap d_2 . The total induced charge is $\int I(t) dt = Q$ independent of the conductivity of the resistive plates. The 'current tail' for $t > T$ is due to the 'annihilation' of the charge sitting on the surface of the resistive plate which was pointed out in section 2.2.

In Trigger RPCs [8], typical values are $T \approx 20$ ns and $1/\sigma \approx 10^{10} \Omega cm$. Therefore $\tau = \varepsilon_0/\sigma \approx 10^{-3}$ s which is much larger than T , so the conductivity of the resistive plates has no influence whatsoever on a single RPC signal. For timing RPCs [9] typical values are $T \approx 1$ ns and $1/\sigma \approx 10^{12} \Omega cm$, so the effects is even smaller. We can conclude that in 'standard' RPCs the resistive plates affect the signal only through their dielectric constant.

5.2 Resistive Plate between Gas Gap and Plane Electrode

Next we look at the geometry shown in Figure 7. The gap where the charge is moving is separated from the electrode through a resistive plate. The electrostatic weighting field in the gap is now given by

$$E_z = \frac{v_0 \varepsilon_1 \varepsilon_2}{\varepsilon_2 \varepsilon_3 d_1 + \varepsilon_1 \varepsilon_3 d_2 + \varepsilon_1 \varepsilon_2 d_3} \quad (54)$$

If the resistive layer 1 has a permittivity ε_r and layer 2 the conductivity σ we replace $\varepsilon_1 \rightarrow \varepsilon_r \varepsilon_0$, $\varepsilon_2 \rightarrow \varepsilon_0 + \sigma/s$ and $\varepsilon_3 \rightarrow \varepsilon_0$ and we find

$$E_z(s) = \frac{v_0 (\varepsilon_r \sigma + \varepsilon_0 s)}{[d_1 + (d_2 + d_3) \varepsilon_r] \varepsilon_0 s + \sigma (d_1 + \varepsilon_r d_3)} \quad (55)$$

In the limit if very small and very large conductivity we find

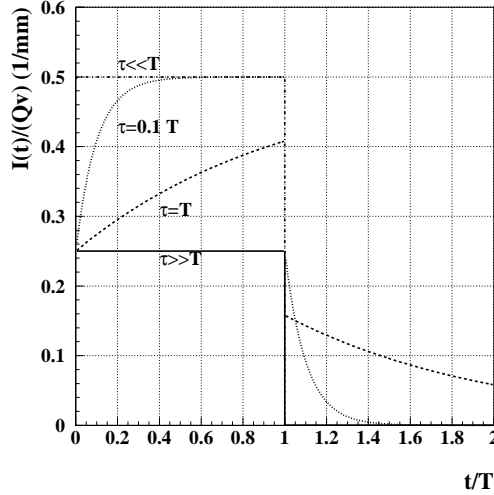

Figure 6: Current induced on the electrode from Figure 5. If $\tau \approx T$ the signal shows an exponential time dependence. For $T \gg \tau$ and $T \ll \tau$ the signals are equal to the electrostatic case.

$$\lim_{\sigma \rightarrow 0} E_z(s) = \frac{v_0}{d_1 + (d_2 + d_3)\varepsilon_r} \quad \lim_{\sigma \rightarrow \infty} E_z(s) = \frac{v_0\varepsilon_r}{d_1 + \varepsilon_r d_3} \quad (56)$$

We find that even for perfect conductivity of the resistive layer the movement of the charge induces a signal on the electrode. At first sight this seems counter-intuitive since we expect a perfect conductor to shield the signal from the electrode. However this is only true if the conductor is grounded. If it is however floating (like in our assumption) a positive charge Q induces a negative charge on the top surface. This will result in a positive charge on the down side of the plate which in turn induces a negative charge on the electrode which explains why a floating electrode is 'transparent'.

The time dependent weighting field for finite conductivity has the same form as the one in Equation 51 with different time constants so the induced signals have the same shape as shown in Fig. 6.

5.3 Resistive Layer on Dielectric Insulator and Plane Electrode

Now we turn layer 2 into an infinitely thin layer with a given surface resistivity R . We use Eq. 55 replace σ with $1/(d_2 R)$ and set $d_2 \rightarrow 0$ which gives

$$E_z(s) = \frac{v_0\varepsilon_r}{d_1 + \varepsilon_r d_3} \quad (57)$$

which means that a thin floating layer with whatever surface resistivity R has no influence on the current induced on the electrode and the weighting field is the same as the one for a geometry without layer 2 ! All these conclusions are only valid for an infinite plane electrode. The next section which treats strip electrodes will clarify this picture.

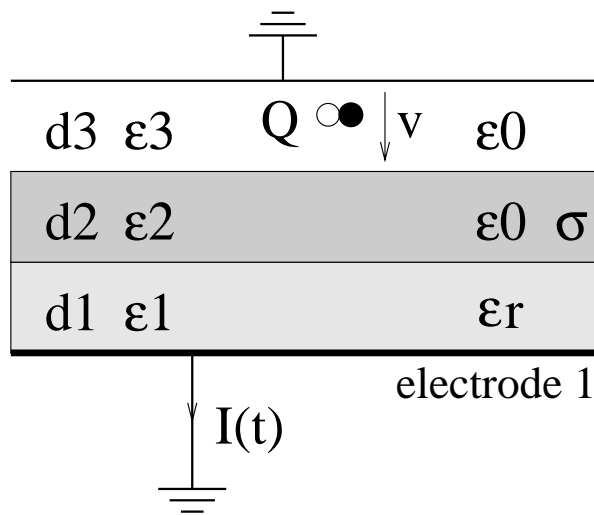

Figure 7: Detector where the gas gap is separated from the electrode by a resistive layer.

6 Strip Electrode

To study the signals induced on a strip electrode in presence of conducting material we start with the electrostatic weighting field for the geometry shown in Figure 8.

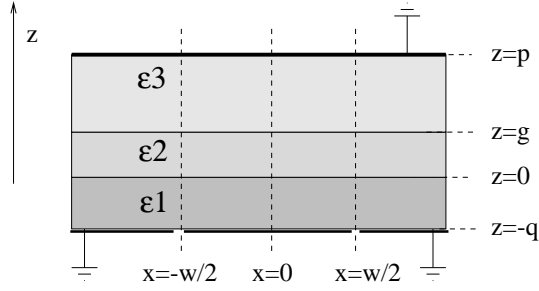

Figure 8: Geometry with a strip electrode of width w and three layers of different permittivities.

The z -component of the electric field in layer 2 and 3 when applying the potential v_0 to the strip electrode of width w is given by [6]

$$E_z^i(x, z) = \frac{4v_0}{\pi} \int_0^\infty d\kappa \cos(\kappa x) \sin\left(\kappa \frac{w}{2}\right) F_i(\kappa, z) \quad (58)$$

with

$$F_2(\kappa, z) = \frac{\varepsilon_1(\varepsilon_2 + \varepsilon_3) \cosh[\kappa(p - z)] - \varepsilon_1(\varepsilon_2 - \varepsilon_3) \cosh[\kappa(p + z - 2g)]}{D(\kappa)} \quad (59)$$

$$F_3(\kappa, z) = \frac{2\varepsilon_1\varepsilon_2 \cosh[\kappa(p - z)]}{D(\kappa)} \quad (60)$$

$$\begin{aligned} D(\kappa) = & (\varepsilon_1 + \varepsilon_2)(\varepsilon_2 + \varepsilon_3) \sinh[\kappa(p + q)] \\ & - (\varepsilon_1 - \varepsilon_2)(\varepsilon_2 + \varepsilon_3) \sinh[\kappa(q - p)] \\ & - (\varepsilon_1 + \varepsilon_2)(\varepsilon_2 - \varepsilon_3) \sinh[\kappa(2g + q - p)] \\ & + (\varepsilon_1 - \varepsilon_2)(\varepsilon_2 - \varepsilon_3) \sinh[\kappa(p + q - 2g)] \end{aligned}$$

For $x = 0, w \rightarrow \infty$ the expressions transform into

$$E_z^2(x, z) = \frac{v_0\varepsilon_1\varepsilon_3}{\varepsilon_2\varepsilon_3q + \varepsilon_1\varepsilon_3g + \varepsilon_1\varepsilon_2(p - g)} \quad E_z^3(x, z) = \frac{v_0\varepsilon_1\varepsilon_2}{\varepsilon_2\varepsilon_3q + \varepsilon_1\varepsilon_3g + \varepsilon_1\varepsilon_2(p - g)} \quad (61)$$

which recuperates the expressions 48 and 54 for the infinite plane electrode. The time dependent weighting field in case the layers have conductivities $\sigma_1, \sigma_2, \sigma_3$ can again be calculated by replacing ε_i with $\varepsilon_i + \sigma_i/s$ and performing the inverse Laplace transform. We will only show a qualitative discussion of the geometries with resistive plates and a careful quantitative discussion of the effect of the thin resistive layer.

6.1 Resistive Layer touching the Strip Electrode

First we study the geometry from section 5.1 for a strip electrode. Layer 1 and 3 have conductivity σ and layer 2 is the gas gap where the charge is moving. We use $F_2(\kappa, z)$ and replace $\varepsilon_1, \varepsilon_3 \rightarrow \varepsilon_0 \varepsilon_r + \sigma/s, \varepsilon_2 \rightarrow \varepsilon_0$. For infinite conductivity of the resistive plates we find

$$\lim_{\sigma \rightarrow \infty} F_2(\kappa, z) = \frac{v_0 \cosh[\kappa(g-z)]}{2 \sinh(\kappa g) \cosh(\kappa q)} \quad (62)$$

so E_z^2 stays finite and we still find a signal on the strip. This is intuitively clear since the bottom plate is in direct contact with the strips and the charge induced on the plate is flowing from the strips onto the resistive plate.

6.2 Resistive Plate between Gas Gap and Strip Electrode

To study the geometry from section 5.2 where the gas gap and the readout electrode are separated by a resistive and an insulating layer we use $F_3(\kappa, z)$ and replace $\varepsilon_1 \rightarrow \varepsilon_0 \varepsilon_r, \varepsilon_2 \rightarrow \varepsilon_0 + \sigma/s, \varepsilon_3 \rightarrow \varepsilon_0$. For infinite conductivity of the resistive layer we find

$$\lim_{\sigma \rightarrow \infty} F_3(\kappa, z) = 0 \quad (63)$$

so the layer 'shields' the signal from the strip. From section 5.2 we know that the signal induced on an infinite plane electrode is *not* shielded by the conducting layer, so if we imagine many strips next to each other we know that the sum of the signals on all strips is given by 55. From this we see that the resistive plate will cause crosstalk to the other strips and the lower the resistivity the more strips will show a signal and the smaller the signal on the individual strips will be. For common RPCs the plate resistivity is so high that there is no effect on the induced signal. However, in some RPCs the voltage is supplied to the resistive plate through a thin carbon layer with surface resistivity between 10^5 and 10^6 k Ω which can have an effect on the signal as shown in the next section.

6.3 Resistive Layer on Dielectric Insulator and Strip Electrode

Now layer 1 should represent an insulating dielectric with relative dielectric constant ε_r , layer 2 should represent an infinitely thin resistive layer with a given surface resistivity of R and layer 3 is the gas gap. We use $F_3(\kappa, z)$ and set $\sigma = 1/(gR)$, replace $\varepsilon_1 \rightarrow \varepsilon_0 \varepsilon_r, \varepsilon_2 \rightarrow \varepsilon_0 + \sigma/s, \varepsilon_3 \rightarrow \varepsilon_0$, take the limit $g \rightarrow 0$ and we find the expression

$$F_3(\kappa, z) = \frac{1}{2} \frac{s \varepsilon_0 R \varepsilon_r \cosh[\kappa(p-z)]}{\kappa \sinh(\kappa p) \sinh(\kappa q) + s \varepsilon_0 R [(\varepsilon_r - 1) \cosh(\kappa q) \sinh(\kappa p) + \sinh[\kappa(p+q)]]} \quad (64)$$

which we can write as

$$F_3(k, z) = b(k, z) \frac{sRC(\kappa)}{1 + sRC(\kappa)} \quad (65)$$

This is equal to the transfer function of a differentiating RC element. In the previous section we saw that the total signal induced on the infinite electrode is not affected by the resistance R and is equal to the electrostatic case. The signal on the strip with finite width is however differentiated and therefore we expect also signals on the neighbouring strips such that all of

them add up to the signal given before. So for decreasing resistance we expect increasing signal differentiation on the central strip and increasing crosstalk to all other strips. Performing the inverse Laplace transform we find the expression for the time dependent weighting field:

$$E_z(x, z, t) = \frac{4v_0}{\pi} \int_0^\infty d\kappa \cos(\kappa x) \sin\left(\kappa \frac{w}{2}\right) \left[f_1(\kappa, z) \delta(t) - \frac{f_2(\kappa, z)}{\tau} \exp\left(-\frac{t}{\tau} f_3(\kappa)\right) \right] \quad (66)$$

with $\tau = R\varepsilon_0(p + q)$ and

$$f_1(\kappa, z) = \frac{1}{2} \frac{\varepsilon_r \cosh[\kappa(p - z)]}{\sinh[\kappa(p + q)] + (\varepsilon_r - 1) \sinh(\kappa p) \cosh(\kappa q)} \quad (67)$$

$$f_2(\kappa, z) = \frac{\kappa(p + q)}{2} \frac{\varepsilon_r \sinh(\kappa p) \sinh(\kappa q) \cosh[\kappa(p - z)]}{\sinh[\kappa(p + q)] + (\varepsilon_r - 1) \sinh(\kappa p) \cosh(\kappa q)} \quad (68)$$

$$f_3(\kappa) = \frac{\kappa(p + q) \sinh(\kappa p) \sinh(\kappa q)}{\sinh[\kappa(p + q)] + (\varepsilon_r - 1) \sinh(\kappa p) \cosh(\kappa q)} \quad (69)$$

where f_1, f_2, f_3 are dimensionless functions. The signal induced by a point charge Q moving along z is then given by

$$I(t) = \frac{Q}{v_0} \int_0^t E_z(x, z(t'), t - t') \dot{z}(t') dt' \quad (70)$$

In particle detectors one usually has an electron avalanche that induces the signal and since the avalanche grows exponentially, the largest part of the induced signal is due the very end of the avalanche development. For our calculation this means that we are interested only in a very small z range of the weighting field where we can assume it to be constant. Assuming now that the charge is moving with a velocity v between time $0 < t < T$ 'around' position z_0 we can perform the integration and (after changing the integration variable to $r = (p + q)\kappa$) we find for $t < T$:

$$\frac{I(t, z_0)}{Qv} = \frac{8}{\pi} \int_0^\infty \frac{dr}{p+q} \cos\left(r \frac{x}{p+q}\right) \sin\left(r \frac{w}{2(p+q)}\right) f_1\left(\frac{r}{p+q}, z_0\right) \exp\left(-\frac{t}{\tau} f_3\left(\frac{r}{p+q}, z_0\right)\right) \quad (71)$$

and for $t > T$:

$$\begin{aligned} \frac{I(t, z_0)}{Qv} = & -\frac{8}{\pi} \int_0^\infty \frac{dr}{p+q} \cos\left(r \frac{x}{p+q}\right) \sin\left(r \frac{w}{2(p+q)}\right) f_1\left(\frac{r}{p+q}, z_0\right) \left[\exp\left(\frac{T}{\tau} f_3\left(\frac{r}{p+q}, z_0\right)\right) - 1 \right] \times \\ & \exp\left(-\frac{t}{\tau} f_3\left(\frac{r}{p+q}, z_0\right)\right) \end{aligned} \quad (72)$$

Figure 9 shows examples of signals for different resistivities R . For decreasing resistance R (decreasing τ) the signal on the central strip is more and more differentiated and the crosstalk to the first neighbour increases. Decreasing the resistance even more will cause a differentiated signal also on the first neighbour and will start crosstalk to the 2nd neighbour etc.

For a surface resistivity of $100 \text{ k}\Omega$ and $p = q = 2 \text{ mm}$ we have $\tau = 3.5 \text{ ns}$ which is comparable to $T = 20 \text{ ns}$ in Trigger RPCs, so we can conclude that resistivities around $10^5 \Omega$ of the layers supplying the voltage to resistive plates in RPCs with gap and plate dimensions of a few mm have an effect on the induced signals.

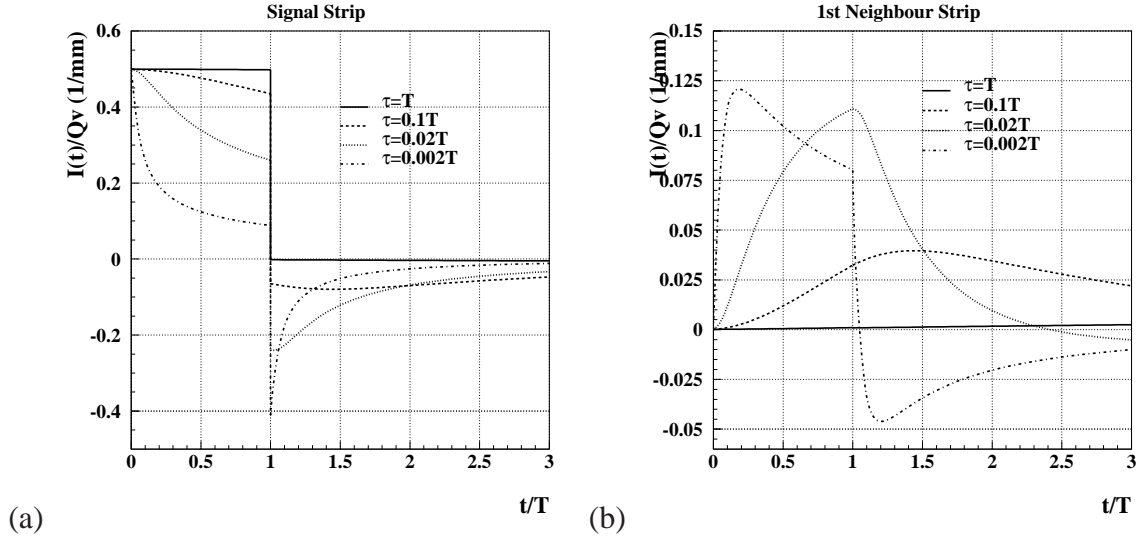

Figure 9: Signal induced by a charge Q moving at $x = 0$ along z with velocity v between $t = 0$ and $t = T$ for the geometry shown in Fig. 8. The distances p and q are 2 mm, the strip width is $w = 10 \text{ mm}$. (a) shows the signal induced on the central strip and (b) shows the signal induced on a neighbour strip of same width. For decreasing values of $\tau = R\varepsilon_0(p + q)$ the signal on the central strip is differentiated and the crosstalk to the neighbours increases.

7 Induced Voltage

Now we want to find the *voltage* induced in the detector shown in Figure 5 in case the electrode is connected to ground through a general impedance network $Z_A(s)$ (Figure 10).

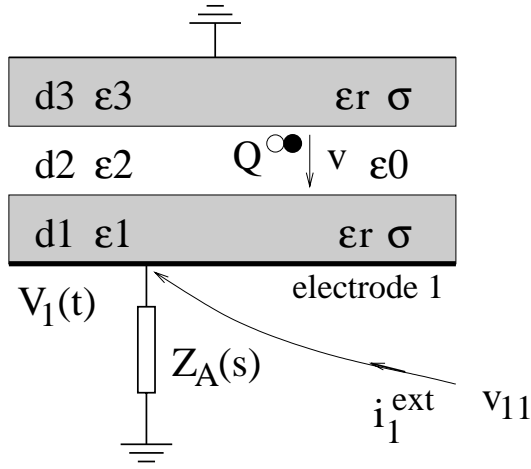

Figure 10: RPC geometry where the readout electrode is connected to an amplifier element.

As described in the introduction we consider this impedance to be 'part of the medium'. As shown in section 4.2 this voltage is connected with the current induced on the grounded electrode through

$$V_1(s) = Z_{11}(s)I_1(s) \quad (73)$$

where $I_1(s)$ was already calculated in section 5.1 and is given by Eq. 53. To find Z_{11} we need the current i_1^{ext} flowing onto the electrode for a voltage delta pulse v_{11} on the electrode. The electric field on the electrode surface is

$$E_1 = \frac{v_{11}\epsilon_0}{(d_1 + d_3)\epsilon_0 + d_2(\epsilon_0\epsilon_r + \sigma/s)} \quad (74)$$

and therefore the charge on the electrode surface is

$$q_1(s) = \epsilon_r\epsilon_0 E_1 A \quad (75)$$

where A is the electrode area. The current leaving the surface of the electrode is

$$i_1(s) = \sigma E_1 + \frac{v_{11}}{Z_A(s)} \quad (76)$$

With $i_1^{ext} = sq(s) + i_1(s)$ and $Z_{11} = v_{11}/i_1^{ext}$ we have

$$Z_{11} = \frac{Z_A(s)Z_D(s)}{Z_A(s) + Z_D(s)} \quad (77)$$

where the detector impedance $Z_D(s)$ is given by

$$Z_D(s) = \frac{d_1 + \varepsilon_r d_2 + d_3}{A(s\varepsilon_0\varepsilon_r + \sigma)} + \frac{d_2\sigma}{s\varepsilon_0A(s\varepsilon_0\varepsilon_r + \sigma)} \quad (78)$$

In case σ is zero the detector impedance becomes

$$Z_D(s) = \frac{1}{sC_D} \quad C_D = \frac{A\varepsilon_0\varepsilon_r}{(d_1 + \varepsilon_r d_2 + d_3)} \quad (79)$$

where C_D is the detector capacitance. The equivalent circuit is shown in Figure 11. Applying the current signal derived in section 5 to this equivalent circuit gives the voltage induced on the electrode.

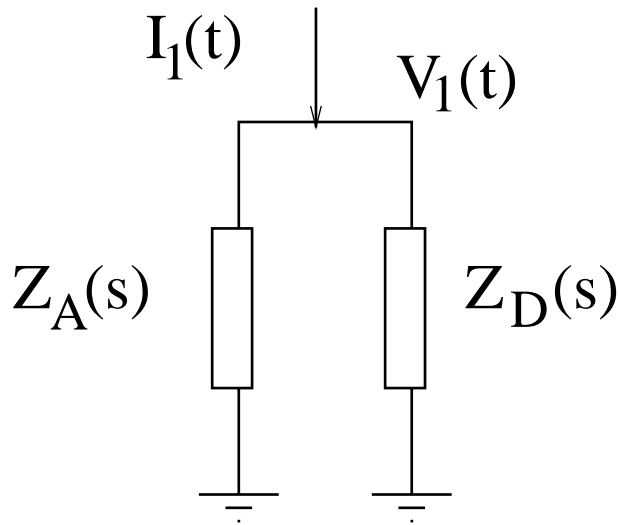

Figure 11: Equivalent circuit to calculate the induced voltage from the current induced on a grounded electrode.

8 Conclusions

We have investigated the signals induced on electrodes embedded in a conducting environment by using the quasi-static approximation of Maxwell's equations. The signals can be calculated by time dependent weighting fields as also shown in [3]. If the electrostatic solution of the weighting field for an insulating medium with given $\varepsilon_1(\vec{x})$ is known, the time dependent weighting field for a medium with conductivity $\sigma(\vec{x}, s)$ and permittivity $\varepsilon(\vec{x}, s)$ is given by replacing $\varepsilon_1(\vec{x})$ with $\varepsilon(\vec{x}, s) + \sigma(\vec{x}, s)/s$ and performing the inverse Laplace transform.

As examples we treated RPC like geometries, in particular we studied the effect of a thin resistive layer on the signal induced on a strip electrode. We conclude that decreasing surface resistivity of this layer introduces signal differentiation on the central strip and crosstalk to the neighbour strips.

The resistivity of the materials used in 'standard' RPCs results in time constant that are a few orders of magnitude larger than the duration of the charge movement in the detector and has therefore negligible influence on the signal. The thin carbon layers used for HV contact in RPCs with surface resistivities of 0.1-1 M Ω however result in time constants that are comparable to the charge movement duration and were therefore studied carefully in this report.

We would like to thank Martin Aleksa and Christian Lippmann for important discussions and suggestions.

References

- [1] H.A. Haus, J.R. Melcher, Electromagnetic fields and energy, Prentice Hall Inc., Englewood Cliffs, NJ, 1989.
- [2] T. Heubrandtner, B. Schnizer, The Quasi-Static Electromagnetic Approximation for Weakly Conducting Media, NIMA, EXT-2001-020 ; Univ. Graz , 20 Mar 2001
- [3] E. Gatti, G. Padovini and V. Radeka, Signal evaluation in multielectrode radiation detectors by means of a time dependent weighting vector, NIM 193 (1982) 651-653
- [4] S. Ramo, Currents induced in electron motion, PROC. IRE 27, 584 (1939)
- [5] W. Blum, L. Rolandi: Particle Detection with Drift Chambers. Springer Verlag 1994.
- [6] Static electric fields in an infinite plane condensor with one or three homogeneous layers / Heubrandtner, T ; Schnizer, B ; Lippmann, C ; Riegler, W ; CERN-OPEN-2001-074 ; Geneva : CERN , 31 Oct 2001. - 26 p.
- [7] J.D. Jackson, Classic Electrodynamics, Wiley, New York, 1975
- [8] R. Santonico et al., Development of Resistive Plate Counters, NIM A263 (1981) et. al.
- [9] P. Fonte et. al, High-resolution RPCs for large TOF systems, NIM A449 (2000) 295-301