

# THE IMPROVEMENT OF THE BEAM DIAGNOSTIC SYSTEM FOR HIRFL

Chu Zhensheng Song Haihong XU Xiangyang  
The Institute of Modern Physics, Chinese Academy of Sciences  
P.O. Box 31, Lanzhou 730000,China

## 1 INTRODUCTION

The Beam Diagnostic System plays an important role in beam tuning and quality-updating of the HIRFL machine since its beginning in 1988. Many improvements have been made according to the operation requirement of HIRFL. Some of the improvements of the diagnostic system on the beam lines of HIRFL have been reported at the previous ICALEPCS'97 conference, by our colleague Zheng Jianhua (see the proceedings of ICALEPCS97, P605-607). This paper will describe more improvements made on the diagnostic system of the SFC and SSC of HIRFL.

## 2 IMPROVEMENT OF THE RADIAL PROBE CONTROL

Due to the design approach, the velocity of the movement of radial probes inside the accelerator (SFC and SSC) where too slow, and their performances where not very reliable. For this reason, the controllers of the radial probes had to be updated. The controls and timing circuits have been modified, by changing the code of Gray to BCD and converted to serial Gray-Binary-BCD mode, to parallel Gray-BCD, by using a code stored in EPROM.

After the modification, the circuits are more simplified and more reliable. The travelling time of the radial probes in the SSC for 2.5m is only 2.5 minutes instead of 10 minutes. For convenience of beam tuning and maintenance, the function of program control for the moving velocity of radial probes is added.

The performance of the new radial probe controllers is satisfactory, and has been used at the radial probes of the SSC and SFC of HIRFL.

## 3 IMPROVEMENT OF IVC FOR BEAM MEASUREMENT

IVC is an abbreviation of "Current to voltage Converter".

After years of observing and testing, we found there is a serious interference collected by the outer wire connecting to the mobile targets or fixed targets, caused 50 Hz frequency pick up. The basic noise  $V_{p-p}$  was higher than  $\pm 5V$ . We averaged the values of multi-measurement (usually by 250-1500 times) in order to smooth down the

noise. Even so, processed data still fluctuated. Considering the requirement of response-time of the beams detected in mobile probes, the filter can not be made of condensers and resistors. We employed a filter of 50 Hz and obtained a 40dB reduction, and a response-time of 28ms. The IVCs with the filter meets the requirement of the beam measurement.

The updated IVCs with a sensitivity of 20nA (which can easily be altered to larger ranges) and a resolution better than 1% has been used on, 9 differential targets of 3 radial probes in SSC. They work well during one-year of operation.

Further improved multi-range IVCs have been completed and tested. The new specifications are: (1) three ranges of 10nA, 1 $\mu$ A, and 5 $\mu$ A; (2) initially a maximum range of 5 $\mu$ A to avoid overloading the IVC when it is turned on; (3) a programmable offset control circuit with a digital potentiometer is used to correct instantly the zero shift caused by temperature change. The circuit of the multi-range IVC is shown at Fig.1.

## 4 IMPROVEMENT OF THE SYSTEM PERFORMANCE

Based on the improvements presented above, the running programs were rewritten with the language of Borland C++ 5.0 on Windows 95, which were more convenient and intuitive. The unstopped measurements of beams along the directions of radial and axis were realized in SSC. It takes 4 minutes instead of 52 minutes including stop measurements as before. The obtained results of the radial probes in the SFC is satisfactory and agrees to the parameters of the SFC accelerator.

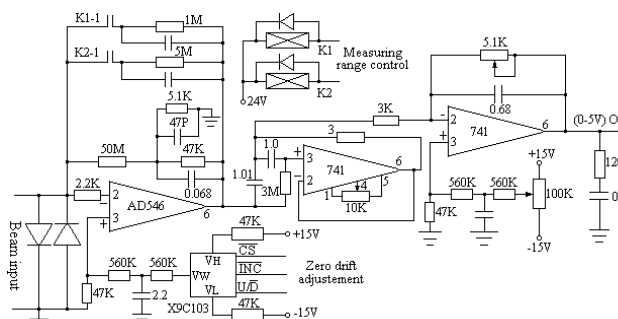

Figure 1: Basic circuit of IVC with 50Hz filter