

Electronics for Calorimeters at LHC

Veljko Radeka

Brookhaven National Laboratory, Upton, NY 11973-5000
radeka@bnl.gov

Abstract

Some principal design features of front-end electronics for calorimeters in experiments at the LHC will be highlighted. Some concerns arising in the transition from the research and development and design phase to the construction will be discussed. Future challenges will be indicated.

I. INTRODUCTION

Calorimetry in large detectors at the LHC poses some requirements on readout electronics that are quite different than for any other detector subsystem. The main distinction is, a) in the large dynamic range of energies to be measured; and b) uniformity of response and accuracy of calibration over the whole detector. As in all other functions of the detector, low noise of front-end amplifiers is essential. Unique, too, is the requirement for very low coherent noise, as the energy measurement involves summation of signals from a number of calorimeter sections (towers, strips, preshower detectors). Power dissipation and cooling is a major concern as in any other detector subsystem, in some respects only more so, since all the elements of the signal processing chain require more power due to the large dynamic range, speed of response, high precision, and low noise at higher values of electrode capacitance.

The key requirements on the calorimetry readout electronics are summarized in Table 1. The requirements are clearly most demanding in electromagnetic (EM) calorimetry. The dynamic range is somewhat smaller for hadron calorimeters. However, the noise has to be low, if muons have to be observed, and since in hadron shower energy measurement the signals from a larger volume of the calorimeter have to be added up.

While there are quite significant differences in the principles and the technology among various scintillator-based calorimeters and those based on ionization in liquids, the signal is finally reduced to charge (current) from a capacitive source in all cases, and the signal processing chain – in a simplified picture – could be identical.

Major design differences in the readout design arise in different experiments from trying to balance the answers to two questions: a) how much electronics and what electronic functions need to be on the calorimeter; and b) how to minimize the number of interconnections and transmission lines (copper or fiber) for transfer of information from the calorimeter.

Each experiment uses a unique approach, in which preference of the designers has played a decisive role. One of the design considerations was how near to the signal input to digitize and, consequently, whether to have an analog or digital pipeline. The readout systems were described in some detail in the *Proceedings of the 6th Workshop on Electronics for LHC Experiments, 2000*. The two large hadron collider experiments, CMS and ATLAS, each have several different types of EM and hadron calorimeters for the barrel, end-cap, and forward regions. I will comment here only on some common or unique readout aspects, and not attempt to review readouts for all calorimeter components. ALICE has one EM calorimeter over a small solid angle, based on lead tungstate crystals and avalanche photodiodes as in CMS, but taking advantage of a lower operating temperature (-25C) and a longer shaping time (~ 3 microseconds) to obtain a larger signal.

Table 1: Key Requirements on Calorimeter Readout

1. Energy Resolution
 - EM: $<10\%/\sqrt{E}$; constant term $<0.5\%$
 - Hadr.: $<50\%/\sqrt{E}$; constant term $<3\%$
 - Forward: $<100\%/\sqrt{E}$; constant term $<10\%$
2. Dynamic Range: 16-17 bits
 - Lower limit from electronic noise: $\sim 25\text{-}35\text{ MeV/channel}$ or tower
 - Upper limit from $Z' \rightarrow ee$ and $W' \rightarrow e\nu$: $\sim 3\text{TeV}$
 - Hadr.: from muons to $\sim 1\text{ TeV}$
3. Systematics:
 - (Calibration + Digitization + Uniformity + Stability) $<1\%$; $\sim 0.2 - 0.3\%$
4. Speed and Pileup:
 - Timing (associate events and bunch crossings): $\sigma_t \sim 1\text{-}2\text{ns}$
 - Shaping time: EM $\sim 20\text{ ns}$; HAD $< 20\text{-}50\text{ ns}$
 - Lepton isolation, timing for E $\sim 0.3 - 1\text{ GeV}$

*Work supported by the U.S. Department of Energy: Contract No. DE-AC02-98CH10886.

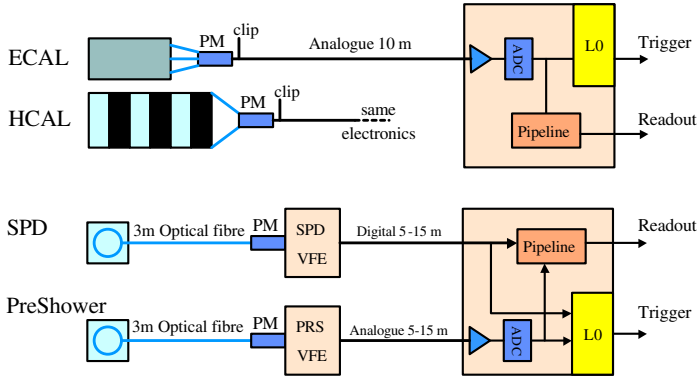

Figure 1. Front-End Electronics for LHC calorimeters. (Design of the Integrator Filter for ECAL and HCAL is by LAL Orsay, and VFE for the Scintillator Pad Detector and for the Preshower is by LPC Clermont-Ferrand.)

II. UNIQUE ASPECTS OF LHC CALORIMETER FRONT-END ELECTRONICS

A. LHCb

Although a limited solid angle experiment, LHCb has a large sampling calorimeter based on scintillator-wavelength shifter technology and on photomultiplier light readout. The readout concept for the four calorimeter components, and the location of various functions, is shown in Fig. 1. ECAL and HCAL have a significantly larger light output with smaller fluctuations and they use a deadtimeless integrator (integrator filter without any switches). The concept is illustrated in Fig. 2. The dominant component of the photomultiplier signal decays exponentially with a time constant of ~ 10 ns, allowing formation of a short pulse by delay line clipping. The flat top provides a degree of independence from small fluctuations in the time of arrival and the shape of the

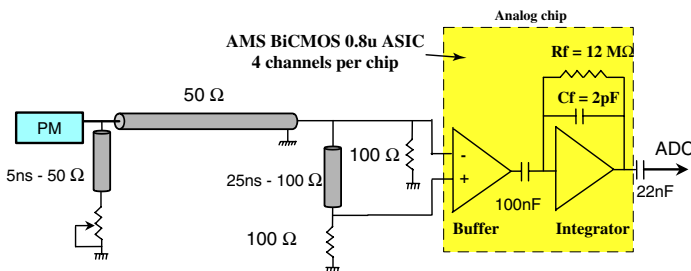
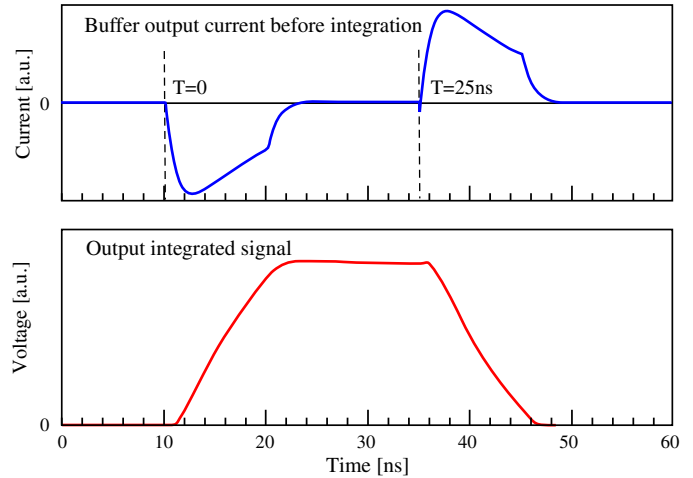

Figure 2. Principle of the Integrator Filter for the LHCb ECAL and HCAL. The exponentially decaying signal is first clipped at the photomultiplier output to 5 ns. The integrator receives the clipped signal, and then after 25 ns the same but with opposite polarity, to provide an output with a flat top, which returns to zero, as shown in Fig. 3.



Strobe on the flat top (≈ 10 ns).
Shaping : $h(t) = \int [i(t) - i(t+25\text{ns})] dt$

Figure 3. Signals in the Integrator Filter in Fig. 2.

signal. At the integrator output, the pileup for consecutive pulses spaced more than 25 ns is negligible. The dynamic range of this circuit is about 4×10^3 .

The scintillator pad detector and the preshower have a lower light output with larger fluctuations, so that switched integrators were found to be more appropriate.

The design for essentially all circuits for LHCb calorimeters has been completed, and prototype circuits completed and tested (also in the test beam). (One more ASIC iteration for the Integrator Filter is planned only for a small change.) The review of calorimeter electronics performed in April, 2001 was, overall, very positive. The only significant finding was that the power distribution system has not been designed yet.

B. CMS Electromagnetic Calorimeter

This is a total energy absorption calorimeter based on lead tungstate (PbWO_4) crystals and avalanche photodiode (APD) readout for the barrel, and vacuum phototriode in the endcaps. An outline of the electronics chain is shown in Fig. 4, illustrating the “light-to-light” readout, with an ADC at the detector and an optical fiber for data transmission for each crystal. This is the most ambitious subsystem in terms of the number of optical fibers. The dynamic range for the ADC is reduced by using four different gains in a configuration called Floating Point PreAmplifier (FPPA)[1], Fig. 6. The signal before and after shaping is shown in Fig. 5. The noise requirements in this case are rather stringent: a) the light signal from lead tungstate is small, resulting in ~ 5 photoelectrons/MeV in a pair of APDs; b) APD gain is expected to be ~ 50 ; and c) the

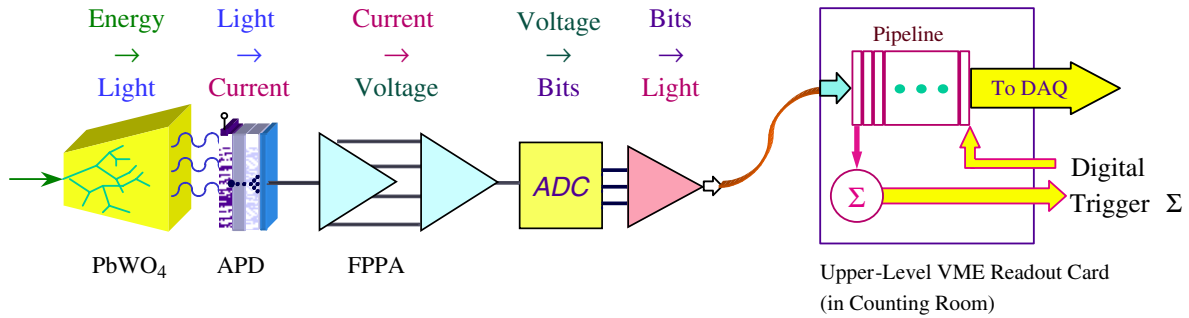

Figure 4. Readout chain for the CMS electromagnetic calorimeter. Preamplifier with range selection (Floating Point Preamplifier – FPPA) and analog-to-digital converter are located at the detector (PbWO_4 crystals with avalanche photodiode readout). There is 1 fiber per crystal for data transmission from the detector. Digital pipelines are in the counting room.

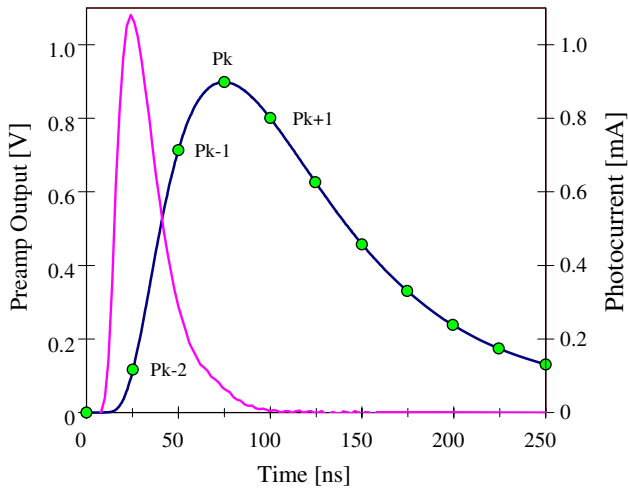

Figure 5. PbWO_4 /APD signal before and after shaping. Sampling points every 25 ns are indicated.

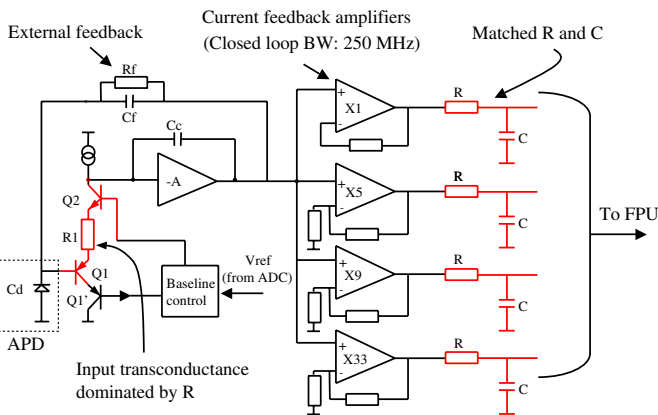

Figure 6. Circuit topology of the CMS ECAL floating point preamplifier. Four samples at different gains are stored every 25 ns. The sample with the highest gain below saturation is selected and fed to the ADC via a multiplexer, resulting in a waveform as in Fig. 7.

capacitance of interconnections and APDs optimized with respect to the crystal and the sensitivity to shower particles is ~ 200 pF. The noise in an ideal case is determined by transistors Q_1 and Q_2 and by R_1 . The signal at the output of the analog multiplexer, composed of analog samples with different gains, is shown in Fig. 7.

The FPPA has been fabricated in bipolar technology and functional tests have been satisfactory, but one more run is in process to satisfy the noise requirements.

Power dissipation per channel is expected to be ~ 1.4 watts, resulting in about 100 kwatt at the detector.

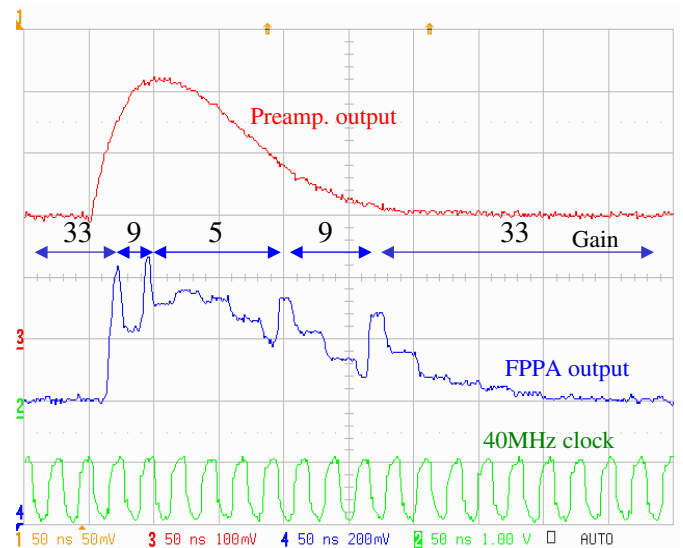

Figure 7. Waveform at the output of the analog multiplexer of CMS ECAL floating point preamplifier (FPPA). It consists of consecutive samples every 25 ns, each sample taken from one of the four amplifiers which provides the best precision for a given signal amplitude (a short transient is superposed as boundaries between different gains are crossed; sample magnitudes are measured at points in between the transients).

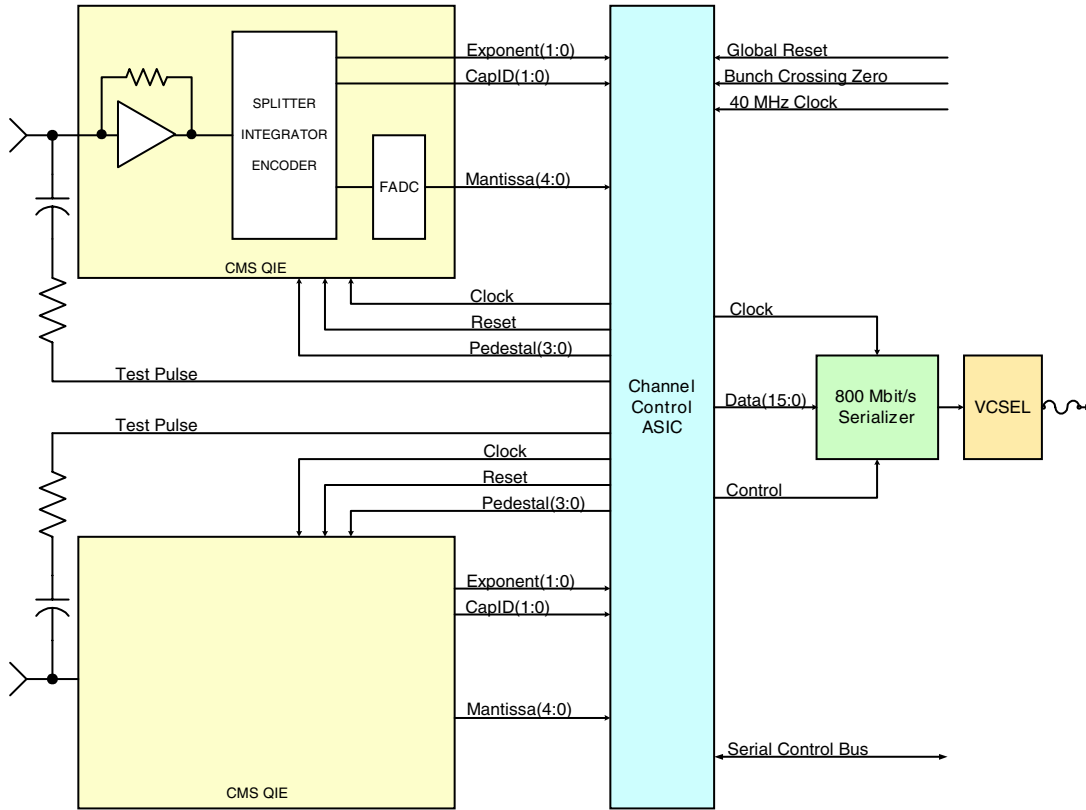

Figure 8. Block diagram of the CMS hadron tile calorimeter readout. The front end, including analog-to-digital conversion, is based on the pipelined multi-ranging integrator and encoder (ref.), known as “QIE”. The encoder is based on a multi-ranging current splitter and a nonlinear flash ADC. Encoded samples are serialized and transferred from the detector by (one) optical link for every two channels.

C. CMS Hadron Calorimeter

The photodetector for the tile calorimeter is a hybrid photomultiplier (HPD), which can operate in the strong magnetic field. This unique approach [2,3], illustrated by the block diagram in Fig. 8, has been developed in an attempt to digitize the signal very near to its source. It combines a multi-ranging integrator and a nonlinear flash ADC, with a response as in Fig. 9. The nonlinear 5-bit ADC provides constant resolution of $\sim 0.9\%$ rms in each range. All of these functions have been incorporated in a single ASIC, realized in a BiCMOS technology. Functional tests of the prototype have been satisfactory. One more run before production may be needed.

D. ATLAS Liquid Argon Calorimeter

Each readout channel has three gain ranges with 12-13 bit dynamic range each and linear response. It is also the only one of the LHC experiments using switched capacitor arrays as analog memories. After digitization, the data are transferred via optical links. The only communication via (differential) copper transmission lines is for analog sums

for level 1 trigger. The power dissipation in the front-end board is ~ 0.7 watts/channel for all functions. The design of all the circuits located on the detectors in the front-end crates, which serve as a “Faraday Cage” (Figs. 10 and 11), has been completed. Analog parts (preamps, shapers, SCAs) are in mass production in radiation-resistant technologies.

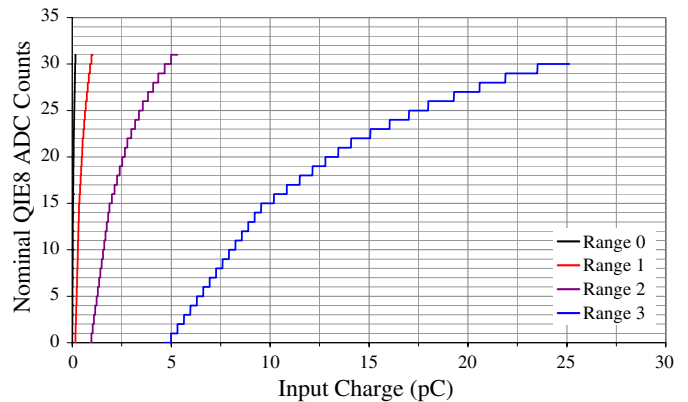

Figure 9. Response of the CMS charge integrator encoder (QIE) over the four gain ranges.

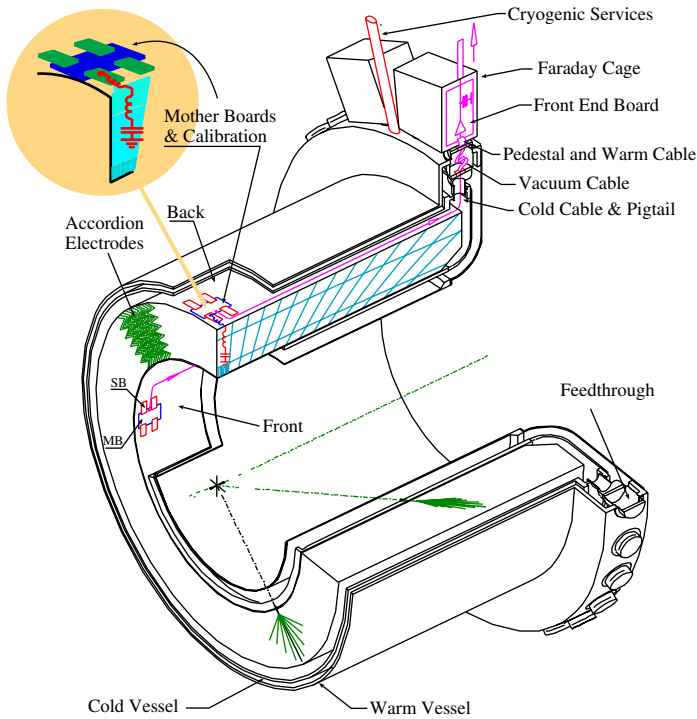

Figure 10. An illustration of the readout of the ATLAS liquid argon (barrel) EM calorimeter. The crates (“Faraday Cage”) containing all the functions outlined in the lower half of Fig. 11 are mounted directly on signal feedthroughs.

The digital part has been prototyped in radiation hard technology. The emphasis in testing has been on fine effects important for calibration and coherent noise. These are illustrated in Figs. 12-14. Due to the uniformity and stability of an ionization calorimetry response, an accurate intercalibration by electronic means is practical. A small effect on calibration (a few tenths of one percent) of the small inductance of electrode connections is illustrated in Fig. 12. This effect is inversely proportional to the shaping time. Fig. 14 shows the dependence of the coherent noise on shielding and grounding of the front-end boards in the front-end crate. An attenuation of the EMI (from digital operations) of $\sim 10^6$ is required to achieve a usable dynamic range approaching 10^5 .

III. DYNAMIC RANGE IN THE FRONT-END

All the readout schemes for a large dynamic range (approaching 10^5) require multiple gain ranges (or multi-ranging) prior to analog-to-digital conversion at the speed of interest at the LHC. To achieve this dynamic range, an input stage with sufficiently low noise – where the noise

of a single input transistor dominates – is required. An example is the configuration in Fig. 15. More generally, the problem is illustrated in Fig. 16. The noise value assumed is for the best bipolar junction transistors and advanced CMOS devices. It corresponds to an equivalent series noise resistance of ~ 15 ohms. Even if the intrinsic device noise could be reduced below this value (by increasing the device width and/or reducing the electron transit time), lower values are difficult to realize in practice due to additional resistances, e.g., in the base or in the metalization in monolithic circuits. The maximum signal at the preamplifier output is likely to be even less than 3 volts, particularly as the trend to lower operating voltages continues. This limits the dynamic range of a linear front-end stage to about 10^5 (an analysis with respect to the current gives the same result). This happens to be just sufficient for EM calorimetry at the LHC.

IV. MAIN CONCERNS FOR LHC CALORIMETRY ELECTRONICS

A. Transition from R&D Mode to Production Mode

A number of ASICs for almost all calorimeters need “one more iteration”. Finalizing an ASIC is a balance between when and where to stop making incremental improvements and the designer’s reluctance to sign off on the final design. This has affected the construction schedules to the extent that electronics has become a critical path item in several calorimeter subsystems.

B. Radiation Hardness

The progress in designing circuits in radiation hard technologies and in testing and qualifying commercial-off-the-shelf components has been good, but this very tedious process will also have an adverse effect on the construction schedules. The advent of 0.25 micron CMOS technology, and the contribution by the CERN group to the design of standard cells, have been most valuable.

C. Low Voltage Regulators

Some readout boards require 10-20 radiation-resistant, low voltage regulators. These are under development by the CERN project RD49 with S. T. Microelectronics. Some development problems appear to have been overcome and a critical evaluation of a large number of samples is expected to be performed soon. These regulators are the most prominent item on the critical path list for the design and construction of readout boards.

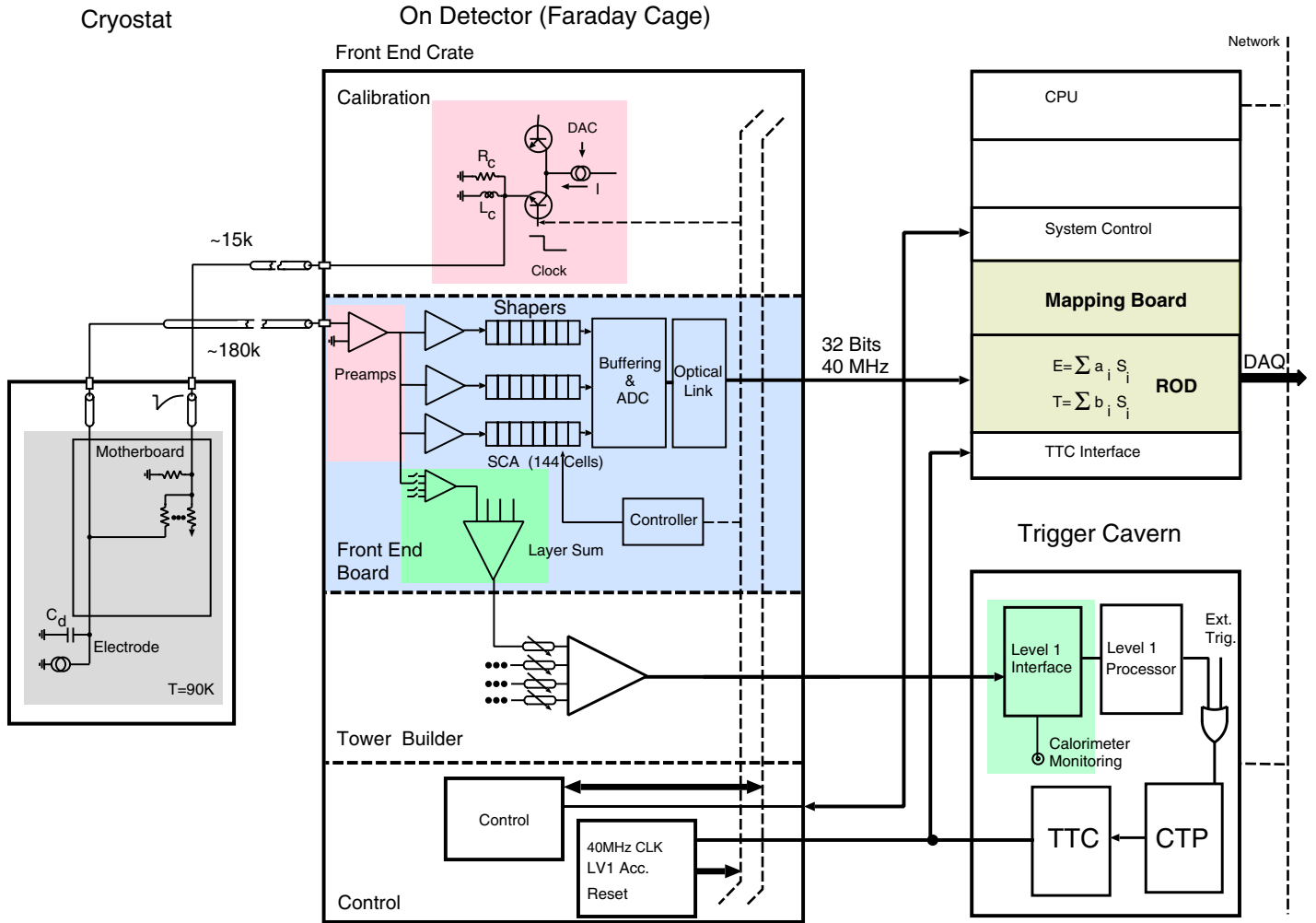

Figure 11. Readout chain of the ATLAS liquid argon calorimeter. After the preamplifiers, the readout chain is identical for all the liquid argon calorimeters. The end-cap hadron calorimeter has preamplifiers based on GaAs technology at the electrodes inside the cryostat. Each preamplifier output is split into three shaping amplifiers with different gains and analog (switched capacitor) memories, and then digitized with 12 bit resolution. Data are transferred from the detector via one optical link for every 128 signal channels.

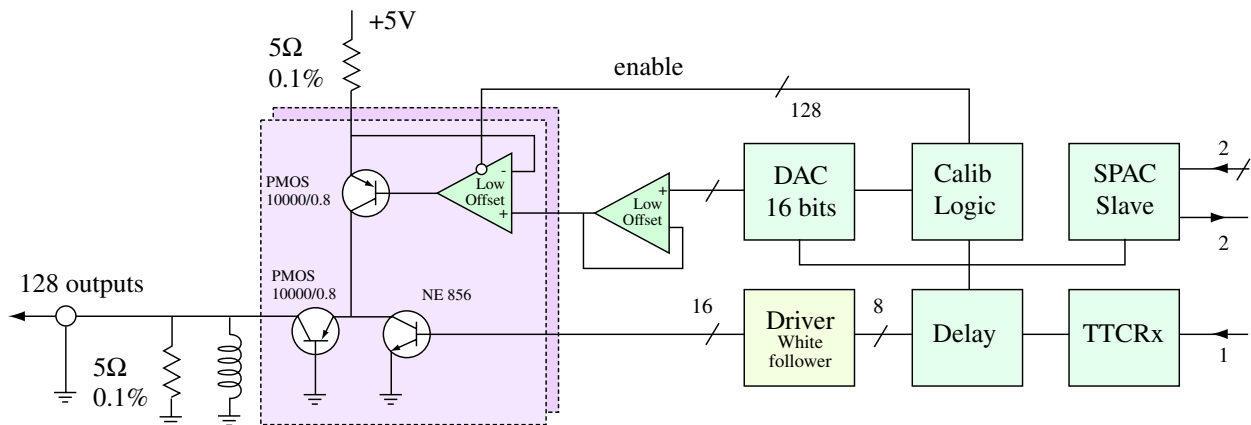

Figure 12. Calibration signal generator. A dc current controlled to 0.1% is switched off to generate on an LR network an exponentially decaying current pulse which approximates closely (within the shaping time) the calorimeter signal.

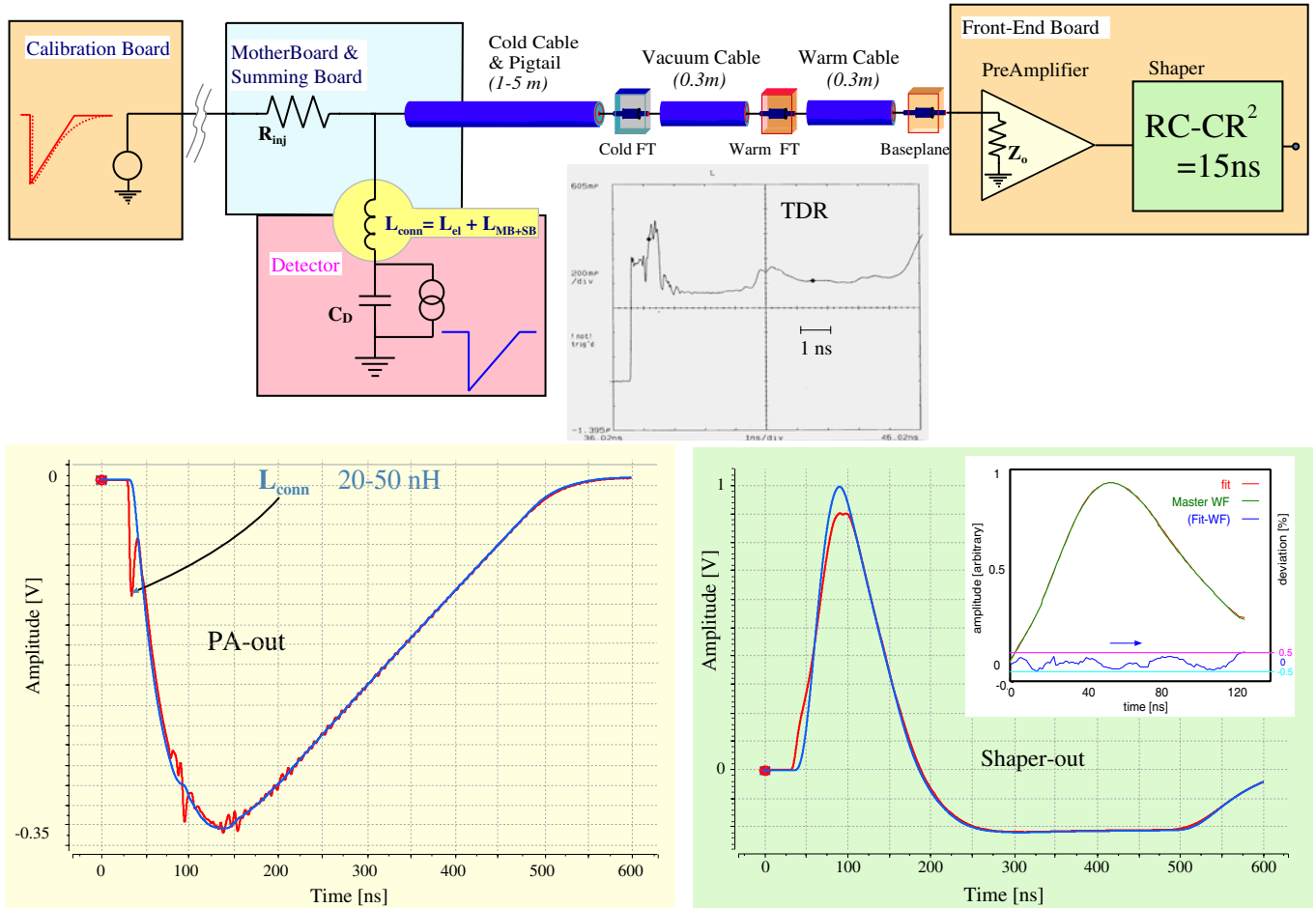

Figure 13. Some characteristic waveforms in the LAr readout chain. There is a very small difference (emphasized in this figure) between the calorimeter “physics signal” and the pulser calibration signal due to slightly different points of injection. The small inductance of electrode connections of about 10-20 nH causes this, requiring a correction in the extraction of the energy information from multiple samples.

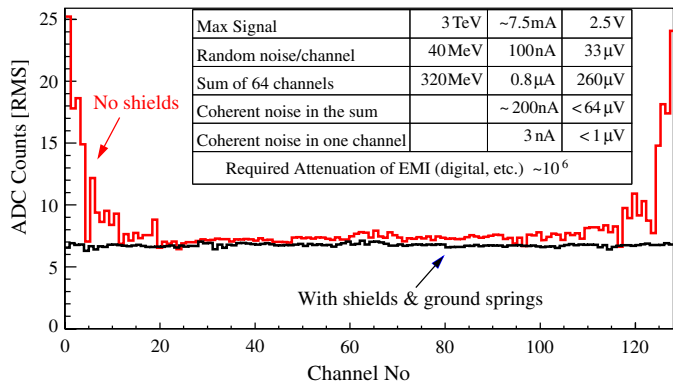

Figure 14. Coherent noise measured for the 128-channel LAr FEB (front-end readout board). Critical role of shielding and ground springs at the input connectors is illustrated, resulting in a coherent noise of only ~ 1 microvolt/channel.

D. Supplying Power at Low Voltage

This is a problem that has received too little attention in all subsystems. The design plans are either rudimentary or nonexistent. In some cases, there is an effort to develop radiation-resistant switching supplies located close to the readout electronics and supplied at a higher voltage (200-300 volts) [4]. Supplying a large calorimeter readout with (typically) 100 kwatt at low voltage (5 volts) from 120 meters away, requires a large amount of copper and cooling of the supply lines. If one allows a voltage drop of 2 volts, a minimum of 25 tons of copper dissipating 40 kwatt is required!

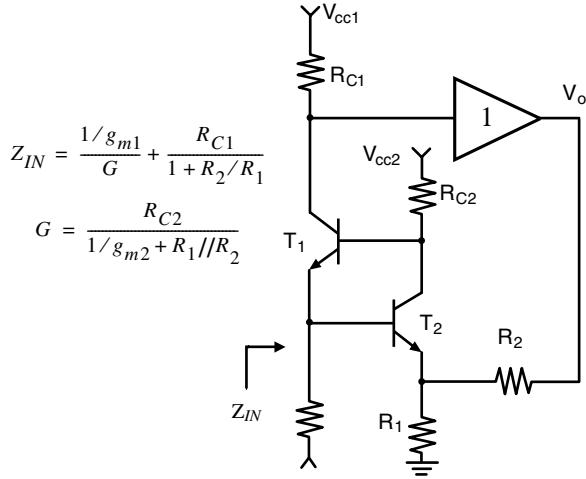

Figure 15. LAr calorimeter preamplifier configuration with well defined input impedance. The conversion gain (output voltage/input current) is determined only by R_{C1} , and the noise is determined only by T_2 .

E. Availability of Semiconductor Technology and Lack of Resources for Spares

We have to assume that some (or most) of the technologies of ASICs will not be available throughout the lifetime of the experiments. This requires careful planning for acquisition of ASICs, and/or additional wafers for any replacement maintenance.

V. FUTURE CHALLENGES – “ENERGY AND LUMINOSITY FRONTIERS”

From recent discussions and studies about future hadron accelerator developments, two major advances are being considered. One is a continuing quest for increasing luminosity – an increase by an order of magnitude at the LHC is already being contemplated. Considering the difficulties that had to be overcome, and the time and effort still being expended in the development of the radiation hard electronics for the present design luminosity, this will be a challenge which will require a renewed major R&D effort.

On a longer time scale, there is also a continuing quest for higher energies (Snowmass 2001). The dynamic range required in EM calorimetry at the LHC is just about at the limit that a front-end amplifier device can accommodate in linear regime, as discussed in Section III. A very large hadron collider (“VLHC”) will require a different approach to the dynamic range problem than the present designs for the LHC.

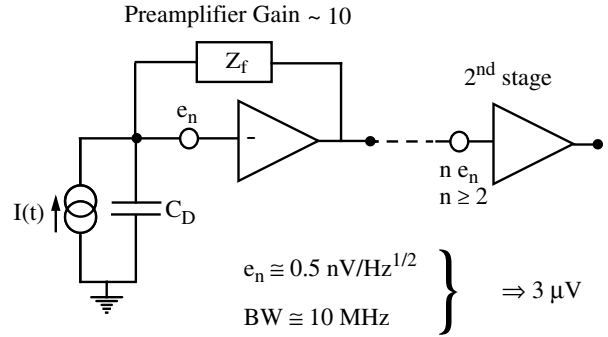

Noise at preamplifier output $\cong 30 \mu\text{V}$ (Gain ~ 10 to overcome second stage noise)

Max signal at preamplifier output $\cong 3 \text{ V}$ (technology dependent)

Max dynamic range (with respect to rms noise) $\sim 10^5$ (or 16-17 bits)

Figure 16. Dynamic range limit for the linear preamplifier is limited by the ratio of the maximum voltage amplitude at the output divided by the noise over the bandwidth of interest.

VI. ACKNOWLEDGEMENTS

The information and some of the material for this report has been generously provided by J. Christiansen for LHCb, P. Denes and J. Elias for the CMS, B. Skaali for ALICE, and W. Cleland and C. de La Taille for ATLAS. Discussions with them are gratefully acknowledged. In the brief comments here, it was not possible to acknowledge the large efforts and individual contributions that went into the development of the elaborate readout electronics for LHC calorimeters.

The author is grateful to his colleague, B. Yu, for his help in preparing this report.

VII. REFERENCES

1. P. Denes, private communication.
2. R. Yarema, *et al.*, “A Pipelined Multiranging Integrator and Encoder ASIC for Fast Digitization of Photomultiplier Tube Signals”, Fermilab-Conf-92/148.
3. T. Zimmerman and M. Sarraj, “A Second Generation Integrator and Encoder ASIC”, *IEEE Trans. on Nucl. Sci.* Vol. 43, No. 3, June (1996), p1683.
4. H. Takai, *et al.*, “Development of Radiation Hardened DC-DC Converter for the ATLAS Liquid Argon Calorimeter”, these Proceedings.