

MONOLITH: A HIGH RESOLUTION NEUTRINO OSCILLATION EXPERIMENT

Tommaso Tabarelli de Fatis
I.N.F.N. - Sezione di Milano
Piazza della Scienza 3, I-20126 Milano, Italy
for the MONOLITH Collaboration

Abstract

MONOLITH is a proposed massive magnetized tracking calorimeter at the Gran Sasso laboratory in Italy, optimized for the detection of atmospheric muon neutrinos. The main goal is to test the neutrino oscillation hypothesis through an explicit observation of the full first oscillation swing. The Δm^2 sensitivity range for this measurement comfortably covers the entire Super-Kamiokande allowed region. Other measurements include studies of matter effects, the NC/CC and $\bar{\nu}/\nu$ ratio with atmospheric neutrinos and auxiliary measurements from the CERN to Gran Sasso neutrino beam. Depending on approval, data taking with part of the detector could start in 2005. The MONOLITH detector and its performance are described.

Talk given at
“Les Rencontres de Physique de la Vallée d’Aoste”,
La Thuile (Italy), March 4-10th, 2001

1 Introduction

The current observations of atmospheric neutrinos ^{1, 2)} are all consistent with a two-state neutrino oscillation in the $\nu_\mu \rightarrow \nu_\tau$ channel. However, the experimental resolution is too poor to clearly resolve the oscillation pattern and models with non-standard ν_μ disappearance dynamics ^{3, 4, 5)} are not ruled out by data. Moreover, scenarios involving admixtures of the electron neutrino (3ν) and of an hypothetical sterile neutrino (4ν), that would accommodate the current phenomenology, are not fully constrained ⁶⁾ and even in the simple two-neutrino oscillation picture, a wide range of oscillation parameters is still allowed.

MONOLITH ⁷⁾ is a proposal for a detector explicitly designed to establish the occurrence of oscillations in atmospheric neutrinos and to discriminate alternative explanations, through the observation of the full first oscillation swing in ν_μ disappearance. This also yields a significantly improved measurement of the oscillation parameters. The occurrence of matter effects in atmospheric neutrino oscillations can also be tested with MONOLITH, exploiting its capability to identify the lepton charge of muon neutrinos. This will constrain 3ν and 4ν scenarios and offer the unique opportunity to test the neutrino mass hierarchy, before the advent of ν -factories.

If approved, the detector will be located at the Gran Sasso Laboratory in Italy, where the measurement of atmospheric neutrinos can be supplemented by measurements in the CNGS beam from CERN.

2 The MONOLITH detector

MONOLITH is a massive tracking calorimeter with a coarse structure and magnetic field. A large modular structure has been chosen for the detector (figure 1). One module consists in a stack of 120 horizontal 8 cm thick iron planes with a surface area of $14.5 \times 15 \text{ m}^2$, interleaved with 2 cm planes of sensitive elements. The height of the detector is about 13 meters. The magnetic field configuration is also shown in figure 1; iron plates are magnetized at a magnetic induction of $\approx 1.3 \text{ T}$. The detector consists of two modules and its total mass exceeds 34 kt.

Glass Spark Counters (resistive plate chambers with glass electrodes) have been chosen as active detector elements. They provide two coordinates with a pitch of 3 cm, and a time resolution of order 1 ns. An external veto made of scintillation counters is foreseen to reduce the background from cosmic ray muons.

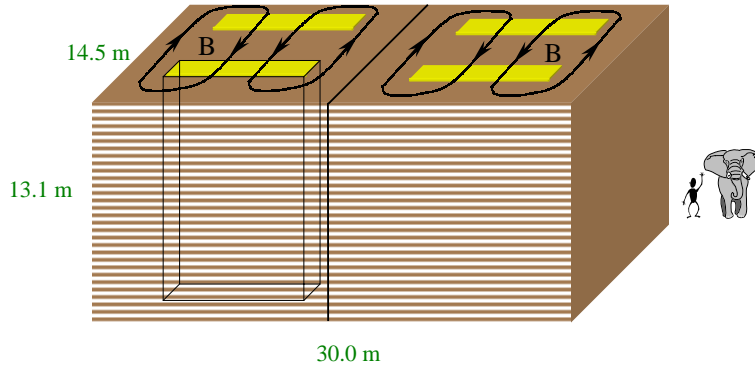

Figure 1: Schematic view of the MONOLITH detector. The arrangement of the magnetic field is also shown.

3 Measurements with atmospheric neutrinos

3.1 Test of ν_μ disappearance dynamics

Oscillation studies with atmospheric neutrinos requires that the energy E and the baseline L of the incoming neutrino be measured in each event. The latter is related to the neutrino direction and may be estimated in charged-current (CC) interactions from the direction of the outgoing lepton. MONOLITH, with a mass comparable to Super-Kamiokande, has a much larger acceptance to muons at high energies, where the muon direction gives a better estimate of the neutrino direction. This results in a considerably improved L/E resolution and overcomes the main limitation in the sensitivity to the oscillation pattern of current atmospheric neutrino experiments.

High energy atmospheric neutrinos bear another advantage: they represent an ideal source for a disappearance experiment, since they naturally comprise the *near* (down-going neutrinos) and a *far* (up-going neutrinos) positions¹. Thus a detailed prior knowledge of neutrino fluxes is not required. The atmospheric neutrino beam is also characterized by a wide range in L/E (from about 1 km/GeV to 10^5 km/GeV), that gives access to a very large range of oscillation parameters and, in particular, results in a unique sensitivity to oscillations if Δm^2 is low.

Figure 2 shows the expected L/E distributions of up-going neutrinos and of the reference sample of down-going neutrinos and their ratio, for $\nu_\mu \rightarrow \nu_\tau$ oscillation with parameters around the current best-fit to Super-Kamiokande data. The figure also shows the allowed regions of the oscillation parameter space of the experiment

¹MONOLITH has an effective threshold on ν_μ -CC events around 3 GeV, where the asymmetry of atmospheric neutrino fluxes, mainly due to geomagnetic effects, is below the percent level⁸).

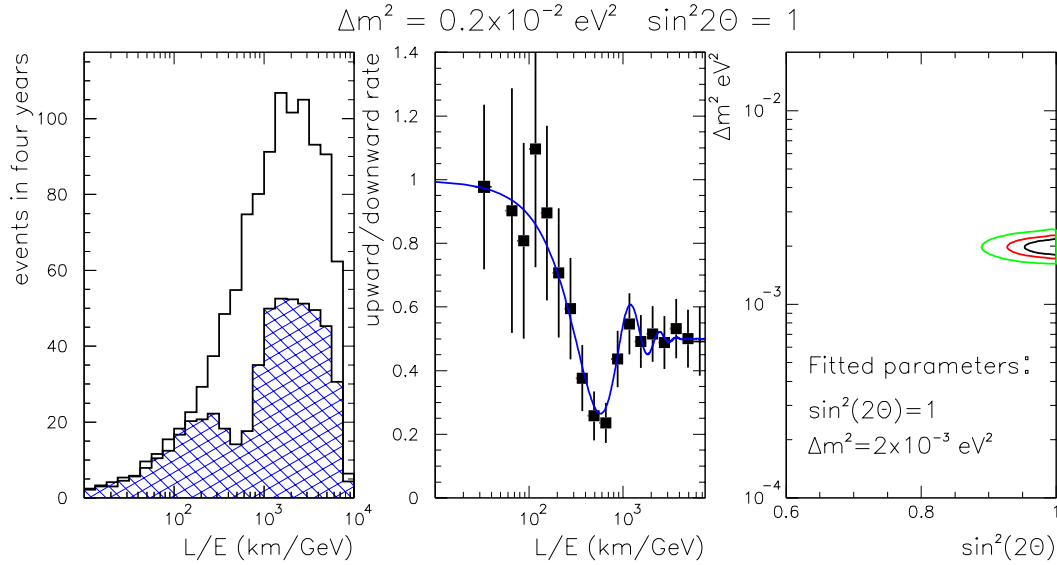

Figure 2: Results of the L/E analysis on a simulated sample in the presence of $\nu_\mu \rightarrow \nu_\tau$ oscillations, with parameters $\Delta m^2 = 2 \times 10^{-3} \text{ eV}^2$ and $\sin^2(2\Theta) = 1.0$. The figure shows from left to right: the L/E spectrum of up-going muon neutrino events (hatched area) and the reference spectrum of down-going muon neutrino events, which are assigned the baseline L they would have travelled if they were produced with a nadir angle equal to the observed zenith angle ⁹⁾ (open area); their ratio with the best-fit of $\nu_\mu \rightarrow \nu_\tau$ oscillation superimposed; the result of the fit with the corresponding allowed regions for oscillation parameters at 68%, 90% and 99% C.L.. The simulated statistics correspond to 25 years of exposure, errors and sensitivity contours correspond to four years.

after four years of exposure.

An oscillation pattern is visible, at clear variance with the unconventional interpretations ^{3, 4, 5)} of Super-Kamiokande data, which share the feature of the absence of a first clear dip in the L/E distribution. A detailed analysis reveals that if the true process is oscillations, the alternative hypotheses can be rejected with more than 99% efficiency at 95% C.L., over the entire region of parameters allowed by Super-Kamiokande (see Fig. 3). The clearness of the oscillation pattern also results in a significantly improved measurement of the oscillation parameters. A precision on Δm^2 better than 10% is anticipated (Fig. 3).

3.2 Detection of matter induced effects

The very long baselines available with atmospheric neutrinos offer the possibility to search for Earth-induced matter effects. In that endeavour, atmospheric neutrino

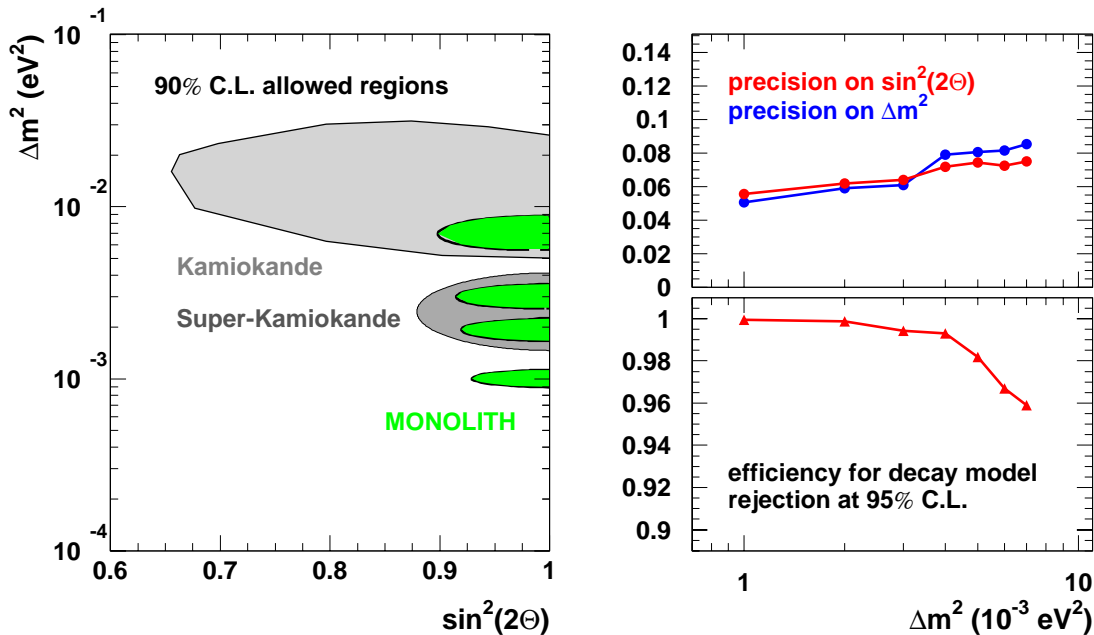

Figure 3: *Left*: Expected allowed regions of $\nu_\mu - \nu_\tau$ oscillation parameters for MONOLITH after four years of atmospheric neutrino exposure. The results of the simulation for $\Delta m^2 = 1, 2, 3, 7 \times 10^{-3}$ eV² and maximal mixing are shown. The 90% allowed regions for $\nu_\mu \rightarrow \nu_\tau$ oscillations of Super-Kamiokande ²⁾ and Kamiokande ¹⁰⁾ experiments are also shown. *Right*: MONOLITH expected precision on oscillation parameters and discrimination power against the decay model of Ref. ³⁾.

experiments are not contested by current and planned conventional accelerator beam experiment, whose baselines are too short for a significant effect.

Matter effects can play an important role if there are significant contributions of ν_e or ν_{sterile} to atmospheric neutrino oscillations. The non-observation of large matter effects has been already exploited by Super-Kamiokande to exclude the pure $\nu_\mu - \nu_{\text{sterile}}$ oscillation hypothesis at 99% C.L. ^{1, 2)}. For a contribution of non-maximal $\nu_\mu - \nu_{\text{sterile}}$ oscillations, matter effects would also manifest themselves in differences in the oscillation patterns for neutrinos and anti-neutrinos. Such differences could be measured with MONOLITH ⁷⁾, thanks to its capability to identify the muon charge, and could yield important constraints on hybrid oscillation scenarios ^{11, 12)}.

Such effects could be detectable even in standard three flavour oscillation scenarios ¹³⁾. A subdominant ν_e mixing could sizeably modify the ν_μ transition probability in particular regions of phase space where the $\nu_\mu \rightarrow \nu_e$ transition becomes

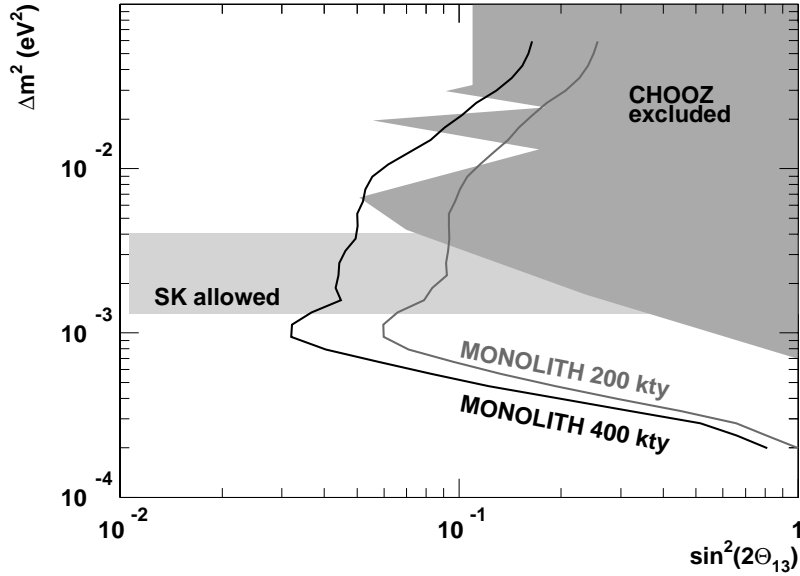

Figure 4: Region of oscillation parameters in the 3ν scenario over which the sign of Δm^2 can be determined at 90% C.L. after 200 kty and 400 kty of MONOLITH exposure. The regions excluded by CHOOZ results and allowed by Super-Kamiokande data are also shown.

resonant in matter. Depending on the sign of Δm^2 , such effects occur either for neutrinos or for anti-neutrinos only. By comparing the neutrino and anti-neutrino distributions in MONOLITH, the sign of Δm^2 , and therefore the neutrino mass hierarchy, could be determined if a signal would be observed.

Figure 4 shows a preliminary estimate of the region of oscillation parameters over which the sign of Δm^2 can be determined at 90% C.L. after 200 kty of MONOLITH exposure. The sensitivity achievable in a long-term run (or with a larger detector), corresponding to an exposure of 400 kty, is also shown. For comparison, the region excluded by CHOOZ¹⁵⁾ and the region allowed by Super-Kamiokande are displayed. This analysis assumes one mass scale dominance for atmospheric neutrinos (i.e. $\Delta m^2 = m_3^2 - m_{1,2}^2$) and maximum mixing in the (2,3) sector, as suggested by Super-Kamiokande data, and no prior knowledge of $\sin^2(2\theta_{13})$. The latter parameter can also be constrained by MONOLITH over a region that will be partly accessible to MINOS¹⁶⁾ and fully accessible to long term low-energy beam projects searching for the subdominant $\nu_\mu \rightarrow \nu_e$ transition¹⁷⁾. These experiments, however, can not measure the sign of Δm^2 .

4 Measurements with neutrino beams

4.1 Oscillation studies with the CNGS beam

The CNGS beam ¹⁴⁾ from CERN to Gran Sasso is optimized for ν_τ appearance experiments and the energy spectrum is somewhat too high to allow the detection of the first entire oscillation swing in a disappearance experiment. Nonetheless, MONOLITH can reconstruct with high efficiency and good resolution about 40000 ν_μ charged-current interactions per year. The systematic error, mainly related to the knowledge of the beam spectra, need to be suitably controlled for a disappearance measurement on the CNGS beam. This is partly achieved in the measurement of the neutral to charged current ratio (NC/CC). In this method looser requirements on the muon reconstruction may be applied and about 100000 events per year (CC+NC) can be reconstructed and classified according their length and shape. Both these method can be used to complement the disappearance measurements with atmospheric neutrinos, in particular if Δm^2 is high.

4.2 Measurements at a neutrino factory

In the long term, MONOLITH could be used as a target detector in a potential neutrino factory beam. Neutrino beams from future muon storage rings ¹⁸⁾ (neutrino factories) will be essentially pure beams of either $\nu_\mu + \bar{\nu}_e$ or $\bar{\nu}_\mu + \nu_e$. The occurrence of $\nu_e - \nu_\mu$ or $\nu_e - \nu_\tau$ oscillations would manifest itself via the appearance of wrong sign muons. It has been checked that MONOLITH, with good muon charge separation and momentum measurement, is well suited for the observation of such oscillations.

Neutrino factories will in particular offer the possibility to measure the Θ_{13} mixing angle, the sign of Δm^2 through matter effects if not observed earlier and, depending on which of the solar neutrino solutions is correct, it might also open the way for the study of CP violation in the neutrino system.

5 Conclusions

MONOLITH is a 34 kt magnetized iron tracking calorimeter proposed for atmospheric neutrino measurements at the Gran Sasso Laboratory in Italy. Its main goal is the proof of the neutrino oscillation hypothesis through the explicit observation of a sinusoidal oscillation pattern. Other goals include tests of the neutrino mass hierarchy in 3ν and 4ν scenarios, trough the investigation of potential matter effects, and auxiliary measurements in the CERN to Gran Sasso beam. In the long term, the detector could also be used in a potential neutrino factory beam.

References

1. Super-Kamiokande Coll., Y. Fukuda et al., Phys. Rev. Lett. **85** (2000) 3999.
2. T. Toshito, (Super-Kamiokande Coll.), hep-ex/0105023, May 2001 (to be published in the proceedings of XXXVIth Rencontres de Moriond)
3. V. Barger et al., Phys. Lett. **B 462** (1999) 109.
4. E. Lisi, A. Marrone, and D. Montanino, Phys. Rev. Lett. **B 85** (2000) 1166.
5. R. Barbieri, P. Creminelli, and A. Strumia, Nucl. Phys. **B 585** (2000) 28.
6. G.L. Fogli, E. Lisi and A. Marrone, hep-ph/0105139, May 2001.
7. MONOLITH Proposal, LNGS P26/2000, CERN/SPSC 2000-031, August 2000 (available at <http://castore.mib.infn.it/~monolith/proposal/>).
8. P. Lipari, T. K. Gaisser and T. Stanev, Phys. Rev. **D 58** (1998) 073003; G. Battistoni and P. Lipari, hep-ph/9807475.
9. P. Picchi and F. Pietropaolo, ICGF RAP. INT. 344/1997, Torino 1997, (CERN preprint SCAN-9710037).
10. Kamiokande Collaboration, Y. Fukuda et al., Phys. Lett. **B 335** (1994) 237.
11. E. Lisi, Nucl. Phys. Proc. Suppl. **91** (2001) 167, and hep-ph/0009269.
12. O. Yasuda, Proceedings of Neutrino Factory workshop NuFACT'00, Monterey, CA, USA, May 21-26, 2000, and hep-ph/0007076.
13. M.C. Bañuls, G. Barenboim and J. Bernabéu, CERN-TH/2001-032 and hep-ph/0102184, February 2001.
14. K. Elsener (editor), CERN 98-02 and INFN/AE-98/05, May 1998; R. Bailey *et al.*, CERN-SL-99-034-DI, June 1999.
15. CHOOZ Collaboration, M. Apollonio *et al.*, Phys. Lett. **B 420** (1998) 397; CHOOZ Collaboration, M. Apollonio *et al.*, Phys. Lett. **B 466** (1999) 415.
16. A. Para, hep-ph/0005012, May 2000.
17. T. Kobayashi, These Proceedings.
18. A. Blondel, These Proceedings.