

EUROPEAN ORGANIZATION FOR NUCLEAR RESEARCH**CERN - PS DIVISION****CERN/PS 2001-048 (BD)****DESIGN OF A MAGNETIC QUADRUPOLE PICK-UP FOR THE CERN PS**

A. Jansson, L. Søby and D.J. Williams

Abstract

A quadrupole pick-up is sensitive to the quantity $\sigma_x^2 - \sigma_y^2$ where σ_x and σ_y are the horizontal and vertical r.m.s. beam sizes. Since it is a non-invasive device, it is potentially very useful for matching and emittance measurements. A magnetic quadrupole pick-up has been developed for the CERN PS. By coupling to the radial component of the magnetic field around the beam, it was possible to eliminate the common-mode problem, which is usually a limiting factor in the use of quadrupole pick-ups. This paper presents the final pick-up design, which is the result of a series of simulations and test prototypes. The performance of the pick-up and its associated electronics is discussed. Preliminary results from the two pick-ups recently installed in the PS machine are also presented.

Dipac2001, 5th European Workshop on Diagnostics and Beam Instrumentation
13-15 May 2001 - ESRF Grenoble

Geneva, Switzerland
18 July 2001

DESIGN OF A MAGNETIC QUADRUPOLE PICK-UP FOR THE CERN PS

A. Jansson, L. Sjøby and D.J. Williams, CERN, Geneva, Switzerland

Abstract

A quadrupole pick-up is sensitive to the quantity $\sigma_x^2 - \sigma_y^2$, where σ_x and σ_y are the horizontal and vertical r.m.s. beam sizes. Since it is a non-invasive device, it is potentially very useful for matching and emittance measurements. A magnetic quadrupole pick-up has been developed for the CERN PS. By coupling to the radial component of the magnetic field around the beam, it was possible to eliminate the common-mode problem, which is usually a limiting factor in the use of quadrupole pick-ups. This paper presents the final pick-up design, which is the result of a series of simulations and test prototypes. The performance of the pick-up and its associated electronics is discussed. Preliminary results from the two pick-ups recently installed in the PS machine are also presented.

1 INTRODUCTION

A quadrupole pick-up measures the quadrupole moment of the transverse beam distribution

$$\kappa = \sigma_x^2 - \sigma_y^2 + \bar{x}^2 - \bar{y}^2, \quad (1)$$

by probing the quadrupole component of the field that the beam induces inside the vacuum chamber. Here, σ_x and σ_y are the r.m.s. beam dimensions in the x and y directions, while \bar{x} and \bar{y} denote the beam position.

An electrostatic pick-up measures the charge collected on electrodes around the beam. The charge is proportional to the electric field in the radial direction, which in polar coordinates (r, θ) is

$$E_r \propto \frac{i_b}{r} \left(1 + 2 \left[\frac{\bar{x}}{r} \cos \theta + \frac{\bar{y}}{r} \sin \theta + \frac{\kappa}{r^2} \cos 2\theta + \dots \right] \right) \quad (2)$$

if the pick-up is round. Here, i_b is the beam current. To measure the κ component, four electrodes at 0° , 90° , 180° and 270° are used. A problem with this setup is that the κ component is a very small part of the signal on each electrode, which requires extremely good common-mode rejection and a large dynamic range in the electronics. To bypass this problem, a new design was proposed [1], where the radial magnetic field is measured instead. If the conducting boundary is at r_0 , this field is

$$B_r \propto \frac{i_b}{r} \left[\left(\frac{\bar{x}}{r} \sin \theta - \frac{\bar{y}}{r} \cos \theta \right) \left(1 - \frac{r^2}{r_0^2} \right) + \frac{\kappa}{r^2} \sin 2\theta \left(1 - \frac{r^4}{r_0^4} \right) + \dots \right] \quad (3)$$

where there is no constant term causing a common-mode signal. For such a pick-up, four antenna loops at 45° , 135° ,

225° and 315° are needed to measure the quadrupole field component (see Fig. 1). A prototype tested in the machine produced encouraging results [2]. Based on the prototype experience, laboratory tests and simulations, a final design has been produced [3].

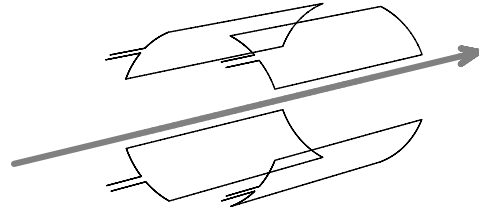

Figure 1: Schematic quadrupole pick-up measuring radial magnetic field. The arrow symbolises the beam.

2 PICK-UP DESIGN

2.1 Bandwidth and Transfer Impedances

The bunch spectrum at injection into the PS normally covers about 20 MHz, with the lowest interesting frequency component at about 75 kHz (betatron frequency). The pick-up was therefore built with a low-frequency cut-off at 75 kHz. On the high frequency end, the usefulness of the pick-up is limited by reduced common-mode rejection at frequencies above 25 MHz (due to standing waves in the loop). The transfer impedances of the pick-up have a flat frequency characteristic in the pass-band and are $35 \mu\Omega/\text{mm}^2$ for the quadrupole signal and $1.5 \text{ m}\Omega/\text{mm}$ for the position signals. These values are for a single antenna loop.

The final pick-up has a length of 508 mm, and a (circular) aperture of 145 mm diameter.

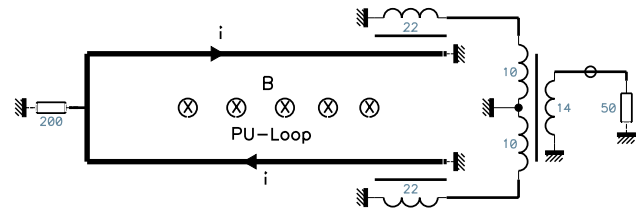

Figure 2: Schematic layout of one antenna loop

2.2 Common-Mode Rejection

Although theoretically a pick-up measuring the radial magnetic field has a perfect common-mode rejection, in prac-

tice the common-mode rejection is finite due to misalignments and parasitic couplings. Misalignments cause constant offsets of the measured signals, and can therefore relatively easily be calibrated away, if these offsets are known from reference measurements. Other parasitic couplings can, however, distort the measured bunch shape, and a lot of effort was therefore made to reduce them. The key issue was the design of the current read-out from the antenna loop. It had to be strictly symmetric to avoid path length differences for the signals. Also, the grounding of the loop had to be close to the read-out transformer, in order to avoid capacitive coupling across the transformer. The thickness of the rod forming the loop restricted the primary winding on the read-out transformer to one turn. Two transformers were therefore used, one on each side of the ground point. A third transformer was then used to combine the two signals. This arrangement, shown in Fig. 2 gave the best common-mode rejection.

2.3 Longitudinal Impedance

In order to obtain reasonable transfer impedances, the conducting boundary had to be moved away from the loops (see Eq. 3), forming a cavity-like structure. To reduce the longitudinal impedance of the pick-up, four metal vanes were introduced in the cavity. By placing these in the symmetry planes of the quadrupole field, they did not reduce the quadrupole transfer impedance of the pick-up. Several sharp peaks in the impedance spectrum due to standing waves in the antenna loops were removed using suitably chosen termination resistors. For high frequencies, an effective screening was produced by a thin resistive layer deposited on the ceramic vacuum tube, which effectively damped all cavity resonances. Therefore, the pick-up has an impedance Z/n of less than 80 m Ω in the entire spectrum.

3 ELECTRONIC SIGNAL TREATMENT

The analog signal chain is shown in Fig. 3. The outputs of the four loops are connected to the hybrid via 0.5 m semi-rigid cables. The output signals from the hybrid are

$$\Delta H = \frac{(A + D) - (B + C)}{2} \quad (4)$$

$$\Delta V = \frac{(A + B) - (C + D)}{2} \quad (5)$$

$$\Delta Q = \frac{(A + C) - (B + D)}{2} \quad (6)$$

so the transfer impedances for the combined signals after the hybrid are twice the transfer impedances for a single loop. The reason why the horizontal and vertical signals appear interchanged (with respect to a standard pick-up) can be understood by comparing Eqns. 2 and 3.

The amplifiers have four channels, each with two different gains: one standard gain for proton beams (peak currents up to 4 A) and a special high gain, low noise mode

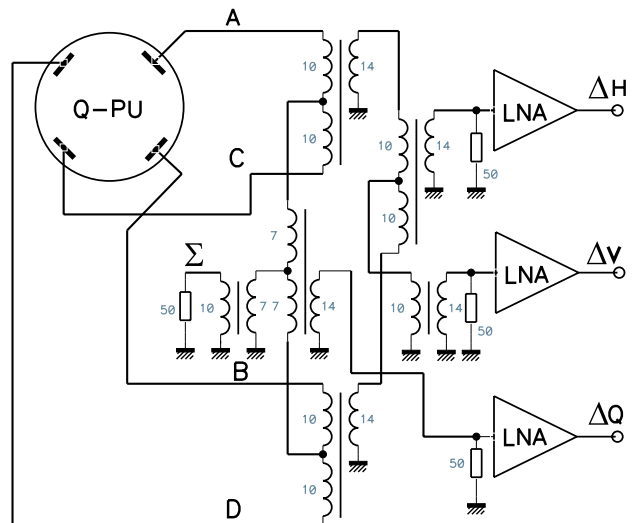

Figure 3: Analog signal chain.

intended for lead ions (peak currents as low as 20 mA). The performance with the high gain is summarised in Table 1.

Three channels are used for the pick-up signals, and the fourth for a reference signal from a nearby wall-current monitor. This is because the pick-up itself cannot measure the beam current, which is needed for normalisation. To make an in-situ measurement of the gain on different channels (including cable attenuation), an external calibration signal can be applied to the inputs. This enables the correction for aging of the electronics, due for example to radiation. After amplification, the combined signals are transmitted to the control room where they are digitised at 500 MS/s by oscilloscopes.

Table 1: Quadrupole PU performance for a 20mA beam.

Channel	ΔQ	ΔH & ΔV
Gain	65 dB	52 dB
Input noise	5.6 μV r.m.s.	5.6 μV r.m.s.
Hybrid output	5.6 μV @ 40 mm ²	6 μV @ 0.1 mm

4 DIGITAL SIGNAL TREATMENT

The data is transferred from the scope to a PC via the GPIB interface, and the analysis is made in a LabView program. In order to resolve single bunches, the data is treated in the time domain. If it is assumed that the quadrupole pick-up and the wall current monitor have the same frequency response, the shape of the pulses is the same in all signals (for a given bunch passage). The problem therefore consists in determining the scaling factor between a pulse on the beam current signal and the corresponding pulse on the pick-up outputs.

First, any timing differences between signals are cor-

rected for (this is presently done by digital re-sampling, but would be better done by adding short lengths of cable). Then, time slices of about one RF period (centred on the bunch passage) are selected. Each selected slice is an N -vector (consisting of N samples), and under the above assumption, corresponding slices are proportional to each other, apart from noise effects and a possible baseline difference. The scaling factor c for the quadrupole signal, for example, is found from the least squares solution of the equation

$$\begin{pmatrix} i_1 & 1 \\ i_2 & 1 \\ \vdots & \vdots \\ i_N & 1 \end{pmatrix} \cdot \begin{pmatrix} c \\ b \end{pmatrix} = \begin{pmatrix} q_1 \\ q_2 \\ \vdots \\ q_N \end{pmatrix}, \quad (7)$$

and the quadrupole moment κ is then calculated from c , using the transfer impedances for the two signals. The same is done for the position signals. This treatment suppresses noise and parasitic signals, and also automatically corrects for amplifier offsets and drifts in the base-line due the lack of DC response.

Notice that differences in the frequency response of the two instruments can be corrected by filtering the signals, if these responses are known. For the moment, however, such sophisticated corrections have not been attempted.

When the position and quadrupole moment at each bunch passage have been calculated, the contribution of the beam position to the quadrupole moment is subtracted using Eq. 1.

5 MEASUREMENT SYSTEM

There are several frequency components in the signal (see Table 2. If these were well separated, they could be distinguished in the signal from a single pick-up using a Fourier transform. However, for the normal PS working points, the frequency separation is usually small. Because of rapid filamentation of the beam size due to the incoherent space charge tune shift, the different frequencies cannot be resolved. Therefore, two pick-ups have been installed in the machine. By installing one pick-up in a location with large horizontal and small vertical beta, and the other in a location where the opposite applies, the known dependence of the amplitudes of the different components on the beta functions can be used to distinguish components that cannot be resolved in frequency. It is also possible to measure the beam emittance with this system[4].

6 MEASUREMENTS WITH BEAM

The measurement system is currently being commissioned, but has already produced interesting signals. The first real signals obtained (see Fig. 4) showed a very large oscillation of the beam widths, signalling a big mismatch. The cause for this was found later to be that some of the quadrupole magnets in the transfer line had wrong currents programmed.

Table 2: Quadrupole signal components due to different kinds of injection errors δ .

Parameter	Frequency	Amplitude
Horizontal Matching	$f_{\text{rev}}(n \pm 2q_h)$	$\beta_h \delta_{\beta_h}$
Vertical Matching	$f_{\text{rev}}(n \pm 2q_v)$	$\beta_v \delta_{\beta_v}$
Horizontal Dispersion	$f_{\text{rev}}(n \pm q_h)$	$2D_h \sqrt{\beta_h} \delta_{D_h}$
	$f_{\text{rev}}(n \pm 2q_h)$	$\beta_h \delta_{D_h}^2$
Vertical Dispersion	$f_{\text{rev}}(n \pm 2q_v)$	$\beta_v \delta_{D_v}$

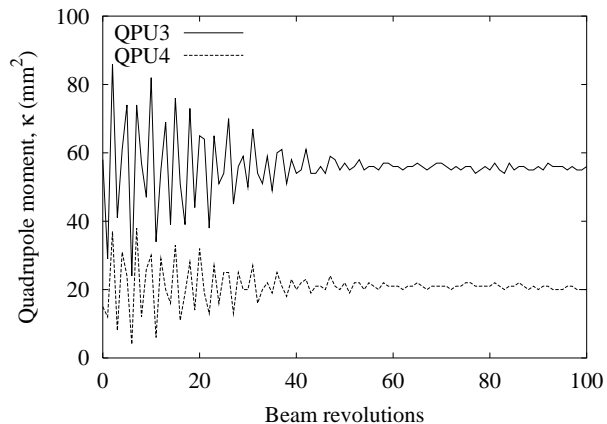

Figure 4: First measurement with the new quadrupole pick-ups, showing large beam size oscillations at injection.

7 SUMMARY AND CONCLUSIONS

A magnetic quadrupole pick-up have been designed for the CERN PS. Three pick-ups have been built and two are now installed in the machine; they are currently being commissioned with proton beams. Used with special low-noise amplifiers, the pick-ups should also be able to detect injection oscillations on the future beam of stacked lead ions from LEIR for the LHC.

8 REFERENCES

- [1] A. Chapman-Hatchett, A. Jansson, D.J. Williams, "A magnetic quadrupole pick-up for the CERN PS", proceedings of PAC99, New York, 1999.
- [2] A. Jansson, M. Lindroos, L. Söby, D.J. Williams, "Measurements with the magnetic quadrupole pick-up in the CERN PS", proceedings of EPAC2000, Vienna, 2000.
- [3] A. Jansson, D.J. Williams, "A new optimised quadrupole pick-up design using magnetic coupling", accepted for publication in Nucl. Instr. Meth. in Phys. Res. A.
- [4] A. Jansson, "Non-invasive measurement of emittance and optical parameters for high-brightness beams in a synchrotron". Dissertation, Stockholm University, 2001.