

THE NEW DIGITAL-RECEIVER-BASED SYSTEM FOR ANTIPROTON BEAM DIAGNOSTICS

M. E. Angoletta, V. Chohan, M. Ludwig, O. Marqvorsen, F. Pedersen
CERN, Geneva, Switzerland.

Abstract

An innovative system to measure antiproton beam intensity, momentum spread and mean momentum in CERN's Antiproton Decelerator (AD) is described. This system is based on a state-of-the-art Digital Receiver (DRX) board, consisting of 8 Digital Down-Converter (DDC) chips and one Digital Signal Processor (DSP). An ultra-low-noise, wide-band AC beam transformer (0.2 MHz – 30 MHz) is used to measure AC beam current modulation. For bunched beams, the intensity is obtained by measuring the amplitude of the fundamental and second RF Fourier components. On the magnetic plateaus the beam is debunched for stochastic or electron cooling and longitudinal beam properties (intensity, momentum spread and mean momentum) are measured by FFT-based spectral analysis of Schottky signals. The system thus provides real time information characterising the machine performance; it has been used for troubleshooting and to fine-tune the AD, thus achieving further improved performances. This system has been operating since May 2000 and typical results are presented.

1 INTRODUCTION

Antiprotons from a target, bombarded with an intense beam from the 26 GeV Proton-Synchrotron (PS), are fed to the AD [1] where they are decelerated in several ramps to a momentum p of about 100 MeV/c. Figure 1 shows the basic AD cycle; bunched-beam deceleration ramps are interspersed with plateaus, where the beam is cooled at fixed p and revolution frequency f_{REV} .

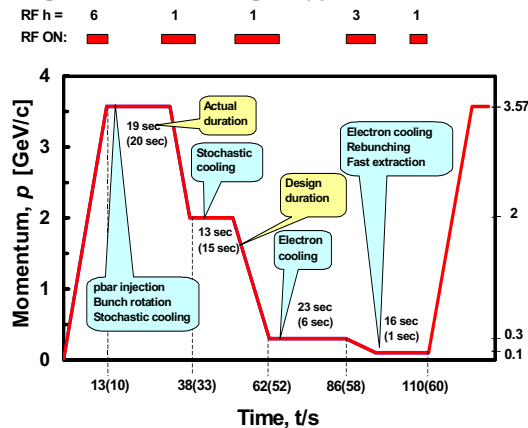

Figure 1: The momentum p during the basic AD cycle.

At the end of the AD cycle the beam is fast ejected to the experimental areas. The intensity of the beam varies

from some 5×10^7 particles at 3.5 GeV/c to some 2.5×10^7 at 100 MeV/c. Traditional DC beam transformers do not work at these low intensities, hence an ultra-low-noise pick-up is used [2]. The new DRX-based, AD beam-diagnostic system acquires and processes the data generated by this pick-up. The system measures beam, momentum spread and mean momentum throughout the AD cycle. It therefore enables a real-time evaluation of the cooling performance during all plateaus.

2 THE SYSTEM

The system is shown in Figure 2. Input from the longitudinal Pick-Up (LPU) (a) feeds 2 variable-gain, remotely-controlled amplifiers (b) [2]. After a 16 MHz low-pass filter stage (c), the signal is digitised by a Pentek 6441 fast ADC (d). The data are digitally down-converted and processed by Pentek's 6510 DRX (e), which is set up before each measurement. Finally the Real-Time Task (RTT), running in the Device Stub Controller (DSC) (f), collects, post-processes and stores the data for later display. The RTT acquires from the AD RF system the information needed to optimise the choice among various user settings; it is synchronised to machine events by a timing reception and generation module (TG8) (g). Users access the system, to evaluate data and to set various parameters, through the local Ethernet via several workstations (WKS), by means of an application program. The system has been providing beam intensity, momentum spread, revolution frequency and debunched beam power spectral density PSD since May 2000.

2.1 Hardware

The LPU head amplifier's response bandwidth is between 0.2 and 30 MHz; its lowest noise level is 1.5 pA/Hz^{1/2} in the 1-3 MHz range [2]. The second stage amplifier has a total gain range of approximately 45 dB, between -10 dB and +35 dB, divided into 3 dB steps. The ADC is the Pentek 6441 module, a dual channel, 12-bit, VMEbus board. We improved its actual S/N ratio by 12 dB, via our own analogue input front-end, bypassing the original input amplifier and low-pass filter. For filtering, we deployed an external 16 MHz-bandwidth anti-aliasing low-pass filter. The ADC operates at externally-controlled sampling frequencies f_s of up to 40 MHz, depending on the beam state and on f_{REV} . The external ADC clock is switchable between a fixed 40 MHz for a debunched beam and $K_i \cdot f_{REV}$ for a bunched beam, where K_i is the largest integer chosen such that $K_i \cdot f_{REV} < 40$ MHz. The DRX is the Pentek 6510 module, a VME board

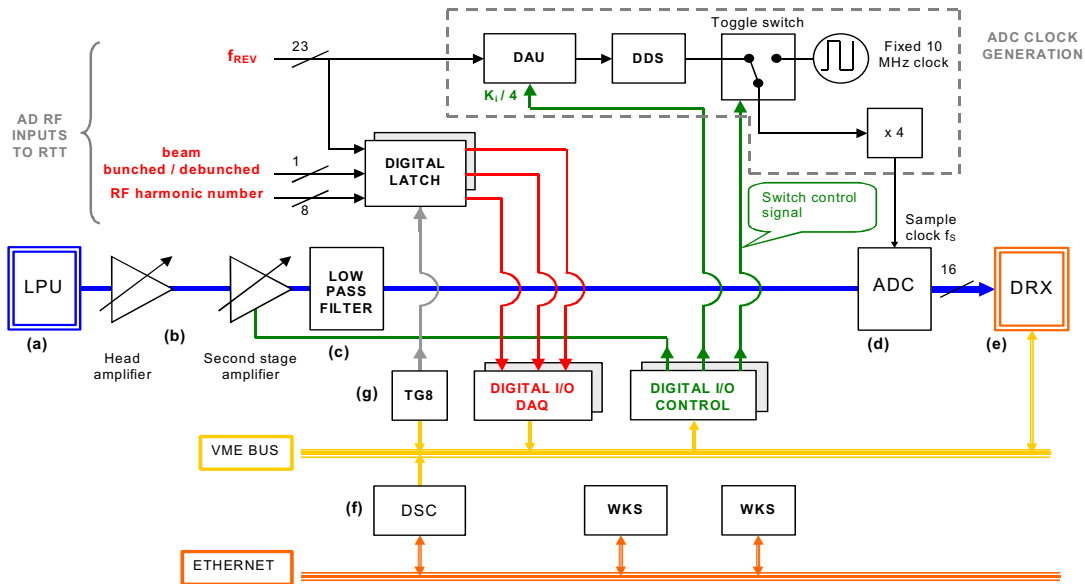

Figure 2: The new DRX-based, AD beam diagnostic system, schematic view. For details on the LPU see [2].

carrying 8 Harris HSP50016 Digital Down Converters (DDC) and one TI TMS320C40 Digital Signal Processor (DSP). This board is responsible for parallel data acquisition, independent digital down conversion and processing of up to 4 digitised inputs. These inputs are pre-processed by the DDC chips, by digitally translating (*downmix*) the input signal to DC, then zooming (*decimation*) on the frequency window of interest. Digital down-mixing, filtering and decimation has these advantages over analogue means: 1) strong rejection of aliased signals due to the digital local oscillator's greater accuracy and to the digital mixer's higher precision, 2) DSP workload greatly reduced and 3) increased flexibility due to the DSP and the DDC chips' re-programmability. Implementing new functions, as a consequence, only requires a software upgrade and no hardware changes. The DSC is a PowerPC VME board running LynxOS.

2.2 Software

Two separate codes have been implemented, the RTT and the low-level code (LLC), running on the DSC and on the DRX, respectively. The RTT sets up the ADC clock and the second stage amplifier. It then instructs the LLC how to set up the DRX board hardware and what processing to use. All these set-up stages depend on beam state, f_{REV} and user requirements. After instructing the LLC, the RTT generates a VMEbus interrupt, thus triggering the LLC to start the DRX acquisition and processing. At the end of the LLC processing stage, the RTT retrieves single output data such as intensity and momentum spread as well as spectra from the DRX.

The LLC performs the measurements from digitised pickup signals. It also manages the DRX board, sets up the required DDCs after receiving a VME-bus interrupt

(as fast as one every 20 ms), acquires data from each DDC, processes them and makes results available to the RTT. The LLC also provides the RTT with full diagnostic information.

The RTT/DRX interface protocol developed is dictated by stringent DRX memory space constraints, combined with users' needs. For example, WKS users need to follow beam status and progress in as closely as possible to real-time. At WKS level, the information is refreshed every few seconds, but actual data are sampled at intervals as short as 20 ms. The RTT/DRX data interchange takes place in the DRX global memory, as this is the only memory visible from the VMEbus.

3 SIGNAL PROCESSING

The processing is carried out at the DRX level, first by the DDCs and then by the LLC. The output is then passed on to the RTT for post-processing and to derive the appropriate physical quantities. The actual processing depends on the beam state: in particular, the Schottky signals [3] are processed only with a debunched beam, thus producing *PSD* plots. With a bunched beam, only the amplitudes at the fundamental (f_{RF}) and second RF Fourier components are considered. Debunched beam data are more affected by noise, whereas bunched beam signals, which are much larger, are less influenced. The data processing stages are detailed in [4] and [5].

3.1 Debunched beam.

At high S/N ratios, such as at high momentum, signal processing is performed on high harmonics, thus speeding data acquisition; at low S/N ratios, low frequency harmonics must be used. The *PSD* of a debunched coasting beam is peaked at f_{REV} , as shown in Figure 3.

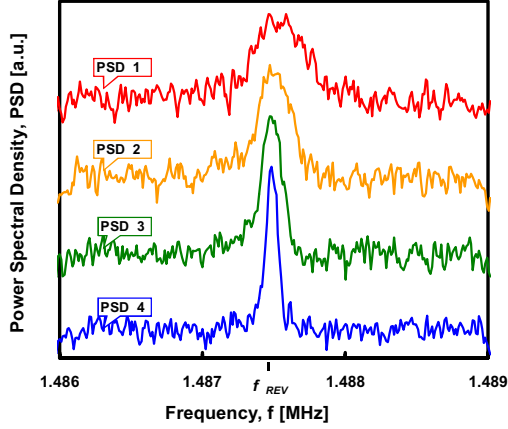

Figure 3: Effect of stochastic cooling on PSD, for a debunched beam, before (PSD 1) and after cooling (PSD 4).

The number of coasting particles N is found from f_{REV} and the area A_{PSD} under the peak of the PSD vs. f curve:

$$N = \frac{\alpha_U}{G_U^2} \cdot \frac{A_{PSD}}{f_{REV}^2} \quad (1)$$

where α_U is a calibration constant and G_U is the global system gain. From the width Δf of the PSD curve at a 2σ height, the momentum spread $\Delta p/p$ is:

$$\frac{\Delta p}{p} = \frac{1}{n \cdot f_{REV} \cdot \eta} \cdot \Delta f \quad (2)$$

where $\eta = (\gamma_{TR}^2 - \gamma^2) / (\gamma_{TR} \gamma^2)$, $\gamma = E/E_0$, $\gamma_{TR} = 4.75$ and n is the harmonic number.

Figure 3 shows the PSD measured by the system, in arbitrary units, as a function of frequency f . Each PSD is the average of 60 complex FFTs, and is calculated every 1400 ms. The ADC f_S is fixed at 40 MHz and n equals 5. The beam cooling is evident from the progressive narrowing. Thus the beam progress can be followed by examining a similar sequence of spectra.

3.2 Bunched beam

For a bunched beam, the ADC f_S is proportional to f_{REV} , thus allowing to track the beam when its revolution frequency changes. At each turn $m = 0, 1, 2, \dots$, the intensity time profile $I(t)$ of a single bunch is approximated, in the interval $[(m-1/2)/f_{REV}; (m+1/2)/f_{REV}]$, by a parabola:

$$I(t) = \frac{3}{4\sqrt{2}} \frac{I_0}{\tau \cdot f_{REV}} \cdot \left(1 - \frac{t^2}{2\tau^2}\right) \quad (3)$$

where I_0 is the DC current intensity per bunch and 2τ is the FWHM.

The experimental Fourier coefficients J_k ($k=1, 2, \dots$) are calculated and then fitted with a truncated series of f/f_{RF}

$$J_k = I_0 \cdot h \cdot \left\{ 2 - \Delta \cdot \left(\frac{f}{f_{RF}}\right)^2 \right\} \quad (4)$$

where $h = f_{RF}/f_{REV}$ is the RF harmonic number. We therefore obtain I_0 and Δ , and thus the bunch size τ :

$$\tau = \frac{1}{2 \cdot \pi \cdot f_{REV}} \cdot \sqrt{\frac{5\Delta}{2}} \quad (5)$$

Integration of the beam profile over time gives the total number N of particles circulating in the machine:

$$N = \alpha_B \cdot \frac{I_0 \cdot h}{f_{REV}} \quad (6)$$

where α_B is a calibration constant. Figure 4 shows f_{REV} and the progress of the antiproton beam intensity in terms of N .

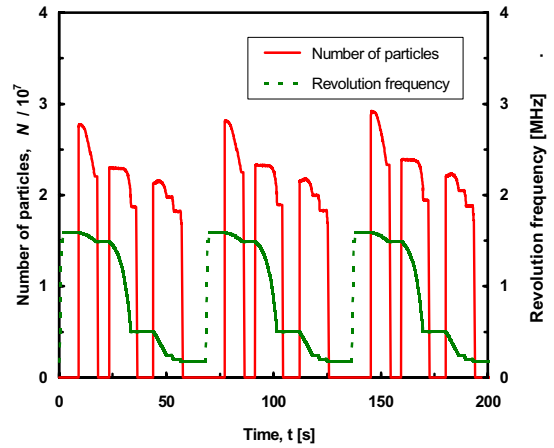

Figure 4: Number of particles N in the beam vs. time, computed from beam current amplitudes at f_{RF} and $2f_{RF}$. Bunched-beam data for 3 AD cycles.

4 FUTURE WORK

An upgrade to the system is under way, to measure tunes from transverse signals using the Beam Transfer Function (BTF). Other improvements will include using the signals from a second LPU optimised for low frequencies. In addition, PU to amplifier cables will be replaced with EMC shielded cables, to reduce environment noise pick-up.

5 REFERENCES

- [1] S. Baird et al., *The antiproton decelerator: AD*, PAC '97, Vancouver, Canada, 1997.
- [2] C. Gonzales, F. Pedersen, *An ultra low-noise AC beam transformer for deceleration and diagnostics of low intensity beams*, PAC '99, NY, 1999.
- [3] D. Boussard, *Schottky Noise and Beam Transfer Function Diagnostics*, CERN/SPS 86-11 (ARF), 1986.
- [4] M. E. Angoletta, *Low-level software for the Pentek 6510 DRX, in application to the new AD beam measurement system*, CERN/PS/Note 2001-004, in preparation.
- [5] M. E. Angoletta, et al.: *Antiproton Beam Parameters Measurement by a New Digital Receiver-Based System*, CERN/PS 2001-016 (BD), in preparation.