



RECEIVED: March 29, 2001, ACCEPTED: July 17, 2001

Hagedorn transition, vortices and D0 branes: lessons from $2 + 1$ confining strings

Ian I. Kogan^a and Martin Schvellinger^{ab}

^a*Theoretical Physics, Department of Physics, University of Oxford
1 Keble Road, Oxford, OX1 3NP, UK*

^b*Center for Theoretical Physics, Massachusetts Institute of Technology
77 Massachusetts Avenue, Cambridge MA 02139, USA*

E-mail: kogan@thphys.ox.ac.uk, martin@thphys.ox.ac.uk

Alex Kovner

Theory Division, CERN

CH-1211, Geneva 23, Switzerland and

*Department of Mathematics and Statistics, University of Plymouth
Plymouth PL4 8AA, UK*

E-mail: a.kovner@plymouth.ac.uk

ABSTRACT: We study the behaviour of Polyakov's confining string in the Georgi-Glashow model in three dimensions near confining-deconfining phase transition described in [33]. In the string language, the transition mechanism is the decay of the confining string into D0 branes (charged W^\pm bosons of the Georgi-Glashow model). In the world-sheet picture the world-lines of heavy D0 branes at finite temperature are represented as world-sheet vortices of a certain type, and the transition corresponds to the condensation of these vortices. We also show that the “would be” Hagedorn transition in the confining string (which is not realized in our model) corresponds to the monopole binding transition in the field theoretical language. The fact that the decay into D0 branes occurs at lower than the Hagedorn temperature is understood as the consequence of the large thickness of the confining string and finite mass of the D0 branes.

KEYWORDS: Confinement, Duality in Gauge Field Theories, Bosonic Strings, D-branes.

Contents

1. Introduction	1
2. Confining strings in the Georgi-Glashow model	4
2.1 The string action	6
2.2 The string is soft ... and therefore rigid!	7
2.3 The W^\pm bosons — the D0 branes of confining string	10
3. How does the string melt?	13
3.1 Deconfinement in the Georgi-Glashow model	14
3.2 The monopole binding as the Hagedorn transition	16
3.3 Vortices on the world-sheet — open strings and charged particles	17
3.4 D0 branes destroy the string	20
4. Discussion	22

1. Introduction

What happens to strings at very high temperatures is one of the Big questions of string theory. In the early days of dual resonance models and hadronic bootstrap the exponential growth in the one-particle density of states

$$\rho(m) \sim m^a e^{bm} \tag{1.1}$$

led to the famous Hagedorn transition [1]. This type of spectrum first arose in the context of statistical bootstrap models [1, 2, 3] and, for hadrons, such behaviour indicates that they are composed of more fundamental constituents [4]. In fundamental string theories we find the same kind of spectrum (see for example [5]), and a search for hints to the existence of ‘string constituents’ is of great interest. What lies beyond the Hagedorn temperature? Is this temperature limiting or is there a high-temperature phase which reveals the fundamental degrees of freedom? And is it true that for all types of string theories there is the same universal physics or different classes may have totally different high-temperature behaviour?

A lot of effort has been invested into the study of the Hagedorn transition in the critical (super)strings. There is enormous literature on this subject, some references (but by no means all) can be found, for example in [6]. For weakly coupled critical

(super)strings the Hagedorn transition can be described as Berezinsky-Kosterlitz-Thouless (BKT) [7, 8] transition on a world-sheet [9]–[12]. It is due to the "condensation" of the world sheet vortices. It has been also suggested that the transition in some cases may actually be first order [11] (see also discussion in [12]).¹ Above the Hagedorn temperature the vortices populate the world-sheet and we have a new phase. From the target space point of view we are talking about tachyonic instabilities for non zero winding modes in the imaginary time direction (thermal winding modes).²

Although much have been understood, many aspects of hot string theory remain mysterious. For example, it is thought that for critical (super)strings the whole idea of using canonical Gibbs ensemble may be not justified, since the canonical and the micro-canonical ensembles are found to be inequivalent [3, 15]. Besides the whole notion of temperature and canonical ensemble is not well defined in the presence of gravity (see [11] and references therein) which necessarily exists in theories of critical strings. In the more general case of interacting strings we do not know with certainty what the fundamental degrees of freedom are³ and thus what is their role at high temperature. Recently it was suggested in the framework of the Matrix Model description of the Hagedorn transition, that the fundamental string decays into D0 branes [16] (for references on thermodynamics in Matrix String theory see [17] and references therein). Thus it could be that D0 branes are the fundamental degrees of freedom in the hot phase.

Since non abelian confining gauge theories are strongly linked to strings, we may hope to glean some insight about the high temperature behaviour of strings from the study of the deconfined phase of gauge theories. When QCD emerged as the fundamental theory of strong interactions, it was suggested that there is a deconfining phase transition [18] during which the symmetry of the centre of the gauge group in electric representation is broken. In the dual magnetic picture this corresponds to the restoration of the true global magnetic symmetry Z_N (for $SU(N)$ gauge theory) [19] — for more details see [20]. The lore is that these two transitions are the same. The confining phase of QCD should be describable by some string theory. At least in the large N limit we hope it is a weakly coupled string with coupling of order $1/N$ [21]. Above the deconfining transition the string description does not make sense. This must mean that the string itself undergoes some kind of a phase transition. This

¹In the recent paper [13] it was shown that in non-commutative open string theory which is decoupled from gravity, in no more than five space-time dimensions the Hagedorn transition is second order.

²In some cases extra symmetry can protect the theory from tachyonic instabilities. For example it was shown in [14] that the theory with $\mathcal{N} = 4$ supersymmetry admits BPS solutions that do not suffer from Hagedorn-type instabilities. However for generic string theory these instabilities must happen.

³M,F,S theories, Matrix Models, etc. give us a lot of new exciting hints, but we still do not have a solid theoretical concept.

picture is very attractive. If this is the case, we are definitely not looking for a grey cat in a dark room, since the high temperature phase is described in terms of quarks and gluons and we know the fundamental lagrangian which determines their properties. The problem is that we still have no idea what string theory we are dealing with (recent results based on AdS/CFT duality [22] may turn out eventually to be useful in this respect) for the simple reason: so far there is no consistent theory of QCD confinement. It may in fact be quite an unusual string theory. For example, the analysis of the high-temperature partition function of a chromoelectric flux tube in the large N limit suggests that the effective string at short distances has an infinite number of world-sheet fields [23]. Whether deconfinement transition of gauge theories is related to the Hagedorn transition of strings is also not quite clear. The relation between the two, using AdS/CFT correspondence was discussed recently in [24] (see also earlier paper [25]) where it was found that in the strong coupling regime the deconfinement transition takes place before the Hagedorn transition. The situation at weak coupling (the physical limit for gauge theories) is not known.

Still, it is likely that the hot phases of gauge theories and string theories have common physics. For example, using the fact that in the deconfining phase the free energy is proportional to N^2 while in confining phase it must be $O(1)$ one can argue [26] that smooth world-sheets must disappear.

All things considered, it would be very interesting to have a model where we know both, the mechanism of confinement and the string description at low energies on one side, and the detailed picture of deconfinement phase transition and the deconfining phase on the other side. A model like this would be useful to learn as much as we can about the transition in string theory in a controlled setting.

Such a model in fact does exist. It is the confining Georgi-Glashow model in $2 + 1$ dimensions. It was shown by Polyakov long ago [27, 28] that this theory is linearly confining due to the screening in the plasma of monopole-instantons. In 1996 Polyakov proposed the description of the confining phase of this theory based on the so-called confining strings [29]. Induced string action can be explicitly derived for compact QED [29, 30] and it was found that this nonlocal action has derivative expansion describing rigid string [31]. For more details see [32] and references therein.

Recently the deconfining transition in this theory has been studied in detail in [33]. The critical temperature for the transition has been calculated and it was shown that transition itself is in the universality class of the two dimensional Ising model. The discussion in [33] was however purely field theoretical. The purpose of the present paper is to relate the analysis of [33] to Polyakov's confining string picture and to discuss various aspects of the transition from the string perspective.

The outline of this paper is the following. In section 2 we discuss the properties of the confining string in the Georgi-Glashow model. Rather than introducing the Kalb-Ramond field [34] (like in [29]) we use the direct correspondence between field configurations and the summation over closed string world-sheets. The integration

over the field degrees of freedom leads then directly to the string action. This string will be referred to henceforth as the confining string. An advantage of this derivation is that it makes explicit an important and quite unusual property of the confining string, namely that the fluctuations of this string with large momenta (larger than the inverse thickness of the string) do not cost energy. This is a dynamical extension of the so called zigzag symmetry introduced by Polyakov [29]. We also show that the heavy charged particles of the Georgi-Glashow model (W^\pm bosons) appear as D0 branes in the string description.

In section 3 we discuss the confining string at finite temperature. First, we show that the Hagedorn temperature corresponds in the field theoretical language to the temperature at which the monopole-instantons become bind in pairs. This temperature arises naturally in the Georgi-Glashow model, if one neglects the effects of the charged particles at finite temperature. We also show that the world-sheet vortices which are usually discussed in the context of the Hagedorn transition, physically correspond to the trajectories of the endpoints of an open string propagating in the compact euclidean time. The actual mechanism of the deconfining transition in the Georgi-Glashow model though is quite different. The transition is due to the appearance of the plasma of charged particles, or in the string language — D0 branes. Since a trajectory of a D0 brane bounds a world-sheet of an open string, such a trajectory also corresponds to a vortex on the string world-sheet. These vortices are however of a somewhat different kind, since the string coordinates satisfy the Dirichlet rather than Neuman boundary conditions. At high temperature the string world-sheet is destroyed by appearance of these vortices, or in the target space picture the string is broken into short segments which connect the D0 branes. This mechanism, although it can be presented in the string language, is essentially field theoretical in origin. It is driven by physics on short distance scales — shorter than the physical thickness of the string, where the stringy degrees of freedom are absent. Due to the large thickness of the confining string and relative lightness of the D0 branes, the deconfining transition precedes the Hagedorn transition, rendering the latter irrelevant.

Finally in section 4 we conclude with discussion of our results.

2. Confining strings in the Georgi-Glashow model

In this section we give the derivation of Polyakov's confining string and discuss some of its striking physical properties. Note that in the present derivation we do not use Kalb-Ramond fields.

Consider the 2+1 dimensional $SU(2)$ gauge theory with a scalar field h in the adjoint representation. The action of the theory is

$$S[A_\mu, h] = -\frac{1}{2g^2} \int dx^3 \operatorname{tr}[F_{\mu\nu} F^{\mu\nu}] + \int dx^3 \left(\operatorname{tr}(D_\mu h)^2 + \frac{\lambda}{4} (2\operatorname{tr} h^\dagger h - v^2)^2 \right), \quad (2.1)$$

where we use matrix notations $A_\mu = \frac{i}{2}A_\mu^a\tau^a$, $F_{\mu\nu} = \partial_\mu A_\nu - \partial_\nu A_\mu + [A_\mu, A_\nu]$, $h = \frac{i}{2}h^a\tau^a$, $D_\mu h = \partial_\mu h + [A_\mu, h]$ and the normalisation $tr(\tau^a\tau^b) = 2\delta^{ab}$. We will be working in the weakly coupled regime, $v \gg g^2$. In this regime the SU(2) gauge group is broken to U(1) by the large expectation value of the Higgs field. Perturbatively the photon associated with the unbroken group is massless, but the Higgs field as well as the W^\pm gauge bosons are heavy with masses $M_H^2 = 2\lambda v^2$ and $M_W^2 = g^2 v^2$, respectively. Furthermore, perturbatively the theory looks like electrodynamics with spin one charged matter. At large distances the non-perturbative effects become very important, so that the photon acquires mass and the W^\pm become linearly confined with a non-perturbatively small string tension. These non-perturbative effects according to Polyakov [28] are due to the contributions of monopole instantons. The monopoles have Coulomb interactions and form a plasma in the sense of the 3-dimensional Euclidean path integral. The ‘‘Debye screening’’ in this plasma provides for a finite photon mass. The low energy physics of the theory is described by the effective lagrangian written in terms of the dual photon field ϕ ,

$$S[\phi] = \int dx^3 \left[\frac{g^2}{32\pi^2} \partial_\mu \phi \partial^\mu \phi + \frac{M_\gamma^2 g^2}{16\pi^2} (1 - \cos \phi) \right]. \tag{2.2}$$

The monopole induced photon mass is $M_\gamma^2 = \frac{16\pi^2\zeta}{g^2}$. We use the notations of reference [33], where the monopole fugacity is $\zeta = \zeta_0 \frac{M_W^{7/2}}{g} \exp[-\frac{4\pi M_W}{g^2} \epsilon(\frac{M_H}{M_W})]$, with ζ_0 a numerical constant while $\epsilon(\frac{M_H}{M_W})$ takes values between 1 and 1.787 and approaches unity for large values of $\frac{M_H}{M_W}$ (see [33] and references therein).

The effective action eq. (2.2) describes only the dynamics of the photon field and is valid at energies below the scale M_W . The short distance physics will be important for us to some extent in the discussion of the phase transition. We will come back to this question later, but for now let us discuss the effective lagrangian eq. (2.2) as it is. It exemplifies in a very simple manner the mechanism of confinement in this theory. First, note that the theory has more than one vacuum state. In particular $\phi = 2\pi n$ for any integer n is the classical ground state. Therefore the classical equations of motion have wall-like solutions — where the two regions of space, say with $\phi = 0$ and $\phi = 2\pi$ are separated by a domain wall. The action density per unit area of such a domain wall is easily estimated from the action eq. (2.2) as

$$\sigma \propto g^2 M_\gamma. \tag{2.3}$$

As discussed in detail in [27, 28] the fundamental Wilson loop when inserted into the path integral with action eq. (2.2) induces such a domain wall solution with the result

$$\langle W(C) \rangle = \exp\{-\sigma S_m\}, \tag{2.4}$$

where S_m is the minimal area subtended by the contour C . Thus, the string tension is precisely equal to the wall tension of the domain wall. The domain wall in fact is nothing but the world-sheet of the confining QCD string.

The expression for the expectation value of the Wilson loop is the starting point for Polyakov’s derivation of the action for the confining string in [29]. We will, however, follow a slightly different path which in our view makes it more straightforward to understand some physical properties of the confining string.

2.1 The string action

Since the string world-sheet is the domain wall in the effective action, we will integrate in the partition function all degrees of freedom apart from those that mark the position of the domain wall. To do this let us split the field ϕ into the continuous and the discrete parts

$$\phi(x) = \hat{\phi}(x) + 2\pi\eta(x), \tag{2.5}$$

where the field $\hat{\phi}$ is continuous but bounded within the vicinity of one “vacuum”

$$-\pi < \hat{\phi}(x) < \pi \tag{2.6}$$

and the field η is integer valued. Clearly, whenever $\eta(x) \neq 0$, the field ϕ is necessarily not in the vicinity of the trivial vacuum $\phi = 0$. Thus, the points in space where η does not vanish mark in a very real sense the location of a domain wall between two adjacent vacua.

We now substitute the decomposition eq. (2.5) into eq. (2.2) and integrate over $\hat{\phi}$. The partition function is

$$Z = \int \mathcal{D}\hat{\phi}\mathcal{D}\eta \exp\left(- \int dx^3 \left[\frac{g^2}{32\pi^2} \partial_\mu(\hat{\phi} + 2\pi\eta)\partial^\mu(\hat{\phi} + 2\pi\eta) + \frac{M_\gamma^2 g^2}{16\pi^2} (1 - \cos \hat{\phi}) \right]\right). \tag{2.7}$$

At weak coupling the field $\hat{\phi}$ can be integrated out in the steepest descent approximation. This means that the equations of motion for $\hat{\phi}$ have to be solved in the presence of the external source η and keeping in mind that $\hat{\phi}$ only takes values between $-\pi$ and π . Let us assume for this solution that the surfaces along which η does not vanish are few and far between. Also we will limit the possible values of η to 0, 1, -1 . In the context of the effective lagrangian eq. (2.2) this is the “dilute gas” approximation. However as a matter of fact, as we will see below, this exhausts all physically allowed values of η . Then, the qualitative structure of the solution for $\hat{\phi}$ is clear. In the bulk, where η vanishes, the field $\hat{\phi}$ satisfies normal classical equations. When crossing a surface S on which $\eta = 1$, the field $\hat{\phi}$ must jump by 2π in order to cancel the contribution of η to the kinetic term, since otherwise the action is UV divergent. Thus the solution is that of a “broken wall” — far from the surface the field $\hat{\phi}$ approaches its vacuum value $\hat{\phi} = 0$, it raises to π when approaching S_m , then jumps to $-\pi$ on the other side of the surface and again approaches zero far from the surface. The profile of the solution for smooth S (in this case a plane) is depicted on figure 1.

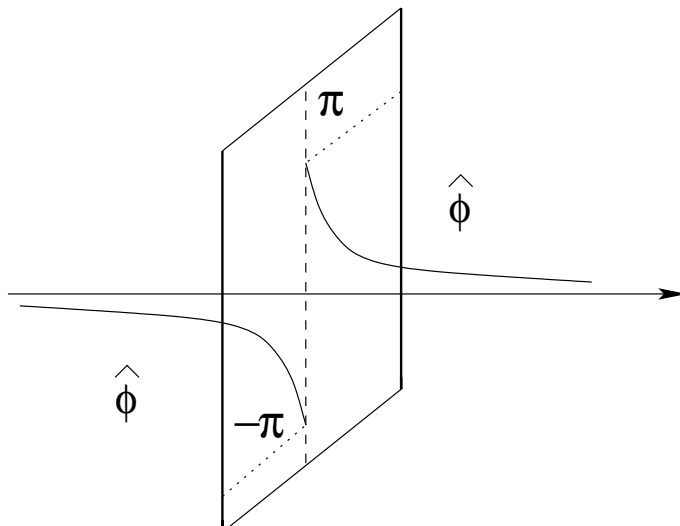

Figure 1: Schematic representation of the solution profile of the $\hat{\phi}$ field as a function of the coordinate perpendicular to the domain wall.

Since outside the surface the field $\hat{\phi}$ solves classical equations of motion, clearly the profile of $\hat{\phi}$ is precisely the profile of the domain wall we discussed above. The only difference is that this wall is broken along the surface S_m and the two halves of the solution are displaced by 2π with respect to each other. The sole purpose of this discontinuity, as noted above is to cancel the “would be” UV divergent contribution of η to the kinetic term in the action. Thus the action of our solution is precisely

$$S[\eta] = \sigma S = \sigma \int d^2\xi \frac{\partial X_\mu}{\partial \xi^\alpha} \frac{\partial X_\mu}{\partial \xi_\alpha}, \quad (2.8)$$

where ξ are the coordinates on the surface S and X_μ are the coordinates in the 3-dimensional space-time. This is precisely the Polyakov’s action of a free string, which classically is equivalent to the well Nambu-Gotos string action.

Of course the confining strings in the Georgi-Glashow model are not free. The thickness of the region in figure 1 in which the field $\hat{\phi}$ is different from zero, is clearly of order of the inverse photon mass M_γ^{-1} . Thus, when two surfaces come within the distance of this order they start to interact. In principle, this interaction can be calculated by just finding the classical solution for $\hat{\phi}$ in this situation. Now, however we want to discuss one particular property of the confining strings - their rigidity.

2.2 The string is soft . . . and therefore rigid!

The Polyakov’s action we have derived in the previous subsection is of course only the long wavelength approximation to the actual action of the confining string. It is only valid for string world-sheets which are smooth on the scale of the inverse photon mass. Expansion in powers of derivatives can be in principle performed and it will give corrections to the action on scales comparable to M_γ^{-1} . However, for our

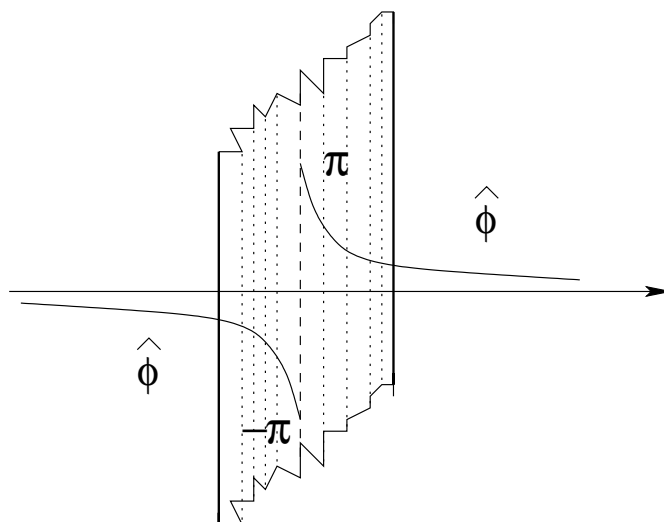

Figure 2: Schematic representation of the solution profile of the $\hat{\phi}$ field with a “rough” domain wall profile.

confining string strange things happen in the ultraviolet. Physically the situation is quite peculiar, since the action of the string has absolutely no sensitivity to the changes of the world-sheet on short distance scales. This should be obvious from our derivation of the string action. Suppose that rather than taking $\eta = 1$ on an absolutely smooth surface, we make the surface look the same on the scale M_γ^{-1} but add to it some wiggles on a much shorter distance scale d , as in figure 2.

To calculate the action we have now to solve the classical equation for the field $\hat{\phi}$ with the new boundary condition — the surface of the discontinuity is wiggly. This new boundary condition changes the profile of the classical solution only within the thickness d of the old surface. However, since the action of the classical solution is in no way dominated by the region of space close to the discontinuity, the action of the new solution will be the same as that of the old solution with the accuracy dM_γ . Thus, all string configurations which differ from each other only on small resolution scales $d \ll M_\gamma^{-1}$ have with this accuracy the same energy!. The string is therefore extremely soft, in the sense that it tolerates any number of wiggles on short distance scale without cost in energy, figure 3. In particular, since the string tension for our string is much greater than the square of the photon mass, $\sigma/M_\gamma^2 = g^2/M_\gamma \gg 1$, fluctuations on the scale of the string tension are not penalised at all.



Figure 3: The solid line represents the actual *weak* string. The dashed lines mean the contours of the effective thick string.

We believe that this independence of the action on short wave length fluctuations is a dynamical manifestation of the so called zigzag symmetry introduced by

Polyakov [29]. Indeed, Polyakov notes that if a segment of a string goes back on itself, physically nothing has happened and so such a zigzag should not cost any action. This situation is an extreme example of a wiggle we have just discussed — a wiggle with infinite momentum. What happens physically, is that not only infinite momentum modes, but also finite but large momentum string modes do not cost energy.

The confining string is therefore very different from a weakly interacting string usually considered in the string theory. In the weakly interacting string momentum modes with momentum of order of the square root of the string tension carry energy which is of the same order. In the confining string on the other hand, these momentum modes do not carry energy at all. Thus, we do not expect the spectrum of the confining string to contain states with large spatial momentum (heavy string states with low angular momentum).⁴

In a somewhat perverse way, this softness of the “mathematical” string leads to rigidity of the physical string. The point is the following. As it is obvious from the previous discussion, the high momentum modes are in a sense “gauge” degrees of freedom. The action of any string configuration does not depend on them. Consider a calculation of some physical quantity O in the string path integral. If O itself does not depend on the string high momentum modes, the integration over these modes factors out. If on the other hand O does depend on them, then its average vanishes since their fluctuation in the path integral is completely random. This is absolutely analogous to the situation in gauge theories, where all observables must be gauge invariant, and for calculation of those the integration over the gauge modes always factors out, independently of the observable under consideration.

Thus, for all practical purposes, we should just exclude the high momentum string modes from the consideration altogether (“gauge fix” them to zero). For example when calculating the entropy of our string we should only take into account the states which are different on the course grained level with the course graining scale of order M_γ^{-1} . This means that our string is intrinsically “thick”. If we still want to describe this situation in terms of a thin string with the string tension σ , we must make the string rigid so that any bend on the scale smaller than M_γ^{-1} be suppressed. Thus, such a string theory must have a curvature term with the coefficient of order σ/M_γ^2 .

The derivative expansion for the confining string action has been discussed in the literature (see [32]) and references therein). It has in general the form

$$S = \int d^2\xi \sqrt{g} g^{ab} D_a \vec{x} (\sigma + s D^2 + \dots) D_b \vec{x}, \tag{2.9}$$

⁴Indeed, the states with high angular momentum may very well be absent too, due to the fact that a long string can decay into a $W^+ - W^-$ pair. Therefore, we believe that most of the string states will not appear in the spectrum of the Georgi-Glashow model contrary to belief expressed in [29].

where g and D_a are the determinant and the covariant derivative with respect to induced metric $g_{ab} = \partial_a \vec{x} \partial_b \vec{x}$ on the embedded world-sheet $\vec{x}(\xi_1, \xi_2)$. The rigidity is controlled by the second term. In the derivative expansion the stiffness s is negative, and the system is stabilised by the higher order terms. Our argument shows that the cumulative effect of (the infinite number of) the higher order terms at short distances ($D \leq M_\gamma$) is equivalent to a large and positive curvature term

$$S = \int d^2 \xi \sqrt{g} g^{ab} D_a \vec{x} \left(\sigma + k \frac{\sigma}{M_\gamma^2} D^2 \right) D_b \vec{x} \tag{2.10}$$

with k a coefficient of order one. Hence in this way the fact that the confining string lacks real stringy high momentum degrees of freedom translates itself into large rigidity term in the effective description. We emphasise again that the rigidity is very large, and is effective on the distance scales much larger *parametrically* than the “natural” string scale given by the string tension.

2.3 The W^\pm bosons — the D0 branes of confining string

As discussed in [33] the deconfining phase transition in the Georgi-Glashow model is driven by the W^\pm bosons. It is therefore important to understand how they fit into the string picture.

The Polyakov effective lagrangian eq. (2.2) is only valid at energies much lower than M_W . This in principle does not preclude us from discussing W^\pm in its framework, since being charged particles they have a long range-low momentum field component associated with them, and this “Coulomb” field is in principle describable in the framework of eq. (2.2). We will not be able to describe the internal structure of W^\pm on the scale of their Compton wave length, but this is of no importance to us in any case. There is however one important element that we have to add to eq. (2.2) before the discussion of W^\pm can proceed.

As mentioned in the introduction, the Georgi-Glashow model possesses the global magnetic Z_2 symmetry. This symmetry in the confining phase is spontaneously broken in the vacuum [19, 20]. How is this Z_2 symmetry represented in the effective lagrangian eq. (2.2)? The answer is, that in fact the field ϕ does not take values in R , but is rather a phase. More precisely, the field χ , where

$$\phi = 2\chi \tag{2.11}$$

is the phase field which takes values between 0 and 2π . One can define a vortex operator [20]

$$V = \left(\frac{g^2}{8\pi^2} \right)^{1/2} \exp\{i\chi\}. \tag{2.12}$$

In terms of this operator the lagrangian eq. (2.2) is

$$S = \int dx^3 \left[\partial_\mu V \partial^\mu V^* - \frac{M_\gamma^2}{4} (V^2 + V^{*2}) \right]. \quad (2.13)$$

The magnetic Z_2 symmetry acts as $V \rightarrow -V$.

Since the field χ is a phase, it is obvious that the effective theory eq. (2.13) allows topologically nontrivial configurations with non-vanishing winding of χ . This is precisely how the W^\pm bosons are represented in this effective theory. According to [19, 20], the electric current is identified with the topological current in eq. (2.13),

$$\frac{g}{\pi} J_\mu = i\epsilon_{\mu\nu\lambda} \partial_\nu (V^* \partial_\lambda V). \quad (2.14)$$

Thus, charged states carry unit winding number of χ . The W^+ (W^-) boson is a state with positive (negative) unit winding of χ . The action also has to be augmented by a higher derivative term in order that the winding configuration has the “core” energy equal to M_W . By core energy we mean the energy concentrated at distances of order of the UV cutoff of our effective theory which is not contained in the low momentum field χ . This higher derivative term is

$$\delta S = \int d^3x \frac{1}{g^4 M_W} (\epsilon_{\mu\nu\lambda} \partial_\nu V^* \partial_\lambda V)^2. \quad (2.15)$$

The density of this action does not vanish only at the points where the phase of V is singular — that is the points of winding. For a closed curve C of length L which carries the winding, the contribution of this extra term to the action is $M_W L$, which is precisely the action of the world-line of a massive particle of mass M_W .

To represent a W boson in the string language, let us consider a path integral in the presence of one such particle. To create a winding state with world-line C we should insert a source in the path integral which forces a winding on the field χ . In terms of the field ϕ that would mean that it has to change by a 4π when going around C . The relevant partition function is

$$Z[C] = \int D\phi \exp \left\{ - \int dx^3 \left[\frac{g^2}{32\pi^2} (\partial_\mu \phi - 2\pi j_\mu(x)) (\partial^\mu \phi - 2\pi j^\mu(x)) + \frac{M_\gamma^2 g^2}{16\pi^2} (1 - \cos \phi) \right] - M_W L \right\}. \quad (2.16)$$

Here the “external current” j_μ is

$$j_\mu(x) = n_\mu^1(x) \delta(x \in S_1) + n_\mu^2(x) \delta(x \in S_2), \quad (2.17)$$

where S_1 and S_2 are two surfaces which both terminate on the curve C , and the unit vectors n^1 and n^2 are the normal vectors to these surfaces. The shape of the surfaces on which the current j_μ does not vanish is illustrated on Fig.4.

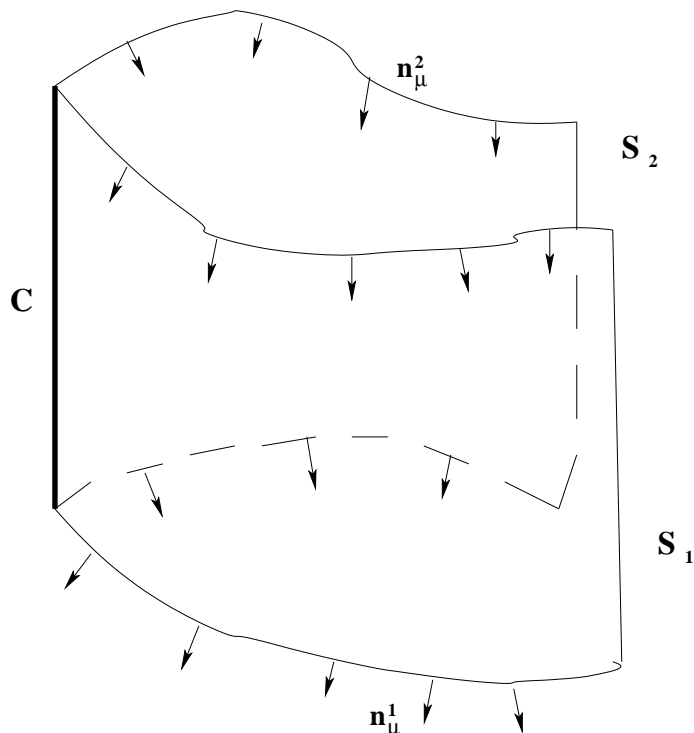

Figure 4: The two surfaces S_1 and S_2 along which the current j_μ is non-vanishing. The surfaces come together at the line C which is the world-line of the W boson.

The insertion of j_μ forces the field ϕ to jump across the surface S_1 by 2π and again jump by 2π across S_2 in order to cancel the, otherwise UV divergent contribution of j_μ . Thus when going around C the field ϕ changes by 4π and therefore C is the world-line of the W^+ boson.⁵

As before, splitting the field variable ϕ into $\hat{\phi}$ and η we see that the presence of j_μ just shifts the variable η by one on the two surfaces S_1 and S_2 . The integration over $\hat{\phi}$ at fixed η is performed in exactly the same way as before. The only difference now is that for any given η one has two extra string world-sheets along S_1 and S_2 .⁶ We thus see that the field theoretical path integral in the presence of a W^+ boson, in the string representation is given by the sum over surfaces in the presence of a D0 brane, which serves as a source for two extra string world-sheets. Usually D0 branes are thought of as infinitely heavy. The situation in the GG model is very similar in this respect. They are not infinitely heavy, but very heavy indeed since the mass of W is large on all scales relevant to zero temperature physics. The contribution of the

⁵We note that the position of the surfaces S_1 and S_2 is arbitrary as long as they both terminate on C . In particular they could coincide, which is the form used in [33]. Here we prefer to use a more general form with non coincident surfaces for reasons which will become clear immediately.

⁶We again stress that after the integration over η the result will not depend on exact position of S_1 and S_2 . However at fixed η the two surfaces introduced in eq. (2.17) specify the positions of the two extra world-sheets.

D0 brane to the partition function is suppressed by a very small factor $\exp\{-M_W L\}$, and vanishes for infinitely large system. As we will see in the next section however, the situation changes dramatically at finite temperature, where one dimension of the system has finite extent.

Incidentally, going back to our definition of the vortex field V , we see that in between the two world-sheets the value of V is negative, while outside them it is positive. Thus we have created domain of the second vacuum of V in between S_1 and S_2 . It may be easier to visualise the situation with both W^+ and W^- present. In this case the surfaces S_1 and S_2 terminate on one side on the world-line of W^+ , and on the other side on the world-line of W^- see figure 5. They are thus boundaries of a closed domain of the second vacuum of the field V . In the infrared therefore our strings are nothing but the Ising domain walls, and the pair of D0-branes creates an Ising domain.

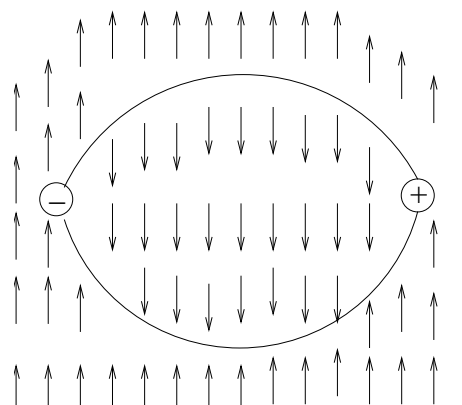

Figure 5: The Ising domain created by the two strings connecting the positions of W^+ and W^- particles. For static particles the configuration propagates in the time direction, perpendicular to the plane of the page.

Note, that in physical terms there are only two distinct vacua in the model $\langle V \rangle = 1$ and $\langle V \rangle = -1$. Thus having two domain walls is the same as having a wall and an anti-wall, and if they coincide spatially such a configuration is equivalent to the vacuum. A configuration of η with $\eta = 2$ on a closed surface is physically equivalent to vacuum. Therefore the values that η is allowed to take are limited to 0,1 and -1 .

We close this section by noting, that the reason we have two string world-sheets terminating on a D0 brane is that the field theory in question has only fields in adjoint representation of $SU(2)$. We can imagine adding heavy fundamental particles to the model. We would then have also allowed configurations of one string world-sheet terminating on a D0 brane. These D0 branes would however be physically different and would have a different mass and therefore a different weight in the path integral. In the field theoretic terms, presence of the fundamental charges changes drastically the properties of the Z_2 magnetic symmetry, turning it into a local rather than a global symmetry [35].

3. How does the string melt?

Now that we have an understanding of the basic physical properties of the confining string we can move on to the analysis of the deconfining phase transition. The question we want to address is what is the mechanism of the melting of the string in

the deconfined phase. In this respect the basic mechanism that has been discussed in the framework of the string theory is the Hagedorn transition, where the limiting temperature is reached due to excitations of the high energy spectrum of the string. It has also an interpretation as the BKT transition due to the condensation of the vortices on the string world-sheet.

In this section we will first explain how this mechanism is related to the well understood physics of deconfinement in the GG model. It turns out that the Hagedorn transition corresponds to “confinement” or binding of magnetic monopoles at high temperature. Then we show that the vortex on the world-sheet should be understood as the world-line of the end point of an open string. Thus the “condensation of vortices on the world-sheet” is the statement that once the monopoles are bound, and there is no linear potential between charges any longer, the thermal ensemble contains arbitrarily long strings. If open strings exist in the theory as dynamical objects, they appear in the thermal ensemble (world-sheet vortices). If only closed strings are allowed, as is the case in the GG model, the thermal ensemble is dominated by closed strings of arbitrary length. World lines of charged particles also map into world-sheet vortices in the string description, although these vortices are slightly different. The presence of arbitrarily long strings would mean deconfinement of charges, or “plasma phase” also of these vortices.

Although such a mechanism of transition is a logical possibility, it turns out that the actual mechanism in the Georgi-Glashow model is completely different. Due to the thickness of the physical string, the transition happens long before the “Hagedorn temperature”. It occurs because the density of charged particles (D0 branes) becomes large enough, so that the distance between them becomes smaller than the width of the string. So the thermal ensemble is dominated by configurations in which the length of the strings is shorter than their thickness. At this point of course the string picture becomes useless. The theory really becomes the plasma of weakly interacting D0-branes. This destruction of the string “from within” is quite peculiar from the string point of view. In a sense it is of distinctly field theoretical nature, rather than a string theoretical nature. It occurs due to physics on the scale smaller than the string thickness, where as we have seen the string language is inadequate, since no string modes exist at these momenta.

3.1 Deconfinement in the Georgi-Glashow model

We start with a brief recap of the main points of [33]. Within the GG model there are two mechanism for the deconfining transition that one can contemplate.

The first one is the binding of magnetic monopoles at high temperature. This mechanism was first suggested in [36]. The point here is the following. In the euclidean path integral formalism the monopoles form Coulomb gas with the interaction “potential” decreasing as $1/r$ at large distances. However, at finite temperature the interaction in the infrared becomes logarithmic. The reason is that the finite temper-

ature path integral is formulated with periodic boundary conditions in the Euclidean time direction. The field lines are therefore prevented from crossing the boundary in this direction. The magnetic field lines emanating from the monopole have to bend close to the boundary and go parallel to it. So, effectively the whole magnetic flux is squeezed into two dimensions. The length of the time direction is $\beta = 1/T$, and thus clearly the field profile is two dimensional on distance scales larger than β . Two monopoles separated by a distance larger than β therefore interact via a two dimensional rather than a three dimensional Coulomb potential, which is logarithmic at large distances. Since the density of the monopoles is tiny $\rho_M \propto M_\gamma^2$, already at extremely low temperatures $T \propto M_\gamma$ the monopole gas becomes two dimensional. The strength of the logarithmic interaction is easily calculated. The magnetic flux of the monopole far enough from the core spreads evenly in the compact direction. The field strength should have only components parallel to the spatial directions. Since the total flux of the monopole is $2\pi/g$, the field strength far from the core is $\vec{F}_i = \frac{T}{g} \frac{x_i}{x^2}$, and thus the strength of the infrared logarithmic interaction is T^2/g^2 .

Two dimensional Coulomb gas is known to undergo the BKT phase transition. Due to the peculiar property that for the monopoles the strength of the logarithmic interaction grows with temperature, the high temperature phase corresponds to the monopole binding phase. The transition temperature above which the monopoles are bound is

$$T_{MB} = \frac{g^2}{2\pi}. \tag{3.1}$$

Below this temperature the photon should be massive, while above this temperature it should be massless since the cosine term in the lagrangian eq. (2.2) is irrelevant. Thus one may expect the deconfining transition at $T = g^2/2\pi$ which is in the universality class of 2D XY model.

The other candidate mechanism is the appearance of the charged plasma of W^\pm . If one neglects the monopole effects and considers a “non-compact” theory, the potential between charged particles is logarithmic. At finite temperature one has a certain, albeit very small density of W 's. Thus the system again resembles a two dimensional Coulomb gas. This gas undergoes a BKT transition from a confined phase to a plasma phase at $T_{NC} = g^2/8\pi$. If this were the mechanism of the transition, the universality class would be again that of 2D XY model.

The truth however lies somewhere in between [33]. It turns out that at T_{NC} the density of W 's is very small, so that the transition does not occur since the charges are bound by the linear potential. However at $T_C = g^2/4\pi$ the mean distance between W^\pm in the ensemble becomes equal to the thickness of the confining string. At this point it does not make sense any more to think of the thermal ensemble as dilute gas of W^\pm pairs bound by strings, but the ensemble rather looks like a neutral plasma. Indeed it is shown rigorously in [33] that the transition occurs at T_C . The universality class of the transition is that of the 2D Ising model corresponding to the restoration

of the magnetic Z_2 symmetry. The transition can be pictured as condensation of Ising domains which fill the interior of W^+ - W^- bound states.

3.2 The monopole binding as the Hagedorn transition

Let us now consider the phase transition from the string perspective. First, in analogy with the discussion in the previous subsection, let us completely disregard the charged particles. From the string point of view this means that we neglect possible contributions of the heavy D0 branes, and thus are entirely within the theory of closed strings. Naively one expects in such a theory existence of Hagedorn temperature, beyond which the string can not exist. In an almost free string this temperature is of order of the string scale. One can visualise this phenomenon in simple terms. Consider a closed string of a given fixed length L . Let us calculate the free energy of such a string. The energy of the string is

$$E = \sigma L. \tag{3.2}$$

The number of states for a closed string of the length L scales exponentially with L

$$N(L) = \exp\{\alpha L\}. \tag{3.3}$$

The dimensional constant α is determined by the physical thickness of the string. Imagine that the string can take only positions allowed on a lattice with the lattice spacing a . Then clearly the number of possible states is $z^a L$, where z is the number of order one, equal to the number of nearest neighbours on the lattice.⁷ In this simple situation $\alpha = a \ln z$. The only natural lattice spacing for such a discretization is the thickness of the string. For an almost free string the thickness is naturally the same as the scale associated with the string tension. Thus the entropy is

$$x\sqrt{\sigma}L, \tag{3.4}$$

with x a number of order one. The free energy then is

$$F[L] = \sigma L - xT\sqrt{\sigma}L. \tag{3.5}$$

At the temperature

$$T_H = \frac{1}{x}\sqrt{\sigma} \tag{3.6}$$

the free energy becomes negative, which means that strings of arbitrary length appear in the thermal ensemble in a completely unsuppressed way. The thermal vacuum becomes a “soup” of arbitrarily long strings. Thus, effectively the “temperature dependent” string tension vanishes and it is not possible to talk about strings anymore

⁷We disregard in this argument the fact that the string has to close on itself. This extra condition would lead to a prefactor with power dependence on L . Such a prefactor is not essential for our argument, and we therefore do not worry about it.

in the hot phase. For more details about this “random walk” description of hot strings see [37] and references therein.

The situation is very similar to the BKT phase transition, where the free energy of a vortex becomes negative at the critical temperature, and the vortices populate the vacuum in the hot phase.

In the string partition function language this is just a restatement of the well known fact that the partition function diverges in the sector with the topology of a torus which winds around the compact Euclidean time direction. Fixing the unit winding in the Euclidean time physically corresponds to the calculation of the free energy in the sector with one closed string. The integration over all possible lengths of the string is the cause of the divergence of the partition function at high temperature.

The same physical effect is there for the confining GG string. There is one difference, which however turns out to be crucial for the nature of the phase transition. The thickness of the GG string is not given by the string tension. Rather it is equal to the inverse photon mass, and thus

$$\alpha \propto M_\gamma \propto \frac{\sigma}{g^2}. \tag{3.7}$$

We thus have for the confining GG string

$$T_H = \frac{\sigma}{\alpha} \propto g^2. \tag{3.8}$$

This is indeed the correct magnitude of the critical temperature as discussed in the previous subsection.

The noteworthy feature of this formula is, that the Hagedorn temperature of the confining string is much higher than the string scale. This is easy to understand because the entropy of the thick string is much smaller than that of the free string due to the fact that high momentum modes of the confining string do not contribute to the entropy at all, as discussed in the previous section. Thus, one needs to heat the string to a much higher temperature for entropy effects to become important.

Since we have completely neglected the possibility of appearance of D0 branes (charged particles), the transition we have been discussing is the string representation of the monopole binding transition in the Georgi Glashow model. At the point where the monopoles bind, the photon of the GG model becomes massless and thus the string tension disappears and the thickness of the string diverges. In the Hagedorn picture this is just the dual statement that the ensemble is dominated by the infinitely long strings. The BKT nature of both transitions underlines this point.

3.3 Vortices on the world-sheet — open strings and charged particles

Sometimes the Hagedorn transition is discussed in terms of the vortices on the world-sheet. What is the physical nature of these objects?

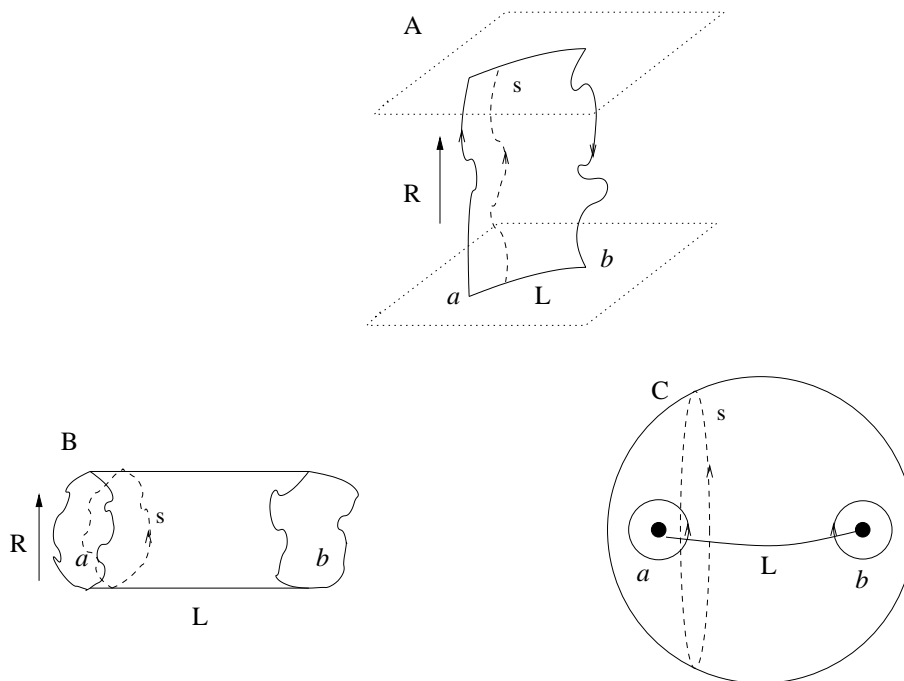

Figure 6: The open string world-sheet conformally transformed into a closed string world-sheet with a vortex-anti-vortex pair. L is the length of the string, a and b are locations of the vortex and the anti-vortex on the world-sheet and R represents the compact dimension.

Consider a string world-sheet with the topology of a sphere with a vortex-anti-vortex pair. When going around the vortex location on the world-sheet, the compact coordinate x_0 varies from 0 to β . Since this is true for any contour of arbitrarily small radius, which encircles the vortex, this means that physically the location of the vortex in fact corresponds in the target space not to a point but rather to a line which winds around the compact direction. The vortex-anti-vortex pair on the world-sheet thus represents an *open* string which winds around the compact direction. Figure 6 illustrates how the open string world-sheet, equivalent to a cylinder is transformed by a conformal transformation into a sphere with two singular points — the vortex-anti-vortex pair.

If the string theory in question does have an open string sector, the configurations with arbitrary number of vortex-anti-vortex pairs contribute to the finite temperature partition function. The Hagedorn transition then can be discussed in this sector rather than in the closed string sector. Not surprisingly, the discussion is exactly the same as in the previous subsection. The fact that we now have an open rather than closed string does not change the entropy versus energy argument. One finds then that at $T < T_H$ the vortices on the world-sheet are bound in pairs. The corresponding target space picture is that the "ends" of the open strings are bound by linear potential and therefore long open strings do not contribute to the thermal ensemble. In exactly the same way, long closed strings are also absent from the ensemble. At

$T > T_H$ the vortices unbind and appear in the ensemble as the Coulomb gas. Thus a typical configuration contains lots of open strings (as well as lots of arbitrarily long closed strings) since the energy of such strings is overwhelmed by the entropy.

Note however, that the existence of the transition in this context is entirely independent of the presence or absence of the vortices. As we saw above, the transition can be understood purely on the level of the closed string. It is driven by the string fluctuations. Thus, even if the theory does not have an open string sector, the transition is still there. For example there are no open strings in the Georgi Glashow model. Nevertheless, if we neglect the effects of W^\pm the Hagedorn transition is still there and it coincides with the "monopole binding" transition.

The actual phase transition in the Georgi-Glashow model is however not driven by monopole binding. In the string language nevertheless, it is also due to the proliferation of vortices on the world-sheet. Those are however vortices of a somewhat different type. The same conformal transformation that turned the open string boundary into a point can be used to turn into a point the world-line of a D0 brane. As discussed above, a (fundamentally) charged particle which couples to the GG confining string is indeed a D0 brane. Thus a string world-sheet representation of a pair of particles with opposite charge is also a vortex-anti-vortex pair on a sphere.⁸

There are some important differences between these vortices and the ones that represent the ends of the open string.

First, for an open string the non-compact "spatial" coordinates satisfy Neuman boundary conditions. Thus even as x^0 winds, the other coordinates x^i can take arbitrary values close to the vortex. One can see this from the action

$$S = \sigma \int d^2\xi \partial_a x^0 \partial_a x^0 + \sigma \int d^2\xi \partial_a x^i \partial_a x^i, \tag{3.9}$$

where the dynamics of x^i sector is absolutely unrelated to the dynamics of x^0 . Thus even though a vortex in x^0 sector can be considered as a boundary in the target space, the boundary conditions for the components x^i are free. In other words there is no boundary action induced by vortices in a theory of closed strings. For a very heavy D0 brane on the other hand the boundary conditions are of the Dirichlet type. Thus x_i 's are constant close enough to the vortex location. If the mass of a D0 brane is finite, there is a nontrivial boundary action describing a massive particle. In that case one has non-conformal boundary conditions compatible with the finite mass of the D0 brane [38].

Another difference, is that since the D0 brane is an independent degree of freedom, in principle its mass is a free parameter. Thus the fugacity of the D0 brane vortex is an independent parameter, and the contribution of such a vortex to the

⁸We note that the name "vortex" is particularly apt in this case, since the same charged particle, which generates the vortex on the world-sheet, is also a vortex of the dual photon field ϕ in the Polyakov's effective theory eq. (2.2) as discussed in the previous section.

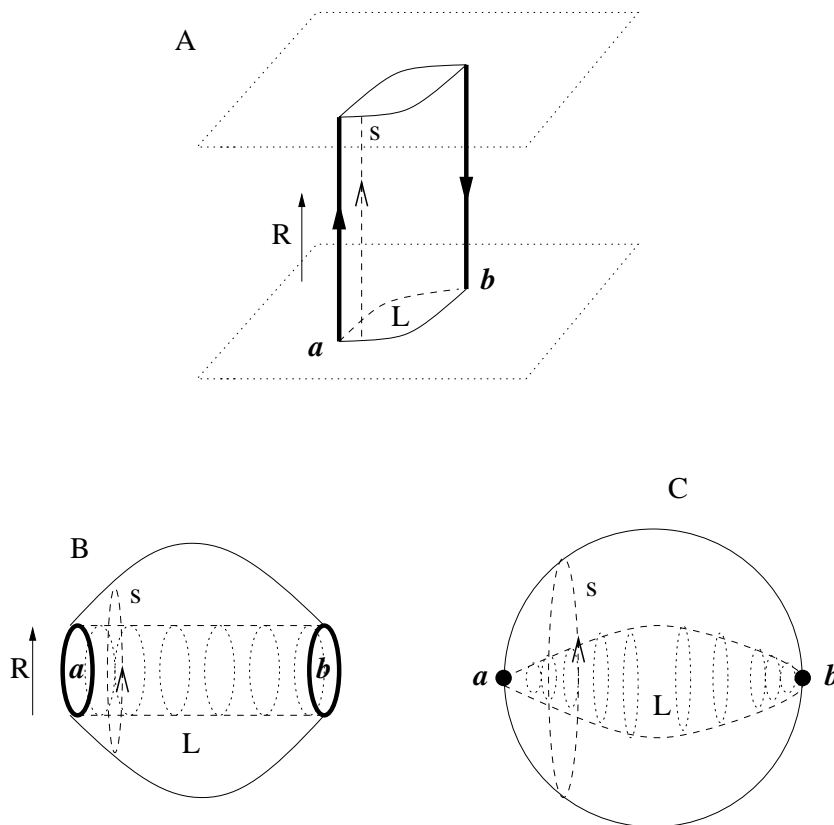

Figure 7: The D0 brane-anti-brane ($W^+ - W^-$) pair with two strings connecting them conformally transformed into a string world-sheet with two “double vortices”.

thermal ensemble is determined by this fugacity. The thermal physics may depend on this extra parameter.

To get back to the theory at hand, the Georgi-Glashow confining string has neither an open string sector nor D0 branes which are sources of a single string. The dynamical objects which couple to the string are the charged W^\pm particles, which have an adjoint charge and therefore are sources of a pair of strings.

3.4 D0 branes destroy the string

Each D0 brane has two strings emanating from it. Thus a pair of branes propagating in compact imaginary time is conformally equivalent to a pair of “double vortices” as in figure 7. The singular points are still vortices as before, since going around such point one travels once around the compact time direction. But now two string world-sheets are permanently glued together at the location of a vortex. The fact that two world-sheets are glued at the location of the vortex is the manifestation of the Z_2 magnetic symmetry of the GG model. The region of space between the two world-sheets is separated from the region of space on the outside, reflecting the fact that it constitutes a domain of a different vacuum.

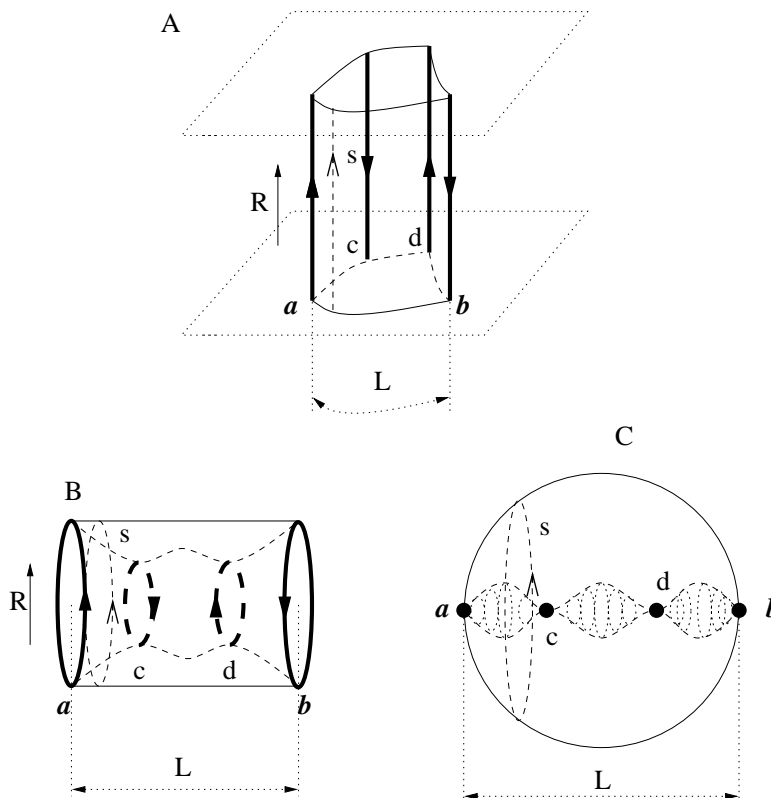

Figure 8: Four branes connected by strings. Such configurations become important above the transition.

At low temperatures such configurations in the thermal ensemble are rare. But at the critical temperature their density becomes so large that the ensemble is dominated by multi-vortex configurations. In the string picture those are configurations with multiple points of “gluing”. Importantly the D0 branes are not just pairwise connected by two strings, but rather form a network where all of them are connected to each others. Clearly entropy wise such configurations are much more favourable, and there is also no loss of energy when the distance between the D0 branes is of the order of the string thickness. As an example we show in Fig.8 a configuration with four mutually connected D0 branes.

This string-based description of the transition has to be taken with a grain of salt. The relevant physics takes place on short distance scales — of the order of the thickness of the string. On these scales, as we explained above, the string modes are practically absent. Thus even though we have showed the string segments on figure 8, these segments are so short that there is no string tension associated with them. Thus the mechanism of the transition is essentially field theoretical rather than string theoretical.

To understand this point better consider in a little more detail the thermal ensemble of W^\pm . The crucial point is that at distance scales $d \ll M_\gamma^{-1}$ the interaction

between them is Coulomb rather than linear. The gas of charges with Coulomb interaction has itself a transition into plasma phase. This transition has nothing to do with the long range linear interaction and occurs at the temperature T_{NC} which is four times smaller than the Hagedorn temperature as discussed in [33, subsection 3.1]. At this temperature W^\pm become "free" in the sense that they cease to care about the Coulomb part of the potential. The crucial question however is how large is the density of W^\pm at this point. If the density at T_{NC} were large and the average distance between W 's were smaller than M_γ^{-1} , the transition would actually occur at T_{NC} , since the long range linear part of the potential would be entirely irrelevant. As it happens, in the GG model this is not the case, and the density of W 's is small. Thus at T_{NC} there is a certain rearrangement of the thermal ensemble on short distance scale, but at long distances nothing happens — the string still confines. However, at $T_C = T_H/2$ the density of W reaches the critical value and the transition occurs. Note that at this temperature the large length fluctuations of the string are still suppressed — we are far below the Hagedorn temperature. The string is destroyed not due to "stringy" physics of the Hagedorn transition, but due to the short distance field theoretical effects: the fact that fugacity of W is relatively large and that the interaction at short distances is Coulomb and not linear.

4. Discussion

Let us summarise the discussion of the two previous sections. The confining string in the Georgi-Glashow model is thick. Its physical thickness is much larger than the square root of the inverse string tension. Physics on the distance scales smaller than the thickness of the string is essentially field theoretical, since the high momentum string degrees do not contribute. The heavy W -bosons behave like D0 branes — they are sources of a pair of confining strings.

At high temperature the appearance of the W — bosons, D0 branes in the thermal ensemble is understood in the world-sheet picture as appearance of vortices and anti-vortices on the world-sheet. The density of these vortices is governed by the fugacity of the W — bosons. When the distance between the branes becomes equal to the thickness of the string, the transition occurs. The thermal ensemble above the transition is dominated by states with large numbers of D0 branes, connected to each other by short segments of the string. Talking about segments of string in these circumstances is really only a mnemonic, since the confining string does not have any modes at momenta corresponding to the inverse length of those strings. Thus, the string world-sheet disappears. The string disintegrates into D0 branes. The transition has nothing to do with the Hagedorn transition, which corresponds to appearance of arbitrarily long strings (closed or open). Thus the deconfining transition occurs at the temperature lower than the Hagedorn temperature of the confining string.

One lesson that we learn from this, is that the UV structure of the string is extremely important. In this particular case, the ultraviolet sector contains D0 branes, and at high enough temperature they dominate physics, thus superseding the stringy transition mechanism.

How universal is this situation?. Does deconfinement always precede Hagedorn?. It is hard to tell. Naively one could think, that since the mass of the D0 brane is a free parameter, it can be made arbitrarily large. Thus, one could have a situation that at the Hagedorn temperature the density of D0 branes is still small, and the string remains intact all the way up to T_H . If that were the case, the Hagedorn transition would indeed be realized. However, within the GG model the mass of the W boson is not free, once the string tension and the width of the string are fixed. Making W heavier also makes the string thicker, and this conspiracy always leads to marginalization of the Hagedorn transition, at least as long as the coupling is weak. In the strong coupling limit (light W) things may be different. Strong coupling corresponds to the pure Yang Mills theory. In this case, at least at large N the spectrum is believed to be much closer to a stringy spectrum [39]. So perhaps the Hagedorn transition takes over. On the other hand, even at large N the confining string has a finite thickness. The analog of the W mass — half the mass of a glueball — is also finite. Thus, even in the large N limit there is no parameter which would tell us that the D0 brane mechanism is irrelevant.

In fact, universality arguments suggest that the D0 brane condensation mechanism prevails all the way to strong coupling. The transition in the SU(2) gauge theory is supposedly in the Ising universality class, just like in the Georgi-Glashow model. On the other hand the Hagedorn transition is the BKT transition and is thus in the XY universality class. It seems therefore that at least in the SU(2) case the deconfining transition is not of the Hagedorn type. For larger N one can show that the transition in the weakly coupled limit is again second order and is not in the universality class of U(1) [40]. The Hagedorn transition is again of the U(1) type. By the usual universality prejudice, we expect the weak and strong coupling regimes to be in the same universality class. If that is the case, here the Hagedorn transition does not win either. The situation however can be different in other dimensionalities, and our analysis has nothing to say about that.

The explicit solution of the Georgi-Glashow model does provide interesting examples of phenomena discussed in the framework of the string theory. We saw how the open strings and D0 branes realize the vortices on the world-sheet. The D0 branes we dealt with have two strings attached to them. In SU(N) theories each D0 brane would have N strings, and the corresponding vortex would have N string world-sheets glued at its location. We have understood the connection between the Hagedorn transition and the binding of magnetic monopoles. Finally, we have seen how the string is destroyed by the condensation of D0 branes.

We hope that the simple but nontrivial physics discussed here will eventually be of help in the attempts to understand hot string theory.

Acknowledgments

The work of I.K. was supported by PPARC Grant PPA/G/O/1998/00567. The research of A.K. was supported by PPARC. M.S. has been supported by CONICET of Argentina, Fundación Antorchas of Argentina and The British Council.

References

- [1] R. Hagedorn, *Statistical thermodynamics of strong interactions at high-energies*, *Nuovo Cim. Suppl.*, **3** (1965) 147.
- [2] S. Fubini and G. Veneziano, *Level structure of dual resonance models*, *Nuovo Cim.* **A64** (1969) 1640;
K. Huang and S. Weinberg, *Ultimate temperature and the early universe*, *Phys. Rev. Lett.* **25** (1970) 895.
- [3] S. Frautschi, *Statistical bootstrap model of hadrons*, *Phys. Rev.* **D 3** (1971) 2821;
R.D. Carlitz, *Hadronic matter at high density*, *Phys. Rev.* **D 5** (1972) 3231.
- [4] N. Cabibbo and G. Parisi, *Exponential hadronic spectrum and quark liberation*, *Phys. Lett.* **B 59** (1975) 67.
- [5] J. Polchinski, *String theory*, vol 1,2. (CUP) 1998.
- [6] S.A. Abel, J.L. F. Barbon, I.I. Kogan and E. Rabinovici, *Some thermodynamical aspects of string theory*, hep-th/9911004.
- [7] V.L. Berezinsky, *Destruction of long range order in one-dimensional and two-dimensional systems having a continuous symmetry group. 1. classical systems*, *Sov. Phys. JETP* **32** (1971) 493.
- [8] J.M. Kosterlitz, D.J. Thouless, *Ordering, metastability and phase transitions in two-dimensional systems*, *J. Phys.*, **C 6** (1973) 1181.
- [9] I.I. Kogan, *Vortices on the world sheet and string's critical dynamics*, *Sov. Phys. JETP Lett.* **45** (1987) 709, *Pisma Zh. Eksp. Teor. Fiz.*, **45** (1987) 556.
- [10] B. Sathiapalan, *Vortices on the string world sheet and constraints on toral compactification*, *Phys. Rev.* **D 35** (1987) 3277.
- [11] J.J. Atick and E. Witten, *The hagedorn transition and the number of degrees of freedom of string theory*, *Nucl. Phys.* **B 310** (1988) 291.
- [12] J.A. A. Abrikosov and Y.I. Kogan, *Vortices on the string and superstring world sheets*, *Int. J. Mod. Phys.* **A 6** (1991) 1501.

- [13] S.S. Gubser, S. Gukov, I.R. Klebanov, M. Rangamani and E. Witten, *The hagedorn transition in non-commutative open string theory*, hep-th/0009140.
- [14] I. Antoniadis and C. Kounnas, *Superstring phase transition at high temperature*, *Phys. Lett. B* **261** (1991) 369;
 I. Antoniadis, J.P. Derendinger and C. Kounnas, *Non-perturbative temperature instabilities in $N = 4$ strings*, *Nucl. Phys. B* **551** (1999) 41 [hep-th/9902032];
 I. Bakas, A. Bilal, J.P. Derendinger and K. Sfetsos, *BPS solutions and new phases of finite-temperature strings*, *Nucl. Phys. B* **593** (2001) 31 [hep-th/0006222];
 K. Sfetsos, *Supersymmetric phases of finite-temperature strings. II*, *J. High Energy Phys.* **11** (2000) 005 [hep-th/0008025].
- [15] N. Deo, S. Jain and C.-I. Tan, *Strings at high-energy densities and complex temperature*, *Phys. Lett. B* **220** (1989) 125; *String statistical mechanics above Hagedorn energy density*, *Phys. Rev. D* **40** (1989) 2626;
 N. Deo, S. Jain, O. Narayan and C.-I. Tan, *The effect of topology on the thermodynamic limit for a string gas*, *Phys. Rev. D* **45** (1992) 3641.
- [16] B. Sathiapalan, *The hagedorn transition and the matrix model for strings*, *Mod. Phys. Lett. A* **13** (1998) 2085 [hep-th/9805126].
- [17] J. Ambjorn, Y.M. Makeenko and G.W. Semenoff, *Thermodynamics of D0-branes in matrix theory*, *Phys. Lett. B* **445** (1999) 307 [hep-th/9810170];
 J.P. Penalba, *Non-perturbative thermodynamics in matrix string theory*, *Nucl. Phys. B* **556** (1999) 152 [hep-th/9904094];
 S. Bal and B. Sathiapalan, *High temperature limit of the $N = 2$ IIA matrix model*, *Nucl. Phys. 94 (Proc. Suppl.)* (2001) 693 [hep-lat/0011039].
- [18] A.M. Polyakov, *Thermal properties of gauge fields and quark liberation*, *Phys. Lett. B* **72** (1978) 477;
 L. Susskind, *Lattice models of quark confinement at high temperature*, *Phys. Rev. D* **20** (1979) 2610.
- [19] G.'t Hooft, *On the phase transition towards permanent quark confinement*, *Nucl. Phys. B* **138** (1978) 1;
 S. Samuel, *The grand partition function in field theory with applications to sine-Gordon*, *Phys. Rev. D* **18** (1978) 1916;
 A. Kovner and B. Rosenstein, *Topological interpretation of electric charge, duality and confinement in $(2 + 1)$ -dimensions*, *Int. J. Mod. Phys. A* **7** (1992) 7419; *Strings and string breaking in $(2 + 1)$ dimensional nonabelian theories*, *J. High Energy Phys.* **09** (1998) 003 [hep-th/9808031];
 For a recent review see A. Kovner, *Confinement, magnetic $Z(N)$ symmetry and low energy effective theory of gluodynamics*, hep-ph/0009138.
- [20] C. Korthals-Altes, A. Kovner and M. Stephanov, *Spatial't Hooft loop, hot QCD and $Z(N)$ domain walls*, *Phys. Lett. B* **469** (1999) 205 [hep-ph/9909516];

- C. Korthals-Altes and A. Kovner, *Magnetic $Z(N)$ symmetry in hot QCD and the spatial wilson loop*, *Phys. Rev. D* **62** (2000) 096008 [[hep-ph/0004052](#)].
- [21] G. 't Hooft, *A planar diagram theory for strong interactions*, *Nucl. Phys. B* **72** (1974) 461.
- [22] J. Maldacena, *The large- N limit of superconformal field theories and supergravity*, *Adv. Theor. Math. Phys.* **2** (1998) 231 [[hep-th/9711200](#)];
 S.S. Gubser, I.R. Klebanov and A.M. Polyakov, *Gauge theory correlators from non-critical string theory*, *Phys. Lett. B* **428** (1998) 105 [[hep-th/9802109](#)];
 E. Witten, *Anti-de Sitter space and holography*, *Adv. Theor. Math. Phys.* **2** (1998) 253 [[hep-th/9802150](#)].
- [23] J. Polchinski, *High temperature limit of the confining phase*, *Phys. Rev. Lett.* **68** (1992) 1267 [[hep-th/9109007](#)].
- [24] S.K. Rama and B. Sathiapalan, *The hagedorn transition, deconfinement and the AdS/CFT correspondence*, *Mod. Phys. Lett. A* **13** (1998) 3137 [[hep-th/9810069](#)].
- [25] J.L. F. Barbon, I.I. Kogan and E. Rabinovici, *On stringy thresholds in SYM/AdS thermodynamics*, *Nucl. Phys. B* **544** (1999) 104 [[hep-th/9809033](#)].
- [26] C.B. Thorn, *Infinite $N(C)$ QCD at finite temperature: is there an ultimate temperature?*, *Phys. Lett. B* **99** (1981) 458.
- [27] A.M. Polyakov, *Compact gauge fields and the infrared catastrophe*, *Phys. Lett. B* **59** (1975) 82.
- [28] A.M. Polyakov, *Quark confinement and topology of gauge groups*, *Nucl. Phys. B* **120** (1977) 429.
- [29] A.M. Polyakov, *Confining strings*, *Nucl. Phys. B* **486** (1997) 23 [[hep-th/9607049](#)].
- [30] M.C. Diamantini, F. Quevedo and C.A. Trugenberger, *Confining strings with topological term*, *Phys. Lett. B* **396** (1997) 115 [[hep-th/9612103](#)];
 D.V. Antonov, *Gluodynamics string as a low-energy limit of the universal confining string theory*, *Phys. Lett. B* **427** (1998) 274 [[hep-th/9804016](#)]; *Various properties of compact QED and confining strings*, *Phys. Lett. B* **428** (1998) 346 [[hep-th/9802056](#)].
- [31] A.M. Polyakov, *Fine structure of strings*, *Nucl. Phys. B* **268** (1986) 406;
 H. Kleinert, *The membrane properties of condensing strings*, *Phys. Lett. B* **174** (1986) 335.
- [32] M.C. Diamantini, H. Kleinert and C.A. Trugenberger, *Universality class of confining strings*, *Phys. Lett. B* **457** (1999) 87 [[hep-th/9903208](#)].
- [33] G. Dunne, I.I. Kogan, A. Kovner and B. Tekin, *Deconfining phase transition in 2+1D: the georgi-glashow model*, *J. High Energy Phys.* **01** (2001) 032 [[hep-th/0010201](#)].

- [34] V.I. Ogievetsky and I.V. Polubarinov, *The notoph and its possible interactions*, *Sov. J. Nucl. Phys.* **4** (1967) 156;
M. Kalb and P. Ramond, *Classical direct interstring action*, *Phys. Rev.* **D 9** (1974) 2273;
D.Z. Freedman and P.K. Townsend, *Antisymmetric tensor gauge theories and nonlinear sigma models*, *Nucl. Phys.* **B 177** (1981) 282.
- [35] C.D. Fosco and A. Kovner, *Vortices and bags in 2 + 1 dimensions*, *Phys. Rev.* **D 63** (2001) 045009 [[hep-th/0010064](#)].
- [36] N.O. Agasian and K. Zarembo, *Phase structure and nonperturbative states in three-dimensional adjoint Higgs model*, *Phys. Rev.* **D 57** (1998) 2475 [[hep-th/9708030](#)].
- [37] D.A. Lowe and L. Thorlacius, *Hot string soup*, *Phys. Rev.* **D 51** (1995) 665 [[hep-th/9408134](#)];
S. Abel, K. Freese, I. I.Kogan, *Hagedorn inflation of D-branes*, *J. High Energy Phys.* **01** (2001) 039, [hep-th/0005028](#).
- [38] I.I. Kogan, J.F. Wheeler, *ND tadpoles as new string states and quantum mechanical particle-wave duality from world-sheet T-duality*, *Phys. Lett.* **B 403** (1997) 31, [hep-th/9703141](#).
- [39] R.W. Johnson and M.J. Teper, *String models of glueballs and the spectrum of SU(n) gauge theories in 2 + 1 dimensions*, [hep-ph/0012287](#).
- [40] I. Kogan, A. Kovner and B. Tekin, in preparation.