

EUROPEAN ORGANIZATION FOR NUCLEAR RESEARCH
European Laboratory for Particle Physics*Large Hadron Collider Project***LHC Project Report 416****THE ELECTRICAL DISTRIBUTION FEED BOX
FOR THE LHC PROTOTYPE CELL**C. Hauviller¹, P.M. Ivanov², A. Poncet¹, P. Sacré¹ and P. Trilhe¹**Abstract**

The Electrical Distribution Feed Box (DFB) for the Large Hadron Collider (LHC) Prototype Cell (String 2) is a 6 meter-long 4.6 K / 0.135 MPa liquid helium cryostat which supports and cools 13 kA and 600 A High-Temperature Superconductor (HTS) current leads. These are used for powering the String 2 main dipole and quadrupole superconducting magnets, together with their correctors. The DFB also incorporates the 1-plate between its saturated liquid helium bath and the magnet pressurized superfluid helium bath at 1.9 K/ 0.13 MPa.

The DFB is built within the frame of a collaboration between CERN and the Budker Institute of Nuclear Physics (Novosibirsk, Russian Federation). It is a complex cryostat satisfying a number of constraints (space available, accessibility, integration) and combining different technologies such as mechanical and electrical engineering, superconductivity, cryogenics and vacuum.

The current status of the design and construction of the DFB for the LHC Prototype Cell, together with an outlook towards the LHC arc DFB's, is given.

1 CERN, LHC Division, Geneva, Switzerland

2 Budker Institute of Nuclear Physics, Novosibirsk, Russian Federation. Member of the CERN-Russia Collaboration to the LHC

Presented at the Seventh European Particle Accelerator Conference (EPAC 2000)
26-30 June 2000, Vienna, Austria

Administrative Secretariat
LHC Division
CERN
CH - 1211 Geneva 23
Switzerland

Geneva, 23 September 2000

The Electrical Distribution Feed Box for the LHC Prototype Cell

C. Hauviller, A. Poncet, P. Sacré, P. Trilhe, CERN, Geneva, Switzerland

P.M. Ivanov, Budker Institute of Nuclear Physics, Novosibirsk, Russian Federation

Abstract

The Electrical Distribution Feed Box (DFB) for the Large Hadron Collider (LHC) Prototype Cell (String 2) is a 6 meter-long 4.6 K / 0.135 MPa liquid helium cryostat which supports and cools 13 kA and 600 A High-Temperature Superconductor (HTS) current leads. These are used for powering the String 2 main dipole and quadrupole superconducting magnets, together with their correctors. The DFB also incorporates the λ -plate between its saturated liquid helium bath and the magnet pressurized superfluid helium bath at 1.9 K/0.13 MPa.

The DFB is built within the frame of a collaboration between CERN and the Budker Institute of Nuclear Physics (Novosibirsk, Russian Federation). It is a complex cryostat satisfying a number of constraints (space available, accessibility, integration) and combining different technologies such as mechanical and electrical engineering, superconductivity, cryogenics and vacuum.

The current status of the design and construction of the DFB for the LHC Prototype Cell, together with an outlook towards the LHC arc DFB's, is given.

1 INTRODUCTION

In order to test the magnets, the related cryogenics and the other components of the LHC under realistic operating conditions, CERN has ordered from industry a number of full-scale prototype superconducting magnets which will be installed and operated in a 110 m long string representing a full period of the LHC. The magnet string will allow verification of the performance and of the thermal and mechanical behaviour of a long cryogenic magnet system operating with superfluid helium at 1.9 K. This second generation facility is called the LHC Prototype Cell, hereafter called String 2. One electrical distribution feed box (DFB) is needed for powering the magnets in String 2, namely 2 short straight sections (containing each a quadrupole and corrector magnets), and 6 dipoles (also containing a number of corrector magnets).

The String 2 DFB is composed of a saturated liquid helium vessel at 4.6 K, 0.135 MPa, a thermal shield providing heat interception at 50 K, and a vacuum vessel. It has been designed at CERN and is manufactured in collaboration with the Budker Institute of Nuclear Physics (BINP) in Novosibirsk, Russian Federation. This complex cryostat houses six 13 kA and twenty-four 600 A prototype high temperature superconductor (HTS) current leads, ref. [1], which provide the electrical powering of

LHC main dipole and quadrupole magnets, together with their correctors.

Each 13 kA lead is flanged onto a single chimney, thermally and vacuum insulated and cryogenically actively cooled, linking the warm atmospheric top part to the saturated liquid helium bath containing the bottom part of the lead. Four 600 A leads are grouped together onto a common flange and in a common chimney (fig. 1).

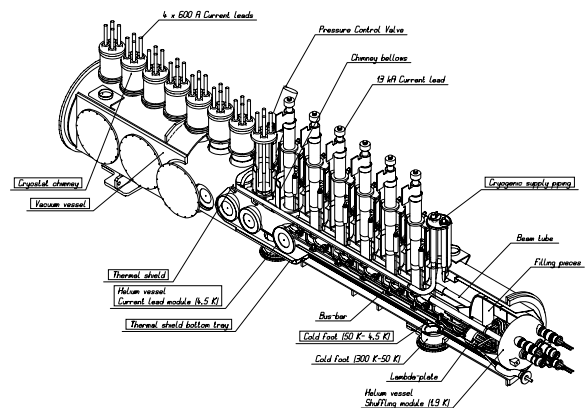

Figure 1: the String 2 DFB

2 DESIGN

2.1 Functions

The main functions of the DFB are:

- to provide an effective thermal transition between an electrical current source operating at room temperature (300 K) and cryomagnets operating at 1.9 K, with a minimum consumption of helium,
- to mechanically support the HTS current leads and be able to withstand safely the mechanical forces applied at the end of the String,
- to provide the cryogenic circuits necessary for safe and reliable operation of the current leads

2.2 Mechanical aspects

The DFB cryostat features essential characteristics of the LHC arc cryostat, such as transverse dimensions (which are given by the tunnel size while leaving passage for the magnet transport vehicles). The DFB is designed to permit in-situ replacement of any HTS lead without dismantling the whole cryostat. This feature will arguably be maintained in the LHC DFB's, to allow replacement of faulty leads in the tunnel. An additional

constraint on the String 2 DFB is the necessity of integrating current leads from different manufacturers, in their prototype configuration, implying some trade-offs between flexibility and optimisation.

The resulting geometry for the cryostat is a tube with many side openings and vertical passages (chimneys) for lead insertion, permitting easy electrical connection of each lead to its corresponding superconducting busbar.

The chimneys are equipped with bellows that enable assembly by insertion of the helium vessel – pre-assembled with its busbars and lambda-plate (§ 2.4) - into the vacuum vessel, while at the same time compensating for thermal contraction of the helium vessel during cool-down. This assembly technique (§ 4) mimics that of the LHC main magnets.

The design follows the French code for Pressure Vessels (CODAP). Due to its geometrical complexity, “design by rule” needed to be complemented by “design by analysis” (finite elements): for instance, figure 2 shows stress concentrations near the chimney and side opening nozzles in the helium vessel.

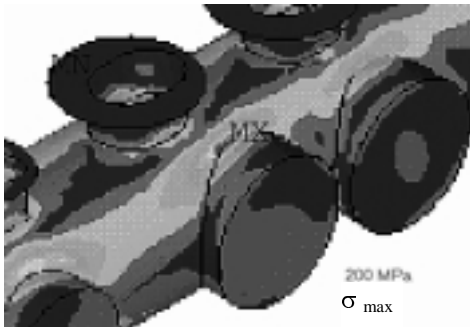

Figure 2: Helium vessel finite element results.

As a result of these analyses, the helium vessel is made of a 6 mm thick AISI 316 LN stainless steel shell in order to safely sustain the high stresses caused by the transient internal pressures resulting from resistive transitions.

An additional feature is the presence of the so-called “shuffling module”, a pressurised superfluid helium enclosure in direct communication with the magnet bath. Inside this enclosure, electrical busbars are spatially redistributed to meet the required LHC busbar layout, for standard interconnection to the magnet string, ref. [2].

2.3 Cryogenic scheme

The helium vessel housing the current leads is filled with saturated liquid helium at 4.6 K, 0.135 MPa.

The temperature of a current lead is controlled by throttling its individual valve acting on a flow of externally supplied 20 K gaseous helium. Helium gas from the vessel, produced by the current lead heat conduction and the ohmic resistance of the busbar splices, is used to cool the HTS part of the lead and exits the latter in the cryostat neck at a temperature of 50 K.

A flow control valve then limits this flow to the amount necessary to cool the cryostat necks so that this gas exits the cryostat at ambient temperature. The mass flow in excess is returned to the helium vessel, then into the 20 K line via a cold valve, prior to injection into the current lead, ref. [2].

2.4 Lambda-plates

The transition from the saturated liquid helium bath of the DFB to the pressurised superfluid helium bath of the magnets is made through a so-called lambda-plate, which is a plug crossed by the superconducting 13 kA busbars and 600 A cables. The main functions of the lambda-plate are thermal and hydraulic: it should restrict to a minimum the heat transfer to superfluid helium, and hydraulically separate the 2 MPa design pressure magnet cold masses from the 0.25 MPa design pressure helium vessel of the DFB. It must therefore be leaktight, ref. [3]. The current concept includes a bulk glass fiber reinforced polymer material which is glued around the busbars in a “sandwich” manner, the whole assembly being inserted into a tube where leaktightness is ensured by a metallic joint. For LHC DFB’s, this concept will a priori be retained but other techniques are still under evaluation, including ceramic lambda-plates.

Current prototypes for the lambda-plate have been tested in liquid nitrogen with leak rates measured better than 10^{-7} mbar.l/s. Work is in progress to correlate these values to ambient temperature leak rate specifications, ref. [3].



Figure 3: the prototype lambda-plate

3 MANUFACTURING

The DFB main cryostat mechanical parts are manufactured by BINP. These include the 316 LN stainless steel helium vessel, 304 L vacuum vessel, aluminium thermal shield, and ancillaries (chimneys ...).

BINP established all manufacturing drawings, welding procedures, and performs leaktightness and pressure tests.

BINP also participates in the assembly of the cryostat at CERN.



Figure 4: The Helium Vessel at BINP as of June 15, 2000

4 INTEGRATION

Following reception of equipment at CERN, considerable assembly work still needs to be performed, see figure 5. The main steps in assembly are:

- realisation of the superconducting busbar bundle (32 x 600 A and 6 x 13 kA busbars are grouped together), including the lambda-plate
- insertion of the busbar bundle into the helium vessel
- closing the vessel by welding the shuffling module
- assembling the 50 K thermal shield
- insertion of the resulting "cold mass" into the vacuum vessel
- insertion of the current leads and electrical connection to the busbars
- closing the cryostat and integration into String 2.

Intermediate tests for electrical, mechanical, leak-tightness performance are of course foreseen.

5 LHC DFB'S

Since the LHC is composed of eight arcs electrically powered at both their extremities, there will be 16 arc DFB's in the LHC, named DFBA. These will not have the same length because the latter is given by the number of supported current leads, which is itself determined by the number of electrical circuits of the machine. The number of leads is however generally much larger for DFBA than for the String 2 DFB, resulting in additional complexity for the cryostats and the lambda-plates. Typically the maximum length of the cryostats will vary between 6 and 15 m, all current leads being arranged in a single line.

Profiting from String 2 DFB experience, an iterative design process is currently on-going between the current leads and cryostat, taking into account all interface

constraints in the LHC tunnel, into which the first DFBA will be integrated in February 2003.

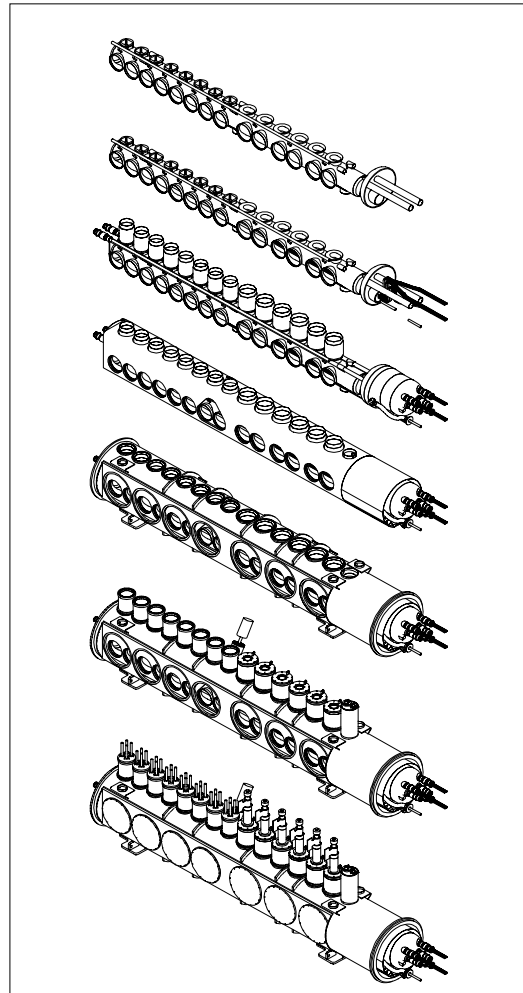

Figure 5: Assembly sequence

6 CONCLUSION

The electrical distribution feed box for the LHC prototype cell is a complex cryostat designed at CERN and manufactured in collaboration with BINP. The 16 large arc DFB's for the LHC machine are still more challenging units; they are currently in the design stage.

REFERENCES

- [1] A. Ballarino, "Application of HTS to Accelerators", these proceedings.
- [2] P. Sacré, P. Trille "String 2 DFB Design File", LHC-CRI Technical Note, June 2000
- [3] P. Sacré, "Functional specification for lambda-plates", in preparation

ACKNOWLEDGEMENTS

The help of L. Serio and R. Moiroux is gratefully acknowledged.