



LARGE CRYOGENICS SYSTEMS AT 1.8 K

L. Tavian

Abstract

Cryogenics is now widely present in large accelerator projects using applied superconductivity. Economical considerations permanently require an increase of the performance of superconducting devices. One way to do this consists to lower their operating temperature and to cool them with superfluid helium. For this purpose, large cryogenic systems at 1.8 K producing refrigeration capacity in the kW range have to be developed and implemented. These cryogenic systems require large pumping capacity at very low pressure based on integral cold compression or mixed cold-warm compression. This paper describes and compares the different cooling methods with saturated or pressurised superfluid helium, gives the present status of the available process machinery with their practical performance, and reviews the different thermodynamical cycles for producing refrigeration below 2 K, with emphasis on their operational compliance.

Invited Paper at the Seventh European Particle Accelerator Conference (EPAC 2000)
26-30 June 2000, Vienna, Austria

Administrative Secretariat
LHC Division
CERN
CH - 1211 Geneva 23
Switzerland

Geneva, 23 September 2000

LARGE CRYOGENIC SYSTEMS AT 1.8 K

L. Tavian, CERN, Geneva, Switzerland

Abstract

Cryogenics is now widely present in large accelerator projects using applied superconductivity. Economical considerations permanently require an increase of the performance of superconducting devices. One way to do this consists to lower their operating temperature and to cool them with superfluid helium. For this purpose, large cryogenic systems at 1.8 K producing refrigeration capacity in the kW range have to be developed and implemented. These cryogenic systems require large pumping capacity at very low pressure based on integral cold compression or mixed cold-warm compression. This paper describes and compares the different cooling methods with saturated or pressurised superfluid helium, gives the present status of the available process machinery with their practical performance, and reviews the different thermodynamical cycles for producing refrigeration below 2 K, with emphasis on their operational compliance.

superfluid cooling is the dependence of the critical current density of superconducting material of technical interest like industrial NbTi superconducting alloys. Accelerators based on this technology have to operate at 1.9 K minimising the amount of superconductor and hence the capital costs (see Figure 2).

1 INTRODUCTION

In the 1980's, Tore Supra (TS) [1] was the first large physics instrument using a cryogenic system at 1.8 K and has proven the technical feasibility of such systems. CEBAF [2] was the first accelerator project using this technology for cooling superconducting RF cavities. The LHC project [3,4] makes use of large cryogenic capacity at 1.8 K for cooling superconducting high-field magnets. Future accelerator projects like TESLA [5] are also based on superfluid technology. Table 1 gives the main characteristics of superfluid cryogenic systems. Some existing 4.5 K projects like the LHD [6] have already designed their cooling schemes for an eventual 1.8 K upgrade.

Table 1: Main superfluid cryogenic systems

	TS	CEBAF	LHC	TESLA
Temperature [K]	1.8	2	1.9	2
Nb of units [-]	1	1	8	7
Capacity/unit [W]	300	4800	2400	3800
Length/sector [m]	N/A	500	3300	2670

The cost optimisation of accelerators depends on their operating temperature. In the case of high frequency superconducting devices, such as acceleration cavities, the main drive for superfluid cooling is the exponential dependence of the BCS losses on the ratio of operating-to-critical temperature. Accelerators based on this technology have to operate around 2 K minimising the capital costs and overall energy consumption (see Figure 1). In the case of high-field superconducting devices, such as cryomagnets, the main drive for

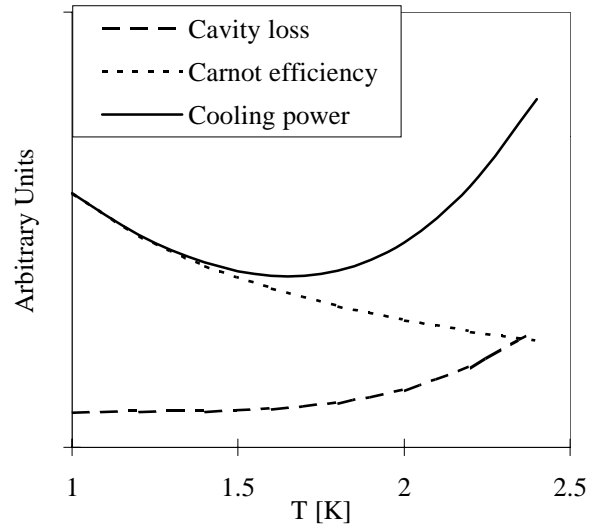

Figure 1: Optimal operating temperature for superconducting RF cavities

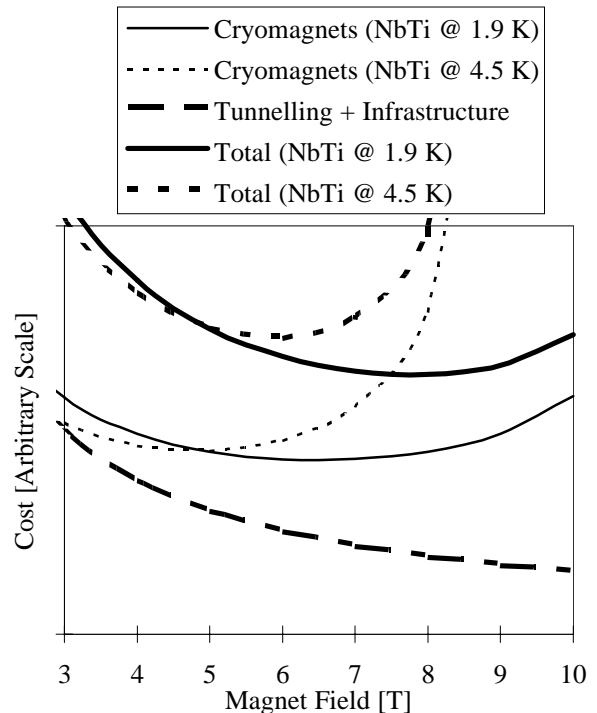

Figure 2: Cost optimisation for hadron colliders at a given energy

2 COOLING METHODS AT 1.8 K

The superconducting devices operating in superfluid helium can be cooled with saturated or pressurised superfluid helium [7]. Figure 3 shows the different cooling schemes.

Devices cooled with superfluid saturated helium have to operate at a pressure below 3 kPa. At this pressure, the gaseous helium phase has a poor dielectric strength. Consequently, to avoid electrical breakdown, this cooling method has to be applied only for devices which can operate in any circumstances with a voltage difference of about 100 V. Moreover, working in sub-atmospheric conditions increases the risk of air inleaks through the different electrical and instrument feedthroughs which are unavoidable in superconducting apparatus.

Devices cooled with pressurised superfluid helium are prevented from air inleaks and can be operated with voltage differences in the kV range. Liquid-liquid heat exchangers [8] are required, introducing an additional temperature difference for the heat extraction. However, the volume of saturated liquid in these heat exchangers can be small in comparison with the liquid needed at the device side. This limited volume of saturated liquid decreases the time needed for the pump-down. Pressurised superfluid helium has also more enthalpy margins for buffering transient energy deposition.

Table 2 resumes the advantages (+) and drawbacks (-) of both cooling methods. In conclusion, saturated superfluid helium cooling seems more adapted to RF cavities whereas pressurised superfluid helium cooling better suits superconducting magnets.

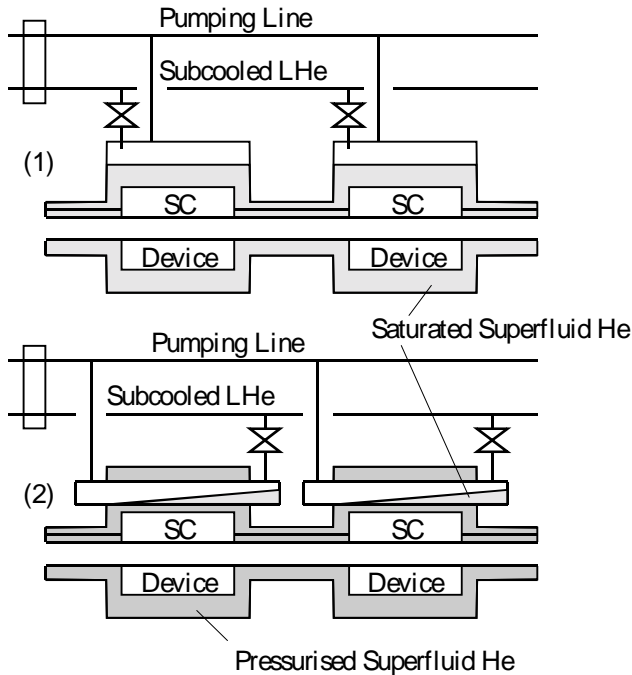

Figure 3: Cooling methods with saturated (1) and pressurised (2) superfluid helium

Table 2: Cooling method comparison

	Sat. He	Pres. He
Air inleak prevention	-	+
ΔT budget	+	-
Dielectric strength	-	+
Pump-down time	-	+
Enthalpy margin for transient	-	+
Technical simplicity	+	-

3 AVAILABLE PROCESS COMPONENTS

Large cryogenic capacity below 2 K requires to compress the pumping flow from a few kPa up to atmospheric pressure by using a multistage compressor set. Producing the whole compression at room temperature is not compatible with the pumping speed of warm machines. Consequently, the very-low-pressure gaseous helium has to be pumped at low temperature when it is dense and cold compressors are required at least for the first stages. The high compression stage may be performed by warm sub-atmospheric compressors. To increase the efficiency of the final Joule-Thomson expansion producing the saturated superfluid helium, incoming liquid helium is subcooled down to 2.2 K in counter-flow heat exchangers. With respect to conventional 4.5 K cryogenic systems, large superfluid cryogenic systems require cold compressors, possibly warm sub-atmospheric compressors and low-pressure subcooling heat exchangers.

3.1 Cold Compressors

In 1993, CERN has started a R&D programme [9] on cold compressors, procuring from European and Japanese companies, three hydrodynamic compressors with the aim to investigate critical issues such as drive and bearing technology, impeller and diffuser hydrodynamics, mechanical and thermal design, as well as their impact on overall efficiency [10]. Following this programme, contracts have been adjudicated to Air Liquide (France) [11] and a consortium of IHI (Japan) and Linde Kryotechnik (Switzerland) [12] for the delivery and installation of four 1.8 K refrigeration units for the LHC [13]. The unit suppliers have chosen electrical motor drives (3-phase induction motors) with active magnetic bearings working at room temperature, axial-centrifugal (three-dimensional) impellers and fixed-vane diffusers.

Figure 4 show a typical operating field of these hydrodynamic compressors, which displays the pressure ratio as a function of the reduced flow m^* and the reduced speed N^* defined as follows:

$$m^* = \frac{m}{m_0} \cdot \sqrt{\frac{T_{in}}{T_{in_0}}} \cdot \frac{P_{in_0}}{P_{in}} \quad \text{and} \quad N^* = \frac{N}{N_0} \cdot \sqrt{\frac{T_{in_0}}{T_{in}}}$$

with m the mass-flow, N the rotational speed, T_{in} and P_{in} the inlet temperature and pressure of the cold compressor and with the subscript 0 corresponding to the design conditions.

The working area is limited on the left side by the stall line, on the right by the choke line and on the top by the maximum rotational speed of the drive. At constant pressure ratio, such hydrodynamic machines have a operating range of 20 to 25 % before reaching the stall line. Concerning hydrodynamic design, the cold compressor manufacturers have made significant improvements. Figure 5 shows the isentropic efficiency evolution of cold compressors. The isentropic efficiency of recent cold compressors can be expected up to 75 % at their design point. Figure 6 shows the evolution of pressure ratio and rotational speed with respect to the stage number for the LHC cold compressors. The maximum achievable pressure ratio for the lowest stages, is limited by the impeller design. For the higher stages, the maximum pressure ratio is limited by other considerations such as the maximum drive power and the maximum rotational speed.

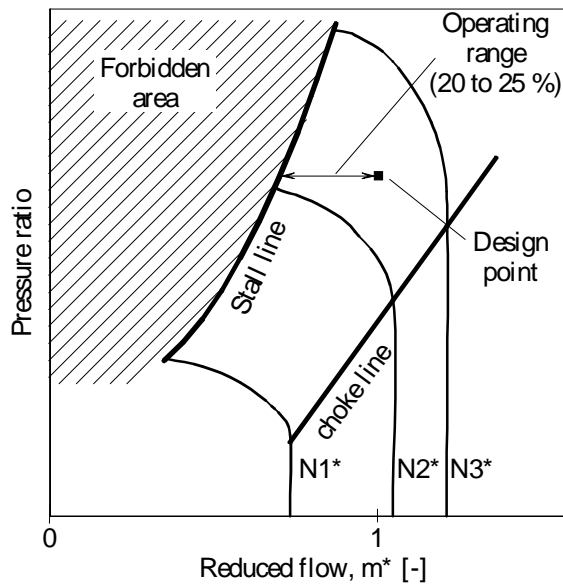

Figure 4: Typical pressure field of hydrodynamic compressors

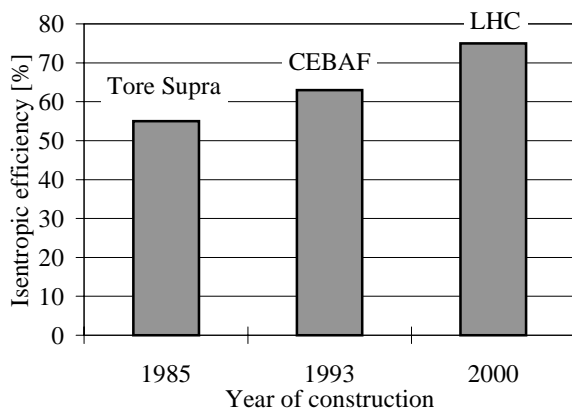

Figure 5: Evolution of isentropic efficiency of cold compressors

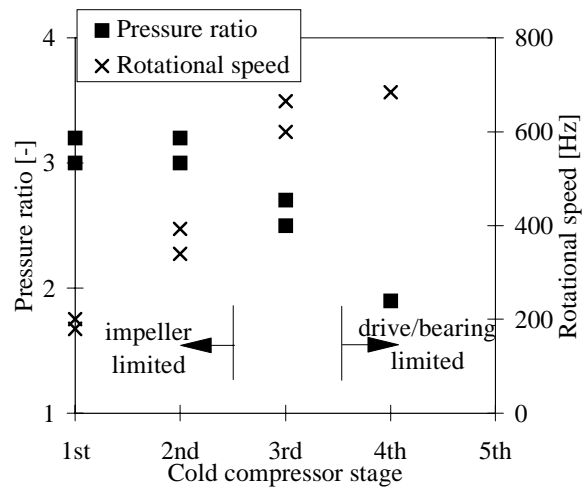

Figure 6: Pressure ratio and rotational speed of LHC cold compressor stages

3.2 Warm sub-atmospheric Compressors

For large superfluid cryogenic systems, oil liquid ring pumps (LRP) or lubricated screw compressors (LSC) can be used in series with cold compressors. These sub-atmospheric compressors are positive displacement machines having volumetric characteristics. Screw compressors have been chosen for the LHC. This type of compressor is currently used in helium refrigeration and their implementation in a 1.8 K cycle provides a uniform approach. Special attention has to be paid to the protection against air inleaks: in particular the motor shaft has to be placed on the discharge side to work above atmospheric pressure. Table 3 gives the main characteristics of warm sub-atmospheric compressors used or foreseen in large superfluid cryogenic systems. For the LHC, the machine characteristics of the two suppliers (S1 and S2) are given. The biggest available machines have a swept volume of about 6000 m³/h. The isothermal efficiency decreases with the inlet working pressure as shown in Figure 7.

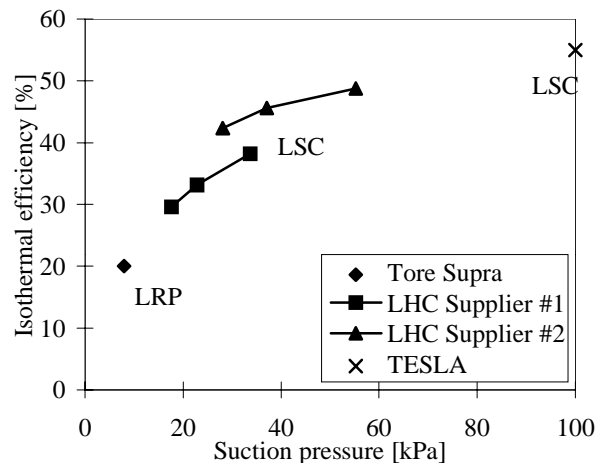

Figure 7: Isothermal efficiency of warm sub-atmospheric compressors

Table 3: Sub-atmospheric compressor characteristics

Type [-]	TS	LHC		TESLA*
	LRP	S1	S2	LSC
Nb of stages [-]	1	2 in //	1	1
Inlet Pressure [kPa]	8	33	60	100
Swept Vol. [m ³ /h]	4200	4570	5920	< 4537

*: Pre-design cycle

3.3 Subcooling Heat Exchangers

This counter-flow heat exchanger has to subcool liquid helium from 4.5 K down to 2.2 K by enthalpy exchange with the very-low-pressure saturated vapour. To be efficient, this heat exchanger has to produce limited pressure drop in the very low-pressure stream. Typically, a maximum pressure drop of 100 Pa is acceptable, corresponding to a few per cent of the absolute saturation pressure. For the LHC, CERN has procured from industry prototype subcooling heat exchangers of different designs, presently under evaluation at CEA, Grenoble (France). For reason of feasibility and qualification procedure, relatively small-size heat exchangers designed for a capacity of 5 to 20 g/s have been distributed all around the LHC machine. The design of full-flow heat exchangers (up to 200 g/s) is not straightforward and special attention has to be paid to the qualification and performance of such components.

4 THERMODYNAMIC CYCLES

Two types of cycles are generally considered to produce refrigeration below 2 K (see generic scheme in Figure 8):

- The “integral-cold” compression cycle based on multistage cold compressors.
- The “mixed” compression cycle based on a combination of cold compressors in series with warm sub-atmospheric compressors.

In high-energy accelerators, the dynamic heat loads correspond to a large part of the total load. Between standby operating mode without beams and full-load operating mode, large dynamic ranges (factor 3 for LHC and up to 5 for TESLA) are required for the superfluid cryogenic system.

4.1 Integral Cold Compression Cycles

Depending on the operating temperature (2 K or 1.8 K), the “integral cold” compression cycle requires at least 4 to 5 stages in series in order to perform the overall pressure ratio of 45 to 80. The compressed helium is directly re-injected in the cold low-pressure (LP) stream of the 4.5 K refrigerator.

The main drawback of this cycle concerns the turndown capability. The cold compressor set has to guarantee the same pressure ratio for any load. Due to the limited operating range of hydrodynamic machines working at constant pressure ratio (see Figure 4), only a

reduction of 20 % of the flow rate is possible, i.e. a dynamic range limited to a factor 1.25. Below this limit, additional electrical heating has to be introduced to compensate for the load reduction. Such a cycle is therefore not very compliant with respect to turndown capability. Consequently, its operating cost is not optimised for low-load operation [14].

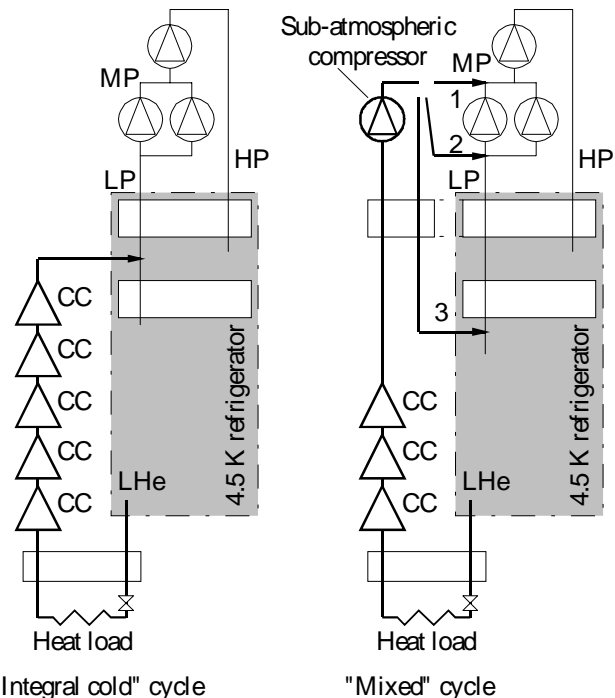

Figure 8: Generic scheme of superfluid cryogenic cycles

4.2 “Mixed” Compression Cycles

In the “mixed” compression cycle, depending on the swept volume and number of warm sub-atmospheric compressors, the number of cold compressor stages can be reduced to 3. The compressed helium can be re-injected in the 4.5 K refrigerator at different levels:

- at the warm medium-pressure (MP) side (connection #1 on Figure 8). This requires the use of screw compressors having a sufficient built-in pressure ratio as warm sub-atmospheric compressors. In this case, the enthalpy of the cold gas at the outlet of the cold compressors has to be recovered by the heat exchangers of the 4.5 K refrigerator. The main advantage of this solution is that, the same oil-removal and final-cleaning systems can be used for the warm sub-atmospheric compressors and for the booster stages of the 4.5 K refrigerators, minimising the investment cost of the system.
- at the warm low-pressure (LP) side (connection #2 on Figure 8). This solution is compatible with the use of either screw compressors or liquid ring pumps. The enthalpy of the cold gas at the outlet of the cold compressors also has to be recovered by the heat exchangers of the 4.5 K refrigerator. In this case, the

warm sub-atmospheric stage requires its own oil removal system.

- at the cold low-pressure side (connection #3 on Figure 8). This is required when the enthalpy of the cold gas at the outlet of the cold compressors cannot be recovered by the heat exchangers of the 4.5 K refrigerators (LHC case) [15]. In this case, the warm sub-atmospheric compressor stage requires its own oil removal system and final cleaning system (coalescers and charcoal adsorbers), increasing the investment cost of the system.

The main advantage of the “mixed” cycle resides in its turndown capability. With sub-atmospheric compressors, with volumetric characteristics, the pressure at the outlet of the cold compressors decreases linearly with respect to the flow-rate to be compressed, i.e. if the temperature and the rotational speed do not change, the reduced flow-rate m^* stays constant keeping the working point fixed in the operating field. Such a cycle can handle a large dynamic range without any additional electrical heating. In addition, the total pressure ratio which has to be performed by the cold compressors, is reduced and the speed of some machines can be lowered, thus decreasing the total compression power and saving operating cost.

Another advantage concerns the possibility of keeping the superconducting device in cold standby mode with the cold compressors freewheeling and only running the warm sub-atmospheric compressor. This mode allows repairing or exchanging a cold-compressor cartridge without partial helium emptying of the system. In addition, the warm sub-atmospheric compressors are very useful during transient operation modes like cool-down and pump-down, in which the cold compressors are far from their design conditions and difficult to tune.

The only drawback of this cycle concerns the risk of air inleaks due to the presence of sub-atmospheric circuits in air. Helium guards are recommended to prevent helium pollution.

The “mixed” compression cycle is more compliant than the “integral cold” compression cycle and is recommended for superfluid cryogenic systems having a large dynamic range.

5 CONCLUSION

Superfluid cryogenic systems are now present and foreseen in large projects using applied superconductivity. Two cooling methods can be envisaged. The cooling with saturated superfluid helium is more adapted to superconducting radio-frequency cavities whereas the cooling with pressurised superfluid helium better suits superconducting high-field magnets. Cold compressors, warm sub-atmospheric compressors and low-pressure subcooling heat exchangers required for such systems are now available from industry. The isentropic efficiencies of cold compressors have improved and now reach 75 %. The “mixed” compression cycles based on cold compressors in series with warm sub-atmospheric compressors of volumetric type are more

compliant and better suited to large superfluid cryogenic systems requiring efficient turndown capability.

REFERENCES

- [1] G. Claudet *et al.*, “Tore Supra and HeII cooling of large high-field magnet”, *Adv. Cryo. Eng.* 35A (1990) 55-67
- [2] C.H. Rode, “CEBAF cryogenic system”, paper presented at PAC’95, Dallas (1995)
- [3] L. Evans, “The Large Hadron Collider: present status and prospects”, invited paper presented at MT16, Ponte Vedra Beach, USA (1999)
- [4] Ph. Lebrun, “Cryogenic for the Large Hadron Collider”, invited paper presented at MT16, Ponte Vedra Beach, USA (1999)
- [5] G. Horlitz *et al.*, “A 2 Kelvin helium II distributed cryogenic system for the 2x250 GeV e^+e^- linear collider, Cryogenics 34 ICEC Supplement (1994) 131-134
- [6] T. Mito *et al.*, “Development of a cryogenic system for the Large Helicoidal Device”, *Adv. Cryo. Eng.* 43A (1998) 589-596
- [7] Ph. Lebrun, “Superfluid helium as a technical coolant”, *Atti XV Congresso Nazionale sulla Trasmissione del Calore, Edizioni ETS, Politecnico di Torino, Italy (1997) 61-77*
- [8] Ph. Lebrun *et al.*, “Cooling string of superconducting devices below 2 K: the helium II bayonet heat exchanger”, *Adv. Cryo. Eng.* 43A (1998) 419-426
- [9] Ph. Lebrun *et al.*, “Development of large-capacity refrigeration at 1.8 K for the Large Hadron Collider”, *Proc. Kryogenika’96, Icaris, Praha, Czech Republic (1996) 54-59*
- [10] A. Bézaguet *et al.*, “Performance assessment of industrial prototype cryogenic helium compressors for the Large Hadron Collider”, *Proc. ICEC17, IoP, Bristol, UK (1998) 148-148*
- [11] B. Hilbert *et al.*, “2.4 kW at 1.8 K refrigeration units for CERN LHC project supplied by Air Liquide”, paper presented at ICEC18, Mumbai India (2000)
- [12] H. Asakura *et al.*, “Four 2400 W / 1.8 K refrigeration units for CERN-LHC: the IHI/Linde system”, paper presented at ICEC18, Mumbai India (2000)
- [13] S. Claudet *et al.*, “Specification of eight 2400 W @ 1.8 K refrigeration units for the LHC”, paper presented at ICEC18, Mumbai India (2000)
- [14] S. Claudet *et al.*, “Towards cost-to-performance optimisation of large superfluid helium refrigeration systems”, paper presented at ICEC18, Mumbai India (2000)
- [15] F. Millet *et al.*, “A possible 1.8 K refrigeration cycle for the Large Hadron Collider”, *Adv. Cryo. Eng.* 43A (1998) 387-393