

## PRESSURE MEASUREMENT – TOTAL PRESSURES

*Chr. Edelmann*

Otto von Guericke University, Magdeburg, Germany

### Abstract

Gauges for the measurement of total pressures in the vacuum range using different physical effects are described (with the exception of ionization gauges that are discussed in a separate chapter). Advantages, disadvantages, tendencies in development, sources of error, and pressure ranges for different applications are discussed.

### 1. INTRODUCTION

The term ‘vacuum’ designates a pressure range which extends from pressures somewhat lower than atmospheric pressure down to pressures lower than  $10^{-14}$  mbar. Thus it spans a pressure range with more than 17 orders of magnitude that can be arbitrarily subdivided into ranges of about three to five decades of pressure. According to DIN 28 400-1 (in agreement with ISO 3529-1) the overall pressure range is divided into four ranges. Since the beginning of the nineties pressures lower than  $10^{-12}$  mbar have been defined as extreme high vacuum. In Table 1 this fifth range is in brackets since it is still not a standardized definition.

Table 1  
Pressure ranges

Definition	Abbreviation	Pressure range
Rough vacuum		1 mbar $\leq p <$ atm. pressure
Medium vacuum		$10^{-3}$ mbar $\leq p <$ 1 mbar
High vacuum	hv	$10^{-7}$ mbar $\leq p <$ $10^{-3}$ mbar
Ultra high vacuum	uhv	$(10^{-12}$ mbar) $\leq p <$ $10^{-7}$ mbar
(Extreme high vacuum)	(xhv)	( $p <$ $10^{-12}$ mbar)

Assuming ideal thermodynamic equilibrium we can define the pressure  $p$  by Eq. (1):

$$p = \frac{F}{A} \quad (1)$$

( $F$  force acting perpendicularly onto an area  $A$ ). According to the international system of units the pressure unit is:

$$1[p] = 1 [F] / 1 [A] = 1 \text{ N/m}^2 = 1 \text{ Pa} = 0.01 \text{ mbar.}$$

As the ambient atmospheric air and the residual gas in a vacuum chamber both consist of  $i$  different gas components each of them has a partial pressure  $p_{part/i}$ . The partial pressures of all gas components add linearly to give a total pressure  $p_{total}$  according to Dalton’s law:

$$p_{total} = \sum_i p_{part/i} \quad (2)$$

In future I consider only the total pressure  $p_{total}$  which I abbreviate by  $p$ . The following different physical effects, depending on the gas pressure, can be used for the measurement of total pressures:

- force effect
- heat transport by heat conductivity of the gas
- heat transport by convection of the gas
- viscosity of the gas
- radiometer effect
- scattering of electrons by collisions with gas particles
- excitation of gas particles by electron impact
- ionization of gas particles by electron impact
- deceleration of ions in an electric field by collisions with gas particles.

Gauges using these different effects for the determination of pressures will now be described.

## 2. GAUGES USING FORCE EFFECTS FOR PRESSURE MEASUREMENT

### 2.1 Piston gauges

Because of their complicated structure and operation these gauges are only used for calibration purposes. According to Eq. (1) the force  $F$  acting on the area  $A$  of a moveable piston placed in a cylinder can be used for the determination of the pressure. Figure 1 represents the principle. A piston  $P$  with a mass  $m$  and a cross section of area  $A$  limits a well defined gas volume  $V$ . If the pressure in  $V$  is increased with the help of a gas inlet the volume can be restored by an additional weight of mass  $\Delta m$ . For equilibrium we find :

$$p = \frac{(m + \Delta m)g}{A} \quad (3)$$

where  $g$  is the gravitational acceleration.

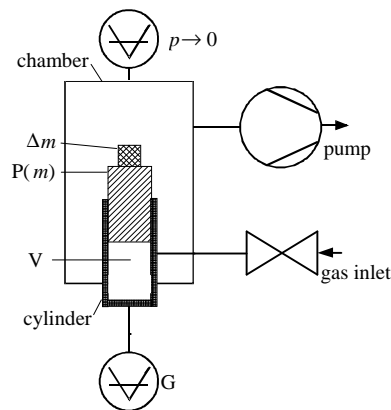

**Fig. 1** Principle of a Piston gauge

To avoid the influence of the surrounding atmosphere the cylinder and piston are placed in an additional chamber, which is evacuated. To reduce the influence of friction between the cylinder and piston the piston is made to rotate. With the help of such an apparatus as that represented in Fig. 1 it is possible to calibrate any gauge indicated in the sketch by  $G$ .

### 2.2 Bourdon gauge

The Bourdon gauge (see Fig. 2a) consists of a bent tube with an elliptic cross section closed at one end and connected at the other open end to the chamber in which the pressure is to be measured. Pressure

differences between the environment of the gauge and the interior cause forces to act on the two walls of the tube (Fig. 2b) so that it is bent by an amount that depends on the pressure difference between the environment and the interior. The bending is transformed by a lever to a pointer whose position can be calibrated. The importance of this type of gauge is that it is very robust and that it covers a range of pressure measurement from pressures higher than atmospheric pressure down to rough vacuum (about 10 mbar). The accuracy and reproducibility are relatively poor, so that it is not suitable for precision measurements, and its usefulness for vacuum measurements is limited.

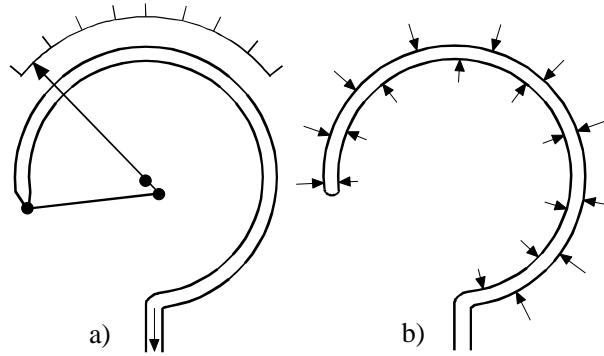

Fig. 2 Bourdon gauge, a) principle, b) distribution of forces

### 2.3 Diaphragm gauges

If a diaphragm or a bellows separates two regions with different pressures ( $p_1, p_2$ ) the difference  $\Delta p$  ( $\Delta p = p_1 - p_2$ ) of these two pressures causes a force that deforms the diaphragm or bellows. There are many possibilities for measuring this deformation, e.g. mechanically by a lever and a pointer, optically by a mirror and a light pointer, or electrically by changes of the capacity of a capacitor formed by the diaphragm and an additional electrode which is usually placed in a region of very low pressure (see Figs. 3a ... 3c). For precision measurements one side of the diaphragm is evacuated to very low pressure. This is called a reference vacuum. The other side is exposed to the pressure to be measured. The deformation of the diaphragm depends on, but is not proportional to, the pressure difference [1]. These days linearization of the pressure vs. deformation reading is mostly performed by electronic circuits. Thus it is possible to make pressure measurements in a range between some hundred mbar and  $10^{-4}$  mbar with such a precision that this type of gauge can be used as a secondary standard gauge. The lower pressure limit is caused by the thermal dilatation that has the same order of magnitude as the deformation at very low pressures. Some special alloys like stainless steel or special ceramics such as  $\text{Al}_2\text{O}_3$  with high density, are used as materials for the diaphragms. Generally the low pressure in the region of the reference vacuum is maintained by the use of getters. Frequently the electrodes and the circuits for the pressure reading are placed in the region of the reference vacuum. Figure 4 shows a diaphragm gauge with electrical reading. The pressure reading is independent of the gas composition. A pressure range from atmospheric pressure to  $10^{-4}$  mbar is covered. The high reliability, simple handling, electrical read-out that can easily be recorded, and the robust construction are reasons to use it for many practical applications.

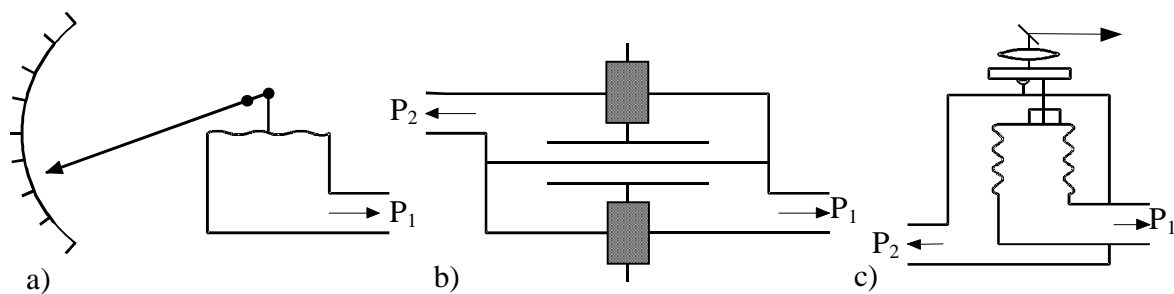
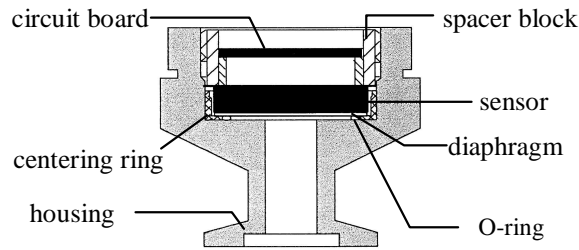

Fig. 3 Diaphragm gauges with a) a mechanical, b) an electrical and c) an optical display



**Fig. 4** Diaphragm gauge with electrical reading

## 2.4 Piezoresistive diaphragm gauge

Similar to the diaphragm gauge the piezoresistive gauge consists of a small evacuated capsule closed with a thin silicon diaphragm at the side exposed to the space whose pressure is to be measured. On one side of this diaphragm are placed thin film piezoresists produced by evaporation and which are connected to form a bridge circuit. By deformation of the silicon diaphragm the bridge is put out of balance by an amount depending on the deformation. To avoid destruction of the silicon diaphragm by corrosive gases there exist models in which a small volume filled with special oil is placed between the silicon diaphragm and the vacuum space. This volume is closed at the side of the vacuum space whose pressure is to be measured by a thin stainless-steel diaphragm. The special oil serves as an incompressible pressure transducer.

Depending on the gauge construction the pressure reading covers a range of 0.1 to 200 mbar or 1 to 2000 mbar [2]. The pressure reading is independent of the kind of gas.

## 3. GAUGES USING THE HYDROSTATIC PRESSURE OF MERCURY OR OTHER NON-VOLATILE LIQUIDS

### 3.1 U-tube gauge

These gauges use the hydrostatic pressure of a liquid column for pressure reading. Mostly mercury is used as the liquid because of its low vapor pressure and its cohesion characteristics.

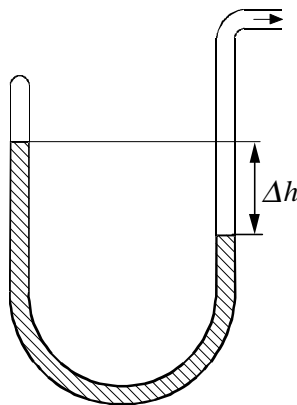

**Fig. 5** U-tube gauge with one closed glass tube

In the simplest case a gauge of this type consists of a U-shaped glass tube closed at the one end and connected at the other to the chamber whose pressure is to be measured (Fig. 5). The tube is filled with mercury so that in the volume between the closed end and the level of the mercury column there is only the vapor pressure of the mercury and is called Torricelli's vacuum. The difference in heights of the mercury levels in the two legs of the U-shaped tube is proportional to the pressure

$$p = \rho g \Delta h \quad (4)$$

where  $\rho$  is the density of the used liquid, usually mercury,  $g$  gravitational acceleration, and  $\Delta h$  the difference in heights of the levels of the two columns. Because the lowest measurable difference of heights of the mercury levels is about 1 mm the lowest pressure detectable with this gauge is in the order of 100 Pa (1 mbar). Because of its uncertainty, its limited range of pressure reading, and the absence of possibilities for electronic recording, this simple type of gauge has nearly no importance for practical application today.

### 3.2 Compression gauge

In contrast to the simple U-shaped gauge, more important is the compression manometer developed by Herbert McLeod in 1874 [3]. This so called McLeod gauge shown in Figs. 6a and 6b uses mercury as a liquid piston with which the gas of a well-defined volume  $V$  is compressed into a known small volume  $V_M$ . By this compression the pressure in the closed volume  $V_M$  is increased from the unknown low pressure  $p$  to the measurable higher pressure  $p + \rho g \Delta h$  according to Boyle's Law :

$$pV = \text{const.} \quad (5)$$

If the pressure  $p$  can be neglected in respect to the hydrostatic pressure  $\rho g \Delta h$ ,  $p$  can be calculated by the formula:

$$p = \rho g \Delta h \frac{V_M}{V}. \quad (6)$$

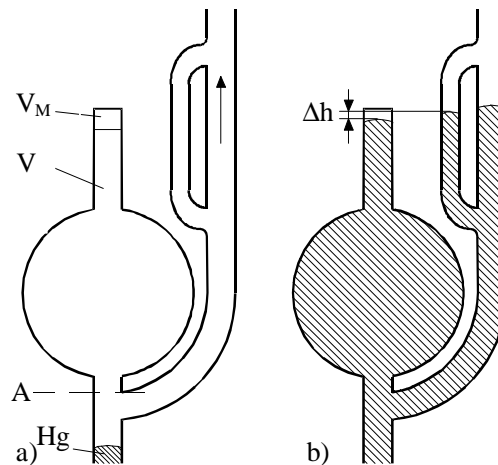

Fig. 6 McLeod gauge

To read the pressure it is necessary to determine the ratio of the volumes  $V$  and  $V_M$  and the difference  $\Delta h$  of the heights of the mercury levels. To avoid errors caused by different capillary depression both the capillary containing the little volume  $V_M$  (in the capillary) and the comparison capillary parallel to the connection tube are made from the same piece of glass capillary. The ratio of the two volumes can be determined exactly before the first use of the gauge and represents a special constant for this gauge. Thus, the McLeod gauge substitutes the measurement of a pressure by the measurement of only one length. Therefore it was used for a long time as a primary standard for pressure measurement. To measure the pressure one has to lower the columns of mercury so that the volume  $V$  is connected with the chamber in which the pressure is to be measured. After reaching the pressure equilibrium one has to compress isothermally the gas in the volume  $V$  up to the volume  $V_M$  and to determine the pressure in this volume. For this purpose one has to compare the heights of the mercury columns in the volume  $V_M$  and in the comparison capillary. After the measurement one has to lower the mercury level so that the volume  $V$  is connected again with the chamber in which the pressure is to be measured. Thus, the measurement is discontinuous and needs some dexterity. For precision measurements one has to stabilise the temperature in the surroundings of the gauge. The range of pressure measurement depends on the dimensions of the McLeod gauge. The lowest measurable pressures are about  $(1-0.5) 10^{-6}$  mbar. But for this purpose the volume  $V$  has to be at least  $1000 \text{ cm}^3$  and the volume  $V_M$  about  $1 \text{ mm}^3$  or smaller. In

such a gauge one has to handle a lot of mercury and any accident has terrible consequences for the laboratory where the gauge is used. Although the law of Boyle and consequently the pressure reading too do not depend on the gas composition the McLeod gauge is not able to read correctly pressures of condensable vapors because of their condensation during the compression process. Therefore the McLeod gauge is not convenient for industrial use.

#### 4. MODULATION GAUGE

Differentiating Eq. (4) one finds:

$$\Delta p = -p \frac{\Delta V}{V}. \quad (7)$$

This equation explains why periodical changes in  $V$  result in periodical changes of  $p$  so that  $\Delta p$  is proportional to  $p$ . The proportionality between these two quantities is used in the modulation gauge of Jurgeit and Hartung [4] shown in Fig. 7. In this gauge a small volume  $V$  is periodically changed with the help of a piezoelectric oscillator (2). The resulting periodical changes in pressure can be detected with the help of a sensitive capacitor microphone (1) whose signal is proportional to the changes of the oscillating pressure. This device is able to read pressures from atmospheric pressure down to  $10^{-6}$  mbar. The reading is only slightly influenced by the gas composition as a consequence of the conductance (3) between the oscillating volume of the gauge and the chamber in which the pressure is to be measured.

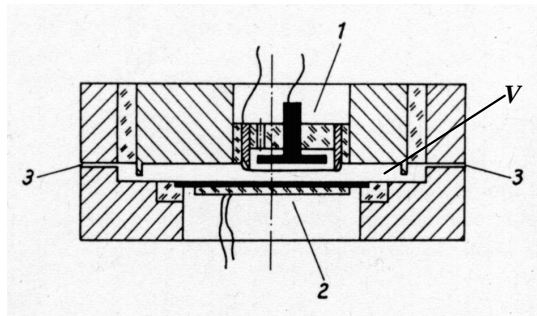

Fig. 7 Principle of the the modulation gauge of Jurgeit and Hartung

#### 5. GAUGES USING THE VISCOSITY OF A GAS FOR PRESSURE MEASUREMENT

##### 5.1 The physical basis

According to the kinetic theory of gases the viscosity  $\eta$  is described by Eq. (8) under the assumption that the equilibrium of the ideal gas is not disturbed:

$$\eta = \frac{1}{3} \rho \Lambda \bar{v} \quad (8)$$

with  $\rho$  the density of the gas,  $\Lambda$  the mean free path of a gas particle, and  $\bar{v}$  the average value of the velocity of a gas particle. If the mean free path is comparable to the dimensions of the system the viscosity decreases with lowering of the density (or pressure) of the gas. Thus, the viscosity of a gas can be used to determine the pressure under the mentioned restriction. One has to bear in mind that the viscosity depends on the kind of gas.

##### 5.2 Former constructions

To measure the viscosity of a gas one can use the measurement of the damping of any oscillating system. This idea is very old. Since the last century different types of gauges which used this principle were suggested. They contained an oscillating system [6], e.g. a pendulum of any shape (see Fig. 8a-c), which oscillated after a short excitation and whose damping was measured by noting the reduction of the amplitude with time. This procedure is not convenient and has the disadvantages that it is discontinuous and is disturbed by every kind of impact or vibration of the housing at which the pendulum is

fixed. Rotating oscillations (see Fig. 8d–e) were also used for the same purpose [7], but they had the same disadvantages. Therefore, in 1937 Holmes [8] suggested magnetic suspension of the moving system that was damped by the viscosity of the gas. The advantage of this equipment is that there is no mechanical connection between the housing of the gauge and the rotating or oscillating part.

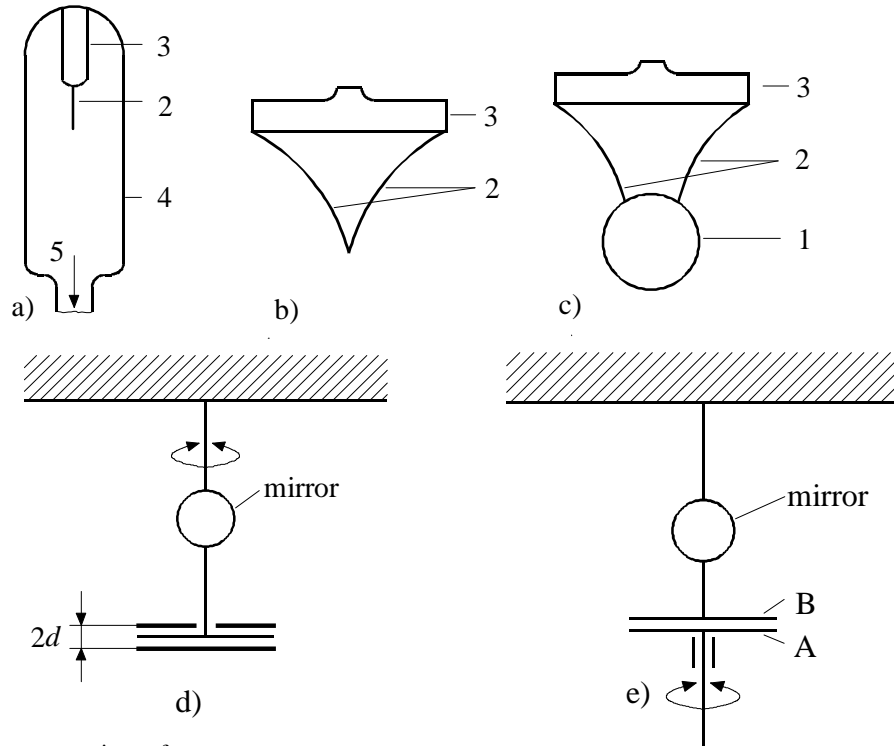
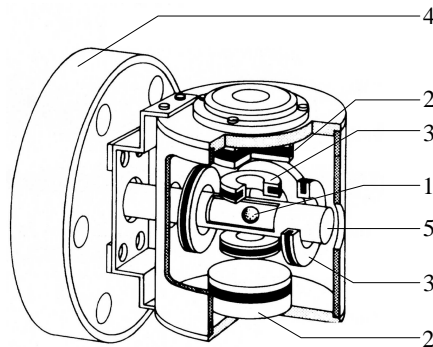

**Fig. 8** Former constructions of gauges:

- a) single-string pendulum (2), suspension (3), housing (4), connection to the chamber (5);
- b) double-string pendulum (2), suspension (3);
- c) double-string pendulum (2) with mirror (1), suspension (3);
- d) torsional vibration gauge with one moveable disc between two fixed discs;
- e) viscosity gauge with one rotating disc (A) opposite to movable suspended disc (B)

### 1.3 The spinning-rotor gauge

In 1968 Fremerey [9] developed a gauge with a freely-rotating steel ball for the measurement of the viscosity of the gas. According to Fig. 9 this ball (1) was suspended by permanent magnets (2) and magnetic coils (3) whose excitation current was electronically adjusted. The ball was made to rotate by a special coil. After reaching a desired frequency the excitation was stopped and the remanent magnetism of the ball induced an electric voltage in a coil so that the frequency could be determined electronically at intervals of time.



**Fig. 9** Spinning rotor gauge (after a data sheet of the Leybold company)

The viscosity and the pressure could be calculated from the decrease of the frequency  $\nu$  with time from

$$p = \frac{\pi \rho_K r \bar{v}}{10 \alpha t} \ln \frac{\nu(t)}{\nu(0)} \quad (9)$$

where  $r$  is the radius of the ball,  $\rho_K$  its density,  $\nu(t)$  frequency of the ball at the time  $t$ ,  $\nu(0)$  frequency at the beginning of the measurement,  $\alpha$  the accommodation coefficient and,  $\bar{v}$  is the arithmetic average velocity of the gas particles. The advantage of this gauge is the simple construction of the sensor. It consists only of a flange (4) connected with a cylindrical tube (5) closed at the end opposite to the flange and containing the ball. The arrangement of the permanent magnets and the coils is a separate structure fixed on the tube.

The lower pressure limit is  $10^{-7}$  mbar or lower, the upper pressure limit is about  $10^{-1}$  mbar. Due to the quantities  $\alpha$  and  $\bar{v}$  being specific to the gas the pressure reading depends on the composition of the gas. The precision of this gauge is so excellent that it can be used as a secondary standard for the calibration of other gauges.

#### 1.4 Miniaturization of viscosity gauges

Attempts have been made to miniaturize the dimensions of viscosity gauges by using oscillator quartzes made for temperature measurement or in wrist watches. Figure 10 shows the construction principle of the so called quartz friction gauge suggested by Ono and co-workers in 1986 [10, 11]. This equipment has the form of a tuning fork, but it is much smaller. It is made of quartz by lithographic processes similar to those used for the fabrication of semiconductor devices. Two specially shaped Au/Cr electrodes are deposited by sputtering on the surface of the tuning fork. The impedance of the capacitor formed by these two electrodes changes with the frequency and amplitude of the oscillations of this tuning fork and, in turn, is influenced by the ambient gas pressure. Thus, the change in impedance  $Z$  from the impedance for the resonance condition at very low pressures  $Z_0$  depends on the pressure. As an example, Fig. 11 shows the difference of the impedance ( $Z - Z_0$ ) vs. pressure for a fork length of 2.5 mm.

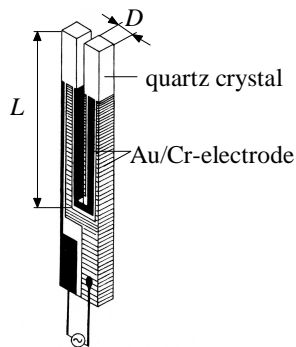

Fig. 10 Construction principle of the quartz friction gauge

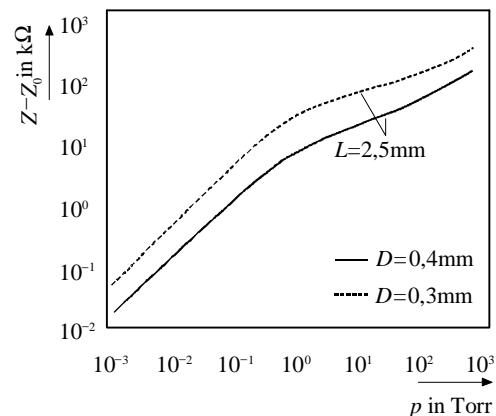

Fig. 11 Difference of the impedance ( $Z - Z_0$ ) vs. pressure for a fork length of 2.5 mm

## 6. GAUGES USING THE PRESSURE DEPENDENCE OF THE SPECIFIC HEAT CONDUCTIVITY OF THE GAS

### 6.1 The physical principle

Neglecting the disturbance of the thermodynamic equilibrium the kinetic theory of gases can be used to derive Eq. (11a) for the pressure dependence of the specific heat conductivity of a gas  $\lambda$  :



$$\lambda = \frac{1}{3} \Lambda \rho \bar{v} c_V . \quad (11 \text{ a})$$

with  $\Lambda$  the mean free path length of a gas particle,  $\rho$  the density of the gas,  $c_V$  the specific heat capacity of the gas at a constant volume, and  $\bar{v}$  the average value of the velocities of the gas particles. By comparison with Eq. (8) one can write for Eq. (11 a) :

$$\lambda = \eta c_V . \quad (11 \text{ b})$$

Considering the disturbance of the thermodynamic equilibrium by temperature gradients Chapman found a correction factor for Eq. (11 a or 11 b)

$$\lambda = 2,52 \eta c_V . \quad (11 \text{ c})$$

Independent of the special shape one can interpret Eq. (11a) in the following manner: The mean free path length of a gas is reverse proportional to the pressure, and the density is direct proportional to the pressure. Therefore, the specific heat conductivity of a gas does not depend on the pressure, because Eqs. (11a–11c) contain the product of  $\rho\Lambda$ . This statement is correct for higher pressures in the vacuum range, if the mean free path length  $\Lambda$  is lower than the geometric dimensions of the vacuum system. But if – as a consequence of lowering the pressure – the mean free path length reaches values of the same order of magnitude as the geometric dimensions of the system, the specific heat conductivity is diminished if the pressure is reduced. This effect can be used for the measurement of the pressure.

## 1.2 The general construction of a heat-conductivity gauge

Already in 1906 Pirani [12] suggested a gauge which used the pressure dependence of the heat conductivity for the pressure measurement.

In the simplest case the heat-conductivity gauge consists (Fig. 12) of a thin wire (diameter  $2r_i$ ) which is mounted in the axis of a cylindrical tube (diameter  $2r_o$ ). The cylindrical tube is connected with the vacuum chamber in which the pressure is to be measured. The thin wire is heated by a constant electric power  $P_{el}$ . Heat transport to the walls of the tube is caused by:

- conductivity through the electric feedthroughs  $I_{w1}$
- conductivity via the gas  $I_{w2}$
- radiation from gas  $I_{w3}$  .

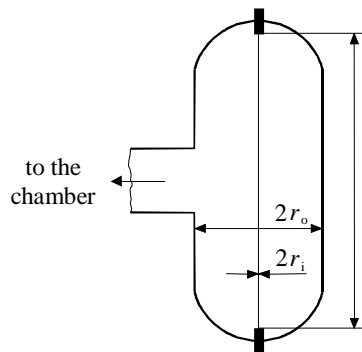

Fig. 12 General construction of a heat-conductivity gauge

At equilibrium:

$$P_{el} = I_{w1} + I_{w2} + I_{w3} = \sum I_W . \quad (12)$$

Heat transfer via the electric feedthroughs depends on the temperature of the heated wire, the material, and the cross section of the feedthroughs. Heat radiation is described by the law of Stefan and Boltzmann and depends on the fourth power of the temperatures of the heated wire and its surroundings. Both the term  $I_{w1}$  and  $I_{w3}$  are independent of gas pressure and nearly constant.

At higher pressures, when the mean free path  $\Lambda$  is small in comparison to the diameter of the wire, the specific heat conductivity of the gas is independent of pressure. Thus a constant heat flow is transported by the gas from the heater to the wall of the gauge. It depends only on the temperatures of the heater and of the walls and on the geometric structure, but not on the pressure. But if the pressure is diminished to values at which the mean free path  $\Lambda$  is in the order of the diameter of the thin wire, the heat conductivity of the gas decreases. Simultaneously the heat transport from the wire to the wall is reduced and the temperature of the wire rises if the electric power is constant. At very low pressures the heat flows  $I_{w1} + I_{w3}$  dominate and the heat flow via the gas can be neglected. Thus, the temperature of the heated wire becomes stable. This behaviour of the heat flow and the temperature of the heater operated with constant electric power is shown in Fig. 13. The pressure reading is transformed into the measurement of the heater temperature. This in turn is possible either by the determination of the electric resistance of the wire with the help of a Wheatstone bridge or by a thermocouple whose voltage is measured. Another possibility of measurement is to stabilize the temperature of the heater by variation of the heating power. At low pressure less electric power is necessary to obtain the desired heater temperature than at higher pressures.

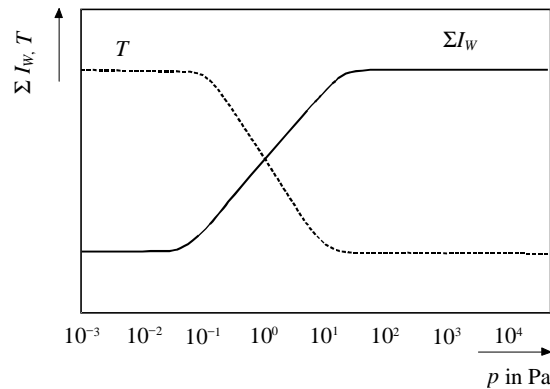

Fig. 13 Heat flow and temperature of a heater with constant electric power

As can be seen in Fig. 13, in the case of operation with constant heating power the pressure is correctly measurable only between  $10^{-3}$  mbar and 1 mbar. Above 1 mbar and below  $10^{-3}$  mbar, the output vs. pressure curve is so flat that a correct pressure reading is nearly impossible. To extend the range of pressure measurement to lower pressures one can reduce the term of the heat radiation by lowering the heater temperature (i.e. lower electric power) and by cooling the tube wall. Thus, it is even possible to measure with special gauges pressures of about  $10^{-4}$  mbar.

An extension of the range of higher pressures is also possible. For this purpose the heat transfer from the heater to the walls by convection can be used. This was shown by Gorski and co-workers in Poland [14].

The pressure reading depends on the kind of gas and on the accommodation coefficients of the heated wire and the inner tube wall. Thus, contamination of the tube wall or the heater surface can influence the pressure reading.

### 1.3 Miniaturization of heat-conductivity gauges

In principle it is possible to miniaturize the heat conductivity gauges by using technology used in the production of semiconductor components. For example Huang and Tong [15] have used a silicon chip with the dimension of only  $1.62 \times 2.02$  mm. The principle of this element is shown in Fig. 14. The heater consists of a resistor spread over the whole area of the chip. It is fed via a MOS transistor which regulates the current so that the temperature of the heater is always constant. (The heating increases the temperature of the whole chip whose temperature is somewhat higher than ambient.) The temperature is

measured by a diode and stabilized by a proper integrated circuit. The voltage of the heater is used for pressure measurement. Figure 15 shows schematically the characteristics of this gauge. At pressures lower than 1 mbar the heat conductivity, and above 1 mbar the heat convection, is used to measure the pressure.

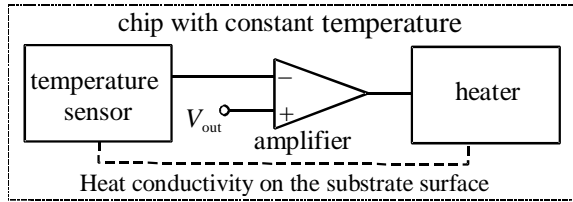

**Fig. 14** Principle of heat-conductivity gauge of Huang and Tong

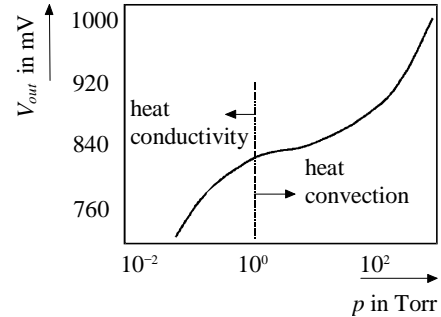

**Fig. 15** Characteristics of heat-conductivity gauge of Huang and Tong

Another possibility for miniaturization of the sensor was developed by Badinter and co-workers [13], who used a very small heater, but external circuits for the measurement. The gauge had a diameter of 3.6 mm and a height of 3 mm. The heater had a diameter of 6–7  $\mu\text{m}$  and was coated with an isolating film of 5–7  $\mu\text{m}$  thickness. The range of measurement was between 0.1 and 100 mbar.

## 7. RADIOMETER-EFFECT GAUGES

The thermal molecular pressure experimentally demonstrated by Crookes in 1873 was used by Knudsen [16] in 1910 for the measurement of pressures. To explain this effect we consider in Fig. 16 two plane-parallel plates 1 and 2 with the same area but different temperatures  $T_1$  and  $T_2$ . The distance  $d$  between the two plates may be small compared with the mean free path  $\Lambda$ , so that  $d < \Lambda/10$ . Assuming  $T_1 > T_2$  ( $T_2$  may also be the temperature of the surroundings) gas particles travelling from plate 1 to plate 2 have a higher impact than gas particles coming from the surroundings to the other side of plate 2. Thus, different pressures seem to act onto the two sides of plate 2. Their difference can be calculated with the help of the known laws of the kinetic theory of gases by the following equation:

$$\Delta p = \frac{p}{2} \left( 1 + \frac{\alpha_2 - \alpha_1}{\alpha_1 + \alpha_2 - \alpha_1 \alpha_2} \right) \left( \sqrt{\frac{T_1}{T_2}} - 1 \right) \quad (13)$$

where  $\alpha_1$  and  $\alpha_2$  are the accommodation coefficients of the plate 1 and 2 respectively. According to Fig. 17 one can suspend plate 2 in the manner used for galvanometers. The pressure difference effects movement of plate 2. The elastic moment of the suspension tries to compensate the momentum caused by the pressure difference at the two sides of plate 2. Thus, in the equilibrium the torsion of plate 2 indicates the pressure. Figure 18 shows the torsion angle  $\gamma$  vs. pressure  $p$ .

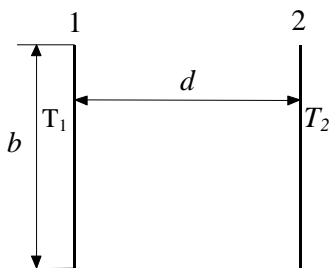

**Fig. 16** Principle of radiometer-effect gauge

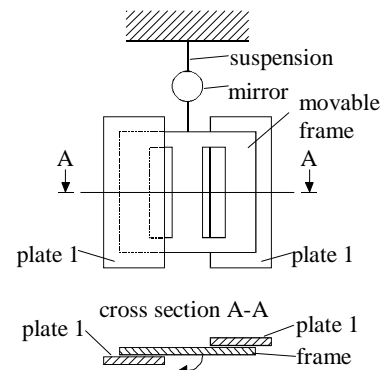

**Fig. 17** Construction of radiometer-effect gauge

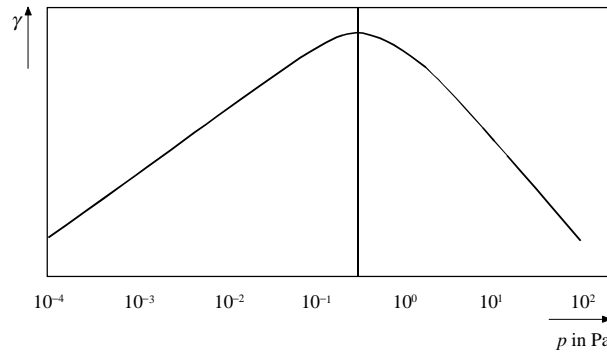

**Fig. 18** Torsion angle  $\gamma$  vs. pressure  $p$

According to Eq. 13 this method of pressure measurement is independent of the kind of gas. Some versions of this equipment have a low-pressure limit of about  $10^{-8}$  mbar [19]. Because this type of gauge is very sensitive to vibrations and impact it is not used industrially today.

## 8. GAUGES USING THE INTERACTION BETWEEN ELECTRONS AND GAS PARTICLES

Collisions between electrons and gas particles have the following effects:

- elastic scattering of the electrons
- inelastic scattering of the electrons connected with dissociation, excitation or ionisation of gas particles.

### 8.1 Gauges using the elastic electron scattering for pressure measurement

Gauges of this type can be used where the electrons have energies lower than the ionisation energy. In this case the probability for excitation is small and the probability for ionisation is zero.

If electrons are accelerated by a low-voltage, elastic collisions with gas particles cause the appearance of velocity components perpendicular to the direction of the electric field and the reduction of the accelerating effect in the electric field. In the worst case, the electrons can reach, in a homogeneous electric field, a constant drift velocity instead of an accelerated movement. Of course, these effects happen only if the gas pressure is high enough that the mean free path length of the electrons is much smaller than the distance between the electrodes producing the electric field. These effects can be used for pressure measurement.

In 1983 Lucas and Goto [18] used the appearance of velocity components of the gas particles perpendicular to a homogeneous electric field for pressure measurement. They found that electrons traveling in the direction of a uniform homogeneous electric field diffuse radially to the direction of this field. Electrons starting from a point source of the cathode arrive at the anode with a mean radial displacement  $\overline{r^2}$  whose magnitude can be expressed by the formula:

$$\overline{r^2} = 4 \frac{D_r}{\mu} \frac{d^2}{U} \quad (14)$$

with  $D_r$  the so-called radial-diffusion coefficient,  $\mu$  the mobility,  $d$  the distance between cathode and anode, and  $U$  the voltage between cathode and anode. The quotient  $D_r/\mu$  is solely a function of  $U/(pd)$  so that the mean radial displacement is a function of the pressure  $p$ .

The gauge of Lucas and Goto using this effect for pressure measurement has two anodes facing the cathode. One has the shape of a circular disc placed at a distance  $d$  from the cathode. The other is a flat ring surrounding concentrically the disc. The distribution of the electron current to these two anodes having the same potential can be used for pressure measurement. This type of gauge is shown schematically in Fig. 19.

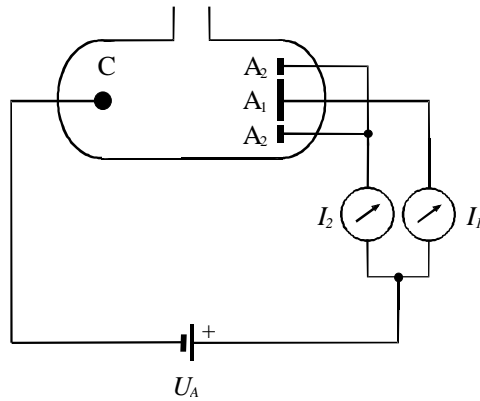

Fig. 19 Scheme of Lucas and Goto gauge

The pressure can be measured in a range between  $10^{-3}$  mbar and about 100 mbar. The curves of the current ratio vs. pressure are not linear. Their shape depends on the kind of gas. A linearization of these curves seems to be possible with the help of a microcomputer.

Another gauge construction was suggested by Edelmann in 1998 [18–21]. The original idea was to use the drift velocity  $u$  of the electrons in the homogeneous electric field for pressure measurement. Kapzov [22] has shown that the drift velocity  $u$  of electrons in a weak electric field depends on the pressure according to the formula:

$$u = \alpha \frac{e \Lambda_e}{m v} E, \quad (15)$$

where  $e$  is the elementary charge of an electron and  $\Lambda_e$  its mean free path,  $E$  the electrical field strength equal to voltage  $U/d$ ,  $m$  the mass of an electron, and  $v$  the (not exactly defined by Kapzov) average velocity of the electrons. The mean free path length of the electrons is inversely proportional to the pressure. Thus it should be possible to determine the gas pressure by the measurement of the drift velocity  $u$ . Originally, it was intended to determine the drift velocity by the measurement of the electron distribution onto two electrodes. For this purpose the gauge contained, instead of two flat anodes in one plane perpendicular to the axis between cathode and anode, a flat grid followed by a flat anode sheet as shown in Figs. 20a–c. Both electrodes are parallel and placed perpendicularly to the axis between the cathode and anode. They have the same voltage, about 10–20 V positive with respect to the cathode. The ratio of the electron current to the grid and the electron current to the anode plate can be used to determine the pressure. With this construction we have measured the pressure in the range between  $10^{-1}$  and 100 mbar. The characteristics of this gauge are shown in the Fig. 21. To read the pressure it is possible to use the ratio of the grid and the anode current, while the cathode current is kept constant, or to keep either the grid or the anode current constant and to use the current of the other electrode (i.e. anode or grid respectively) for pressure measurement.

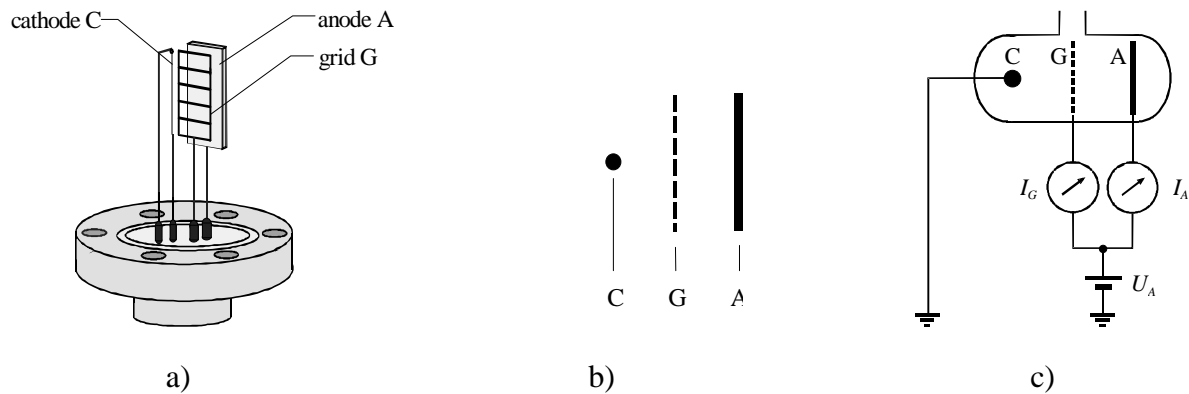
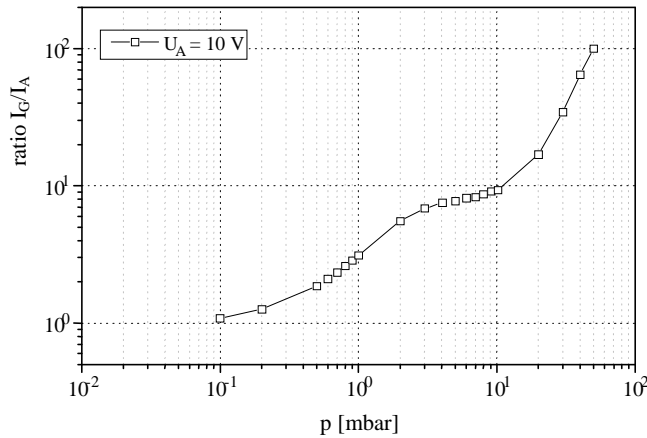

Fig. 20 Drift-velocity gauge



**Fig. 21** Characteristics of drift-velocity gauge

An attempt to calculate the distribution of the electrons to the two electrodes with the help of the classical methods used by Barkhausen or Rothe and Kleen for electron tubes does not give correct results. The reason may be that these methods neglect increasing velocity components perpendicular to the direction of the homogeneous electric field with increasing pressure.

Thus, for a better calculation of the current distribution only Monte Carlo calculations seem to be possible. These were performed by Kauert with the aim to optimise and to miniaturize the electrode structure.

The advantages of these types of gauges are:

- Large range of pressure measurement from  $10^{-3}$  mbar (or even  $10^{-4}$  mbar) to about 100 mbar .
- Fast response for pressure changes, much faster than for example diaphragm gauges.
- Possibilities to miniaturize the gauges.
- Simple electronic circuits.

Disadvantages are:

- As in the case of viscosity and thermal-conductivity gauges the pressure reading depends on the kind of gas.

However the most important problem for this type of gauge is the electron source. Lucas and Goto used a photo cathode illuminated by ultraviolet light. This is not convenient for practical applications. We used a directly-heated iridium cathode coated with yttrium oxide. In the rough vacuum range the lifetime of such a cathode is limited. It is hoped that field emitter arrays or sandwich cathodes will have a longer lifetime and will be commercially available for this purpose in the near future.

## 1.2 Gauges using the inelastic interaction between electrons and gas particles

The energy loss of electrons by inelastic collisions with gas particles can cause an *excitation of the gas particles*. The excited particles return immediately into the ground state by radiation of electromagnetic waves. Although the light emission of gas discharges can be used for a rough estimation of the pressure range, and in some cases even for information about special components of the gas mixture, this effect is not suitable for exact pressure measurement. But the energy loss of electrons can also effect the ionization of gas particles. The use of the gas ionization for pressure measurement was discovered in connection with the development of electron tubes at the beginning of this century. Today it is widely used for pressure measurement in the so called ionization gauges. These gauges are described in another chapter of these proceedings.

## 9. SURVEY OF THE OPERATIONAL RANGES OF VACUUM GAUGES

As a short summary in Table 2 are put together the operation ranges of the different gauges for the measurement of total pressures (ionization gauges are excluded).

Table 2

Short summary of the operational ranges of different gauges for the measurement of total pressures  
(X, pressure reading is independent of the kind of gas; O, pressure reading depends on the kind of gas)

Name of the Range	Extreme High Vac.		Ultra-High Vacuum					High Vacuum				Medium Vacuum			Rough Vacuum		
	-14	-13	-12	-11	-10	-9	-8	-7	-6	-5	-4	-3	-2	-1	0	1	10
log (p/mbar)																	
Piston gauges													xxx	xxx	xxx	xxx	xxx
Bourdon gauges																xxx	→
Diaphragm gauges											xxx	xxx	xxx	xxx	xxx	xxx	
Piezoresistive diaphragm gauges														xxx	xxx	xxx	→
U-Tube Gauge															xxx	xxx	→
McLeod Gauge									xxx	xxx	xxx	xxx	xxx	xxx	xxx	xxx	xxx
Modulation Gauge									ooo	ooo	ooo	ooo	ooo	ooo	ooo	ooo	ooo
Spinning Rotor Gauge								ooo	ooo	ooo	ooo	ooo	ooo				
Pirani Gauge												ooo	ooo	ooo			
Radiometer Gauge							(xx)	xxx	xxx	xxx	xxx	xxx	xxx	xxx			
Radial Drift Gauge																ooo	ooo
Elastic Scattering Gauge											(?)	(?)	(?)	ooo	ooo	ooo	ooo

## 10. ACKNOWLEDGEMENTS

The author is grateful for the careful support in many technical activities of Mrs. U. Lehmann and Mr. Dipl.-Phys. Hauer. Both were very helpful in accurately preparing the manuscript and the slides for this lecture.

## 11. REFERENCES

### 11.1 General Reviews

S. Dushman, J.M. Lafferty : "SCIENTIFIC FOUNDATION OF VACUUM TECHNIQUE", John Wiley and Sons, Inc. New York, London, 1962

J.M. Lafferty (ed.) : "FOUNDATIONS OF VACUUM SCIENCE AND TECHNOLOGY", John Wiley & Sons, Inc. New York , Toronto 1997

- Chr. Edelmann, H.-G. Schneider (editors) : "Vakuumphysik und -technik", Akademische Verlagsgesellschaft Geest & Portig K.-G., Leipzig, 1978
- Chr. Edelmann: "Vakuumentchnik : Grundlagen und Anwendungen", Hüthig-Verlag, Heidelberg, 1985
- Chr. Edelmann : "Vakuumphysik : Grundlagen, Vakuumerzeugung und -messung, Anwendungen", Spektrum Akademischer Verlag Heidelberg, 1998

## 11.2 Special Papers

- [1] B. van Zyl : Check on the Linearity of a Capacitance Diaphragm Manometer between  $10^{-4}$  and  $10^{-1}$  Torr, Rev. Sci. Instrum. 47 (1976) 9, 1214
- [2] Catalogue of the company LEYBOLD AG, HV 300, Part A1, date of publication: 05/92, pages 18 and 76/77
- [3] H. McLeod, Apparatus for Measurement of Low Pressures of Gas, Phil. Mag. 48 (1874), 110
- [4] R. Jurgeit, C. Hartung: Vorrichtung zur kontinuierlichen Messung von Gasdrücken. Wirtschaftspatent der DDR WP G 01 L/197067 Nr. 130850 vom 25 01 1977, erteilt am 3 5 1978
- [5] R. Jurgeit, Dissertation, Technische Universität Dresden, 1981
- [6] Chr. Edelmann: Stand und Entwicklungstendenzen der Totaldruckmessung in der Vakuumtechnik. Vakuum-Techn. 34 (1985) 6, 162 - 180
- [7] R. Jaeckel: "Kleinste Drucke, ihre Messung und Erzeugung", Springer-Verlag, Berlin Heidelberg 1952
- [8] F. T. Holmes: Rev. Sci. Instr. (1937) , 444
- [9] J. K. Fremerey : High Vacuum Friction Manometer, J. Vacuum Sci. Technol. 9 (1972) 108
- [10] T. Kobayashi, H. Hojo, M. Ono: Gas Concentration Analysis with a Quartz Friction Vacuum Gauge. Vacuum 47 (1996) 6/8, 479 - 483
- [11] M. Ono, M. Hirata, K. Kokubun, H. Murakami: Quartz Friction Vacuum Gauge for Pressure Range from 0.001 to 1000 Torr. J. Vac. Sci. Technol. A 4 (1986) 3, 1728 - 1731
- [12] M. Pirani. Ber. Dt. Phys. Ges. 4 (1906), 686
- [13] E. Ja. Badinter, B.K. Zalewskii, I. G. Starusch: A Miniaturised Thermo-electric Pressure Gauge (in Russian), Prib. Tekh. Eksp. (1980), 248 - 250
- [14] W. Gorski, A. Smiech: Convection Vacuum Gauge for Use Between  $10^{-3}$  and 760 Torr, Le Vide No. 169 (1974), 221
- [15] J.B. Huang, Q. Y. Tong : Constant Temperature Integrated Vacuum Sensor, Electron Lett. 24 (1988) 23, 1429 - 1430
- [16] M. Knudsen: Ein absolutes Manometer. Ann. Phys. 32 (1910) 809 -842
- [17] H. Klumb, H. Schwarz : Über ein absolutes Manometer zur Messung niedrigster Drücke, Z. Phys. 122 (1944), 418
- [18] J. Lucas, T. Goto: A Pressure Gauge Utilising the Electron Diffusion Process and Microcomputer Control, Vacuum 34 (1984) 785 - 789
- [19] Chr. Edelmann: Vakuum-Meßverfahren und Vakuum-Meßeinrichtung, Deutsches Patentamt, 02.12.1998
- [20] Chr. Edelmann: Vakuum-Meßeinrichtung, Deutsches Markenamt, angemeldet 02.12.1998
- [21] Chr. Edelmann, R. Kauert, St. Wilfert: Anwendung der Elektronendriftgeschwindigkeit zur Druckmessung, Frühjahrstagung der Deutschen Phys. Ges. Münster, 1999
- [22] N.A. Kapzow: "Elektrische Vorgänge in Gasen und im Vakuum" (German translation from Russian), VEB Deutscher Verlag der Wissenschaften Berlin 1955



