

# LATEST DEVELOPMENTS FROM THE S-DALINAC\*

M. Brunken, H. Genz, M. Gopych, H.-D. Graef, S. Khodyachykh, S. Kostial, U. Laier, A. Lenhardt, H. Loos, J. Muehl, M. Platz, A. Richter, S. Richter, B. Schweizer, A. Stascheck, O. Titze, S. Watzlawik (TU Darmstadt), S. Doebert (CERN)

## Abstract

The S-DALINAC is a 130 MeV superconducting recirculating electron accelerator serving several nuclear and radiation physics experiments as well as driving an infrared free-electron laser. A system of normal conducting rf resonators for noninvasive beam position and current measurement was established. For the measurement of gamma-radiation inside the accelerator cave a system of Compton-diodes has been developed and tested. Detailed investigations of the transverse phase space were carried out with a tomographical reconstruction method of optical transition radiation spots. The method can be applied also to non-Gaussian phase space distributions. The results are in good accordance with simulations. To improve the quality factor of the superconducting 3 GHz cavities, an external 2K testcryostat was commissioned. The influence of electrochemical polishing and magnetic shielding is currently under investigation. A digital rf-feedback system for the accelerator cavities is being developed in order to improve the energy spread of the beam from the S-DALINAC.

## 1 INTRODUCTION

A comprehensive discussion of the layout and the properties of the recirculating superconducting electron accelerator S-DALINAC is given in [1]. The electrons are emitted by a thermionic gun and then accelerated electrostatically to 250 keV. A normal conducting 3 GHz chopper-prebuncher system creates the required 3 GHz time structure of the beam. An additional subharmonic 600 MHz chopper/buncher allows for a 10 MHz bunch repetition rate for FEL operation. The superconducting injector linac consists of one 2-cell capture cavity ( $\beta=0.85$ ), one 5-cell cavity ( $\beta=1$ ), and two 20-cell cavities operated in liquid helium at 2 K. The electron beam behind the injector with a maximum energy of 10 MeV can either be directed to a first experimental site or it can be injected into the main linac. There, eight 20-cell cavities provide an energy gain of up to 40 MeV. When leaving the main linac, the beam can be extracted to the experimental hall or it can be recirculated and reinjected one or two times. The maximum beam energy after three passes through the linac amounts to 130 MeV. An infrared FEL with wavelengths between 3 and 10  $\mu\text{m}$  is driven by the electron beam with an energy from 25 up to 50 MeV.

For the different experiments, a beam current from some

nA up to 60  $\mu\text{A}$  can be delivered. In the subharmonic injection mode, a peak current of 2.7 A can be passed through the FEL undulator.

## 2 BEAM- AND POSITION MONITORS

A combination of normal conducting  $\text{TM}_{010}$ - and  $\text{TM}_{110}$ -cavities as displayed in fig. 1 was recently developed for the S-DALINAC to measure the beam intensity and position. The cavities are fabricated from stainless steel, they have a common centerpiece and two covers which connect to the beam line. The rf outputs use ceramic feedthroughs. The monitors are operated at loaded Qs of less than 1000. Thus, they need no frequency or temperature stabilization.

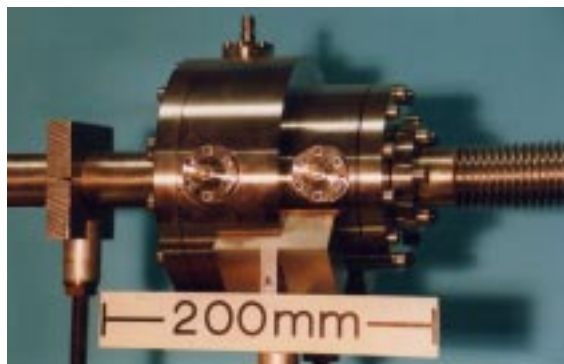

Figure 1: Non intercepting 3 GHz rf monitor.

The sensitivity is 15 nW/ $(\mu\text{A})^2$  for the intensity monitor and 15 pW/(mm  $\mu\text{A})^2$  for the position monitor. For the detection of the rather low signals, lockin techniques are used. Dedicated electronics close to the monitor convert the signal to a dc voltage, enabling even the measurement of a 0.1 mm beam position change at a beam current of 1  $\mu\text{A}$  or a 10 nA current change. Seven monitor units have been installed in different sections of the accelerator. The monitor signals can be displayed graphically in the S-DALINAC control room.

## 3 COMPTON-DIODES

For a detailed examination of effects of the bremsstrahlung background in the accelerator cave on accelerator system components, a monitoring system has been constructed and is currently being tested. The layout of the bremsstrahlung monitors (also referred to as Compton-diodes) is shown in fig. 2. They consist of an inner lead electrode and an outer

\*Supported by DFG under contract no. FOR 272/2-1 and Graduiertenkolleg "Physik und Technik von Beschleunigern"

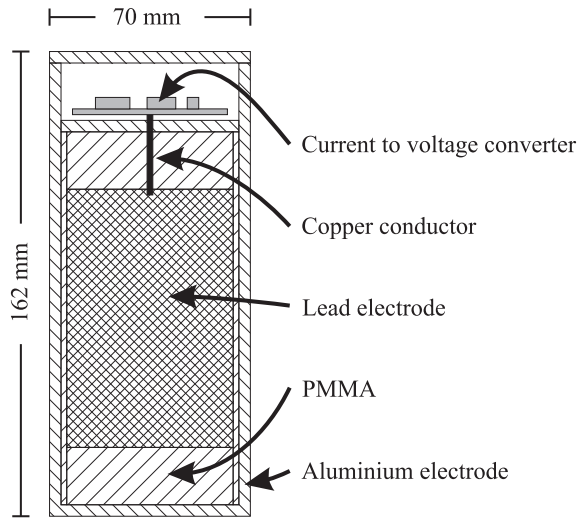

Figure 2: Layout of a Compton-diode.

aluminium electrode insulated by plexiglas. Due to the different Compton cross sections of the electrodes, a photon beam penetrating the monitor creates a small current between the electrodes, typically several pA for a dose rate of 10 mSv/hr. This current is converted to a voltage, amplified and read out via ADCs. The linearity of the output voltage over the photon flux was demonstrated at a radiation physics setup behind the injector. The electrons were targeted onto a copper bremsstrahlung converter, the resulting gamma beam was collimated by a copper collimator. Figure 3 shows the monitor output voltage as a function of the electron current on the converter target. The Compton diodes are very rugged and form a flexible system which can monitor any location outside the beam pipe. Thus radiation impact on accelerator components can be measured and beam losses can be detected.

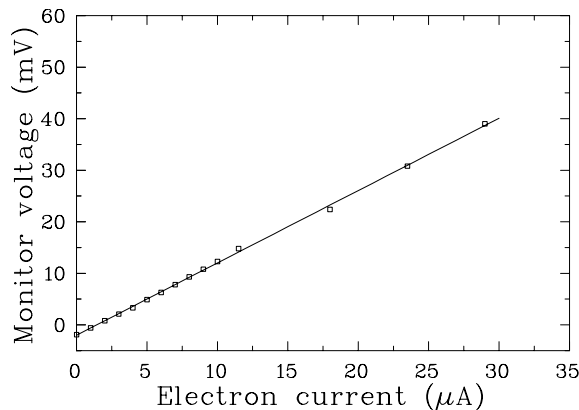

Figure 3: Linearity of the Compton-diode shown in fig. 2.

## 4 TRANSVERSE PHASE SPACE TOMOGRAPHY

The method of transverse phase space tomography [2] has been applied to the electron beam behind the injector of the S-DALINAC. The setup shown in fig. 4 consists of an optical transition radiation (OTR) target, a CCD camera and a PC with a framegrabber board. Two quadrupoles have been used to change the beam transport matrix accordingly. A computer code written in the Interactive Data Language (IDL) reconstructs the transverse phase space with a tomographical algorithm. The advantage of this method is the capability of reconstructing the phase space distribution without assuming any particular shape.

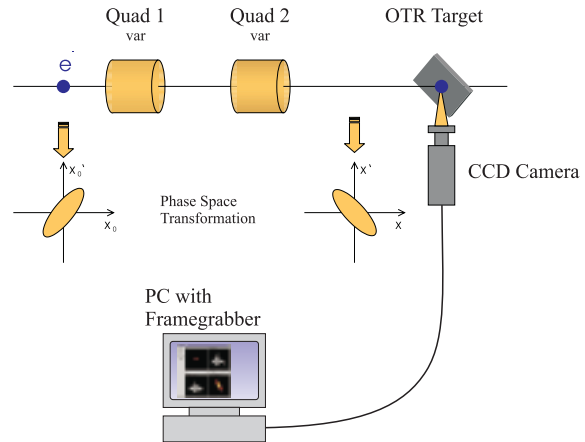

Figure 4: Set up for phase space tomography.

The accuracy of the reconstruction algorithm was tested by simulations. A total of 18 projections of a non-symmetric distribution interpolated to 90 projections lead to a reconstruction result with an emittance error of less than 15%. First measurements with an 8 MeV electron beam showed good agreement of the so determined emittance with the one from the common method.

## 5 Q-VALUE OF THE ACCELERATOR CAVITIES

The accelerator cavities used at the S-DALINAC are operated at 2 K, the frequency of the  $\pi$ -mode, used for acceleration is 2.997 GHz. The design parameters of the 1 m long 20-cell cavities consisting of niobium (RRR=280) assumed an unloaded quality factor of  $3 \cdot 10^9$  and an accelerating gradient of 5 MV/m. Almost all gradients achieved during routine operation exceed this design criteria, some resonators reach up to 10 MV/m. On the other hand, although different preparation techniques have been tested, currently none of the cavities has achieved a Q-value significantly higher than  $1 \cdot 10^9$ . The reduction of the Q-values in comparison with the design criteria increases the dissipated power per cavity from 4.2 to 12.6 W. As a consequence the maximum energy of the S-DALINAC in the cw-mode is limited by the installed He-refrigerator power. A measurement of the

quality factor as a function of temperature has revealed that the resonators have a residual resistance of 276 n $\Omega$  compared to the BCS-resistance of 50 n $\Omega$  at 2 K.

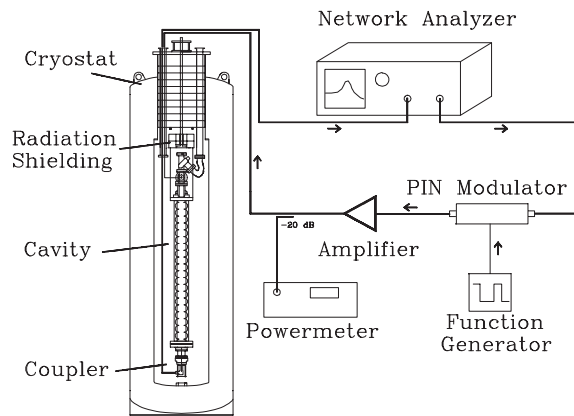

Figure 5: Layout of the external 2 K testcryostat.

In order to find an explanation for this behaviour a vertical 2 K testcryostat was turned into operation (see fig. 5). This test setup allows to perform systematic studies without interfering with accelerator operation. We intend to develop an improved magnetic shielding for the cavities which takes the constraints of the complicated geometry (couplers, tuners) better into account than the present shielding. Additionally, systematic studies on the influence of different surface and material preparation methods on the Q-value are planned.

## 6 DIGITAL RF-CONTROL SYSTEM

The superconducting accelerator cavities have to be controlled to an rf phase error of less than 1 $^\circ$  and a relative amplitude error of less than  $\pm 1 \cdot 10^{-4}$ . The present analog control system fulfills the phase specifications, but it does not quite meet the amplitude specifications and it does not allow the use of modern digital control methods or detailed control data analysis. Figure 6 displays the schematic layout of a new digital control system which is currently under development in cooperation with DESY, Hamburg [3]. The 3 GHz signal extracted from a sc cavity is converted down to an intermediate frequency of 250 kHz. An ADC samples this signal at a rate of 1 MHz yielding a complex field vector. A digital signal processor (DSP) using techniques like feed forward tables creates a new output field vector. This vector is converted by DACs and mixed up to 3 GHz, amplified by klystrons and fed into the cavity. The remaining energy spread of the electron beam should be smaller by a factor of three with the new system.

## 7 CONCLUSION

At the S-DALINAC, several improvements were made with respect to beam diagnostics. Especially the rf intensity and position monitors as well as the Compton diodes will give substantial aid in linac operation. The tomographical phase

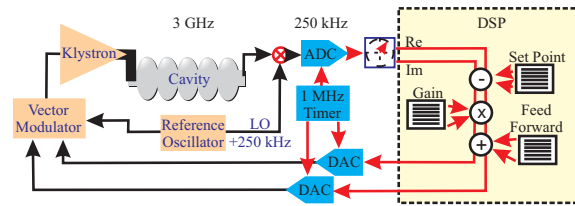

Figure 6: Digital rf-control system.

space reconstruction will provide more detailed information on the electron beam structure. The studies on cavity Q-values will hopefully result in a higher average Q, thus enabling a higher achievable beam energy. The new digital rf system should reduce the energy spread of the beam and improve the stability of accelerator operation.

## 8 REFERENCES

- [1] A. Richter, Operational Experience at the S-DALINAC, Proc. of the 5<sup>th</sup> Europ. Particle Accelerator Conf., Eds. S. Myers et al., IOP Publishing, Bristol, (1996) 110
- [2] C.B. McKee, P.G. O'Shea, J.M.J. Madey, Phase space tomography of relativistic electron beams, Nucl. Instr. and Methods in Physics Research A358, (1995) 264
- [3] T. Schilcher, Vector Sum Control of Pulsed Accelerating Fields in Lorentz Force Detuned Superconducting Cavities, DESY Print TESLA 98-29, (1998)