

Study of the quantum efficiency of CsI photocathodes exposed to oxygen and water vapour

A. Di Mauro, P. Martinengo, F. Piuz, E. Schyns^{*},
J. van Beelen, T.D. Williams

CERN, Geneva, Switzerland

for the ALICE Collaboration

Abstract

The operation of CsI photocathodes in gaseous detectors requires special attention to the purity of the applied gas mixtures. We have studied the influence of oxygen and water vapour contaminations on the performance of CsI photocathodes for the ALICE HMPID RICH prototype. Measurements were done through comparison of Cherenkov rings obtained from beam tests. Increased levels of oxygen and water vapour did not show any effect on the performance. The results of this study found a direct application in the way of storing CsI photocathodes over long periods and in particular in the shipment of the HMPID prototype from CERN to the STAR experiment at BNL.

1 Introduction

The High Momentum Particle IDentification (HMPID) system of ALICE at LHC is based on a CsI-RICH detector, aiming at charged $\pi/K/p$ identification in the 1.5-5 GeV/ c momentum range [1]. The use of CsI photocathodes (PCs) in gaseous detectors requires special attention to the purity of the gas. CsI is known to be very hygroscopic and exposure to air should be avoided. Humidity will produce a degradation of the quantum efficiency (QE) of the CsI film by hydrolysis of the material surface. The adsorption of O_2 may affect the photoemission, probably due to an increase of the electron affinity [2].

The influence of the exposure to O_2 and H_2O was investigated in two ways: 1) under stagnant conditions, through increased levels of O_2 and H_2O due to outgassing from the surfaces of the PC container (vessel or chamber); 2) under gas flow, with large concentrations of O_2 in the detector gas mixture.

Fig.1 shows a scheme of the dedicated CsI PC outgassing setup, consisting of H_2O - and O_2 -monitors, a CsI PC, a pad plane without CsI (defined as “Virgin

^{*} Corresponding author

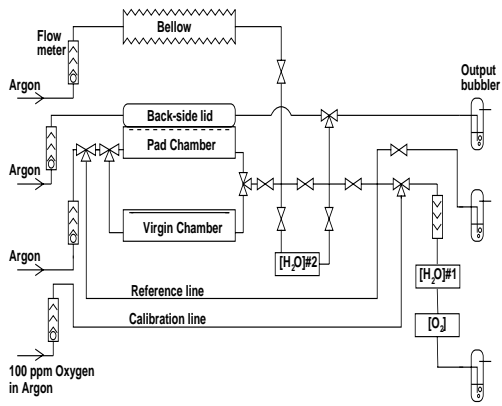

Fig. 1. The CsI PC outgassing test setup.

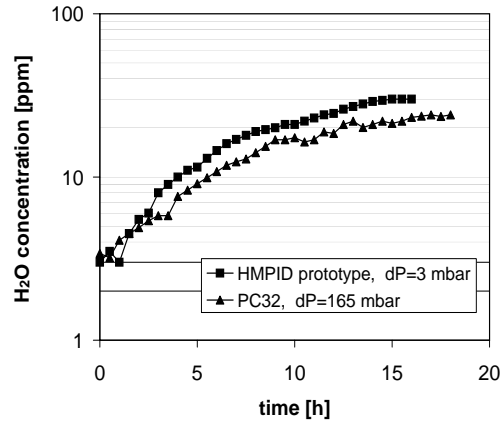

Fig. 2. Outgassed H₂O versus time

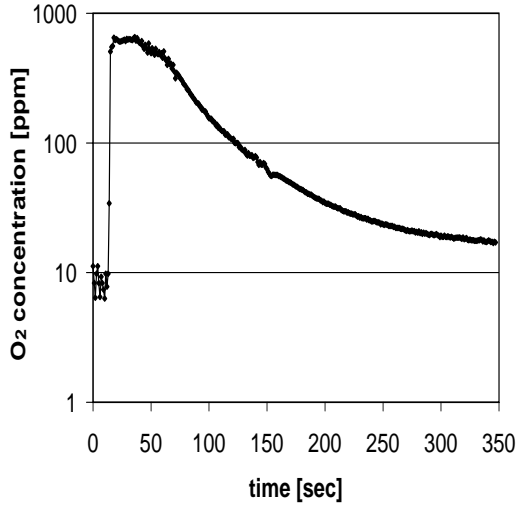

Fig. 3. PC24, output O₂ after 2 h stag-

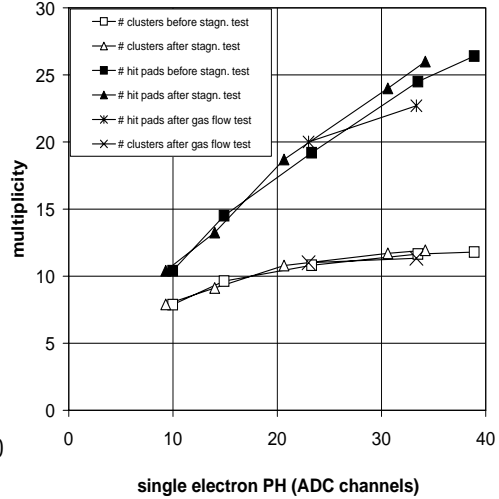

Fig. 4. Single electron average PH versus multiplicity before and after the tests.

Chamber”) and an inox bellow with an equivalent volume. The latter two were included for comparative measurements. One H₂O-sensor (#2) is used for in situ monitoring of the outgassing under stagnant conditions. The O₂ sensor can be operated with gas flow only. The monitoring is computerised by a LabView application. The PCs performance before and after exposure was measured in beam tests. The test beam setup and the HMPID are described in [1,3]. The HMPID prototype contains 4 PCs of 64x40 cm² and PC24 is 32x30 cm².

2 Results and discussion

Fig.2 shows the increase in time of the H₂O concentration during stagnancy test for PC32 and the HMPID prototype (at room temperature). PC32 was put at an overpressure of 165 mbar to ensure no external contributions due to possible micro-leaks. In both cases a plateau is reached after approximately 15 h. Fig.3 shows the O₂ concentration measured at the gas outlet of PC24 after a 2 h stagnancy. Time 0 corresponds to the restart of the Ar flow at 50 l/h.

The sharp rise of the concentration after 15 s, to a plateau of ~ 650 ppm, corresponds to the “pure” stagnant gas being purged out of the chamber. The exponential decrease due to mixing with Ar starts after about one volume exchange.

Beam tests with 3 GeV/c π^- were performed before and after the following conditions:

- 1) 24 h stagnant test of PC24, outgassing 10000 ppm O₂ and 40 ppm H₂O;
- 2) Gas flow test of PC24 under Ar/dry air mixtures with 18000 ppm O₂ for 6 h and 18 h and with 100000 ppm O₂ for 6 h;
- 3) 16 h stagnant test of HMPID prototype, 30 ppm outgassed H₂O (Fig.2).

Test beam data were analysed with the support of a Monte Carlo detector simulation allowing to deduce the PC QE [4]. Fig.4 shows the variation of the main quantities of the Cherenkov ring analysis with the single electron average PH (1 ADC ~ 0.17 fC), before and after the exposures. The outgassing from the surfaces inside either the PC container or the HMPID prototype has not affected the CsI QE. No degradation of the photoemission has been observed in any of the described experimental conditions.

3 Shipment of large CsI PCs to BNL

The results of this study found a direct application in the way of storing CsI photocathodes over long periods. In the summer 1999, the HMPID prototype was shipped from CERN to BNL for installation in the STAR experiment at RHIC. The four PCs were stored in separately sealed containers, which in turn were arranged in a stack and placed inside a cylindrical vessel. Both the containers and the vessel were pressurised with Ar at 1.2 bar before the shipment, to account for the change of the outside pressure during the transport by plane from Geneva to Brookhaven.

4 Acknowledgements

We thank Y. Andres, M. Davenport, B. Lasiuk, E. Nappi and G. Paic for their help and support.

References

- [1] ALICE HMPID Technical Design Report, CERN/LHCC 98-19,
- [2] A. Breskin, Nucl. Instr. and Meth. A 371 (1996) 116-136,
- [3] F. Piuz et al., Nucl. Instr. and Meth. A 433 (1999), 222-234,
- [4] A. Di Mauro et al., Nucl. Instr. and Meth. A 433 (1999), 190-200.