



ISTITUTO NAZIONALE DI FISICA NUCLEARE

Sezione di Genova

INFN/AE-00/05

18 Maggio 2000

**STRESS ON COLD MASS DUE TO THE SUPPORTING SYSTEM
OF THE CMS COIL IN THE VACUUM TANK**

S. Farinon, P. Fabbriatore.

INFN-Sezione di Genova, Via Dodecaneso 33, I-16146 Genova, Italy

Abstract

This report contains a verification analysis of the stress on cold mass coming from the supporting system of the CMS coil in the vacuum tank. The need to carry out this analysis is related to the high mechanical requirements for Al-alloy mandrels (218 MPa yield at cryogenic temperature), demanding accurate analysis of the impact of supporting system on cylinder stress.

*Published by SIS-Pubblicazioni
Laboratori Nazionali di Frascati*

1 INTRODUCTION

The aim of this work is to verify the support system of the CMS magnet, which has to ensure the suspension of the cold mass inside the vacuum tank. Particularly, the need to carry out this analysis is related to the high mechanical requirements for Al-alloy mandrels (218 MPa yield at cryogenic temperature), demanding accurate analysis of the impact of supporting system on cylinder stress. The support system is shown in Fig. 1; it consists of a set of radial and longitudinal rods, different in length and radius, made from titanium alloy (TAE5E eli).

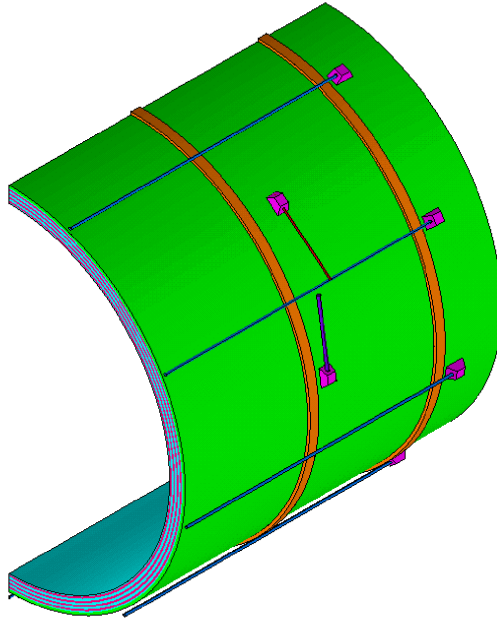

FIG. 1: View of the CMS magnet supporting system ($\frac{1}{4}$ symmetry).

The support system should sustain the following loads, applied subsequently:

- the solenoid weight (~225 tons) at room temperature;
- the solenoid weight at cryogenic temperature (4 K);
- the solenoid energisation (@ 4 K, 4 T);
- the solenoid vertical, horizontal and tilt misalignments.

For each load, the mechanical analysis has been performed into two steps: first, a simple hyper-static analysis has been carried out in order to have a rough estimation of the strains the tie-rods have to undergo. Secondly, a complete finite element analysis (FEA) is needed to understand the stresses induced on the mandrel. This study has been performed by the finite element code ANSYS[®].¹⁾

The stress distribution induced on shoulders as well as the impact on stress due to cryostat deformations have been treated separately, respectively in §4 and §5.

1.1 Solenoid weight

In the FE analysis, this load is simply simulated by applying the gravity acceleration to the 3D model, once the material densities and Young modulus are defined.

1.2 Cool down

The cool down is applied by specifying the reference temperature (300 K) and the final temperature (4 K), and defining for each material the coefficient of thermal expansion, which has been supposed to be constant.

1.3 Solenoid energisation

To simulate the solenoid energisation by FE analysis, first a 2D magnetic analysis was performed, in order to evaluate the axial and radial magnetic forces and their distribution along the solenoid. Those forces, applied to the 3D mechanical model, give the stresses due to the energisation. Their total value corresponds to ~15000 tons axially, for each side of the coil, and ~160000 tons radially.

1.4 Solenoid misalignments

The requirement for the CMS cold mass is that the solenoid axis must lie within a cylinder 10 mm in radius and 12.5 m in length. This implies 10 mm as maximum radial and axial displacements, and 5 minutes of angle as maximum tilt. The calculation of the forces and momentum corresponding to the maximum allowable misalignments has been performed by S. Klioukhine *et al.*²⁾ The results are summarized in the following table.

TAB. 1: Forces and momentum corresponding to the maximum allowable misalignments.

Misalignment	Resulting force [KN/cm]	Resulting momentum [t·m / mrad]
10 mm axially	843	—
10 mm radially	59	—
5 min tilt	—	914

Due to the complexity of the model, which contains about 120000 nodes in ¼ symmetry, the stress distribution due to solenoid misalignments will not be calculated. Anyway, an evaluation of those stresses has been already done by C. Pes.³⁾ The main result is that the maximum allowed misalignments do not sensitively modify the stress level reached after the energisation of CMS magnet, on any component of the magnet itself.

2 EFFECT OF AXIAL TIE-RODS

Fig. 2 schematizes the actual longitudinal supporting system of the coil. 18 TA5E tie rods (5420 mm in length, 45 mm in diameter) support axially the coil (9 rods each side axially, one every 40° circumferentially). The rods are firmly connected to the vacuum vessel at one side and at the module CB0 on the opposite side. The axial distance between the shoulders of opposite rods on CB0 is 1800 mm.

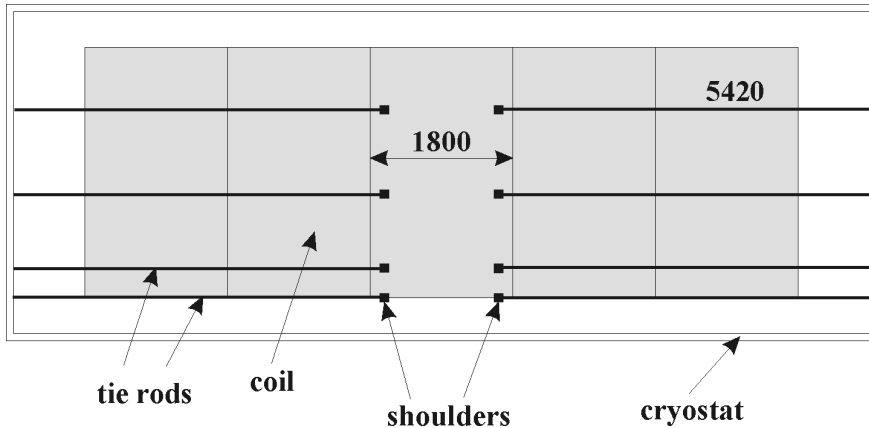

FIG. 2: Scheme of longitudinal supporting system.

2.1 Hyper-static analysis

As first step, we carried out simple consideration not involving FE analysis to understand the order of magnitude of stress in tie-rods and possible effects on cold mass. Obviously, the solenoid weight has no impact on the longitudinal rods.

2.1.1 Cooling down

When the coil is cooled-down to 4.5 K, the axial distance between the shoulders of the axial rods decreases of $1800 \times 4.3 \cdot 10^{-3} = 7.74$ mm. This means that each rod is strained in tension by 3.87 mm (equivalent to $714 \mu\epsilon$). We have to add the thermal contraction of the rods, which, taking into account the 300 to 4.2 K gradient, has been evaluated to be $3.1 \cdot 10^{-6} \text{ K}^{-1}$, i.e. 4.97 mm (equivalent to $917 \mu\epsilon$). Totally, we have a rod strain of $1631 \mu\epsilon$. Considering that the Young modulus ranges between 110 and 140 GPa (in between 300 K and 4.2 K), we have a rod stress ranging between 180 MPa (on the warm end) and 230 MPa (on the cold end) in tension. Related to this stress we must have a corresponding localized stress on the cylinder, which can be only evaluated through a FE analysis.

2.1.2 Solenoid energisation

When charging the coil at nominal field, we have on the coil an axial compression. According to the 2D results mentioned in the introduction, the charge causes an axial strain of about $800 \mu\epsilon$. This means that the distance between axial shoulders is furtherly decreased by 1.44 mm. Then each tie rod is straightened by $133 \mu\epsilon$, bringing the total

stress to $230 + 20 = 250$ MPa in tension (at cold end). This would give a small effect on cold mass with respect the stress due to cool-down.

2.2 FE analysis

2.2.1 3D model

The coil and supporting systems have been 3D modeled, as shown in Fig. 3. The coil is modeled by subsequent layers, in the radial direction, of aluminum alloy and pure aluminum, the latter described by plastic stress-strain curve. The shoulders are modeled with no filleted areas.

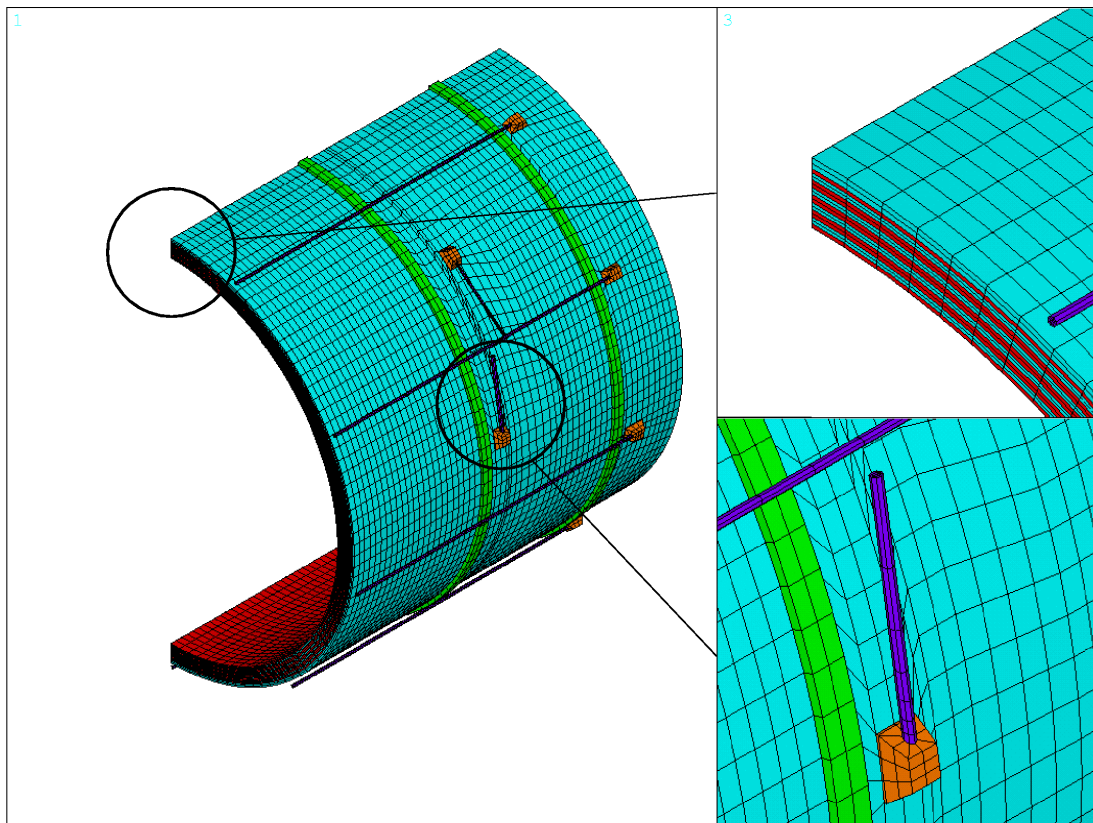

FIG. 3: 3D FEA model.

2.2.2 Cool down

The effect of the cool-down is to put in tension the tie-rods up to 235 MPa, in good agreement with the results coming from the simple model (230 MPa). Consequently, the cylinder will be stressed in the region of the shoulders. Fig. 4 shows the Von Mises stress on the mandrel excluding the shoulders due to longitudinal tie rods. The maximum value is 8 MPa, but we expect the region of the vertical rod to be more critical.

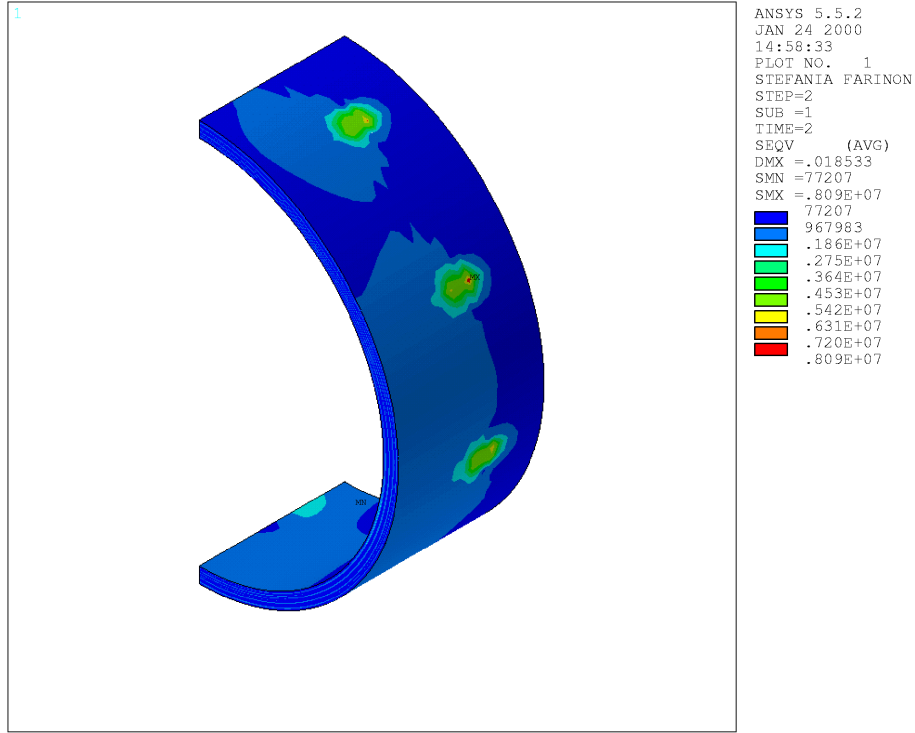

FIG. 4: Von Mises stress on the mandrel due to cool-down in the region of the longitudinal tie rods.

2.2.3 Solenoid energisation

Due to solenoid energisation, the longitudinal tie rods are stressed up to 258 MPa, which is again in good agreement with the results obtained by the hyper-static model. The stress distribution on the mandrel will be discussed in detail in §3.2.3.

3 EFFECT DUE TO RADIAL AND VERTICAL RODS

Fig. 5 schematizes the actual radial and vertical supporting system of the coil. The coil is supported by 4 vertical rods BB', 60 mm in diameter, and 8 radial rods AA' and CC', 35 mm in diameter. The length of each rod is 1380 mm; A, B, C are the positions of shoulders on coil and A', B', C' are the positions on vacuum tank. For $x > 0$ the x and y positions satisfy the following relationships:

$$\text{Position on coil: } \begin{cases} x_i = R \cos \Phi_i \\ y_i = R \sin \Phi_i \end{cases} \quad i = A, B, C \quad (1)$$

$$\text{Position on cryostat: } \begin{cases} x'_i = R \cos \Phi_i - \ell \sin \Phi_i \\ y'_i = R \sin \Phi_i + \ell \cos \Phi_i \end{cases} \quad i = B \quad (2)$$

(vertical rod)

$$\text{Position on cryostat: } \begin{cases} x'_i = R \cos \Phi_i + \ell \sin \Phi_i \\ y'_i = R \sin \Phi_i - \ell \cos \Phi_i \end{cases} \quad i = A, C \quad (3)$$

(radial rods)

where $R=3548$ mm, $\Phi_A=51^\circ$, $\Phi_B=9^\circ$, $\Phi_C=-69^\circ$.

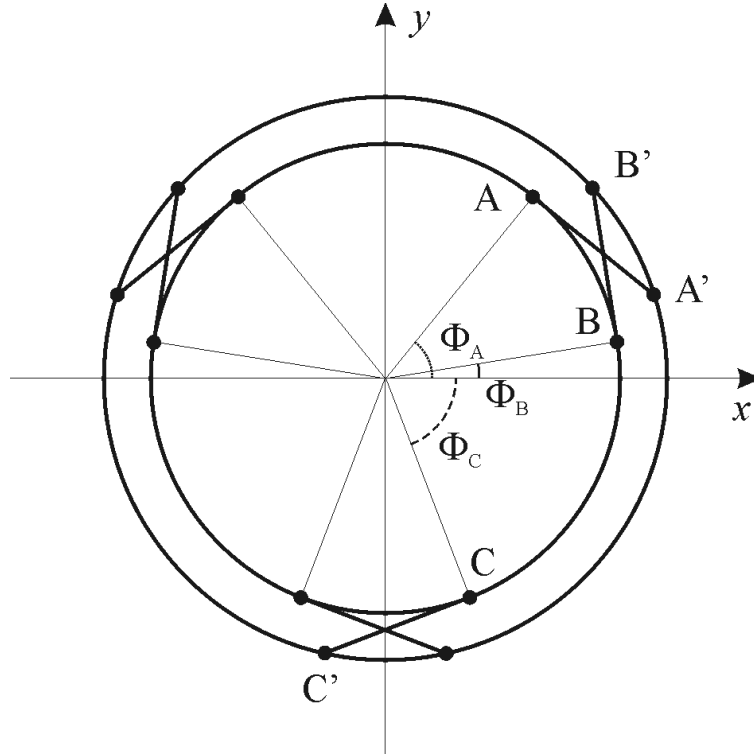

FIG. 5: Scheme of the radial supporting system.

3.1 Hyper-static analysis

Also in this case we start carrying out simple consideration not involving FE analysis.

3.1.1 Solenoid weight

In principle the weight of the coil ($P=225$ tons) would be taken by the four vertical rods, which are loaded to $\sigma = \frac{P}{4A_B \cos \Phi_1}$, where A_B is the vertical rod cross section (2827.4 mm^2). Each rod is then stressed to 197 MPa, and consequently we have a coil vertical misalignment due to the tie rods deformation $\Delta y = -\ell \cos \Phi_1 \frac{\sigma}{E}$, where E is the elastic modulus at room temperature (110 GPa) and $\ell=1380$ mm the tie rod length. The result is $\Delta y = -2.45$ mm. Obviously, this applies to a completely rigid body motion, since it does not take into account any coil deformation. Considering that, due to its own weight, the coil should be compressed in the axial direction, we expect from FE analysis a vertical displacement lower than -2.45 mm.

3.1.2 Cool down

To study the effect of cool-down to 4.2 K, we have to solve the following equation:

$$F_{Ay}(\Delta y) + F_{By}(\Delta y) + F_{Cy}(\Delta y) + P/4 = 0, \quad (4)$$

where $F_{Ay}(\Delta y)$, $F_{By}(\Delta y)$ and $F_{Cy}(\Delta y)$ are the projections on the y axis of the elastic forces due respectively to the tie rods A, B and C, P is the weight and Δy is the unknown displacement of the coil in the y direction.

Let us concentrate on the determination of $F_{By}(\Delta y)$. After cooling down to cryogenic temperature, the tie rod B will experience a force, along the $\overline{BB'}$ direction, expressed by:

$$\vec{F}_B = \bar{E}A_B \frac{\Delta \bar{\ell}}{\ell'}, \quad (5)$$

where $\bar{E}=125$ GPa is the averaged Young modulus between room temperature and cryogenic temperature, A_B is the cross section area of tie rod B, $\Delta \bar{\ell}$ is the unknown displacement in the $\overline{BB'}$ direction, and $\ell' = \ell(1 - 3.1 \cdot 10^{-6} \cdot 296) = \ell(1 - n)$ is the contracted length at 4.2 K. Projecting this force on the y axis we find

$$F_{By} = \bar{E}A_B \frac{|\Delta \bar{\ell}|}{\ell'} \cos \beta, \quad \text{where } \cos \beta = \frac{y_{B'} - y_B}{\overline{BB'}}. \quad (6)$$

Introducing now the contracted radius $R' = R(1 - 4.3 \cdot 10^{-3}) = R(1 - m)$, and the contracted z coordinate $z'_B = z_B(1 - 4.3 \cdot 10^{-3}) = z_B(1 - m)$, $F_{By}(\Delta y)$ is found to be

$$F_{By} = \bar{E}A_B \frac{\overline{BB'} - \ell'}{\ell'} \cdot \frac{\ell \cos \Phi_B + mR \sin \Phi_B - \Delta y}{\overline{BB'}}, \quad (7)$$

where:

$$|\Delta \bar{\ell}| = \overline{BB'} - \ell' = \sqrt{(mR)^2 + \ell^2 + \Delta y^2 - 2\Delta y(\ell \cos \Phi_B + mR \sin \Phi_B) + (mz_B)^2} - \ell' \quad (8)$$

Since $\Delta y \approx 0$ with respect to the length $\overline{BB'}$, we can expand expression (8) in Taylor series stopping at the first order:

$$\overline{BB'} \approx \sqrt{(mR)^2 + \ell^2 + (mz_B)^2} - \frac{\ell \cos \Phi_B + mR \sin \Phi_B}{\sqrt{(mR)^2 + \ell^2 + (mz_B)^2}} \Delta y. \quad (9)$$

Finally, setting $L_B = \sqrt{(mR)^2 + \ell^2 + (mz_B)^2}$ and $b = \ell \cos \Phi_B + mR \sin \Phi_B$, the expression for $F_{By}(\Delta y)$ will be:

$$F_{By}(\Delta y) = \bar{E}A_B \left(\frac{L_B^2 - b\Delta y}{\ell'} - L_B \right) \cdot \frac{b - \Delta y}{L_B^2 - b\Delta y}. \quad (10)$$

Following the same procedure, it is possible to find

$$F_{Ay}(\Delta y) = -\bar{E}A_A \left(\frac{L_A^2 + a\Delta y}{\ell'} - L_A \right) \cdot \frac{a + \Delta y}{L_A^2 + a\Delta y}, \quad (11)$$

$$F_{Cy}(\Delta y) = -\bar{E}A_C \left(\frac{L_C^2 - c\Delta y}{\ell'} + L_C \right) \cdot \frac{c + \Delta y}{L_C^2 + c\Delta y}, \quad (12)$$

with L_A , L_C , a and c defined analogously to L_B and b.

It is now possible to solve Eq. (4), finding $\Delta y = -1.05$ mm. This axial displacement leads to

a maximum stress on the vertical tie rod of 250 MPa, and on the radial rods A and C of respectively 78 MPa and 106 MPa.

3.1.3 Solenoid energisation

The solenoid energisation is a completely axi-symmetric load, so we do not expect to have a further axial displacement of the winding. From the point of view of the radial tie rods, the energisation leads to a radial pressure of 64 atm, corresponding to a radial strain $1.5 \cdot 10^{-3}$, and to a longitudinal compression of 4.3%. Both the contributions leads to a negligible variation of the stress level on the radial and vertical tie rods, with respect to the values achieved during cool-down.

3.2 Finite element analysis

We have used the same model described in §2.2.1.

3.2.1 Solenoid weight

Fig. 6 shows the vertical displacements of the winding; the value at the center mass is -2.25 mm, in good agreement with -2.45 mm calculated above with simple considerations and not considering the solenoid deformations. Fig. 7 shows the excellent agreement of the axial stress in the vertical tie rod between the simple and FE model.

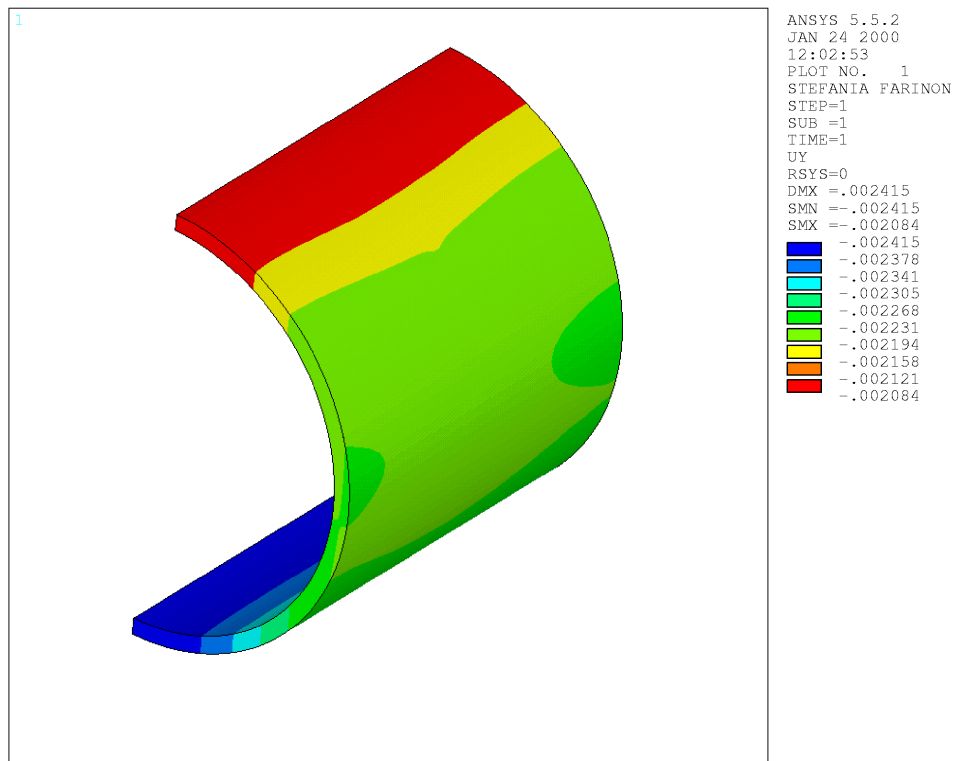

FIG. 6: Vertical displacements due to gravity.

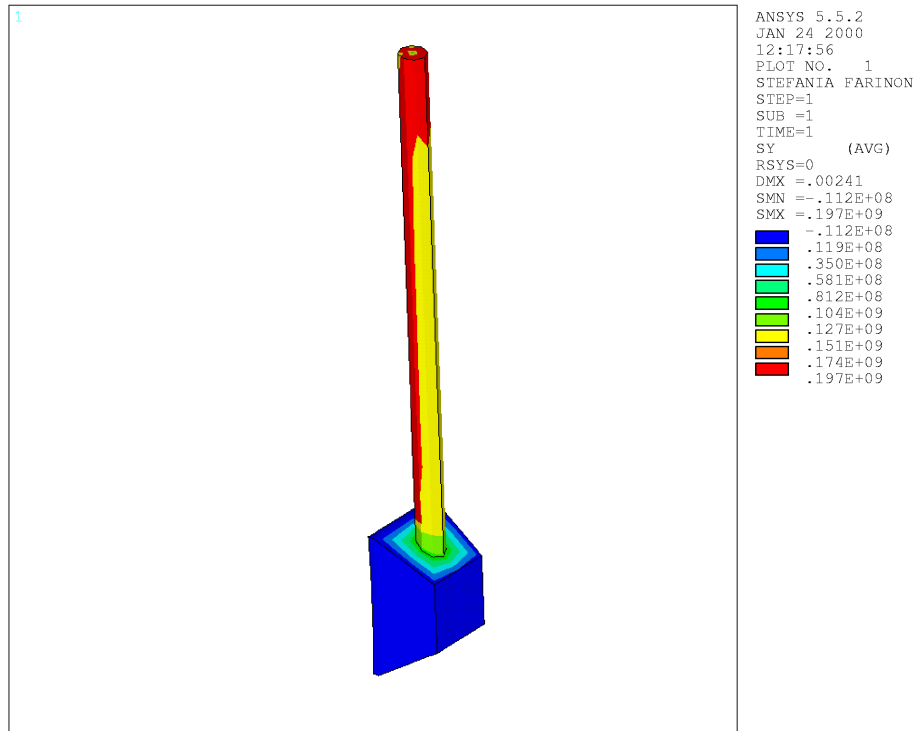

FIG. 7: Axial stress in the vertical tie rod due to gravity.

3.2.2 Cool down

As for the axial rods a thermal analysis has been carried out giving the following results:

- The effect on the cylinder is to add at maximum 11.8 MPa Von Mises stress (see Fig. 8).
- The center of gravity of the coil is now -1.04 mm, to be compared with -1.05 mm coming from the simple model.
- The tie rods are stressed in tension (250 MPa vertical rods, 100 MPa and 120 MPa respectively radial rod A and C).

All results are in good agreement with the ones coming from the simple considerations.

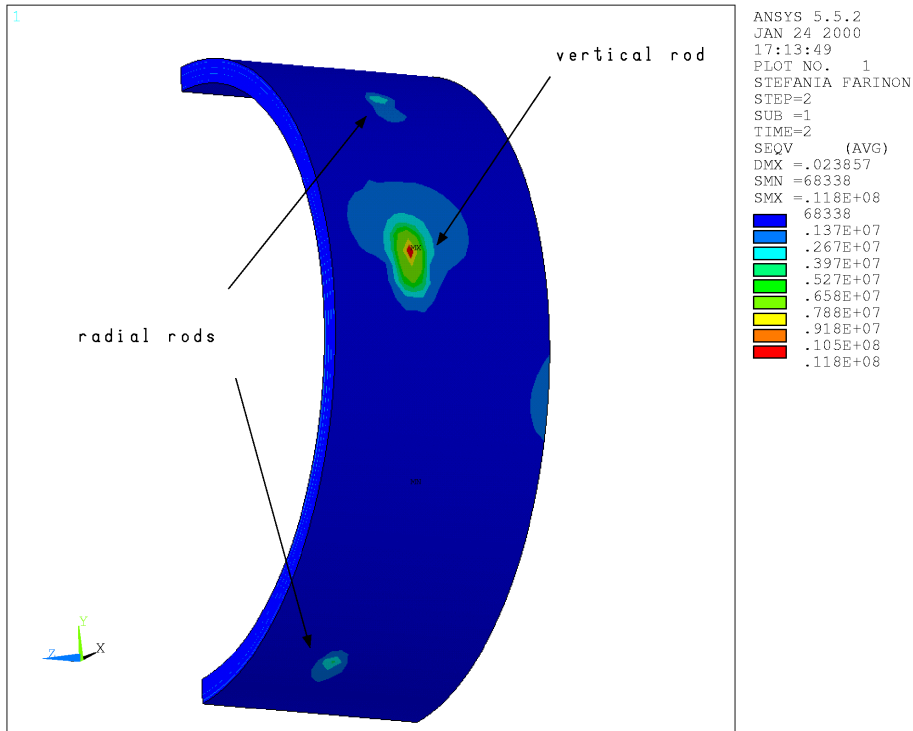

FIG. 8: Von Mises stress on the cylinder due to cool down.

3.2.3 Solenoid energisation

Energisation, as expected, does not substantially modify the stress level on the tie rods (and consequently on the shoulders). Instead it causes the most significant stress on the cylinder. Fig. 9 shows the stress distribution on the cylinder after energisation. It is worth of mention the fact that the perturbation due to tie-rods attachment is quite negligible. On the basis of this information, it follows immediately that there is no special recommendation for welding the shoulders to mandrels; i.e. the welding can be made also very close to the shoulder.

A second important drawback is the fact that there is a substantial axisymmetric distribution of stress on the cylinder. Then, we can consider as final results the ones coming from the 2D computation, which were done with a more realistic model, comprising all the single turns, with their Rutherford cables and insulation. In Fig. 10 the results of the 2D axisymmetric model are shown.⁴⁾

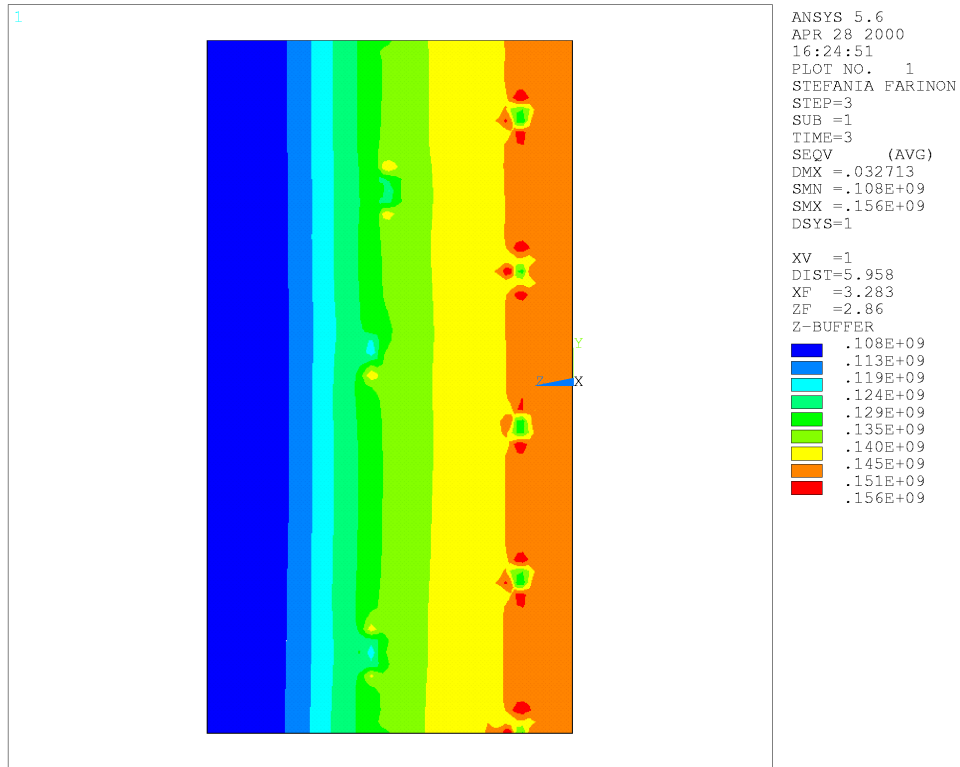

FIG. 9: Von Mises stress on cylinder after energisation. For a better displaying of the stress distribution, the cylinder has been cut and laid on a plane.

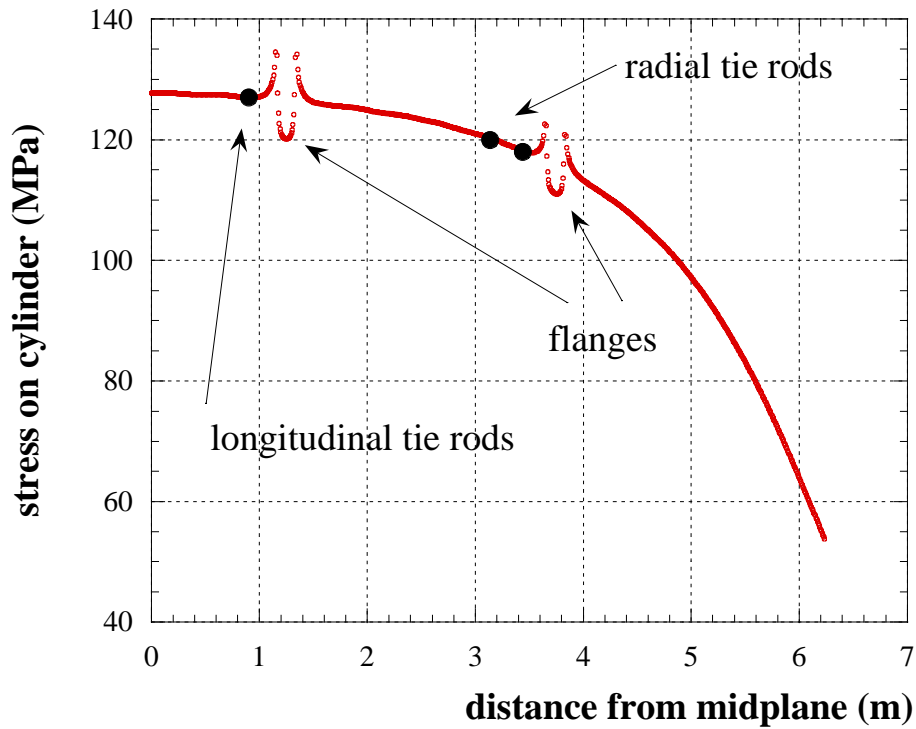

FIG. 10: Stress on the cylinder as function of the distance from the magnet midplane coming from 2D axisymmetric calculation.

4 SHOULDER STRESS DISTRIBUTION

We mentioned that the 3D FE model is a simplified one, made to understand the overall behavior of CMS magnet under the loads it should sustain. Regarding the shoulders, there is no way to model the screws that link the tie rods to their shoulders. As a result, when looking just at the stress on the shoulders, this approach causes a lack of information, since in our model the force field is not correctly transferred from tie rods to shoulders. In order to overcome this problem we have used a special model for the shoulders only. Since the stress in the shoulder is determined by the stress in the tie rods, we have analyzed how the stress on shoulders depends on the force transmitted through the tie rods. So far, we have modeled a shoulder connected to the vertical tie-rod (the most critical one) as close as possible to the real one (Fig. 11). We have considered fixed the base of the plate containing the shoulder and then we have applied a force along the axis of the shoulder hole and uniformly on the internal surface of the hole itself. The force strength was of 250 MPa equivalent to the one due to weight plus cool-down. Fig. 12 shows the stress distribution on the shoulder: the peak stress is 140 MPa, i.e. not really higher than the stress on cylinder due to cool-down plus energisation (though the two stresses have no relation). This information can be used to scale the stress on shoulders with stress on tie rods.

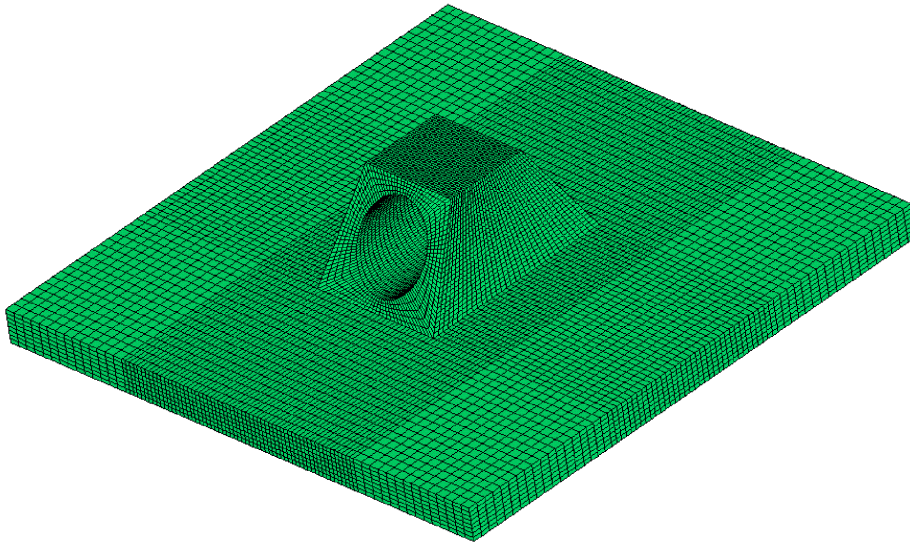

FIG. 11: Simplified model to analyze the stress distribution on shoulders.

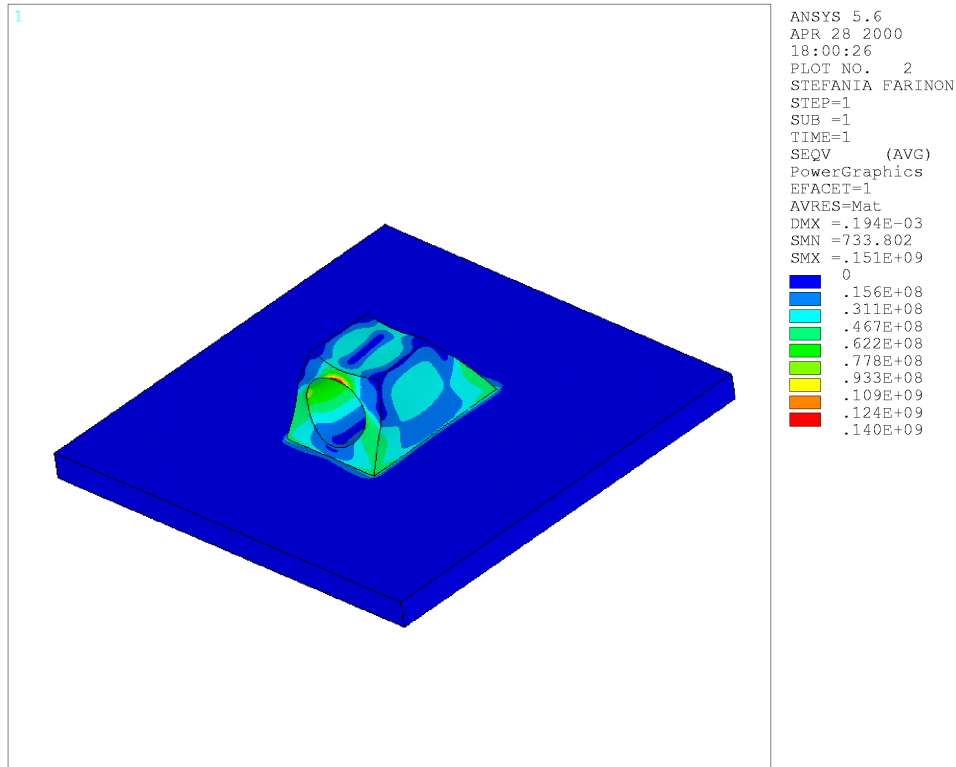

FIG. 12: Resulting stress distribution on shoulders;
 the deformations are 200 times amplified.

5 IMPACT ON STRESS DUE TO CRYOSTAT DEFORMATION

The previous computations assume that the positions of the warm ends of the tie rods are fixed, with no allowed displacements. Consequently, they could be pessimistic due to local deformations of cryostat limiting tie-rods strain.

Obviously, this has no effect on the stress coming from the weight, so that the results shown for this load do not need any more correction. On the other hand, it could be of some importance during the cooling down, when any deformation of the cryostat leads to a lowering of the stress on tie rods and cylinder.

To know how much this effect can influence our previous calculations, an *ad hoc* simplified FE model, shown in Fig. 13, has been used: the winding and the cryostat are meshed with shell elements, whilst beam elements simulate the tie rods. We have analyzed two different cases: a) cryostat of infinite rigidity, which behaves as the warm ends of the tie rods would be completely bonded, b) cryostat with proper rigidity, to evaluate its deformations. The comparison of results allows to determine the effect of cryostat deformations.

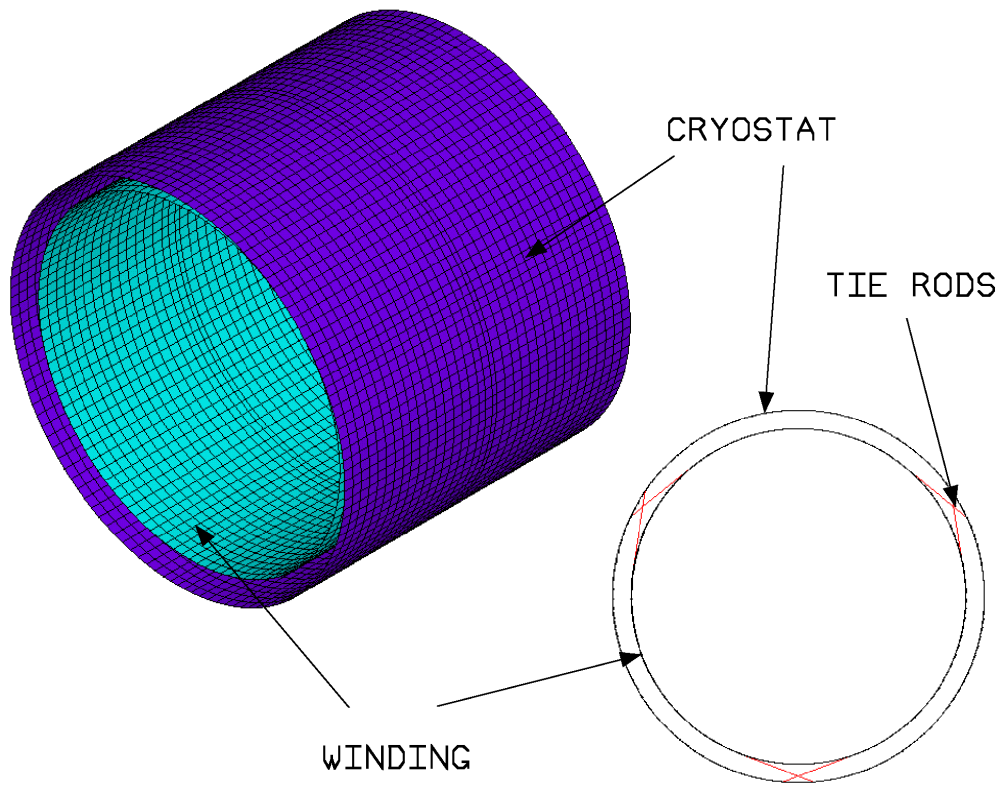

FIG. 13: Simplified FE model containing the winding, the cryostat and the tie rods.

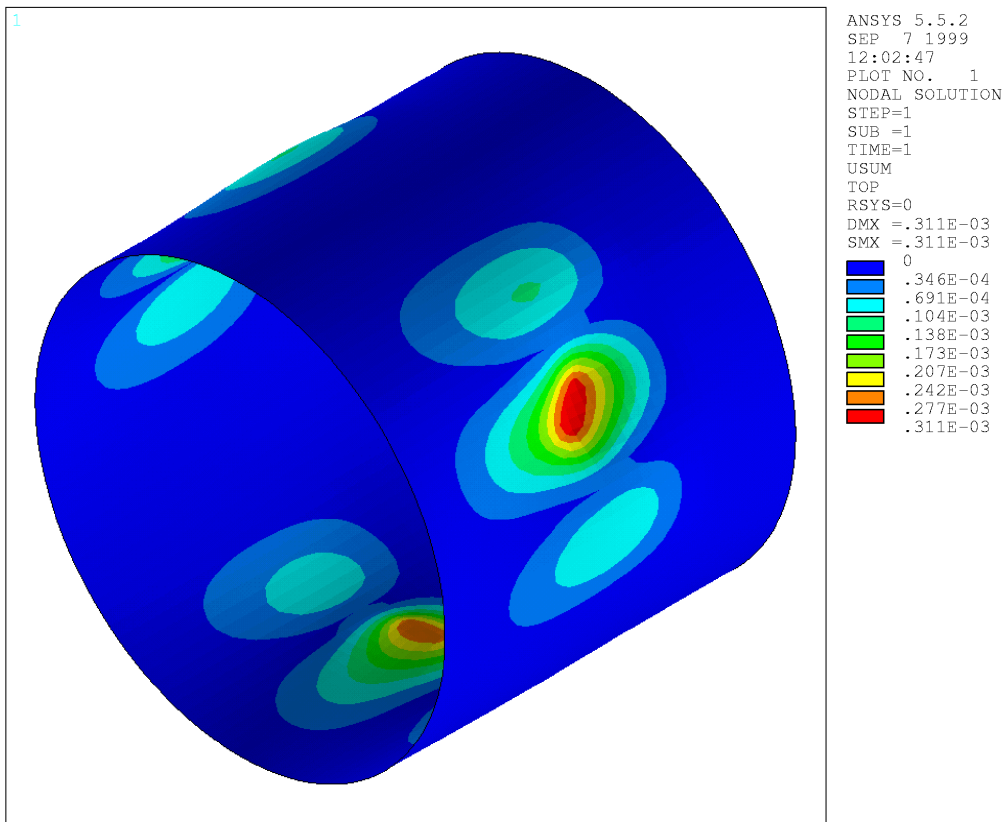

FIG. 14: Cryostat deformations due to cool-down.

The results are that the stresses on cylinder and tie rods are lowered at maximum up to 10%. This is confirmed by the deformations of the cryostat, which are 0.3 mm maximum and 0.1 mm along the direction of the tie rods. So, if the total contraction of the tie rods is 1.27 mm, as shown in §3.1.2, a reduction of about 10% leads to 0.1 mm kept by the cryostat. The conclusion is that the results shown in previous sections and obtained not considering any deformation of the cryostat are pessimistic within 10%.

6 CONCLUSIONS

As conclusion of this report Table 2 shows the peak Von Mises stress in the components related to the support system in the different situations:

TAB. 2: Von Mises stress in supporting system.

	Longitudinal rods [MPa]	Vertical rods [MPa]	Radial rods [MPa]	Cylinder [MPa]	Shoulder (vertical rod) [MPa]
Weight	0	197	0	8	110
Cool-down	235	250	100-120	12	140
Energisation	258	250	100-120	130 (2D)	140

REFERENCES

- (1) Computer code ANSYS[®], Revision 5.6, Swanson Analysis Systems, Inc., 2000.
- (2) B.Curé, D.Campi, A.Desirelli, S.Farinon, A.Hervé, H.Gerwig, J.P.Grillet, F.Kircher, V.Klioukhine, B.Levesy, R.Loveless, R.Smith, *MT-16*, September 26 October 2 1999, Jacksonville FL.
- (3) C.Pes, DSM/DAPNIA/STCM Technical Report 5C 2100T-1000 035 DA, August 25, 1999.
- (4) S.Farinon, P.Fabbricatore, INFN/TC-98/10, 3 Marzo 1998.