



EUROPEAN ORGANIZATION FOR NUCLEAR RESEARCH  
ORGANISATION EUROPÉENNE POUR LA RECHERCHE NUCLÉAIRE

**CERN - ST Division**

CERN-ST-2000-020

February, 2000

## **THERMAL ANALYSIS OF THE ALICE DETECTOR FOR THE LHC**

G. Peón

### **Abstract**

In the same fashion as for the other LHC detectors, ALICE requires stringent conditions of temperature stability in time and space and adequate absolute values, which vary for each sub-detector. For the design of the cooling and ventilation systems inside the detector, three different studies have been undertaken. The first investigates the temperature distribution and hot spots in the volume enclosed by the L3 magnet for different ventilation configurations. The second study deals with the cooling of the muon chambers inside the dipole magnet and, in particular, analyses the possibility of air-cooling pairs of muon chambers to remove the residual heat flux by forced convection. The third study examines the contribution of the surroundings to the temperature gradients in the drift gas (Ne/CO<sub>2</sub>) of the TPC sub-detector. The different computational results will be shown and some design proposals presented.

Presented at the 3<sup>rd</sup> ST Workshop  
Chamonix, France, January 25 - 28, 2000

## 1 INTRODUCTION

The ALICE detector is one of the four particle detectors that will use the LHC accelerator facility to explore the heart of matter, in particular; ALICE is a dedicated heavy-ion experiment to study nuclear collisions. To do so, the ALICE detector consists of a variety of tracing devices called sub-detectors enclosed in a volume limited by the existing L3 magnet: a weak-field, large solenoid magnet. The sub-detectors are placed in cylindrical layers around the beam line.

The innermost is the Inner Tracker System (ITS) which, in turn, consists of three pairs of silicon detector layers. The outer pair is composed of strip detectors that dissipate 3 kW and the inner is made up of pixel detectors that dissipate 500 W. Both pairs of layers, together with the front-end electronics (2 kW), are water-cooled. On the other hand, the drift-detector layers require temperature stability of 0.1°C and, for this purpose, use an evaporative cooling system. The operating temperature for the sub-detector is 20°C.

The Time Projection Chamber (TPC) surrounds the ITS. It consists of three cylindrical vessels: CO<sub>2</sub> flows in the inner and outer vessels and a mixture of 10% CO<sub>2</sub> and 90% Ne in the central one. Front-end electronics situated at the end flanges dissipate about 20 kW and are water-cooled.

The Transition Radiation Detector for electron identification (TRD) envelops the TPC and dissipates about 100 kW

The basic element of the PHOTon Spectrometer (PHOS) sub-detector is a PbWO<sub>4</sub> crystal. The PHOS sub-detector consists of 36 608 crystals and their electronics grouped in four thermal-insulated cradles positioned on the bottom of the ALICE set-up. The cradles are kept at -25° with 0.1°C of accuracy by binary ice. A pin diode dissipating 2 μW per channel is the only heat-producing electronics in close contact with a crystal.

The High Momentum Particle IDentification (HMPID) is made up of eight boxes placed on an imaginary sphere centred at the ALICE intersection point. A so-called radiator and a photodetector are the active parts of HMPID. Electronics in each box dissipate 150 W.

The L3 magnet is water-cooled and dissipates 4 MW. A water-cooled thermal screen placed around the internal surface of the magnet prevents heat leaks to the enclosed internal sub-detectors.

The muon tracking chambers, TC1 to TC10 (numbered from the intersection point), are discs perpendicular to the beam axis. There are three groups: the first between the front absorber and the dipole has four discs, the second inside the dipole magnet has two discs, and the third between the dipole and the muon filter has four (see Fig. 1).

## 2 THE VENTILATION SYSTEM OF L3

The volume of the L3 magnet has a dedicated ventilation system, the purpose being to remove residual heat leaks not removed by the main cooling system of each sub-detector, and to limit the build-up of flammable gases in the event of small leaks. At present, the nominal air flow is 6000 m<sup>3</sup>/h at a temperature of 18°C with a dew point of 10°C.

With the use of the Computational Fluid Dynamics (CFD) code Star-CD, different ventilation strategies have been analysed. The volume of air inside L3 has been modelled using the meshing capabilities of ANSYS (Fig. 1). The residual heat loads dissipated for each sub-detector to the air have been assumed to be 10% of the total heat generated and the temperature of the thermal screen constant and equal to 293 K. In the model, the air is supplied into the volume by means of four tubes parallel to the beam axis and close to the magnet thermal screen. The tubes are perforated longitudinally in such a way as to force the air towards the sub-detectors. The air exits the L3 enclosure through the hole of the door opposite the front absorber. The maximum temperature difference in the detector must be 5 K to ensure adequate running conditions.

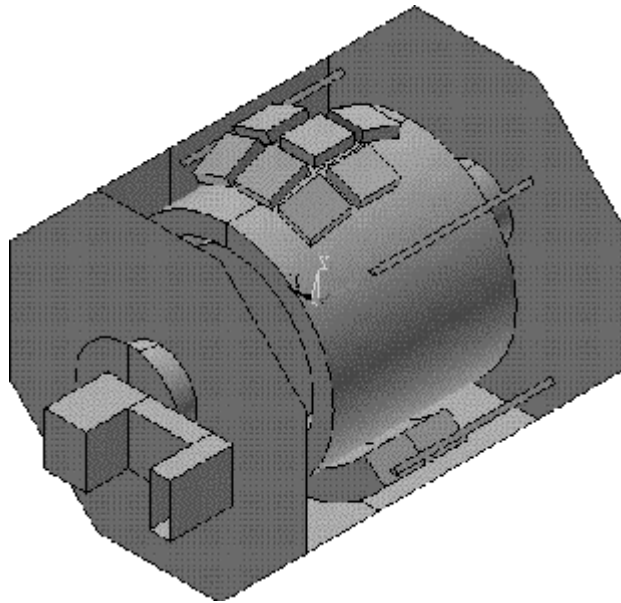
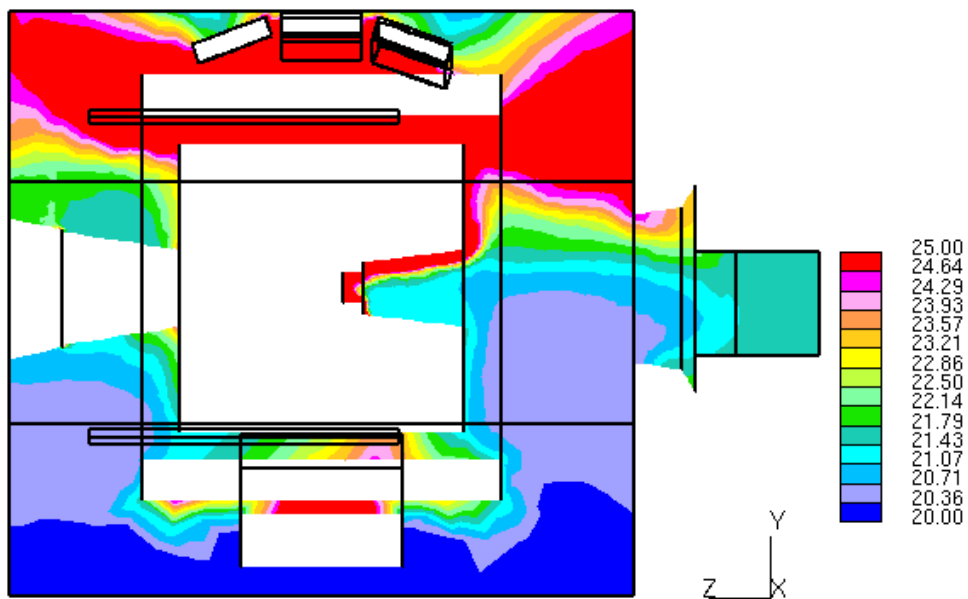

**Figure 1:** Model of the ALICE detector.

Four different scenarios have been studied: in the first, the ventilation is stopped and the air is only cooled by the L3 thermal screen. In the second case, 10 000 m<sup>3</sup>/h enter the volume at a temperature of 20°C. The third case assumes a temperature of the supplied air of 15°C and the fourth, an air flow double that of the second case.

Results of the second case are presented in Fig. 2. The upper temperature limit was set to 25°C to highlight in red the zones with a temperature higher than the adequate maximum. The analysis of the four cases studied shows that the temperature in the volume goes beyond 25°C at the following points:

- between the PHOS and the PID,
- at the space surrounded by the TPC close to the ITS,
- and at the upper part of the detector.



**Figure 2:** Temperature map of the air at the central plane for a supply of 10 000 m<sup>3</sup>/h of air at 20°C.

The comparison among the cases showed that increasing the air flow or lowering the temperature of the supplied air (which has to be kept above the dew point temperature to prevent condensation) hardly contributes to the decrease in temperature at the hot spots. It was concluded that ventilation is insufficient to even out the temperature in the detector and therefore, an additional effort should be made to remove a higher power percentage close to the heat source by other means than ventilation.

### 3 THERMAL ANALYSIS OF THE AIR ENCLOSED BY THE ALICE DIPOLE

A calculation has been carried out to predict the temperature of the air surrounded by the dipole magnet of the ALICE detector.

The air is assumed to be enclosed in a volume formed by the front absorber, the cone between muon chambers TC1 and TC4, the dipole magnet, the dipole thermal screen and the muon chamber TC8. Muon chambers TC1 to TC8 and the small-angle absorber have also been modelled (see Fig. 3).

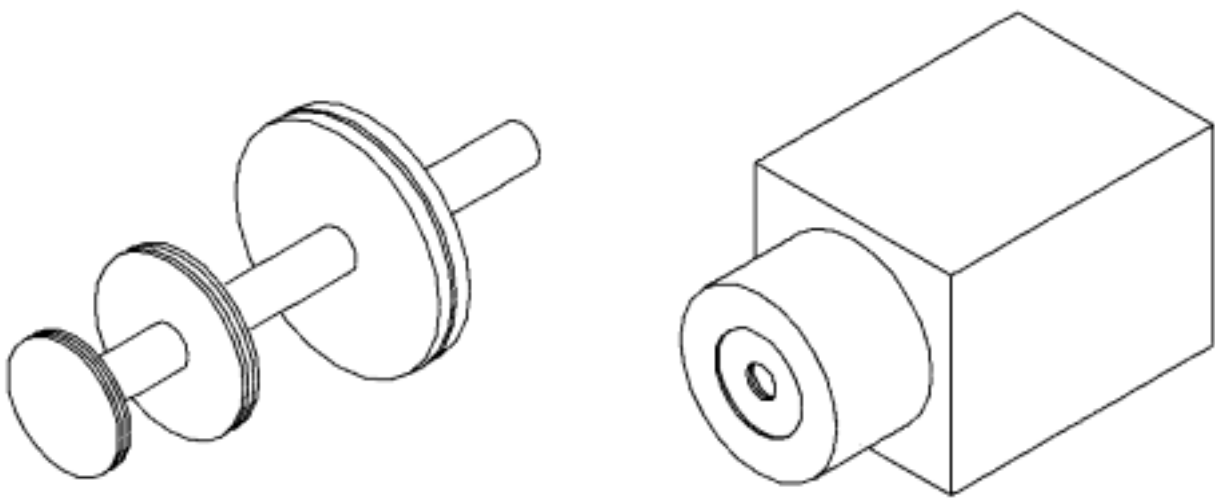

**Figure 3:** Model of the muon chambers and small-angle absorber (left) and its enclosure (right).

The thermal equilibrium is established between the muon chambers' flat walls as heat sources and the dipole thermal screen and external part of the cone as heat sinks. The thermal loads of the muon chambers to the air are assumed to be  $200 \text{ W/m}^2$  on all the dissipating surfaces. The thermal screen and outer temperature of the cone surface are set to  $20^\circ\text{C}$ . Radiation was neglected on the basis of low-emissivity surfaces and to solve a worst-case scenario.

The calculated bulk temperature at the interior of the volume was about  $100^\circ\text{C}$  and, at some points between two dissipating planes, the temperature rose to about  $140^\circ\text{C}$  (see Fig. 4).

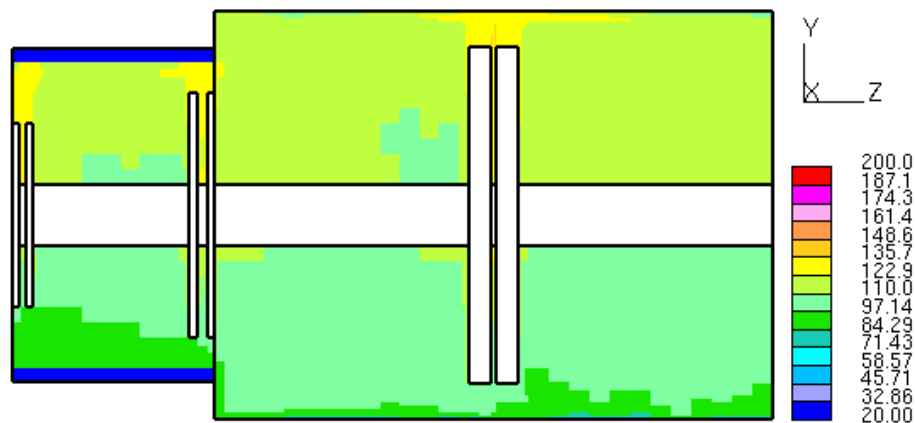

**Figure 4:** Temperature map of the air in the enclosure housing TC1 to TC8.

Although the exact numbers cannot be considered realistic because of the assumptions made, they reveal temperatures far too high to be appropriate for the operation of the sub-detector. In this respect, steps to deal with the problem have been taken and a study is under way to assess the possibility of air-cooling pairs of muon chambers by forced flow.

### 3.1 Forced air-cooling of muon tracking chambers

The purpose of this calculation is to predict the temperature of the air inside an enclosure that would house two muon chambers. The pairs of muon chambers would be shut in and air at 20°C would be blown into the enclosure from the bottom and extracted from the top.

The muon chambers are represented as circular crowns of internal diameter 600 mm and external 2400 mm. From diameter 600 mm to 1200 mm, they dissipate 400 W/m<sup>2</sup> and from 1200 mm to 2400 mm, 200 W/m<sup>2</sup>. The enclosure is cylindrical of diameter 3000 mm and length 450 mm (see Fig. 5). The thermal equilibrium is reached between the muon chambers as heat sources and the increase of temperature of the flowing air.

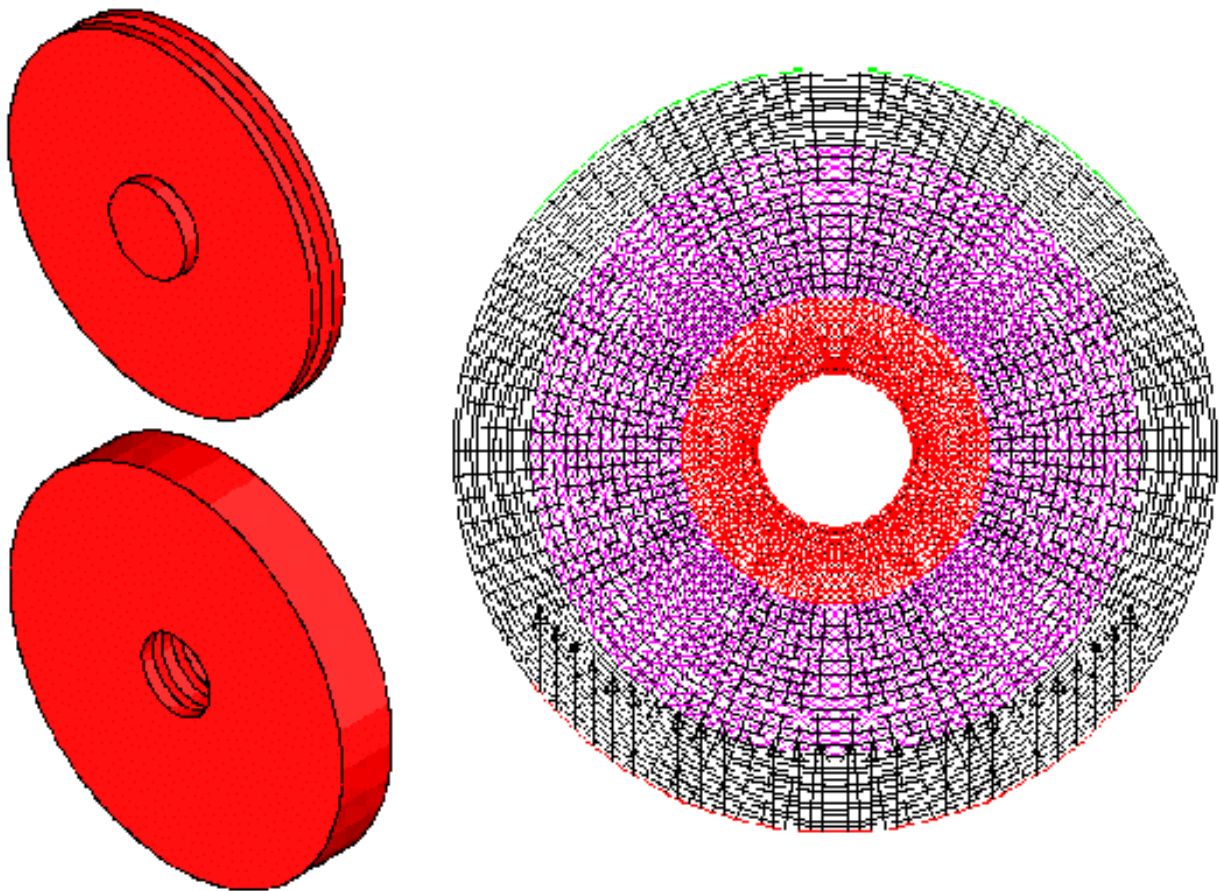

**Figure 5:** Model of the muon tracking chambers and enclosure (right) and boundary conditions (left).

Six different cases have been analysed. In cases 1 and 2, air is blown in vertically along the whole length of the enclosure at an angle of 106° such as to point to all the heat-dissipating surface. In cases 3 to 5, the inlet is restricted in length (only between both muon chambers) and in angle (only pointing to the 400 W/m<sup>2</sup> surface).

The main parameters and the results are summarized in Table 1.

**Table 1** Studied options for the cooling of muon chambers

	Inlet area (m <sup>2</sup> )	Outlet area (m <sup>2</sup> )	Inlet air vol. (m <sup>3</sup> /h)	Inlet speed (m/s)	T. OUT (K)	T. MAX (K)
Case 1: wide inlet 1m/s	1.25	1.25	4500	1	22.7	42
Case 2: wide inlet 0.5m/s	1.25	1.25	2300	0.5	25.5	48
Case 3: narrow inlet	0.12	0.12	600	1.35	40.9	61
Case 4: narrow inlet + baffles ang. 45° and 135°	0.12	0.12	600	1.35	40.9	61
Case 5: narrow inlet + baffles with holes	0.12	0.12	600	1.35	40.9	59
Case 6: 3 inlets	0.24	0.12	600	0.67	40.9	63

The results show that the maximum temperature (T. MAX) in the enclosure is, in all cases, about 20 K above the average outlet temperature (T. OUT), and just a small improvement is observed in case 5 (see Fig. 6) with respect to cases 3, 4 and 6. Case 1 produces adequate results but the air flow is in principle unfeasible.

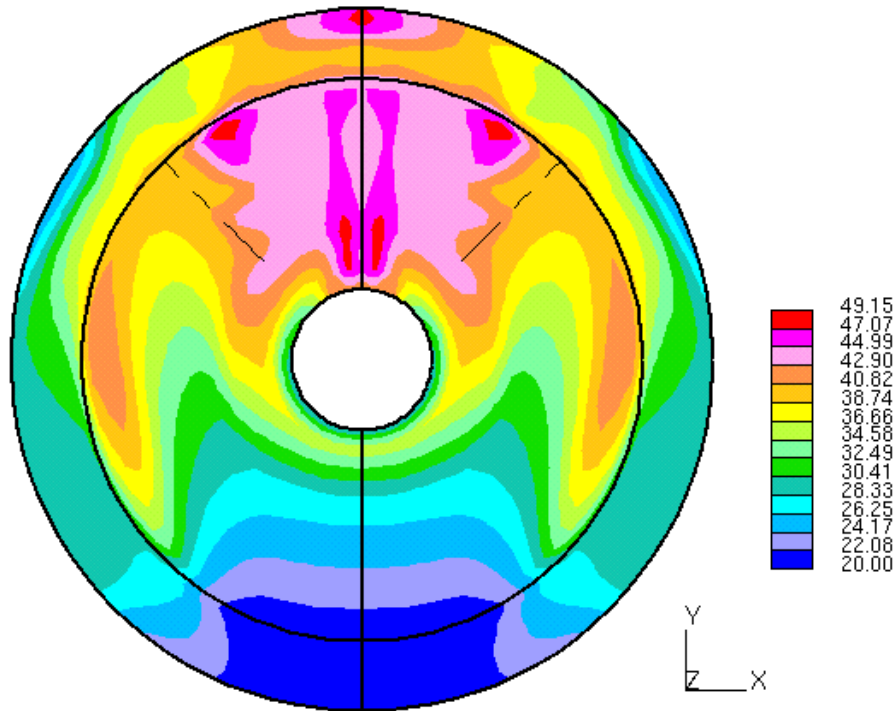
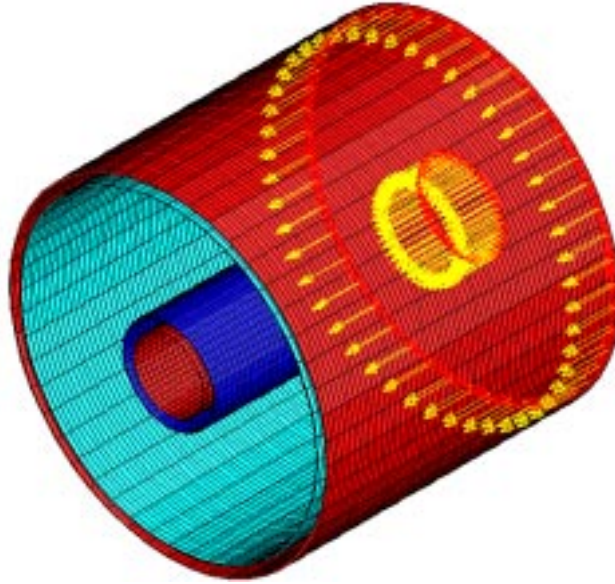

**Figure 6:** Temperature map (°C) of the air between the two muon tracking chambers (Case 5).

#### 4 THERMAL INFLUENCE OF THE TRD ON THE TPC

A small gap of 10 mm separates the TRD and the TPC. A small temperature difference between the TRD surface and the inlet temperature of CO<sub>2</sub> and Ne/CO<sub>2</sub> may provoke a considerable temperature difference between two points of the Ne/CO<sub>2</sub> mixture inside the sub-detector.

The goal of the analysis is to quantify the thermal disturbance of the TRD on the TPC. To do so, a Star-CD model was built. It includes a simplified geometry of the TPC sub-detector, which consists of four cylindrical shells that are thermal insulators (see Fig. 7).



**Figure 7:** Model of the TPC shells and inlet of CO<sub>2</sub>.

The model also incorporates the TRD surface close to the TPC and the air between both sub-detectors. The assumed temperature of the TRD is 20°C and that of the gases at inlet is 18°C. The assumed mass flow rate for the Ne/CO<sub>2</sub> mixture and for the CO<sub>2</sub> is 10 m<sup>3</sup>/h.

The results show a maximum temperature difference of 1°C within the Ne/CO<sub>2</sub> mixture (see Fig. 8). This value proves to be insufficient for the good performance of the sub-detector. A proposed solution is an actively cooled thermal screen between both sub-detectors to thermally uncouple them.

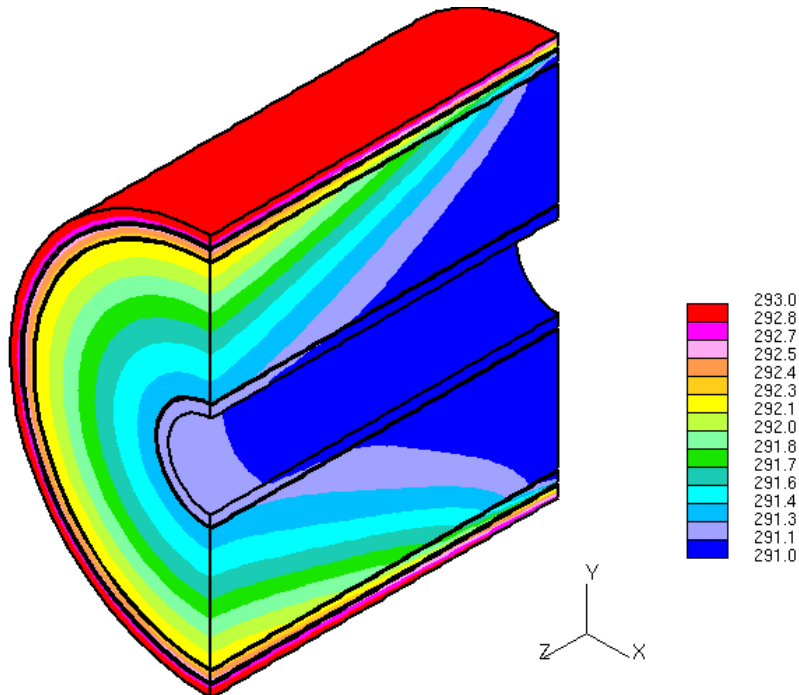

**Figure 8:** Temperature map (K) of the gases flowing in the TPC.

## 5 CONCLUSIONS

In spite of the work performed in the past for the cooling of the ALICE detector, calculations indicate that an additional effort is required to reduce hot-spot temperatures in the air enclosed by the L3 magnet. The thermal analysis of the air in the dipole magnet of ALICE proved that natural convection is insufficient for the cooling of the muon tracking chambers.

Cooling of enclosed pairs of muon tracking chambers by a flow of air has been considered and suitable results can be found for an air flow of 4500 m<sup>3</sup>/h. Finally, the influence of the TRD on the TPC was quantified and proved to be important. The use of a thermal shield between both sub-detectors is proposed.

## **REFERENCES**

- [1] ALICE Collaboration, 'ALICE technical proposal for a large ion collider experiment at the CERN LHC', CERN/LHCC/95-71, LHCC/P3, 15 December 1995.
- [2] L. Olsson, 'Thermal analysis of the inner part of the ALICE detector', Degree project, Royal Institute of Technology, Stockholm, Sweden.