

OPTICAL LINK DEVELOPMENTS FOR THE CMS RPC

K. Banzuzi (email: Kukka.Banzuzi@helsinki.fi), B. McCartney and E. Pietarinen, Helsinki Institute of Physics

T. Czyzew, M. Hojda, P. Foryt, T. Nakielski, K. Pozniak and R. Romaniuk, Warsaw University of Technology

M. Kudla and G. Wrochna, Warsaw University

Abstract

The rather general data link component testing and evaluation work done at the Helsinki Institute of Physics has become more and more focused on providing a working solution for the CMS RPC fibre optic trigger and data links. A new test board, LINX, has been designed to fill the specific needs of RPC links prototyping, including implementation of a data compression scheme. In this paper the LINX board is described in some detail, and a link solution based on commercial components available at the moment is proposed. Gamma and proton irradiation test results for some of these components are also presented.

1. INTRODUCTION

The CMS RPC muon detector system has almost 200,000 channels, but a very low occupancy. Significant savings on the number of high speed data links needed are possible using data compression and multiplexing.

As illustrated below in Fig. 1, the readout system is

divided into the following components: Frontend Readout Board (FEB), which performs the digitisation of the data, Link Board (LB) containing synchronisation and data compression functions and the optical link. In the control room data from one link has to be split to several destinations to be forwarded to the Level-1 trigger by a Trigger Board (TB) or to the DAQ by a readout board (RB). At this end, too, the design will be modular, consisting of a separate link boards (TLB and RLB) with the decompressor and demultiplexer circuit DEMUX and the dedicated processor boards TB and RB.

The chambers will be served with different numbers of links according to their occupancy. Up to three chambers are connected to one link in the barrel, whereas in the endcap some relatively high occupancy chambers have two links per chamber. The first plan was to use one compressor circuit per chamber, but now it seems it may be possible to combine the data from up to three chambers in one LMUX, meaning that we would only need one kind of link board. This would add another multiplexing stage between the FEBs and the LBs, or alternatively we would have to accept a very

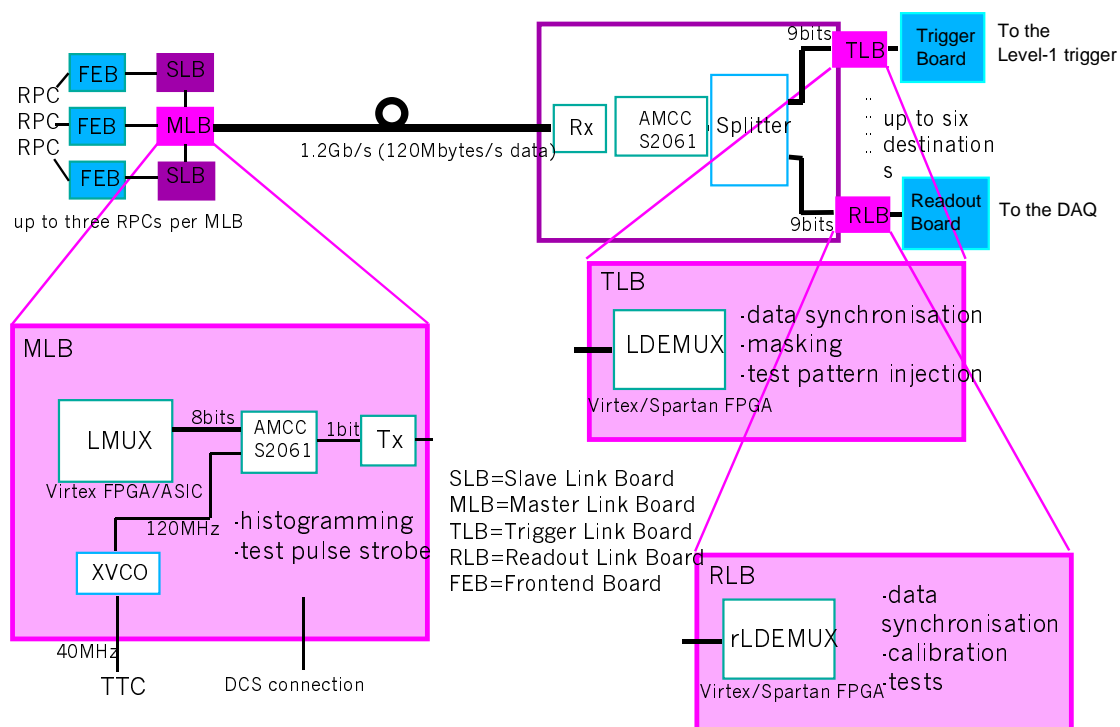

Fig. 1. Block diagram of the CMS RPC optical links

high pin count for the LMUX (3×96 inputs).

Presently it is envisaged to mount the link boards on two different locations on the muon chambers: the first four layers will be served with LBs in the space between muon stations MB/x/2 and MB/x/3, and the two outer layers with LBs on top of MB/x/4. Short LVDS links are needed to realise the connection between the frontend board and the link board. The synchronisation unit has only recently been moved away from the FEB to the LB, preliminary tests show the jitter levels introduced by this connection to be acceptable [1]. A detailed configuration for the endcap has not been proposed yet.

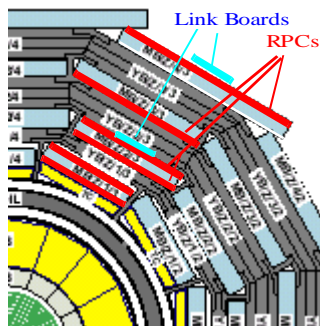

Fig.2. The link boards will be mounted on the detector in two different locations for each sector

2. CURRENT DESIGN BASELINE FOR THE RPC LINKS

2.1 Data Compression Scheme

The data compression scheme to be used is described in [2], only a short summary is presented here. The RPC chamber consisting of 96 strips is divided into 12 or 8 strip partitions. Only the non-empty partitions are sent, together with a partition number and a delay value. Two additional bits are added at the multiplexing stage of LMUX to denote the chamber number if data from more than one chamber are sent through one link. Flag bits are set if there is a cluster in between two partitions or if the data transfer is aborted because the maximum delay value has been reached. Very reliable operation is reached with a 24-bit data word, which would also leave one extra bit for error coding purposes, for example. With a partition size of 12, it would be possible to send the full raw data from the chamber in eight bunch crossings. The maximum delay value could then be set to around four bunch crossings (bx) for normal operation.

2.2 Components Chosen

The most suitable components available at the moment for our application are Gigabit Ethernet based serialiser/deserialiser chips which include data encoding for DC balance and which can be run at a variable bit rate, such as the AMCC S2061. In particular, we need to

operate at a multiple of the LHC bunch crossing rate 40.08 MHz, and we plan to use a PLL component to multiply this by three. The bit rate of the link would then be 1.2 Gbit/s, or 120 Mbyte/s of data.

Commercial transceivers based on VCSELs and PIN diodes will be used for the electric-optic conversion and vice versa. They work with multimode fibre, and are relatively inexpensive even though they are bidirectional and thus include extra components not needed.

Two alternatives are being investigated for the splitter: Channel Link and regular LVDS line drivers/receivers at 120 MHz. The latter would mean that more cables are needed, but the overall solution would be more elegant as we would not have to include yet another multiplexing stage.

In case the commercial components we plan to use do not prove to be radiation tolerant enough, the submicron link being developed at CERN [3] would directly fit into our design. The CMS ECAL G-link [4], on the other hand, only allows a 16-bit word to be sent during a bx. A more efficient and more complicated data compression scheme would be needed to cope with this slower speed, as with the current scheme, a 3-bit data partition would have to be used, giving a 32 bx buffer for sending raw data. One such compression scheme is proposed in [5]. Another solution would be to try to clock the ECAL chip outside of its specifications at 60 MHz and send a 24-bit word in 1.5 bx, which would be very likely to cause synchronisation problems.

3. LINX PROTOTYPING ENVIRONMENT

3.1 Design Goals

The LINX test board has been designed as a higher speed replacement for a similar board described in an earlier paper [6]. The board can be used to study the characteristics of different link components and to evaluate their suitability for use in CMS data links. It can also be used in radiation tolerance tests to monitor, for example, single event effects during irradiation. Special attention has been paid to providing a programmable test bench for the CMS RPC fibre optic trigger and data links. Together with some additional hardware, the board can be used to replace the missing components of the RPC readout system during the development phase, and when the final link boards have been manufactured, it can serve as a programmable debugging device to facilitate their maintenance. All aspects of the CMS RPC data transfer can be studied with a modular test bench built from LINX boards and simple adaptor/driver daughter cards.

3.2 Specifications

LINX is a PCI board that can also be used in stand alone mode through either an RS-232 or a USB interface.

The key component on the board is Xilinx Virtex FPGA, containing from 50,000 to 800,000 logic gates and offering operating speeds well in excess of 100 MHz. Different size FPGAs having the same footprint will be mounted on the boards to test the functionality of the VHDL code for LMUX and LDEMUX and to find the optimum FPGA/ASIC size for their implementation. In the PQF package chosen for the board, the components have over 120 configurable pins in total.

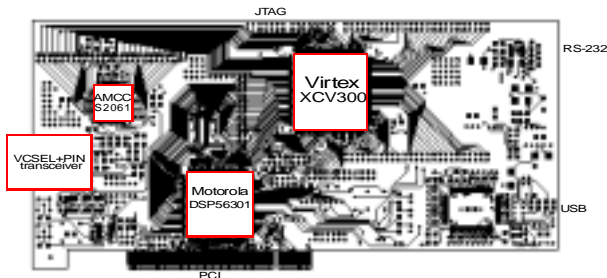

Fig. 3. LINX board

The LINX includes an on-board fibre optic interface based on the AMCC S2061 serial backplane device and a commercial short wavelength optoelectronic transceiver component (VCSEL+PIN diode). The DSP is used mainly for interfacing purposes. There are also numerous connectors where daughter cards or other external inputs/outputs can be connected. Several different daughter cards were designed for the old version of the board, and these can also be used with the new board. Daughter cards exist for Gigabit Ethernet transceivers from different manufacturers and the HP G-link, among others.

3.3 Test Program

Initial synthesis results show that the RPC data compression and decompression algorithms can almost certainly be fitted into the Virtex FPGAs in their full versions and that there will also be some space left for additional test logic. Essentially all the features planned for the RPC data link can be realised on the LINX board, and we should have a proof of principle for the most important features of the data transmission by the end of the year.

For a realistic setup, the system clock can be replaced with a 40.08 MHz input from a TTCrx board via a lemo connector, and RPC-like test data can be generated in the DSP or a host computer and stored into a look-up table on the Virtex, where it can be cycled at the required speed.

Another crucial task to be carried out with a setup based on LINX boards is the single event effect (SEE) testing of link components and FPGAs. Fig. 4 shows an RPC readout chain realised with two LINX boards (a) and a radiation test setup with one board (b). In addition to

fibre optic link components, Channel Link and other LVDS components will be evaluated.

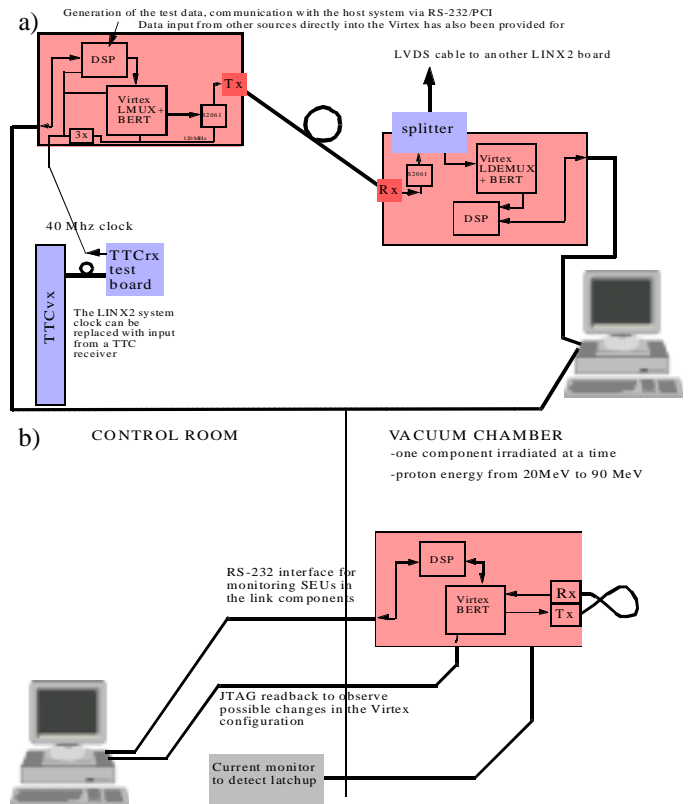

Fig.4a) Test readout chain for the CMS RPC
b) LINX SEE test setup

3.4 Status of the VHDL Development

The VHDL code for the LMUX and LDEMUX is virtually complete, only some of the test functions still remain to be implemented.

Simulation results show that the decompression could be realised even with a Xilinx Spartan series 40k FPGA, whereas the multiplexer part of the compressor seems to require the highest speed grade Virtex. These results are worst case estimates, since they were obtained for a design which did not use any optimisation techniques specific for the Virtex components.

The choice between ASIC and FPGA should be made soon. A decisive factor for the transmitter will be the radiation tolerance of the Virtex FPGAs. At the receiving end, FPGAs will almost certainly be used.

4. IRRADIATION TEST RESULTS

4.1 Gamma Irradiation Tests

Gigabit Ethernet and Fibre Channel components from several different manufacturers (see Table 1 for details) have been irradiated to see whether they would stand the dose present at the CMS muon detectors and in the

cavern. The work was carried out at the ^{60}Co irradiation facility at the Department of Radio Chemistry, University of Helsinki. The dosimetry was based on doses measured for water at certain distances from the source. Since the samples were placed close to the source, the amount of scattered radiation present on them could be minimised, and the silicon equivalent accuracy was around 20%. This was considered to be enough for these first tests.

Table 1. Irradiated components

Part Number	Description
TQ9501-MC	Triquint Fibre Channel Tx
VSC7135QN	Vitesse GE transceiver
CXB1589R	Sony GE transceiver
VSC7115QJ	Vitesse GE Tx
HDMP-1022/HDMP-1024	HP G-link Tx/Rx chipset
S2061B	AMCC GE compatible trans.
S2046B/S2047B	AMCC GE Tx/Rx chipset
VCSEL Transceivers	
Honeywell HFM2450	
Siemens V23826-K305-C73	
HP HFBR-5305F	

The estimated worst case dose at the RPC detector is 100Gy, and this was used as the basic dose in the tests. A significant number of components was irradiated to 200Gy and some up to 300Gy. Components were mounted on small circuit boards and were powered up. On the transceivers with optoparts attached, a fixed data pattern was fed to the transmitter side to modulate the laser. Functionality of the components was checked immediately after the irradiation where possible. More detailed measurements were carried out with the help of an oscilloscope within few hours of the irradiation, after which many of the samples were put through an accelerated aging test at 100°C for one week.

No significant changes were observed in the operating current or functionality of any of the components neither immediately after the irradiation nor after the accelerated aging test. The biggest change in operating current, $\Delta I=70\text{mA}$, was observed for the HP G-link components, which received a dose of 200Gy and were put through the aging test. No other changes were observed in their operation.

4.2 Proton Irradiation Tests

The sensitivity to displacement damage of the optoelectronic and bipolar components was investigated with protons. The proton irradiations were carried out with 75 MeV protons from a multicusp ion source at the University of Jyväskylä K130-cyclotron. The beam current was 180 pA, and the samples were all irradiated

to a total dose (fluence) of $5 \times 10^{12} \text{ ncm}^{-2}$. The beam current was measured by a Faraday cup in the beam line. Fluence was measured by a set of four collimated CsI(Tl) scintillators with PIN diode readout, situated in front of the beam entrance to the vacuum chamber where the devices under test were placed. A more detailed description of the irradiation facility can be found in [7].

As with the gamma irradiation studies, no change was observed in the functioning of the components, or their operating current. The current was measured before and after the irradiation and one month later, when the radioactivity of the samples had gone down to a more acceptable level. The only noticeable change occurred for the HP G-link components, for which the operating current increased from 880 mA to 920 mA after the irradiation and to 940 mA one month after the irradiation.

Altogether the results from both kinds of irradiation test look promising: total dose or displacement damage effects are not likely to be a problem on the CMS muon detectors for the components we have chosen. In a way the results were also disappointing, since we were not able to exclude any of the components with these simple tests. It has to be noted, though, that the sample sizes were rather small (2-3 pieces of each component for the gamma irradiation and 1 piece of each component for the proton irradiation).

In addition to the link components, one Virtex XCV300 FPGA was also irradiated with protons to see whether it would suffer any permanent damage. We have not yet analysed the results.

The next step is to do single event effect tests. For technical reasons, it has been decided to perform the latchup and SEU tests with protons, which at energies above 20 MeV behave in a very similar way to neutrons, with possibly a neutron irradiation in a reactor to check for the effects of low-energy neutrons. Another reason that supports the use of protons rather than neutrons is that preliminary calculations show charged hadrons to dominate the SEU rate even in the CMS cavern, where they form only 1% of the total hadron flux [8].

The plan is to perform latchup measurements for different proton energies to establish the LET of the components, and SEU tests for the serdes components and Virtex FPGAs with the help of the LINX board. The FPGA configurations needed for these tests are under preparation.

5. CONCLUSIONS

The full RPC data transmission chain is to be built this year with LINX boards. This highly modular setup is very suitable for testing the data compression and multiplexing scheme, signal splitting at the receiver end and the overall integrity of the proposed solution.

In the first irradiation tests we were unable to exclude any of the candidate components on the basis of a poor radiation tolerance. It is to be stressed, however, that the

results are very preliminary and single event effect tests are still to be done. The sample size was also rather limited. More tests, concentrating on the components we have chosen for our baseline design, will be carried out soon.

References

- [1] A. Ranieri. Private communication.
- [2] M. Gorski, I. M. Kudla and K. Pozniak. High speed data transmission and compression for the cms rpc muon trigger. Proceedings from the 3rd Workshop on Electronics for LHC Experiments, 1997, London.
- [3] A. Marchioro. Proposal for a Gb/s link for LHC experiments, CMS workshop on optical links, January 1998.
- [4] P. Denes, ECAL optical links, CMS workshop on optical links, January 1998.
- [5] K. Banzuzi and E. Pietarinen. A Data Compression Algorithm for CMS RPC Detector Readout with Fibre Optic Links, HIP Preprint Series HIP-1997-75/EXP.
- [6] E. Pietarinen. A Fibre Optic Link Evaluation and Test System LINX, HIP Preprint Series HIP-1997-76/EXP
- [7] A. Virtanen, J. Hyvönen, K. Ranttila, I. Rekikoski and J. Tuppurainen. Heavy ion and proton test site at JYFL-accelerator laboratory. Department of Physics, University of Jyväskylä, preprint 16/98.
- [8] M. Huhtinen. RD49 Workshop presentation, June 1999.

Acknowledgements

We would like to thank Mika Huhtinen, Pertti Aarnio, Pierre Jarron and Federico Faccio for their help with planning the irradiation tests, Prof. Timo Jaakkola and Laboratory Manager Martti Hakanen of the University of Helsinki Radiochemistry Department, and Prof. Juha Äystö and Dr Ari Virtanen of the University of Jyväskylä Accelerator Laboratory, for the permission to use their facilities and their help.