

PRODUCTION OF INTENSE HIGHLY CHARGED ION BEAMS WITH SERSE

S. Gammino, L. Celona, G. Ciavola, M. Castro, F. Chines, S. Marletta
 INFN-Laboratori Nazionali del Sud, Via S. Sofia 44, 95123 Catania, Italy

G. Melin, P. Briand, A. Girard, P. Ludwig, P. Seyfert, D. Guillaume
 CEA/DRFMC, 17 Rue des Martyrs, 38041 Grenoble, France

Abstract

The source SERSE is operational at LNS since June 1998 and many improvements have been carried out since then. The frequency has been increased from 14.5 GHz to 18 GHz and the use of two frequency heating has given positive results. The chamber insulation was improved, so that the source can be operated now up to 30 kV. The high temperature oven for metallic ion production has been mounted and it will be tested through next weeks. Tests of magnetic field scaling at different frequency have been carried out and they have confirmed the results of previous tests with SC-ECRIS at lower frequency, suggesting that the source upgrading to higher frequencies may be considered.

1 THE INSTALLATION AT LNS

The design of the superconducting Electron Cyclotron Resonance (ECR) ion source SERSE (fig. 1), described in many previous papers [1,2,3,4,5], was based on the concept of High B mode [1,6]. The main features of the source are described in tab. 1.

Frequency	18 GHz + 14.5 GHz
Type of launching	WR62, off-axis
Axial maxima distance	490 mm
B_{\max} (injection side)	2.7 T
B_{\min}	0.3 to 0.6 T
B_{\max} (extraction side)	1.6 T
Resonance zone length	< 100 mm
Hexapole length	700 mm
B_{rad} (at chamber wall)	1.55 T maximum
Biased disk	300 to 600 V, 1 to 2 A mA
plasma electrode	8 mm
puller	12 mm
Extraction voltage	30 kV max

Tab. 1: The main features of SERSE

In fig. 1 it is shown the plasma chamber (= 130 mm.) surrounded by the hexapole, which is enclosed into a structure on which the solenoids are placed. Both the hexapole and the solenoids are made by superconducting wires. On the right there are the microwave and gas injection, and on the left the three-electrode movable

extraction system. A biased disk is placed on-axis at the injection side and can be moved along the same axis. Pumping units at the injection and extraction side provide an operational vacuum of a few 10^{-8} mbar, without plasma (typical values with gas and plasma are 1 to 4 10^{-7} mbar). The source construction started in fall 1993 and in 1995 all the components were operational, except the hexapole, which was able to attain only 70% of the nominal field, a value which did not meet our request to operate the source in High B mode (i.e. with a magnetic field exceeding the value of $2 \cdot B_{\text{ECR}}$, where B_{ECR} is the resonance magnetic field, corresponding to 0.52 T for the frequency of 14.5 GHz and 0.64 T for the frequency of 18 GHz). Therefore we could not accept the magnets and we ordered new superconducting magnets, which delayed the project for two years.

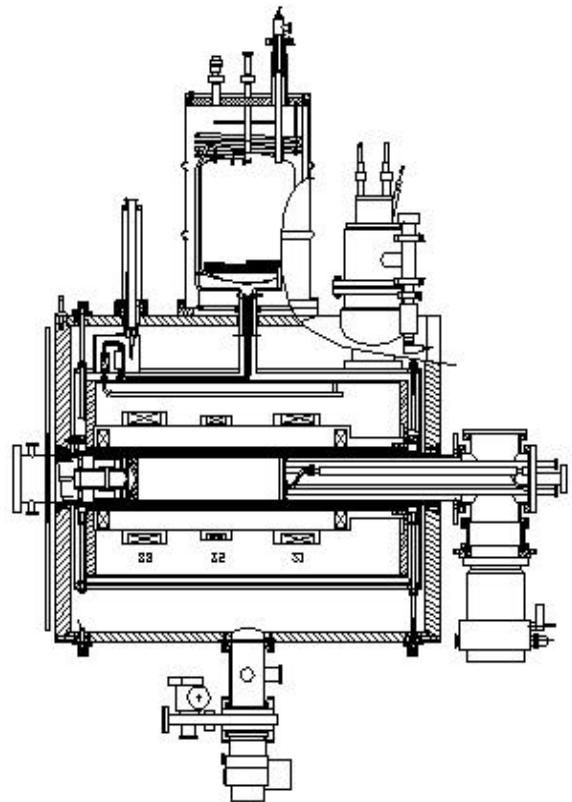

Fig. 1 - The SERSE source.

In spring 1997 the new magnets were ready and operating above the specification [2] and in summer 1997 the first beams of highly charged ions were obtained, with already excellent performance. The tests on the bench site of Grenoble [4] were completed in March 1998 and the source was moved to LNS, where it was operated at 14.5 GHz since June, for a few months.

When the source was installed at LNS, two kinds of problems limited the reliability. The first problem was a poor HV insulation, both on the chamber and on the microwave DC break, because the source was originally designed for lower voltages. The dc break was changed with a more robust mechanical design and a 1.0 mm polypropylene sheet (a simple mechanical polishing of the external surface of the chamber was also done, because a too rough surface triggered the discharge) replaced the chamber insulation sheet. Since then 20 kV operations have become reliable and we demonstrated also the reliability of operations up to 30 kV through few days, as required by the K-800 Superconducting Cyclotron axial injection [7].

The second problem was about cryogenics: there was a larger helium consumption of the cryostat, which was settled by step-by-step optimization of the LHe dewar pressure, in order to limit the losses in the refilling, and there was a bad efficiency of LHe transfer from the main reservoir to the SERSE dewar, which was settled only recently by replacing a part of the cryogenic transfer pipe. Now the LHe consumption is below 4 l/h and the Dewar must be refilled seven times per month, according to the design.

On the other way, the operations with the superconducting magnets were fully reliable and no more quenches happened since the end of training, in July 1998, except for a re-training quench without consequences, due to a partial warm-up of the coils (magnets temperature attained 160 K during the summer stop). After this incident, we have not permitted anymore to the magnet temperature to rise above 77 K.

As for the currents of highly charged ions measured at 14.5 GHz at LNS, they were slightly higher than the ones measured at CEA, Grenoble, because of a higher pumping speed in the extraction region (charge exchange process affected less the high charge states buildup). The most of time was spent for Krypton and Xenon which were never tested there, and that featured current values for the highest charge states largely exceeding (tab. 2) the best results obtained by the other ECR ion sources.

2 THE FREQUENCY UPGRADING

In a recent paper [8] we estimated that the source SERSE, operated with an 18 GHz generator, should increase its plasma density of about 60%, as compared to 14.5 GHz operations and then an increase of current of the same order of magnitude was expected. The condition for an effective upgrading is that the magnetic field is also scaled with the frequency (B_{ECR} is proportional to frequency).

In fig. 2 the axial magnetic field is shown; the profile was more or less the same for the two frequencies, if a

normalization factor f_2/f_1 is used; the radial confining field was also increased from 1.1 T to 1.45 T.

Except for a few cases, a significant increase of currents was observed, as described in tab. 2. It needs to be pointed out that the test with increased frequency were carried out with a lower available power (our 18 GHz generator is able to supply only 1100 W, in spite of nominal 1500 W). A further increase of currents will be obtained with higher RF power, once that the 18 GHz generator will be repaired.

	14.5 GHz	18 GHz	14+18	A.I.E.	optimum
O ⁷⁺	200		208		
O ⁸⁺	40		55		
Ar ¹⁴⁺	80		84		
Ar ¹⁶⁺	17		21		
Ar ¹⁷⁺	1		2.6		
Ar ¹⁸⁺	0.05		0.4		
Kr ²²⁺	46	66			
Kr ²⁵⁺	20	35			
Kr ²⁷⁺	4.5	7.8			
Xe ³⁰⁺	12	17	21.2	27	38.5
Xe ³¹⁺	7.6	10.3	14.7	18.3	23.5
Xe ³³⁺	1.5	3.3	6	7.2	9.1
Xe ³⁴⁺	1	1.6	3	4.1	5.2
Xe ³⁶⁺	0.4	0.9	1.3		2

Tab. 2: Typical currents (in eμA) produced by SERSE (all the currents are measured at 15 kV except for last column, which refers to 25 kV operations with improved vacuum).

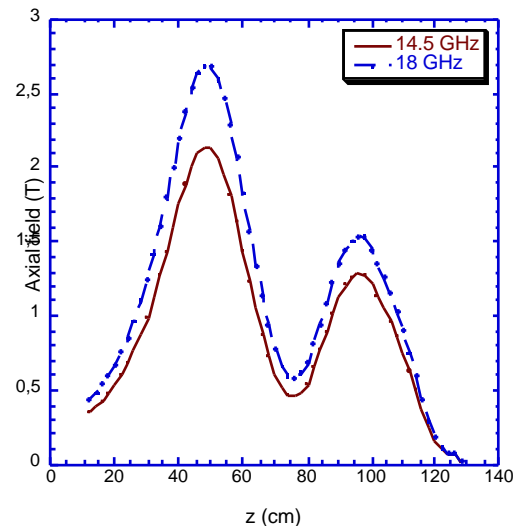

Fig. 2 – Axial magnetic field of SERSE.

3 TWO FREQUENCY HEATING

Recently we have began to operate the source with the “two frequency heating” and the results have not been clear, although the currents were higher. The two frequency heating was more effective in the case that the volume of the

second resonance was narrow and the amount of power was poor (50 to 90 W). In this case an average increase of 20 of the xenon currents was measured for the highest charge states, because of the higher plasma density and of the presence of two resonance surfaces. In fig. 3 a typical charge state distribution for Xe is shown (power was 1040 W at 18 GHz and 60 W at 14.5 GHz). Charge states up to 38⁺ were clearly observed just by decreasing the gas input. The reproducibility of the values in tab. 2 was excellent (within a few %) and the stability over a few hours was acceptable.

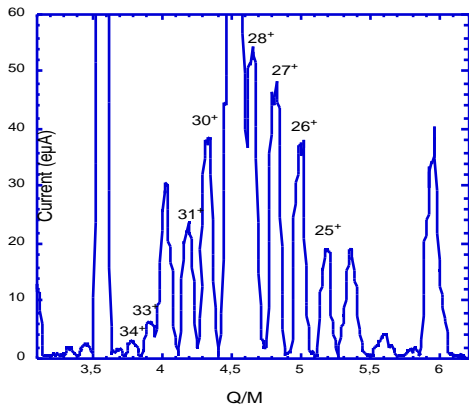

Fig. 3 – Charge state distribution for Xe, optimized for 30⁺.

4 ANOMALOUS ISOTOPE EFFECT AND OTHER FEATURES

These impressive results were not obtained only with the higher frequency but even other factors played a role, as the improvement of chamber conditioning and the use of ¹⁸O as mixer, according to the experience gained at KVI with the “anomalous isotope effect” [9]. Following the suggestion of A.G. Drentje, we changed the mixer, by using ¹⁸O₂ in place of ¹⁶O₂, used as standard mixer. The result was a remarkable increase of currents (>20%) for highly charged Xenon ions. We repeated the same experience for Krypton, but in this case the current increase was moderate with respect to the one of Xenon (about 10%). We also used different other mixers, as ¹⁵N, ²⁰Ne, ²²Ne, and it came out that they are worse than ¹⁶O₂, whereas ¹⁸O₂ is the best mixer for the highest charge states according to [9,10] (fig. 4).

Another relevant improvement consisted of the decrease of the base pressure in the extraction region, obtained by inserting a 1200 l/s getter pump after the 600 l/s turbomolecular pump following the solenoid (fig. 5 shows the analysis section of the beamline to the cyclotron). The base pressure decreased from 3 to 1*10⁻⁸ mbar, increasing the currents of highly charged ions (last column in tab. 2) and improving the stability of the extracted beam.

Recently we replaced the two pumps with a 1000 l/s TMP. Last upgrading of the source consisted of the mounting of an oven [11] that can be used for many types of metallic ions, the other being obtained by means of the sputtering method [12] or by laser ablation [12]. The oven has been mounted and tests will begin in the next weeks.

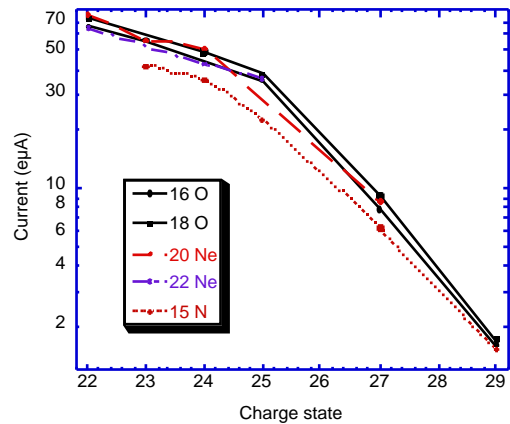

Fig. 4 – Krypton current with different oxygen isotope.

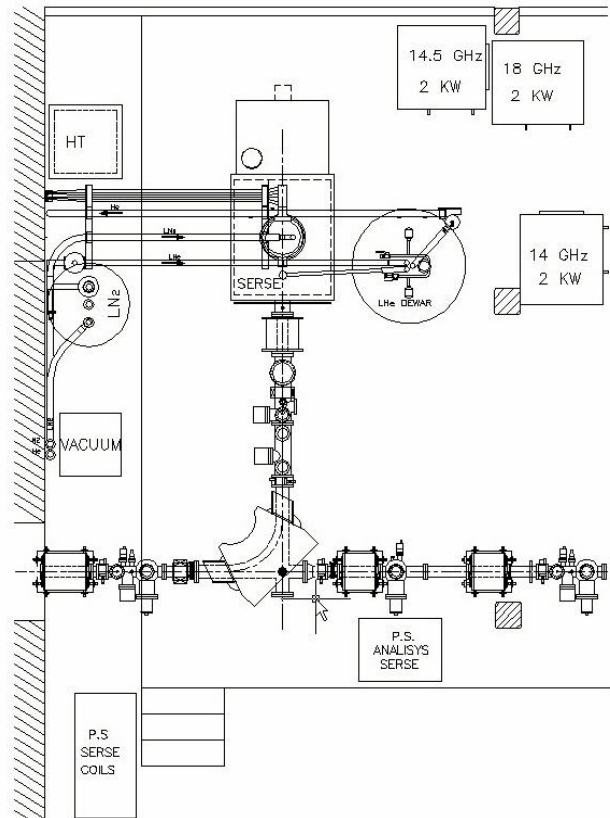

Fig. 5 - SERSE with the analysis section of the beamline.

5 TESTS OF SCALING

Systematic tests about the magnetic field scaling for the operations at 14.5 GHz and 18 GHz were carried out with the same procedure already used for SC-ECRIS at Michigan State University [13]. The trend that was observed for SERSE was quite similar to the one reported in [13]. The currents increase up to value around $B_{\text{radial}} = 2 \cdot B_{\text{ECR}}$ then they remain stable or decrease. In fig. 6 the currents are plotted

versus the radial magnetic field for 14.5 and 18 GHz, featuring a similar trend but a higher current for the higher frequency. For axial field scaling (fig. 7) a value above $4 \cdot B_{\text{ECR}}$ on the injection side and $2 \cdot B_{\text{ECR}}$ on the extraction side improves the plasma stability, as already observed for SC-ECRIS. In fig. 8 the comparison between the results of SERSE and the ones of SC-ECRIS is presented for O^{7+} . It can be seen that, except for the absolute values of the current, the shape of the curves is quite similar for the two sources. The maximum current is not scaled with the square of frequency, as it is foreseen by the Geller's scaling laws, because space charge effects at the extraction play a role (total current is above 4 mA for SERSE, well above the SC-ECRIS values). It can be concluded that the frequency scaling is effective, provided that the magnetic field is high enough, as we underlined some years ago [6].

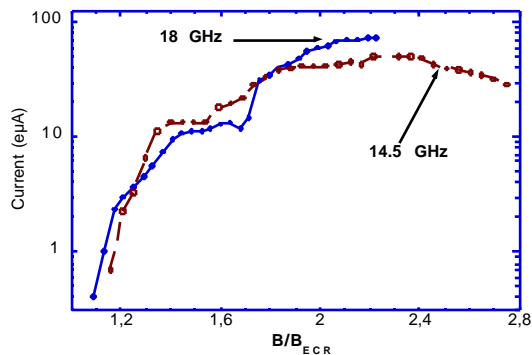

Fig. 6 – Xe^{27+} currents vs. $B_{\text{radial}}/B_{\text{ECR}}$.

6 PERSPECTIVES

In conclusion, the 18 GHz upgrading, along with the two frequency heating and anomalous isotope effect, have permitted to increase enormously the SERSE currents for highly charged ions. The results that we have obtained with SERSE have confirmed the validity of our choice to build an ECR ion source with superconducting magnets, even if the time for the construction has been long and the investments have been relatively high. In fact, the operations of the Superconducting Cyclotron will benefit of the performance of SERSE, which allows to boost the currents extracted from the cyclotron and also to rise the energy, especially for the heaviest ions. The former result is particularly important, because the EXCYT project [14] needs high currents of fully stripped light ions (up to 7 μA) that cannot be provided with the radial injection by means of the Tandem followed by a stripper.

More developments are scheduled for the next future, especially the study of different methods of metallic ion production and the study of two frequency heating. We have also bought recently an 8-18 GHz generator, which will be useful to study systematically the effects of frequency on the ion production. This study will be crucial for the future upgrading to 28 GHz, to be carried out in fall 1999, in the framework of collaboration with CEA and ISN of Grenoble, GSI and CERN [15].

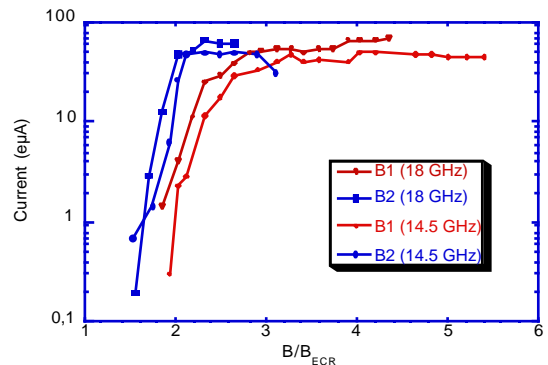

Fig. 7 – Xe^{27+} currents vs. $B_{\text{axial}}/B_{\text{ECR}}$ on injection (1) and extraction side (2).

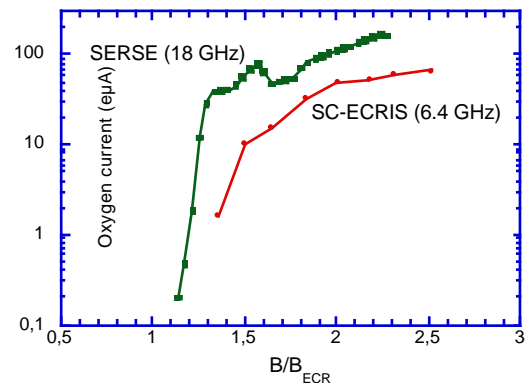

Fig. 8 – O^{7+} current vs. $B_{\text{radial}}/B_{\text{ECR}}$.

7 ACKNOWLEDGEMENTS

The authors acknowledge the expertise of E. Messina in the solution of mechanical problems and thanks M. Cafici, A. Pagano and F. Speziale for the solution of cryogenic problems. We thanks S. Pulvirenti and S. Cavallaro for their support for the contribution to computer controls.

8 REFERENCES

- [1] G. Ciavola, S. Gammino, Rev. Sci. Instr. 63(4), (1992) 2881
- [2] P. Ludwig et al., Rev. Sci. Instr. 69(2), (1998) 653 and refs. therein
- [3] P. Ludwig et al., Proc. 13th Workshop on ECRIS, College Station (1997), 119
- [4] P. Ludwig et al., Rev. Sci. Instr. 69(12), (1998) 3312
- [5] S. Gammino et al., "18 GHz upgrading of the superconducting ECR ion source SERSE", submitted to Rev. Sci. Instr.
- [6] S. Gammino, G. Ciavola, Plasma Sources Science & Technology 5, (1996), 19
- [7] D. Rifuggiato et al., "First years of operation with the Superconducting Cyclotron", Proc. of the 15th Conf. on Cyclotrons and Appl., Caen, June 1998, in press
- [8] S. Gammino, G. Ciavola, Rev. Sci. Instr. 69(8), (1998), 3081
- [9] A. G. Drentje, Proc. 13th Workshop on ECRIS, Groningen (1993), 155
- [10] G. Melin, A.G. Drentje, A. Girard, D. Ditz, to be published on Phys. of Plasmas
- [11] G. Di Bartolo et al., Rev. Sci. Instr. 69(2), 1998, 725
- [12] R. Harkewicz et al., Proc. 12th Workshop on ECRIS, RIKEN (1995), 126
- [13] S. Gammino et al., Rev. Sci. Instr. 67 (12), (1996) 4109
- [14] G. Ciavola et al., Proc. of 1999 Part. Acc. Conf., New York, in press
- [15] N. Angert et al., these proceedings