

Modelling: From Physics to Systems

Kees Stam *Philips Research Laboratory, Eindhoven, The Netherlands*

Abstract

In this paper we introduce system modelling as the sequel to physics modelling in the industrial environment. The example of Electro Magnetic Compatibility modelling of consumer electronics systems is used to illustrate the concept.

Keywords: system modelling; electro magnetic compatibility; consumer electronics

1 Introduction

In recent years a shift has occurred in the focus of industrial research in electronics companies. Whereas in the past physics and materials science were the most important sources for innovation, we now see emphasis on software and system design. For example, in the case of consumer electronics products, new products are mostly defined on the basis of existing modules. Important aspects in such a system approach to product design are perceived quality aspects by the end user and optimisation of the various subsystems to provide optimal functionality at the lowest possible cost. Modelling has become an important tool to aid the designers of such products. Classically, Computer Aided Engineering tools were used to optimise the thermal, mechanical or electromagnetic behaviour of components and subsystems. In the system approach modelling can play an important role as well. First of all modelling speeds up the design: fewer prototypes have to be built. But modelling also helps the designer to better optimise a system and to understand the robustness of a design against variations. The problem that we face in system modelling is the following. We cannot simply extend the use of our classical Computer Aided Engineering tools to system level. The size and complexity of the systems prohibit such an approach (we cannot solve Maxwell's equations for a CD player!). In the system level modelling approach one therefore builds a hierarchical model in which at the lowest level the classical physical simulators are the building blocks. At higher levels effective modelling is required. In the next Sections we will describe one such example of system modelling. This concerns the modelling of Electro Magnetic Compatibility (EMC) properties of consumer electronics products[1].

2 Electro-Magnetic Compatibility

All electronics products produce electromagnetic fields that pollute their environment: they can produce unwanted interferences in other electronic systems. This pollution is increasing because of our increased use of (portable) electronic equipment and because of the use of digital electronics with ever higher operating frequencies. Strict regulations have been made by the EC to ensure that this EM pollution stays within safe limits. Producers have to obey to these regulations in order to get permission to sell their electronics products on the European market. EMC plays a role inside electronic systems as well. Subsystems can influence each other in an unwanted manner, or components and/or metallic interconnections can cause unwanted interferences.

Traditionally test facilities are used to measure the EMC characteristics of electronic products. Obviously, the possibility to simulate EMC behaviour would be of great value. One would not only save the effort of building a number of prototype products, but also simulations can provide insight in the mechanisms of origin and propagation of EMC effects.

We have therefore set out to produce a suite of simulation tools that enable EMC system simulation. We recognise 3 levels in a consumer electronics system: Integrated Circuit (IC),

Printed Circuit Board (PCB) and system level. On IC and PCB level our tools aim at providing equivalent electric circuit models that can be used in a standard circuit simulator.

3 IC Package Modelling

The source of EMC problems often lies in the use of specific IC technologies or packages. High frequency disturbances arising within the IC can lead to signal integrity problems. The specific layout of an IC package with its pins, diepad and bondwires can cause unwanted crosstalk effects.

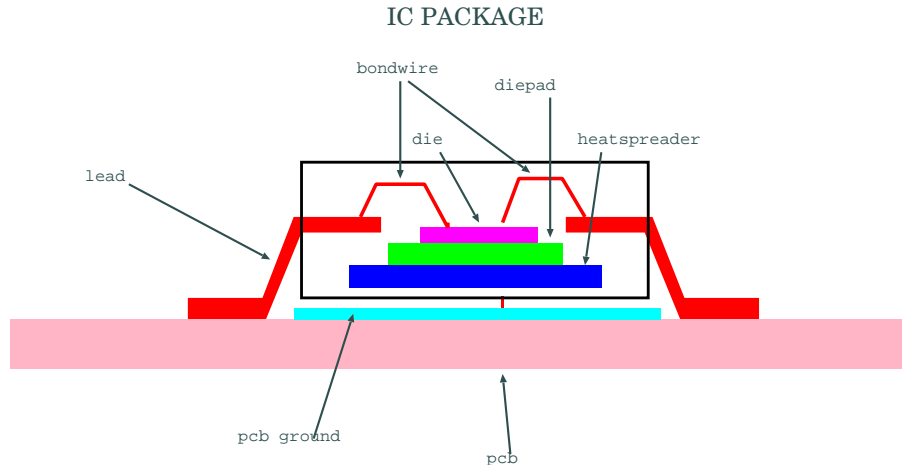

Figure 1: Metallic parts in IC package

We developed a tool to characterise the EMC behaviour of IC packages. Output of the tool is an equivalent electric circuit description of the IC package. This description can then be added to the standard active and passive circuit elements on a PCB for a full functional circuit simulation, including the parasitic IC package effects.

The EMC analysis of an IC package proceeds as follows. First, the geometric data from all metallic parts (diepad, bondwires, leads, pins) are read in from a design system. Then, the metallic areas are discretised. This discretised model can then be used for numerical analysis. We use an integral method, which enables solving the electric and magnetic potential problems without the need to discretise more than the metallic parts. The presence of a ground plane is assumed. The result of the computation is a huge set of parasitic capacitances and inductances between the individual elements. In the pins, these can be added to produce the final results: tables of capacitances and inductances between the pins and between individual pins and the diepad.

4 PCB Modelling

The Printed Circuit Board level is usually the most critical for EMC behaviour. The interconnect lines can act as antennas (both source and receiver) to EM fields. The operating frequencies of present day consumer products (up to 1 GHz) create radiation problems through this antenna effect, but also due to crosstalk and interference effects within the PCB.

Our PCB level simulation tool analyses the full interconnect and ground structure of a PCB. The tool interfaces to a traditional PCB layout system. After reading in the PCB layout, the interconnect and ground structures are meshed automatically. This is also implemented for multi

layer PCB's, where the meshes of subsequent layers are chosen so as to give optimal computational fit. Given this meshed structure an integral method is used to solve for the electric and magnetic potentials in all the individual elements. In practice this is done using a Green's function method for solving the potential problem. In a multilayer PCB with layers of different permeability the Green's function can become quite complicated and much increase in computational speed can be gained by proper approximations. The result of this computations is an equivalent circuit model of the interconnect and ground structure of the PCB. In fact this model contains all the individual capacitances and inductances between all the elements in the computational model. Many of these contributions are close to zero. Again, increase in computational speed can be gained by neglecting certain contributions and by grouping the effects of a number of elements together. In this way a typical PCB can be meshed with several thousands of elements, leading to millions of inductances and capacitances, which are then compressed to thousands of circuit components[2].

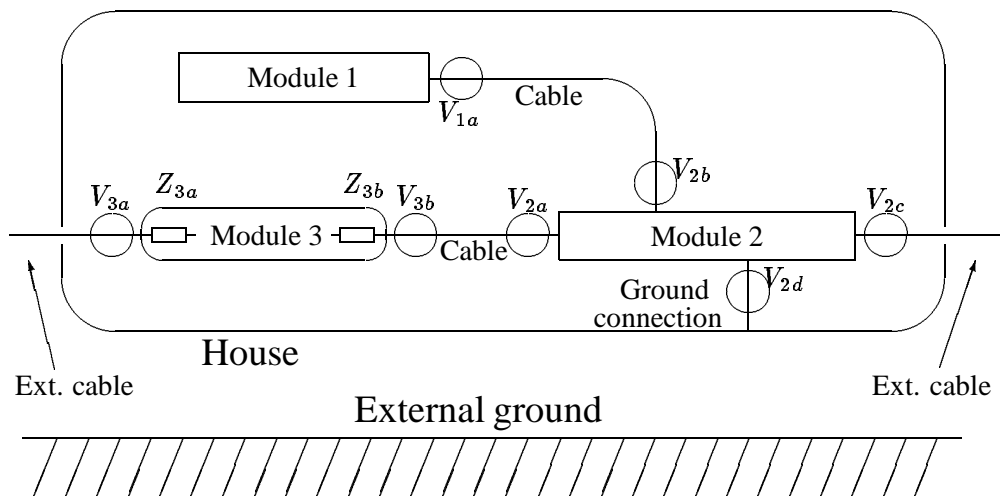

Figure 2: Example of meshed PCB

The circuit components that characterise the interconnect structure are then combined with the active and passive components that are mounted on the PCB into one circuit model. This model is analysed with a circuit simulator which provides the exact current distribution in all elements in the PCB at given operational boundary conditions. This current distribution is the basis for the computation of the radiated EM field. Similarly, irradiation can be modelled by adding sources to the equivalent circuit model.

The output of the EMC simulation at PCB level is twofold. The radiated field (or the susceptibility to irradiation) can be computed. This is relevant if nearby other PCB's are present, or if one needs to know the far field effects. In the second place the exact current distribution in the PCB is known, also at its terminals. The latter is also an important result as it determines which disturbances are brought to other PCB's or the outside world through cables attached to the PCB. The net currents that flow in this way are called common mode currents.

In practice these are very CPU intensive computations despite the approximations and numerical efforts that were made. Both for the integral method EMC solver and for the circuit simulator we are studying the options for parallelisation.

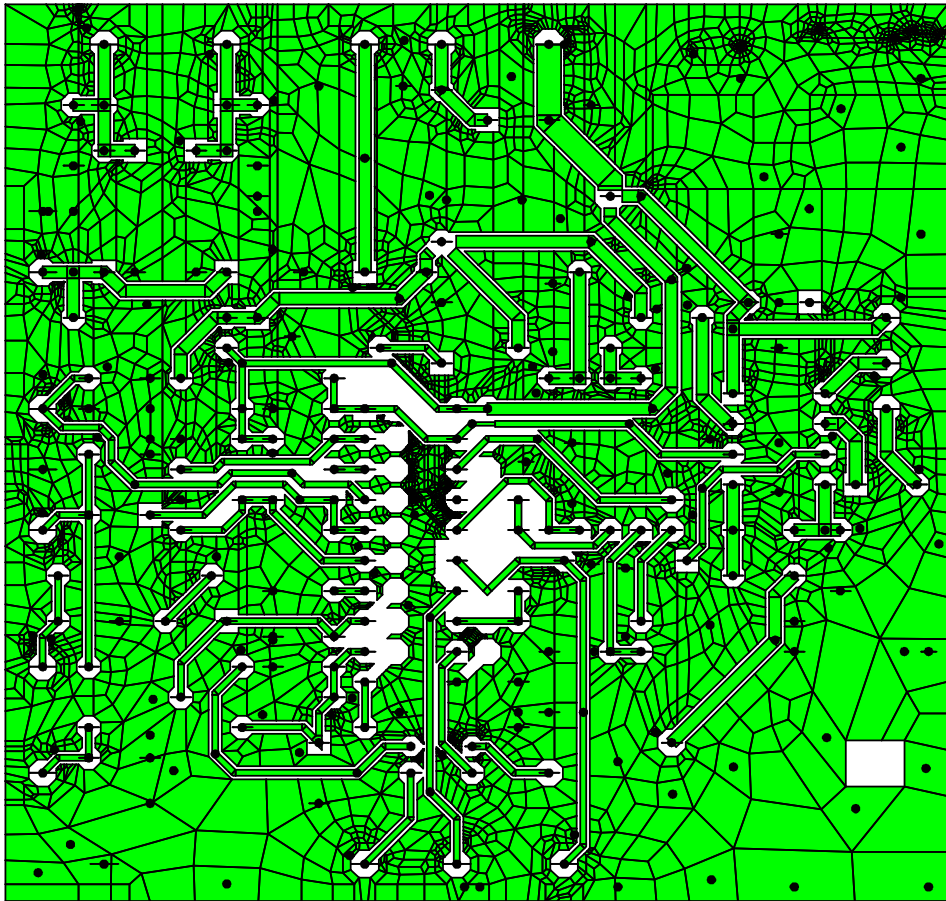

Figure 4: EMC system analysis for audio system

version control for these complex models. The system level tools will consist of simulation tools which are specific to the application at hand and of generic tools. These will be used for system optimisation and inspection of complicated parameter spaces.

References

- 1 Cloux, R. du, W.J. de Graaf, G.P.J.F.M. Maas, R.W.C. van der Veeke, *EMC simulations and measurements*, Proceedings of the 11th International Zürich Symposium on EMC (1995).
- 2 R. du Cloux, G.P.J.F.M. Maas, A.J.H. Wachters, *Quasi-static boundary element method for electromagnetic simulation of PCBs*, Philips Journal of Research, Vol. 48, (1994), p. 117.