

EUROPEAN ORGANIZATION FOR NUCLEAR RESEARCH
CERN — SL DIVISION

CERN SL-99-048 BI

**PERFORMANCE OF THE NEW SPS BEAM POSITION ORBIT
SYSTEM (MOPOS)**

Boccard, C.; Bogey, T.; Brazier, J. Ltd; De Vries, J.; Jackson, S.; Jones, O.R.;
Papis, J.P.; *Rawnsley, W.; Rybaltchenko, K.; Schmickler, H.

CERN – Geneva – CH
*TRIUMF

Abstract

The orbit and trajectory measurement system COPOS of the CERN SPS accelerator has been in operation since the construction of the machine in 1976. Over the years the system has been slightly modified in order to follow the evolving demands of the machine, in particular for its operation as a p-pbar collider and, since 1991, for the acceleration of heavy ions.

In 1995 the performance of the system was reviewed and the following shortcomings were identified:

- lack of turn-by-turn position measurements due to the 1ms integration time of the voltage to frequency converters used for the analogue to digital conversion (to be compared with a revolution time of 23 μ s),
- ageing effects on the 200 MHz resonating input filters, which had over the years drifted out of tolerance. As a consequence the signal to noise ratio, the linearity and the absolute precision were affected,
- the calibration system based on electromechanical relays had become very unreliable, such that frequent calibrations were no longer possible,
- a remote diagnostic for the observation of timing signals relative to the beam signals was missing.

For the above reasons a large-scale upgrade program was launched, the results of which are described in the following sections.

*Presented at DIPAC
Chester – 16-18 May 1999*

Geneva, Switzerland
August, 1999

PERFORMANCE OF THE NEW SPS BEAM POSITION ORBIT SYSTEM (MOPOS)

C. Boccard, T. Bogey, J. Brazier Ltd, J. de Vries, S. Jackson, R. Jones,
J.P. Papis, W. Rawnsley (TRIUMF), K. Rybaltchenko, H. Schmickler.

SL Division- European Laboratory for Particle Physics (CERN) - Geneva - Switzerland

Abstract

The orbit and trajectory measurement system COPOS of the CERN SPS accelerator has been in operation since the construction of the machine in 1976. Over the years the system has been slightly modified in order to follow the evolving demands of the machine, in particular for its operation as a p-pbar collider and, since 1991, for the acceleration of heavy ions.

In 1995 the performance of the system was reviewed and the following shortcomings were identified:

- lack of turn-by-turn position measurements due to the 1ms integration time of the voltage to frequency converters used for the analogue to digital conversion (to be compared with a revolution time of 23 μ s),
- ageing effects on the 200 MHz resonating input filters, which had over the years drifted out of tolerance. As a consequence the signal to noise ratio, the linearity and the absolute precision were affected,
- the calibration system based on electromechanical relays had become very unreliable, such that frequent calibrations were no longer possible,
- a remote diagnostic for the observation of timing signals relative to the beam signals was missing.

For the above reasons a large-scale upgrade program was launched, the results of which are described in the following sections.

1. DESCRIPTION OF THE NEW SYSTEM

1.1 Analogue processing chain

The new Multi Orbit Position System (MOPOS) is based on 200 MHz homodyne receivers, which follow a pair of matched 4.4 MHz bandpass filters. In order to enable the system to measure both high intensity proton beams and low intensity heavy ion beams, the dynamic range has been increased to 90 dB with the help of front-end low noise amplifiers. The resulting signal is then sampled or peak-detected, depending on the type of beam, and sent to the acquisition boards as a serial stream after conversion in 14 bit ADCS (see Figure 1).

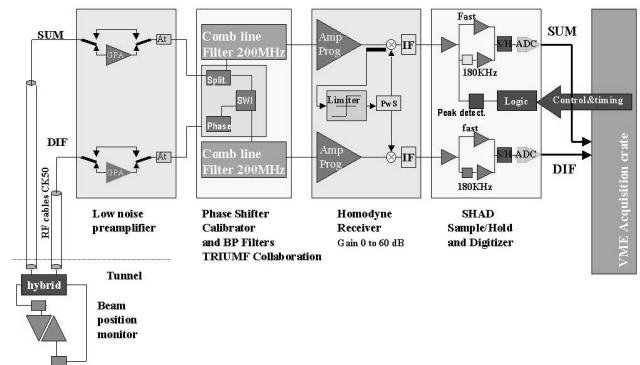

Figure 1: Synoptic of a MOPOS chain.

1.2 Acquisition architecture

The acquisition system is based around the CERN-SL standardised PowerPC (RIO2 8062) and makes full use of its memory, interfaces and processing power.

Using 3 VME slots, the CPU and 2 PCI extension boards can accept up to 6 PCI mezzanine cards (PMC). Each PMC can process data from 20 ADC channels (10 pickups). After treatment in a dedicated FPGA, a FIFO collects the acquired data in synchronism with the SPS revolution frequency. Sampling every 23 μ s gives a data stream of 8Mbytes/s.

The local PCI DMA controller transfers the data from each FIFO to the main memory at a rate of 70Mbytes/s. A total of 224 Mbytes of memory enables turn by turn data for up to 40 BPMs of a complete SPS super-cycle of up to 28s to be stored.

1.3 Software architecture

The 240 channel SPS Orbit acquisition system is implemented on 6 PowerPCs. These run under the LynxOS operating system, making use of its multi threaded real-time capabilities. Orbit acquisitions process the raw data on request. Calibration and initialisation data tables are stored externally in an Oracle database and locally in a non-volatile RAM board to enable a fast restart.

2. NEW FUNCTIONALITIES

2.1 Multi-turn capability

The previous acquisition system, based on voltage to frequency converters, was not able to give position data on a turn-by-turn basis. By using 14 bit ADCs to sample each SPS turn, the MOPOS system can store multi-turn data, which can then be used in the computation of any relevant machine parameter. The idea is to store each turn of each elementary cycle of the SPS machine, such that the system has a multi-cycle, multi-user capability.

Some examples of the types of simultaneous acquisitions that can occur are listed below:

- Transfer line steering requiring data from the first machine pick-ups.
- Injection optimisation requiring a first turn reading.
- Observations of kicks or bumps requiring a thousand turn reading from several pick-ups.
- Orbit readings (i.e. the 1ms to 20 ms average of beam position data) occurring at any time in the cycle.
- Extraction optimisation using the phase advance measurement that is calculated by the harmonic analysis of transverse excitation signals from the last horizontal BPM before each extraction line.
- Miscellaneous studies - e.g. in 1997, the in-depth analysis of noise on the MOPOS prototype was used to find a noisy extraction power supply [1].

2.2 New calibration hardware and RF filters

Due to the differences between the beams in each elementary SPS cycle (protons, electrons, positrons or heavy ions), the system must be calibrated for each of these machine cycles, and for each receiver gain. Single bunches induce a ringing excitation in the pair of 200MHz filters whereas a train of bunches permits the tracking of a quasi-continuous signal. The new MOPOS filters for the sum and difference channels provide a minimum of 60dB isolation and a 55° phase shift capability to compensate for cable delays.

As part of the LHC SPS upgrade collaboration with the TRIUMF laboratory in Canada a new solid state calibrator was developed which allows frequent calibrations to be performed. The 200 MHz combline filters mentioned in the PAC 97 paper [2] had their cases constructed from 1.5 mm brass sheets, which were folded and soldered to form a box. This technique was not consistent enough to ensure that all pairs were matched to within 3 degrees over the central 1 MHz region. For the production run of 300 pairs a more robust design from Lorch Microwave was used. The new filter cases are machined from aluminum blocks, which gives a much better reproducibility. A minimum wall thickness of 4.8 mm was also introduced for improved rigidity.

Tuning, testing and recording of the calibration parameters for each module was automated with test sequences written to run on a HP 8753D network analyzer. The analyzer was programmed to set the calibrator mode and the phase shifter voltage for each of 62 tests, and prompted the Aimtronics technician to change cable connections and perform tuning procedures when necessary. An example of the results of such a test can be seen in Figure 2.

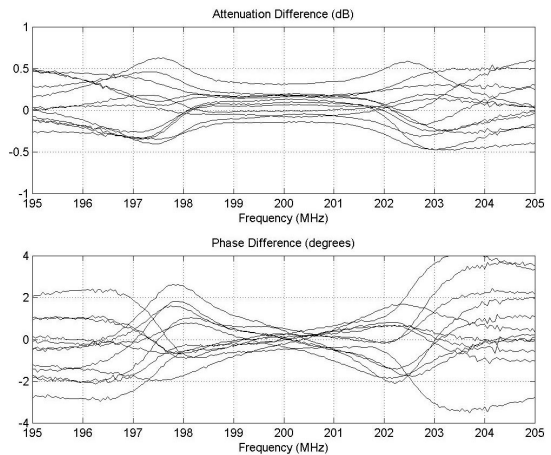

Figure 2: The attenuation and phase matching of 12 pairs of filters. The phase matching easily satisfies the required < 3 degrees over the central 1 MHz region.

2.3 Graphical User Interface

System configuration aspects were implemented in a Broker architecture, where individual threads communicate with an Oracle database and with the acquisition systems.

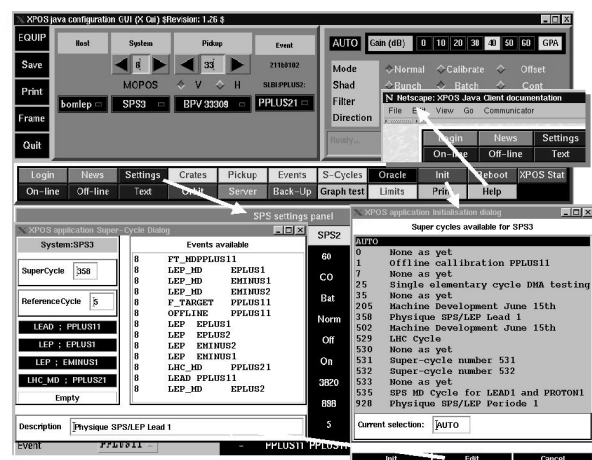

Figure 3: Xpos Java configuration graphical user interface.

This Broker hides the implementation details of the front-end systems. A versatile configuration client is provided in Java, which allows for local graphical user interfaces from any platform and remote WWW access using a dedicated gateway to the SL equipment layer.

2.4 Expert tools

2.4.1 Remote Scope

For diagnostic and timing adjustment purposes, each building is equipped with a GPIB controlled oscilloscope. A signal multiplexer allows the selection of either the sum, difference or timing signal for each channel. Settings are archived and retrieved from the Oracle database.

This diagnostic is integrated in a LabView application, which provides the graphical user interface and allows for data retrieval via the SL-EQUIP package (see Figure 4).

MOPOS timing diagnostic system: scope TDS210 / multiplexors

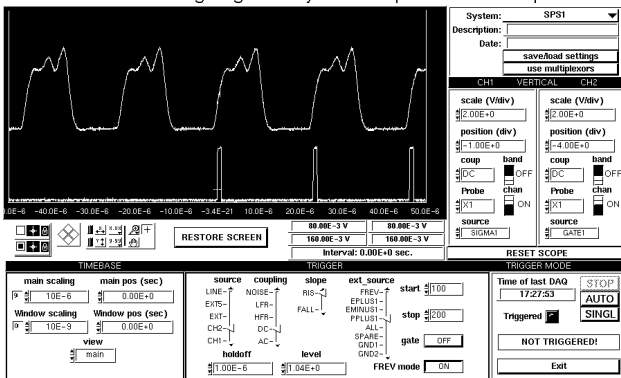

Figure 4: Scope and multiplexer - LabView interface.

2.4.2 Multi-turn trajectories display

A graphical interface is also provided to display up to 1000 turns of the sum signal and either the difference or the position versus time for up to ten selected pick-ups.

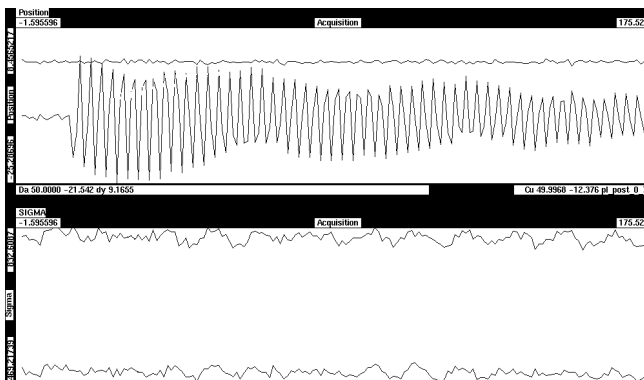

Figure 5: A trajectory on the multi-turn display after a transverse kick (measured on a heavy ion beam)

2.5 Performance

With a proton beam and a gain of 10 dB, the resolution of a 42mm aperture horizontal pick-up is 0.03 mm peak-to-peak, equivalent to a 5 micron rms on the orbit position (Figure 6).



Figure 6: Noise on proton trajectories.

With an ion beam, a gain of 70 dB is necessary [3], and a resolution of 0.51 mm peak-to-peak is obtained (Figure 7).

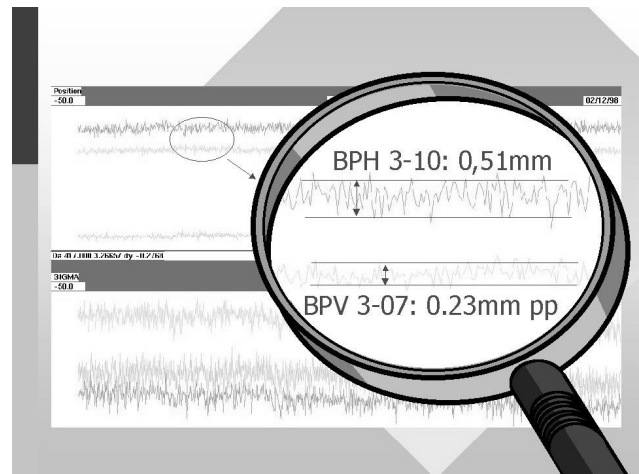

Figure 7: Noise on ion trajectories.

REFERENCES

- [1] O. Berrig, "Noise in BA6", SL-BI., 1997.
- [2] W. Rawnsley, "An RF Signal Processing Module for the SPS Orbit Observation System Upgrade", Proceedings of PAC'97, Vancouver, June 1997.
- [3] : C. Boccard, "Performances de Mopos", Journee de l'instrumentation, SL-BI, Dec. 1998., SL-Note-98-078(BI)