

EUROPEAN ORGANIZATION FOR NUCLEAR RESEARCH  
CERN — SL DIVISION

CERN SL-99-043 BI

**BEAM PROFILE MEASUREMENTS AT 40 MHz IN THE PS TO  
SPS TRANSFER CHANNEL**

Feroli, G.; Gras, J.J.; \*Hiller, H.; Jung, R.

CERN – Geneva – CH

\*Bruun & Sorensen (France)

**Abstract**

Bunch to bunch beam profile measurements provide a valuable tool to control the injection lines to the SPS.

A fast profile monitor based on a 2.5  $\mu\text{m}$  Mylar coated with Aluminium Optical Transition Radiation (OTR) radiator, has been developed, installed and tested in the transfer line between the PS and SPS.

The OTR beam image is focused onto a fast Linear Multianode Photo Multiplier Tube and the associated electronics sample and store profiles every 25 ns.

The paper describes the detector design, the electronic processing, and presents the results of different measurements made with bunches of  $10^9$ - $10^{11}$  protons at 26 GeV, and bunches of  $10^6$   $\text{Pb}^{82}$  ions at 5.11 GeV/u.

*Presented at DIPAC  
Chester – 16-18 May 1999*

Geneva, Switzerland  
August, 1999

# BEAM PROFILE MEASUREMENTS AT 40 MHz IN THE PS TO SPS TRANSFER CHANNEL

G. Ferioli, J.J. Gras, \*H. Hiller, R. Jung  
CERN, Geneva, Switzerland - \*Bruun & Sørensen (France)

## Abstract

Bunch to bunch beam profile measurements provide a valuable tool to control the injection lines to the SPS.

A fast profile monitor based on a 2.5 $\mu$ m Mylar coated with Aluminium Optical Transition Radiation (OTR) radiator, has been developed, installed and tested in the transfer line between the PS and SPS.

The OTR beam image is focused onto a fast Linear Multianode Photo Multiplier Tube and the associated electronics sample and store profiles every 25ns.

The paper describes the detector design, the electronic processing, and presents the results of different measurements made with bunches of  $10^9$ - $10^{11}$  protons at 26 GeV, and bunches of  $10^6$  Pb<sup>82</sup> ions at 5.11 GeV/u.

## 1. INTRODUCTION

In the transfer line between PS and SPS different types of beams have to be monitored for a good injection in the SPS. For the Fixed Target operation 2 injections of  $2 \cdot 10^{13}$  p at 14 GeV and 10.5  $\mu$ s long are extracted horizontally in 5 PS turns. With the ions, 4 injections of 16 bunches of  $1.5 \cdot 10^6$  Pb<sup>82</sup> ions each at 5.11 GeV/u and spaced by 140 ns are used.

In view of the use of the SPS as LHC injector one injection of 16 bunches of  $10^9$  protons each at 26 GeV and spaced by 140 ns, is presently used for preliminary tests and, from this year one injection of 83 bunches spaced by 25 ns will be tested. For all beams the rms vertical and horizontal sizes are measured by Secondary Emission Grids (SEG) and OTR Beam Television Profiles (BTP).

The SEG electronics integrates all the signals coming from the grids for each injection at intervals defined by the master timing and gives only a single H/V profile. The CCD camera, used in the BTP monitor, integrates the signals during a TV frame (20ms), and the associated processing system computes a single H/V projection and a 2-Dimensional representation [1]. In both cases the evolution of the position, relative intensity, and profiles of the different bunches or structures is lost.

A new fast system able to acquire H/V profiles of bunches spaced by 25ns has been developed, installed in the transfer line and tested with different beams.

## 2. THE EXPERIMENTAL SET UP

Many OTR radiators made of 12  $\mu$ m Titanium or 25  $\mu$ m Mylar coated with 2  $\mu$ m of Aluminium are currently used in the transfer lines to the SPS. These screens generate light, which reproduces the time structure of the beam and bunches spaced by 25ns can be analyzed [2].

The intensity of the OTR radiation, generated by ion or proton bunches injected in the SPS, is high enough to provide good diagnostics with a CCD camera or a Photomultiplier.

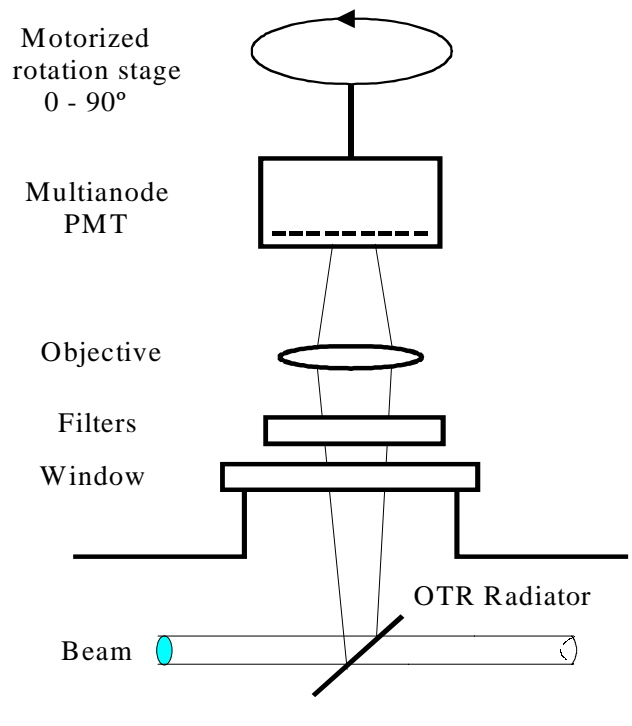

Figure 1: Schematic view of the monitor set-up

The measurement station (Fig. 1) uses a standard BTV SPS tank, where an OTR radiator is placed at 45° with respect to the beam. The radiation, through a window on the vacuum chamber and a set of neutral density filters, is focused by a 75 mm objective onto a Multianode Photo Multiplier Tube (MPMT).

This MPMT (type: Hamamatsu R5900U) with the proximity focusing dynode structure preserves the spatial distribution of intensity between photocathode and anode. This tube is a linear structured version with 16 anodes measuring 0.8\*16 mm with a 1mm pitch, and an anode pulse rise time of about 0.6 ns.

A motorized rotation stage can rotate the MPMT from 0° to 90°, so with the same monitor, this allows to take alternatively horizontal or vertical profiles. The set of filters, the gain of MPMT and the rotation stage are remotely controlled.

Fig. 2 shows the detector with the acquisition electronics system mounted on the same support.

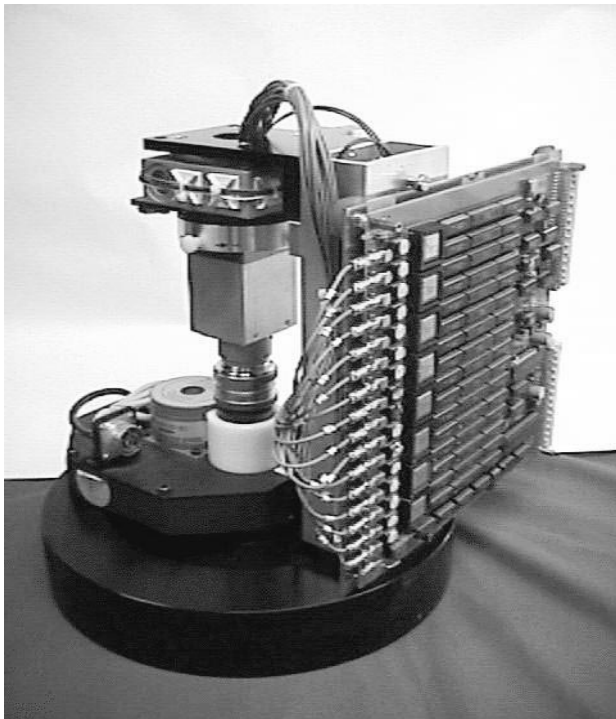
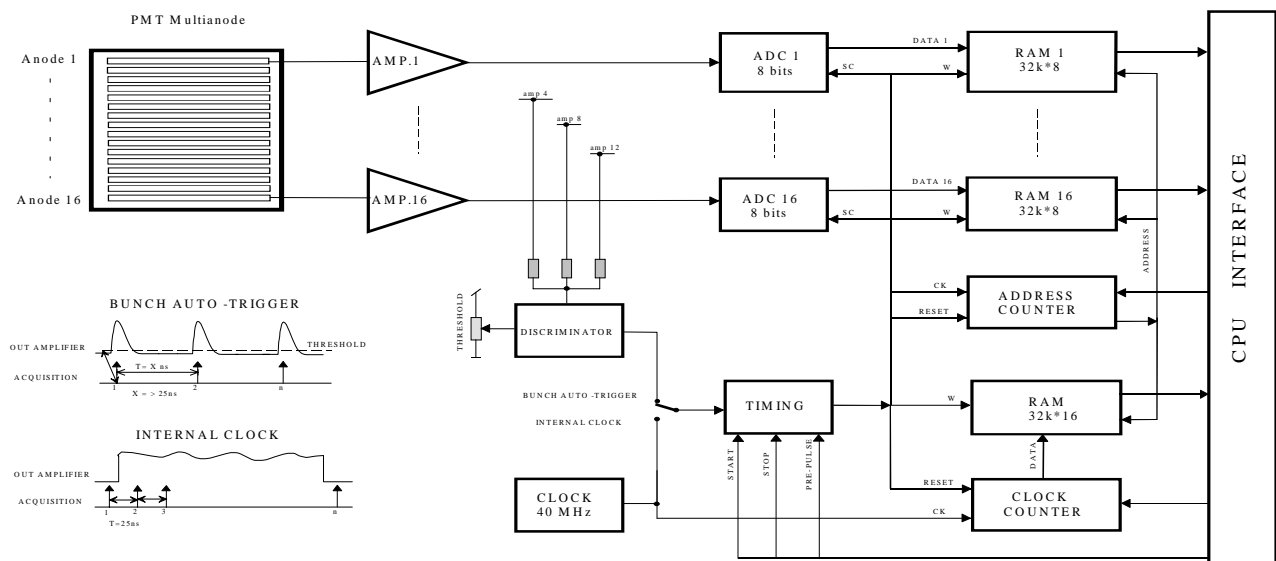

**Figure 2:** Fast Beam Profile Monitor

### 3. READOUT ELECTRONICS

A new wide band readout electronics has been developed, in order to digitize and store simultaneously 16 signals at a frequency up to 50 MHz (Fig. 3).

Very short cables connect the output of each anode of the MPMT to an amplifier (used to limit the anode current). This analog signal is digitized by an 8 bits flash ADC



**Figure 3:** Bloc diagram of MPMT readout electronics.

and the sampled values are stored in an internal memory of 32 Kbytes.

Two modes of operation have been foreseen: internal clock and bunch auto trigger to work correctly with the different beam structures. In the internal clock mode, used with the continuous transfer of 5 PS turns, an external gate synchronous to the injection resets the counter memory and starts the acquisition process and an internal clock at 40 MHz stores the profiles in the memory.

The bunch auto trigger mode is used to analyse bunched beams; in this case the external gate is used to reset the counter memory and to generate an "enable" for the acquisition process.

A very fast low-level discriminator detects the presence of an analog signal on the anodes, generated by one bunch, and starts one conversion for all channels. The bunches have to be separated by at least 25ns.

In both cases at the end of the injection, on request of the CPU installed in a surface building, the data are transferred to a VME interface over a serial RS 422 line.

### 4. SOFTWARE DESCRIPTION

The software system is based on a client-server architecture. The server is located in the front-end CPU, a PowerPC VME card (type: CES RIO-8062) running the LynxOS real time system. It has been developed in C and consists in two threads. The first one acquiring continuously the profiles at predefined events (first proton injection, second proton injection...), the second handling the communications with the outside world. On the client side, a graphical user interface has been developed for our HPUX workstations. It allows the user to configure the observed events, to monitor the system settings (PM voltage, acquisition plane..) and of course to retrieve, display (Fig. 4, 6) and store the acquisitions via the server communication thread.

## 5. EXPERIMENTAL RESULTS

Profile measurements have been done with ions: Fig. 4 shows the horizontal profiles of the four batches, of 16 bunches each, used in the injection of one SPS cycle.

The system has shown the peculiar behaviour of the first bunch of each batch, a phenomenon impossible to see with the others profile monitors installed in the transfer line.

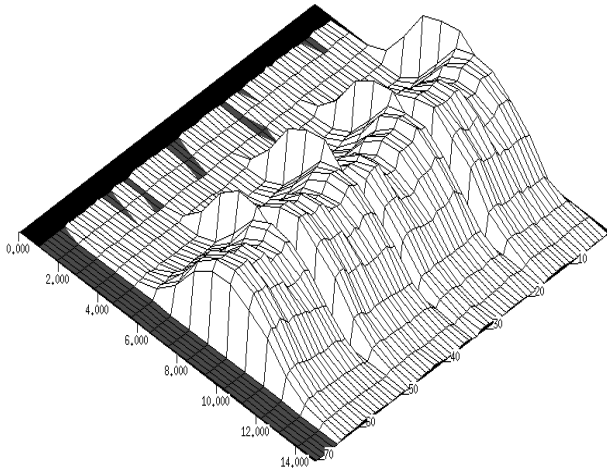

**Figure 4:** Horizontal profiles of 4 batches of Pb ions of 16 bunches each (from right to left).

In order to correct this problem the timing of the CPS extraction kicker was changed; Fig. 5 shows that the monitor was able to follow the evolution of the position of the bunches. This test has revealed that the length of the kicker pulse was not long enough to perform a good ejection.

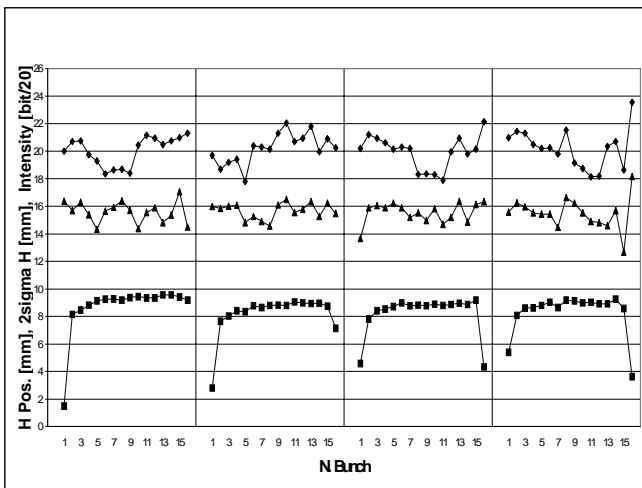
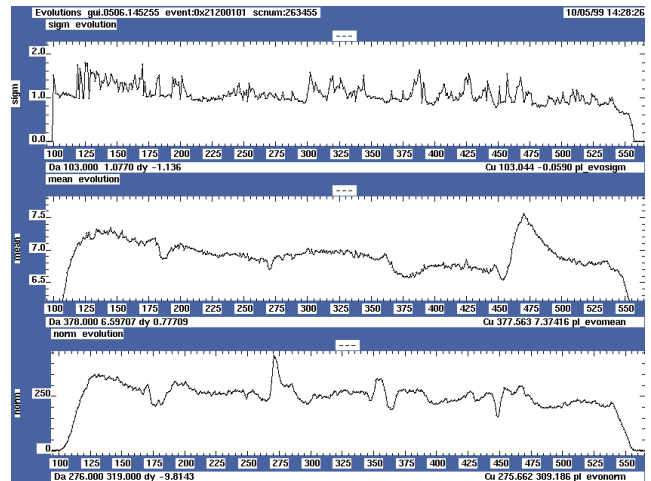

**Figure 5:** Evolution of first ions batch during the timing tuning of the CPS extraction kicker.

The relative intensity, the position and the beam sizes along the spill of the beam delivered by 5 CPS turns in

Continuous Transfer mode have been measured by means of the processing of about 600 profiles acquired during the injection (Fig. 6).

The observation and the improvement of the transverse characteristics of this proton beam are simplified.



**Figure 6:** Evolution of: rms size, position and intensity of 5 CPS turns injected in the SPS.

## 6. CONCLUSION

Single bunch to bunch measurements, by the Fast Beam Profile Monitor, have proven to be feasible. Some phenomena, which would pass undetected by SEM Grid or BTP monitor profile, have been highlighted.

The OTR screen does not significantly blow-up the beams injected into the SPS, and can be used as a permanent monitoring tool.

This diagnostic tool has been extremely useful in the optimisation of different parameters of the injection line.

The small number of channels of the MPMT can be a disadvantage. A limitation appears when resolutions less than 1 mm are needed; a more sophisticated optical setup would be required to overcome this limitation.

## ACKNOWLEDGEMENTS

We would like to thank J. Camas and M. Sillanoli who performed the mechanical and installation works, and J. Koopman who provided the Step Control for the rotation stage and filters.

## REFERENCES

- [1] J. Camas et al: Screen versus Sem grids for single pass measurements. Pro. of DIPAC 95 Travemunde, Germany 28-31 May 95.
- [2] J. Bossler et al: Optical Transition Radiation proton beam profile monitor. NIM A238 (1985) 45-22.