

## Hadronic Probes of the Polarized Intrinsic Strangeness of the Nucleon

J. Ellis<sup>a</sup>, M. Karliner<sup>b</sup>, D.E. Kharzeev<sup>c</sup> and M.G. Sapozhnikov<sup>d</sup>

<sup>a</sup>) Theory Division, CERN, Geneva, Switzerland

<sup>b</sup>) School of Physics and Astronomy,  
Raymond and Beverly Sackler Faculty of Exact Sciences  
Tel Aviv University, Tel Aviv, Israel

<sup>c</sup>) RIKEN BNL Research Center,  
Brookhaven National Laboratory,  
Upton, New York, USA

<sup>d</sup>) Joint Institute for Nuclear Research, Dubna, Russia

### Abstract

We have previously interpreted the various large apparent violations of the naïve Okubo-Zweig-Iizuka (OZI) rule found in many channels in  $\bar{p}p$  annihilation at LEAR as evidence for an intrinsic polarized  $\bar{s}s$  component of the nucleon wave function. The model is further supported by new data from LEAR and elsewhere. Here we discuss in more detail the possible form of the  $\bar{s}s$  component of the nucleon wave function, interpret the new data and clarify the relative roles of strangeness shake-out and rearrangement, discuss whether alternative interpretations are still allowed by the new data, and propose more tests of the model.

# 1 Introduction

The possible strange quark content of the nucleon is currently of considerable experimental and theoretical interest. It should not surprise anyone that the nucleon wave function might contain a substantial  $\bar{s}s$  component. The analysis of QCD sum rules shows that the condensate of  $\bar{s}s$  pairs in the vacuum is not small, but is comparable with the condensate of the light quarks [1]. The presence of  $\bar{s}s$  pairs in the nucleon was first indicated by measurements of the  $\pi$ -nucleon  $\sigma$  term [2], and by charm production in deep-inelastic neutrino scattering [3]. Over the past decade, the EMC and successor experiments with polarized lepton beams and nucleon targets (SMC, E142, E143, E154, HERMES) [4] have not only confirmed that such  $\bar{s}s$  pairs are present, but also indicated that they are polarized. This latter observation has stimulated great theoretical interest, with chiral soliton models [5] and ideas based on the axial  $U(1)$  anomaly [6, 7, 8] providing competing focuses for the debate [9].

Within this general phenomenological ferment, attention has been drawn back to the Okubo-Zweig-Iizuka (OZI) rule [10] and its applicability to processes involving baryons [11]. The OZI rule postulates that diagrams with disconnected quark loops, e.g., for  $\phi$  decay into  $\pi\pi\pi$  or  $J/\psi$  decay into light hadrons, should be suppressed compared to connected quark diagrams, e.g., for  $\rho$  decay into  $\pi\pi$ . Of particular interest has been the OZI-inspired suggestion that, in reactions involving pions and nucleons, mesons with a predominant  $\bar{s}s$  content, such as the  $\phi$  and the  $f'(1525)$ , should be produced only via their  $\bar{u}u + \bar{d}d$  contents, i.e., via the departures from ideal mixing in their wave functions. However, this prediction would hold only if the pion and nucleon wave functions contained negligible fractions of  $\bar{s}s$  pairs, which, in the case of nucleons, is not supported by the experiments mentioned in the first paragraph.

Indeed, as was pointed out in [11], early data on  $\phi$  production indicated excesses above predictions based on the departure from ideal mixing in the  $\phi$  wave function, especially in low-energy  $\bar{p}p$  annihilation. The interpretation proposed in [11] was that there was additional production by diagrams that are allowed by the OZI rule if the nucleon wave function contains  $\bar{s}s$  pairs. Such a model would predict channel-dependent departures from predictions based on ideal mixing. Other interpretations of the  $\bar{p}p$  data have included the existence of a four-quark  $\bar{q}q\bar{s}s$  meson  $C$  in one particular partial wave [12], and the importance of rescattering via  $K\bar{K}$  and  $K\bar{K}^* + \bar{K}K^*$  intermediate

states [13, 14].

A wealth of new high-statistics data in various  $\bar{p}p$  annihilation channels have recently become available, coming principally from the LEAR experiments OBELIX, the Crystal Barrel and JETSET. These provide information on several final states including  $\phi\gamma$ ,  $\phi\pi$ ,  $\phi\eta$ ,  $\phi\pi\pi$ ,  $f'\pi$  and  $\phi\phi$ , in different experimental conditions which allow initial-state spin and orbital angular momentum states to be distinguished. These data provide unambiguous evidence for the failure of the application of the OZI rule with a naïve nucleon wave function, and provide many hints for the formulation of a more satisfactory model.

In a previous paper [15], we proposed a model based on a nucleon wave function containing negatively polarized  $\bar{s}s$  pairs, as suggested by the EMC and successor experiments. This model opened up the possibilities of  $\phi$  production via shake-out and rearrangement diagrams, whose importance would depend on the initial nucleon-antinucleon states. Some aspects of the model were not specified at first: for example, the partial waves of the  $\bar{s}s$  pair relative to the core of the nucleon wave function, and between the  $s$  and  $\bar{s}$ , were left open. Nevertheless, this model explained satisfactorily many subtle qualitative aspects of  $\phi$  production in  $\bar{p}p$  annihilation, as well as making interesting predictions for  $\phi$  production elsewhere and for other experiments. In particular, the model of [15] was extended to the reaction  $\bar{p}p \rightarrow \Lambda\bar{\Lambda}$  in [16], where arguments were given on the basis of chiral symmetry that the  $\bar{s}s$  pair in the nucleon wave function might be in a  ${}^3P_0$  state. Also, the model of [15] was applied in [17] to make predictions for  $\Lambda$  longitudinal polarization in the target fragmentation region for deep-inelastic lepton scattering.

Even more new data from LEAR and elsewhere have appeared since [15], and they seem to bear out the general features of the model proposed there. The purposes of this paper are the following:

- To refine the arguments of [15] and [16] on the possible form of the  $\bar{s}s$  component in the nucleon wave function;
- To interpret the new data in the light of this model, clarifying the relative roles of shake-out and rearrangement;
- To discuss whether other interpretations are still tenable, in the light of the more detailed experimental information now available; and

- To propose more tests of the model.

## 2 The Naïve OZI Rule and its Apparent Violation

There are different formulations of the OZI rule [10] (for a review, see [18]), which is stated as the suppression of reactions with disconnected quark lines. In order to make quantitative statements it is convenient to use the formulation of Okubo [19]. Consider the production of  $\bar{q}q$  states in the interactions of hadrons

$$A + B \longrightarrow C + q\bar{q} \quad \text{for } q = u, d, s \quad (1)$$

where the hadrons  $A, B$  and  $C$  consist of only light quarks. The naïve OZI rule demands that

$$Z = \frac{\sqrt{2}M(A + B \rightarrow C + s\bar{s})}{M(A + B \rightarrow C + u\bar{u}) + M(A + B \rightarrow C + d\bar{d})} = 0 \quad (2)$$

where  $M(A + B \rightarrow C + q\bar{q})$  are the amplitudes of the corresponding processes.

This means that, if the  $\phi$  meson were a pure  $\bar{s}s$  state, it could not be produced in the interaction of ordinary light-quark hadrons. The OZI rule in Okubo's form [19] strictly forbids the production of strangeonia or charmonia from hadrons composed only of  $u$  and  $d$  quarks. The only way to form a  $\phi$ , according to this rule, is through the admixture of the light quarks in the  $\phi$  wave function. This admixture is parametrised by the parameter  $\delta \equiv \Theta - \Theta_i$ , where  $\Theta$  and  $\Theta_i$  are the physical and ideal mixing angles, respectively. If the mixing angle is ideal:  $\Theta_i = 35.3^\circ$ ,  $\phi$  is a pure  $\bar{s}s$  state. In practice, the physical value of the mixing angle  $\Theta$  may be determined phenomenologically from the masses of the mesons in the corresponding meson nonet.

The naïve OZI rule of (2) may be re-written in terms of the mixing angle  $\Theta$ :

$$\frac{M(A + B \rightarrow C + \phi)}{M(A + B \rightarrow C + \omega)} = -\frac{Z + \tan(\Theta - \Theta_i)}{1 - Z \tan(\Theta - \Theta_i)} \quad (3)$$

If the naïve OZI rule is correct, i.e.,  $Z = 0$ , then

$$R = \frac{\sigma(A + B \rightarrow \phi X)}{\sigma(A + B \rightarrow \omega X)} = \tan^2(\Theta - \Theta_i) \quad (4)$$

which predicts a universal suppression factor for  $\phi$  production relative to  $\omega$  production. However, it is necessary to make a phase-space correction before comparing this ratio with the experimental data.

Using the quadratic Gell-Mann-Okubo mass formula to determine the physical vector-meson mixing angle, one may obtain

$$R(\phi/\omega) = 4.2 \cdot 10^{-3} \quad (5)$$

and the corresponding analysis for tensor mesons yields

$$R(f'_2(1525)/f_2(1270)) = 16 \cdot 10^{-3} \quad (6)$$

Alternatively, the tensor-meson mixing angle may be determined from the  $f'_2(1525)$  decay widths into the OZI-forbidden  $\pi\pi$  and OZI-allowed  $\bar{K}K$  modes:

$$R = \frac{W(f'_2(1525) \rightarrow \pi\pi)}{W(f'_2(1525) \rightarrow \bar{K}K)} = (2.6 \pm 0.5) \cdot 10^{-3} \quad (7)$$

after making the appropriate phase-space correction.

The predictions (5) and (6) were tested many times in experiments using different hadron beams. The analysis [20] of the experiments collected in the Durham reactions data base shows that in  $\pi N$  interactions the weighted average ratio of cross sections of  $\phi$  and  $\omega$  production at different energies is

$$\bar{R} = \frac{\sigma(\pi N \rightarrow \phi X)}{\sigma(\pi N \rightarrow \omega X)} = (3.3 \pm 0.3) \cdot 10^{-3} \quad (8)$$

without attempting to make a phase-space correction. Therefore, in  $\pi N$  interactions, the agreement with the naïve OZI rule prediction (5) is very good, with the result (8) corresponding to a value  $Z_{\pi N} = 0.9 \pm 0.3\%$  for the OZI violation parameter, possibly becoming smaller if phase space is taken into account.

The weighted average ratio of cross sections of  $\phi$  and  $\omega$  production at different energies in nucleon-nucleon interaction is somewhat higher, but still qualitatively similar to the OZI value (5):

$$\bar{R} = \frac{\sigma(NN \rightarrow \phi X)}{\sigma(NN \rightarrow \omega X)} = (14.7 \pm 1.5) \cdot 10^{-3} \quad (9)$$

This corresponds to a value  $Z_{NN} = 8.2 \pm 0.7\%$  for the OZI violation parameter, without attempting to make any correction for the phase-space differences of the final states, which would be non-universal. However, these

would always tend to increase (9) and hence  $Z_{NN}$ . The corresponding values for antiproton annihilation in flight are qualitatively similar:

$$\bar{R} = \frac{\sigma(\bar{p}p \rightarrow \phi X)}{\sigma(\bar{p}p \rightarrow \omega X)} = (11.3 \pm 1.4) \cdot 10^{-3} \quad (10)$$

yielding the value  $Z_{\bar{p}p} = 5.0 \pm 0.6\%$ .

These experiments indicate that the naïve OZI rule for vector meson production is generally valid within 10% accuracy. This is not so bad for a heuristic model, bearing in mind that the OZI prediction is based only on the value of the mixing angle derived from meson masses, and applies at different energies from 100 MeV till 100 GeV. Experimental data on tensor meson production are more scarce, but in general they also confirm the naïve OZI rule prediction (6).

In view of this seemingly comfortable situation, it was a surprise when experiments at LEAR with stopped antiproton showed large violations of the naïve OZI rule (for reviews, see [21, 22]). The largest violation observed is for the  $\bar{p}p \rightarrow \phi\gamma$  channel, where the Crystal Barrel collaboration has found [22] for the ratio of yields for the reactions  $\bar{p} + p \rightarrow \phi(\omega) + \gamma$ :

$$R_\gamma \equiv \frac{\sigma(\bar{p}p \rightarrow \phi\gamma)}{\sigma(\bar{p}p \rightarrow \omega\gamma)} = (294 \pm 97) \cdot 10^{-3}, \quad (11)$$

which is about 70 times larger than the OZI prediction  $R(\phi/\omega) = 4.2 \cdot 10^{-3}$ ! Another very large apparent violation of the OZI rule was found for the  $\bar{p} + p \rightarrow \phi(\omega) + \pi^0$  channels, where the analogous quantity is

$$R_\pi = (106 \pm 12) \cdot 10^{-3} \quad (12)$$

for annihilation in a liquid-hydrogen target [22], and

$$R_\pi = (114 \pm 24) \cdot 10^{-3} \quad (13)$$

for annihilation in a hydrogen-gas target [23]. These ratios are about a factor of 30 higher than the naïve OZI rule prediction!

One of the most striking features of the violation of the naïve OZI rule found in the experiments at LEAR is its strong dependence on the quantum numbers of the initial state. This interesting effect was initially observed by

the ASTERIX collaboration [24] in the  $\bar{p}p \rightarrow \phi\pi^0$  channel. This reaction is allowed from two  $\bar{p}p$  initial states, namely  $^3S_1$  and  $^1P_1$ , but  $\phi$  mesons were observed in the sample with the dominant S-wave content and were not seen at all in the sample corresponding to P-wave annihilation:

$$\begin{aligned} Br(\bar{p}p \rightarrow \phi\pi^0, ^3S_1) &= (4.0 \pm 0.8) \cdot 10^{-4}, & (14) \\ Br(\bar{p}p \rightarrow \phi\pi^0, ^1P_1) &< 0.3 \cdot 10^{-4} & (15) \end{aligned}$$

which is a challenge for model interpretations.

To illustrate that the amount of apparent OZI-rule violation observed in  $\bar{p}p$  annihilation at rest is quite unusual, we compare the  $\phi/\omega$  ratios observed in  $\bar{p}p$  annihilation with corresponding channels in  $J/\psi$  decays:

$$R_{J/\psi} \equiv \frac{B(J/\psi \rightarrow \phi\pi^+\pi^-)}{B(J/\psi \rightarrow \omega\pi^+\pi^-)} = (111 \pm 23) \cdot 10^{-3} \quad (16)$$

Since the initial state is light-flavour-neutral, this gives the ballpark of the ‘natural’  $\phi/\omega$  ratio in a case where both  $\phi$  and  $\omega$  are produced via disconnected quark-line diagrams. It therefore seems surprising that in  $\bar{p}p$  annihilation at rest the  $\phi/\omega$  ratio is of the same order of magnitude as in  $J/\psi$  decays, despite the additional possibility of the  $\omega$  being produced by the rearrangement of light quarks in the  $\bar{p}p$  annihilation case.

To add to the puzzle, there are channels for  $\phi$  meson production in  $\bar{p}p$  annihilation at rest where no OZI-rule violation was observed. For instance, it was found for annihilation in liquid hydrogen that  $R(\phi\eta/\omega\eta) = (4.6 \pm 1.3) \cdot 10^{-3}$  [22], compatible with the naïve OZI rule. Moreover, no large enhancement of  $\phi$  production was observed in the ratio  $R(\phi\omega/\omega\omega) = (19 \pm 7) \cdot 10^{-3}$  [21], and  $R(\phi\rho/\omega\rho) = (6.3 \pm 1.6) \cdot 10^{-3}$  [21] is also compatible with the naïve OZI rule.

One possible interpretation of these facts was proposed in [15], where it was assumed that the nucleon wave function contains polarized  $\bar{s}s$  pairs. Then, there are additional classes of connected quark-line diagrams, and the observed OZI violation is only apparent. It was further proposed that the strong dependence on the initial-state quantum numbers is due to polarization of the strange sea. We next turn to a more detailed study of this proposal.

### 3 The $\bar{s}s$ Component of the Nucleon Wave Function

There are many different possibilities for the quantum numbers of the  $\bar{s}s$  component in the nucleon wave function [25]. We attempt a simplified description of the proton as a combination of  $uud$  and  $\bar{s}s$  clusters and assume, for simplicity, that the quantum numbers of the  $uud$  cluster are the same as for the proton, namely  $J^P = 1/2^+$ . One may then still explore an infinite spectrum of possible quantum numbers of the  $\bar{s}s$  quark cluster. The possibilities involving the lowest relative partial waves are those shown in Table 1.

| S | L | j | $J^{PC}$ | State              |
|---|---|---|----------|--------------------|
| 0 | 0 | 1 | $0^{-+}$ | $^1S_0$ ' $\eta$ ' |
| 1 | 0 | 1 | $1^{--}$ | $^3S_1$ ' $\phi$ ' |
| 1 | 1 | 0 | $0^{++}$ | $^3P_0$            |
| 1 | 1 | 0 | $1^{++}$ | $^3P_1$            |
| 0 | 1 | 0 | $1^{+-}$ | $^1P_1$            |

Table 1: Possible quantum numbers of the  $\bar{s}s$  cluster in the nucleon. We denote by  $\vec{S}$  and  $\vec{L}$  the total spin and orbital angular momentum of the  $\bar{s}s$  pair,  $\vec{J} \equiv \vec{L} + \vec{S}$ , and the relative angular momentum between the  $\bar{s}s$  and  $uud$  clusters is  $j$ .

We see from Table 1 that the  $\bar{s}s$  could be stored in the nucleon with the quantum numbers of either the  $\eta$  or the  $\phi$  if the relative angular momentum between the  $\bar{s}s$  and  $uud$  clusters is  $j = 1$ . However, if  $j = 0$ , the quantum numbers of  $\bar{s}s$  pair may be different, and the vacuum quantum numbers  $J^{PC} = 0^{++}$  become an option. It is clear that the predictions of the model will depend drastically on the assumption about the  $\bar{s}s$  quantum numbers.

The assumption that the  $\bar{s}s$  pair has the quantum numbers of  $\phi$  meson may seem attractive *a priori*, but leads to serious problems. In this case one would expect additional  $\phi$  production due to *shake-out* of the hidden strangeness [15] stored in the nucleon, but it is not clear how to explain the strong dependence of the  $\phi$  yield on the joint quantum numbers of the pair of annihilating nucleons, as first observed by the ASTERIX Collaboration [24]. Moreover, the shake-out of the  $\phi$  mesons stored in the nucleon would lead to



an apparent violation of the OZI rule in *all* reactions. The fact that apparent OZI violation is not seen in some reactions, and is relatively small in some others, as reviewed in the previous Section, seems to exclude this possibility. It seems difficult to explain in this picture why the OZI rule should be obeyed within 10 % accuracy in some cases, but violated by factors of the order of 30 or more in other cases.

Similar arguments were used in [26], where it was demonstrated that the experimental data on the production of  $\eta$  and  $\eta'$  mesons exclude  $0^{-+}$  quantum numbers for the  $\bar{s}s$  admixture in the nucleon wave function.

As an alternative, it was argued in [16] that the  $\bar{s}s$  cluster in the nucleon might be negatively polarized, due to the interaction of the light valence quarks with the QCD vacuum. Due to their chiral dynamics, the interaction between quarks and antiquarks is strongest in the pseudoscalar  $J^{PC} = 0^{-+}$  sector. This strong attraction in the spin-singlet pseudoscalar channel between a light valence quark in the proton wave function and a strange antiquark from the QCD vacuum could result in the spin of the strange antiquark being aligned antiparallel to the spin of the light quark, and hence, on average, to the proton spin. On the other hand, the QCD vacuum is known to contain quark-antiquark pairs with the quantum numbers  $J^{PC} = 0^{++}$ , i.e., in a  ${}^3P_0$  state. A QCD sum-rule analysis [1] indicates that the condensate of the strange quarks in the vacuum is not small compared with the condensate of the light quarks:

$$\langle 0 | \bar{s}s | 0 \rangle = (0.8 \pm 0.1) \langle 0 | \bar{q}q | 0 \rangle, \quad q = (u, d) \quad (17)$$

If the  $\bar{s}s$  pair in the nucleon can be regarded as a  ${}^3P_0$  vacuum excitation, the spin of the  $s$  quark should be aligned with that of the  $\bar{s}$  antiquark, so to preserve the vacuum quantum numbers  $J^{PC} = 0^{++}$ , and hence should also be aligned opposite to the nucleon spin. It is important to stress that the  $\bar{s}s$  pair with  ${}^3P_0$  quantum numbers is not itself polarized, being a scalar. Rather, a chiral non-perturbative interaction selects one projection of the total spin of the  $\bar{s}s$  pair on the direction of the nucleon spin, namely that with  $S_z = -1$ <sup>1</sup>. Since the density of  $\bar{s}s$  pairs in the QCD vacuum is quite high, one might expect that the effects of the polarized strange quarks in the nucleon could

---

<sup>1</sup>We comment, in this connection, that QCD instantons have been shown to induce just such a *negative* quark polarization [27, 28].

also be non-negligible, as suggested by the polarized deep-inelastic scattering data: see also the discussion in [25]<sup>2</sup>.

The above discussion of the sea quantum numbers has an immediate application to the question of contributions of nucleon constituents to its total spin. Consider the sum rule for the total helicity of the nucleon,

$$\frac{1}{2} = \frac{1}{2} \sum_q \Delta q + L_z + \Delta G \quad (18)$$

where  $\Delta q$ ,  $L_z$  and  $\Delta G$  are respectively the quark helicity, the orbital angular momentum of all partons, and the gluon helicity. It is useful to rewrite (18), separating the sea and valence quark contributions to  $\Delta q$  and  $L_z$

$$\frac{1}{2} = \frac{1}{2} \sum_q \Delta q^{val} + \Delta q^{sea} + L_z^{val} + L_z^{sea} + L_z^{glue} + \Delta G \quad (19)$$

If the sea quarks in the nucleon are in  ${}^3P_0$  state, then the total helicity they carry is equal to their orbital angular momentum,  $\Delta q^{sea} = -L_z^{sea}$ . The sum rule then becomes

$$\frac{1}{2} = \frac{1}{2} \sum_q \Delta q^{val} + L_z^{val} + L_z^{glue} + \Delta G \quad (20)$$

and since it is likely that  $L_z^{val} = 0$ , we have

$$\frac{1}{2} = \frac{1}{2} \sum_q \Delta q^{val} + L_z^{glue} + \Delta G \quad (21)$$

The leading-order evolution equations tell us that

$$\frac{d\Delta G}{d \log Q^2} = - \frac{dL_z^{glue}}{d \log Q^2} \quad (22)$$

i.e., to this order the evolution preserves the initial  $(L_z^{glue} + \Delta G)$  one starts with at  $Q^2 = Q_0^2$ . If one starts with a “bare” nucleon in the lowest Fock state  $|uud\rangle$ , with all the helicity carried by its three valence quarks, then

---

<sup>2</sup>These strange quarks should not be considered to be constituent quarks in some five-quark configuration of the nucleon. Rather, they should be considered as components of a constituent quark.

$L_z^{glue} = -\Delta G$ . Plugging this into (21), we recover the naïve quark model result

$$\frac{1}{2} = \frac{1}{2} \sum_q \Delta q^{val} \quad (23)$$

Thus we see explicitly how the helicity sum rule is satisfied. As the bare nucleon gets “dressed” through the addition of sea quarks and gluons, each such addition leaves the total helicity unchanged, since the respective helicity and orbital angular momentum contributions cancel each other.

## 4 Production of $\bar{s}s$ Quarkonium Systems

We now consider the production of  $\bar{s}s$  strangeonia in  $NN$  or  $\bar{N}N$  interactions, assuming the picture outlined in the previous Section, namely that the nucleon wave function contains an admixture of negatively polarized  $\bar{s}s$  pairs in a  ${}^3P_0$  state, i.e.,  $J^{PC} = 0^{++}$ .

The shake-out of such pairs will not create a  $\phi$  or tensor  $f'_2(1525)$  meson, but rather a scalar strangeonium state. No concrete candidate for this state is firmly established (see [29] for a discussion), though the lightest  $\bar{s}s$  scalar may have a mass around 1700 MeV. In this case, the shake-out of the scalar  $\bar{s}s$  pair from the nucleon will be a source of channels with open strangeness, such as  $\bar{K}K$  and  $KK^*$ . Other, identifiable  $\bar{s}s$  systems should be produced by processes in which strange quarks from *both* nucleons participate, and therefore depend on the quantum numbers of the initial  $NN$  state.

One example of such a *rearrangement* diagram is shown in Fig. 1. If the nucleon spins are parallel, as in Fig. 1a, then, in the proposed model, the spins of the  $\bar{s}$  and  $s$  quarks in both nucleons are also parallel. If the polarization of the strange quarks is not changed during the interaction, then the  $\bar{s}$  and  $s$  quarks will have parallel spins in the final state. The total spin of the  $\bar{s}s$  quarks will therefore be  $S = 1$ . If their relative orbital momentum is  $L = 0$ , the produced strangeonium will have the  $\phi$  quantum numbers. On the other hand, if  $L = 1$ , the produced strangeonium will have the  $f'_2(1525)$  quantum numbers.

In the case where the initial  $NN$  state is a spin-singlet, the spins of the  $\bar{s}s$  pair in different nucleons are antiparallel, and rearrangement diagrams like

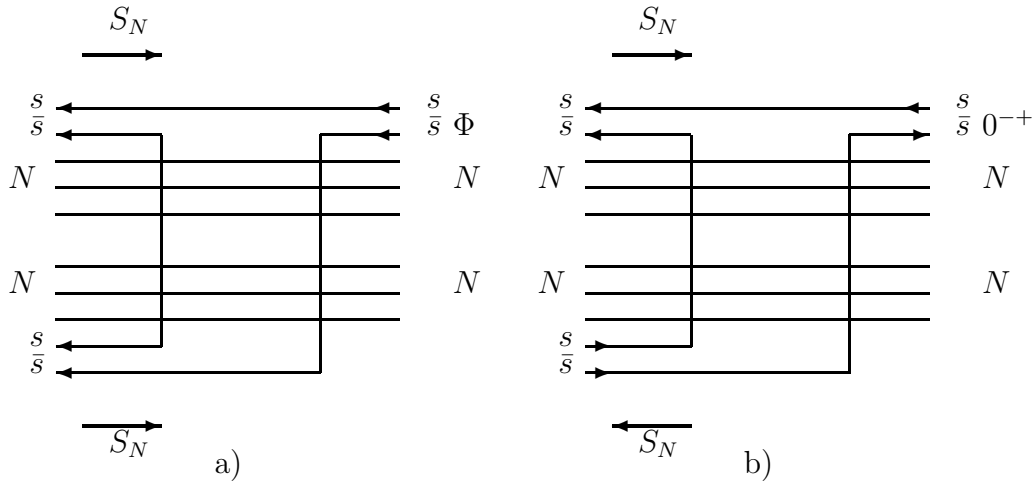

Figure 1: Production of the  $\bar{s}s$  mesons in  $NN$  interaction from the spin-triplet (a) and spin-singlet (b) states. The arrows show the direction of spins of the nucleons and strange quarks.

that in Fig. 1b may produce a final-state  $\bar{s}s$  system with total spin  $S = 0$ . This means that, for  $L = 0$ , a strangeonium state with the pseudoscalar quantum numbers  $0^{-+}$  is produced.

Therefore, in our picture there are always diagrams corresponding to the rearrangement of the  $\bar{s}s$  pairs between different nucleons, but this does not mean that the  $\bar{s}s$  pair is created as a  $\phi$  meson. The predictions of the polarized-strangeness model are quite definite:

- The  $\phi$  should be produced more strongly from the  $^3S_1$  state,
- The  $f'_2(1525)$  should be produced more strongly from the  $^3P_J$  states,
- Spin-singlet initial states favour the formation of pseudoscalar strangeonia.

This mechanism could therefore explain why the  $\phi/\omega$  ratio is not universal in different initial-state channels for  $\bar{N}N$  annihilation at rest. Note also that these rules should hold for nucleon-nucleon scattering, as well as for antiproton-proton annihilation

## 5 Comparison with the Experimental Data

As we now discuss, new experimental data on  $pp$ ,  $pn$  and  $\bar{p}p$  interactions provide valuable information that tends to verify many predictions of the polarized strangeness model.

### • Enhancement of $\phi$ production from spin-triplet states

The OBELIX collaboration has recently measured the  $\bar{p}p \rightarrow K^+K^-\pi^0$  channel for annihilation of stopped antiprotons in liquid, and in gas at NTP and at 5 mbar pressure [30]. These data enabled the branching ratios of the  $\bar{p}p \rightarrow \phi\pi^0$  channel to be determined for definite initial states:

$$Br(\bar{p}p \rightarrow \phi\pi^0, {}^3S_1) = (7.57 \pm 0.62) \cdot 10^{-4}, \quad (24)$$

$$Br(\bar{p}p \rightarrow \phi\pi^0, {}^1P_1) < 0.5 \cdot 10^{-4} \quad (25)$$

where the latter is a 95 % confidence-level upper limit. The indication of a strong dependence of the  $\phi\pi^0$  production rate on the quantum numbers of the initial  $\bar{p}p$  state, obtained earlier by the ASTERIX collaboration [24], has therefore been confirmed with statistics higher by a factor of 100. The branching ratio of the  $\phi\pi^0$  channel from the  ${}^3S_1$  initial state is at least 15 times larger than that from the  ${}^1P_1$  state. The polarized nucleon strangeness explains this remarkable selection rule, a feature not shared by other theoretical models.

It is important to note that the observed tendency exists only for  $\phi$  meson production, whereas P-wave  $\omega$  meson production is quite plentiful, as was observed in measurements of the antineutron-proton annihilation [32]. The cross section of the  $\bar{n}p \rightarrow \phi(\omega)\pi^+$  channel was measured for antineutron momenta in the range 50-405 MeV/c. It turns out that the  $\phi\pi^+$  cross section drops with energy in the same way as the S-wave. On the other hand, the  $\omega\pi^+$  cross section does not decrease so rapidly with energy. Moreover, a Dalitz-plot fit for the  $\omega\pi^+$  final state demands a significant P-wave contribution. The branching ratio of  $\omega\pi^+$  channel from the  ${}^3S_1$  final state is  $B.R.({}^3S_1) = (8.51 \pm 0.26 \pm 0.68) \cdot 10^{-4}$ , whereas that from the  ${}^1P_1$  final state is only three times less:  $B.R.({}^1P_1) = (3.11 \pm 0.10 \pm 0.25) \cdot 10^{-4}$ . This tendency is in sharp contrast with the same branching ratios for the  $\phi\pi$  final state (24)-(25). It was also found that the ratio  $R = Y(\phi\pi^+)/Y(\omega\pi^+)$  decreases with increasing

antineutron energy, as predicted by the polarized-strangeness model [15]. In this case, the energy dependence of  $\phi$  production should follow the energy dependence of the admixture of the  ${}^3S_1$  initial state, which declines from the  $\bar{n}p$  threshold. On the other hand, in the case of  $\omega$  production, both S- and P-wave amplitudes are possible and the P-wave admixture rapidly increases from the threshold, so we expect  $R = Y(\phi\pi^+)/Y(\omega\pi^+)$  to decrease with increasing antineutron energy.

Analogous differences in the angular distributions of  $\phi$  and  $\omega$  mesons produced in  $pp \rightarrow pp\phi(\omega)$  interactions were observed by the DISTO collaboration [33]. Whereas the  $\phi$  meson was found to be formed predominantly in an S-wave state relative to the  $pp$  system, the  $\omega$  angular distribution reveals contributions from higher partial waves. The measurements were done at a proton energy of 2.85 GeV, i.e., 83 MeV above the  $\phi$  production threshold, where it was found that

$$R_{pp} = \frac{\sigma(pp \rightarrow pp\phi)}{\sigma(pp \rightarrow pp\omega)} = (3.7 \pm 0.7_{-0.9}^{+1.2}) \cdot 10^{-3} \quad (26)$$

In this region, the correction due to the difference in  $\phi pp$  and  $\omega pp$  phase spaces is quite high, and the ratio (26) becomes a factor 10 larger than the OZI-rule prediction when corrected. Therefore, a substantial OZI violation has been observed also in the proton-proton interaction, and extracting the ratio from the S-wave only would lead to an even larger value of the  $\phi/\omega$  ratio. Since the S-wave spin-triplet initial state becomes diluted at higher energies above the threshold, one would expect that the deviation from the naïve OZI rule should increase further near threshold. <sup>3</sup>

#### • Enhancement of $f'_2(1525)$ production in spin-triplet annihilation states

Recent measurements of the  $\bar{p}p \rightarrow K^+K^-\pi^0$  channel at three hydrogen densities [30] provide the possibility of comparing the yields of the  $f'_2(1525)$  with that of the  $f_2(1270)$  meson, which consists of light quarks only, in both the

---

<sup>3</sup>Although the difference in the production mechanisms of the  $\phi$  and  $\omega$  mesons is obvious, it may not be a unique signal for intrinsic strangeness, since  $\phi$  meson production near threshold is anyway expected to be in the S-wave state. It is unclear whether 83 MeV above threshold is still the region of S-wave dominance. Experimental measurements of  $\phi$  and  $\omega$  production nearer threshold are badly needed.

S and P waves. It turns out that

$$R(f'_2(1525)\pi^0/f_2(1270)\pi^0) = (47 \pm 14) \cdot 10^{-3} \quad (\text{S-wave}) \quad (27)$$

$$= (149 \pm 20) \cdot 10^{-3} \quad (\text{P-wave}) \quad (28)$$

By comparison, on the basis of the naïve OZI rule one would expect that the ratio should be of the order of  $R(f'_2/f_2) = (3 - 16) \cdot 10^{-3}$ . The S-wave result (27) is consistent with the Crystal Barrel measurement [22]  $R(f'_2(1525)\pi^0/f_2(1270)\pi^0) = (26 \pm 10) \cdot 10^{-3}$  for annihilation in liquid hydrogen, where the S wave is dominant. We regard the excess of  $f'_2(1525)$  production (27) observed in the S-wave as marginal within the experimental errors. However, a strong apparent violation of the OZI rule is seen (28) for annihilation from the P-wave, as predicted by the polarized-strangeness model [15].

#### • Enhancement of $\bar{s}s$ pseudoscalars from spin-singlet states

The polarized-strangeness model predicts that the formation of an  $\bar{s}s$  system with  $J^{PC} = 0^{-+}$  should be enhanced from the spin-singlet states. However, some caution is needed when connecting this statement with the data on the production of real pseudoscalar mesons, due to their large departure from ideal mixing.

The OBELIX collaboration [34] recently measured  $\bar{p}p$  annihilation at rest into the  $\phi\eta$  final state for liquid hydrogen, and for gas at NTP and at a low pressure of 5 mbar. The  $\phi\eta$  final state has the same  $J^{PC}$  as the  $\phi\pi^0$  final state, so one might have expected to see the same selection rule as (24)-(25). However, the opposite trend is actually seen: the yield of the  $\bar{p}p \rightarrow \phi\eta$  channel grows with decreasing target density, and the corresponding branching ratios are

$$B.R.(\bar{p}p \rightarrow \phi\eta, {}^3S_1) = (0.76 \pm 0.31) \cdot 10^{-4} \quad (29)$$

$$B.R.(\bar{p}p \rightarrow \phi\eta, {}^1P_1) = (7.72 \pm 1.65) \cdot 10^{-4}, \quad (30)$$

another challenge for model interpretations.

Prediction of the rate of  $\phi\eta$  production is not straightforward in the framework of the polarized intrinsic-strangeness model. Since the  $\eta$  meson has a substantial  $\bar{s}s$  component, there is a contribution to the production of the

$\phi\eta$  final state via the production of two  $\bar{s}s$  pairs, one in the spin-triplet state and the other in the spin-singlet state. If one treats the reaction  $\bar{p}p \rightarrow \phi\eta$  as the formation of *pseudoscalar*  $\bar{s}s$  strangeonium, then the polarized intrinsic-strangeness model predicts that it should be formed from the *spin-singlet* initial state. It would be interesting to measure the density dependence of the  $\bar{p}p \rightarrow \omega\eta$  channel. So far, this yield was measured only for annihilation in liquid [22], and is quite high:  $Y(\omega\eta) = (1.51 \pm 0.12) \cdot 10^{-2}$ . If the arguments of the polarized strangeness model are valid for  $\eta$  production, then the yield of the  $Y(\omega\eta)$  final state from the  $^1P_1$  initial state should be higher than from the  $^3S_1$  initial state. However, no significant apparent OZI-violation for the *vector* meson ratio  $\phi\eta/\omega\eta$  is expected to occur even for annihilation from the  $^1P_1$  state.

It is interesting that similar strong enhancements of  $\eta$  production from initial spin-singlet states were observed in the reactions  $pp \rightarrow pp\eta$  and  $pn \rightarrow pn\eta$  [35]. An attempt to interpret this effect in the polarized strangeness model was made in [36]. There it was pointed out that, at threshold, the ratio between  $\eta$  production on neutron and on proton is:

$$R_\eta = \frac{\sigma(np \rightarrow np\eta)}{\sigma(pp \rightarrow pp\eta)} = \frac{1}{4} \left( 1 + \frac{|f_0|^2}{|f_1|^2} \right) \quad (31)$$

where  $f_1$  and  $f_0$  are the amplitudes corresponding to total isospin  $I = 1$  and  $I = 0$ , respectively. At threshold, when the orbital momentum of two nucleons in the final state is  $l_1 = 0$  and the orbital momentum of the produced meson relative to the center-of-mass system of these two nucleons also vanishes, the connection between the isospin and the total spin of the two nucleons in the initial state is fixed. The amplitude  $f_1$  corresponds to the spin-triplet initial nucleon state, and the amplitude  $f_0$  corresponds to the spin-singlet one. Therefore, using the experimental data on the  $pp$  and  $np$  cross sections, it is possible to estimate the ratio between spin-singlet and spin-triplet amplitudes. Recent measurements of  $\eta$  production in the threshold region [35] show that the ratio is fairly constant, with a value  $R_\eta \approx 6.5$ . According to (31), this means that, as was predicted by the polarized-strangeness model, the spin-singlet amplitude dominates  $|f_0|^2/|f_1|^2 \approx 25$ .

- **Shake-out of the  $\bar{s}s$  pair and open strangeness production**

Rearrangement diagrams like those in Fig. 1 lead to the production of  $\bar{s}s$



systems, but the shake-out of the  $\bar{s}s$  pair is also possible, via the diagrams shown in Figs. 2, 3.

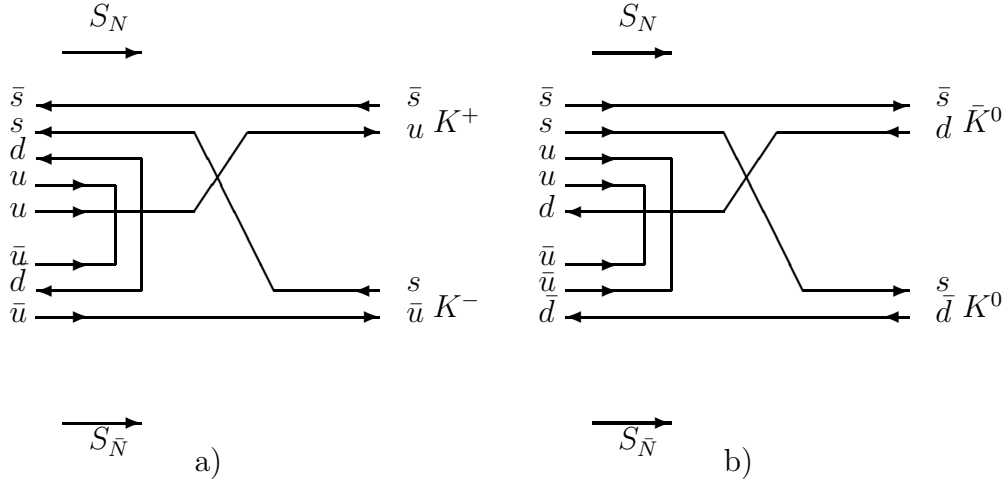

Figure 2: Production of  $K\bar{K}$  due to shake-out of a polarized  $\bar{s}s$  pair in the proton wave function in  $\bar{p}p$  annihilation from an initial  ${}^3S_1$  state, for (a) negative and (b) positive polarization of the  $\bar{s}s$  pair. The arrows show the directions of the spins of the nucleons and the quarks.

If the spins of the nucleon and antinucleon are oriented in the same direction, as, e.g., in the  ${}^3S_1$  initial state, the shake-out of *negatively* polarized  $\bar{s}s$  will form preferentially the *charged* pseudoscalar  $K^+K^-$  mesons from  $s$  and  $u$  quarks - which have opposite polarization - and *neutral* vector  $K^{*0}\bar{K}^{*0}$  mesons, from  $s$  and  $d$  quarks - which have the same polarization. The corresponding quark diagrams are shown in Fig. 2a and 3a. On the other hand, if the  $\bar{s}s$  quarks are polarized *positively*, i.e., along the direction of the nucleon spin, then  $s$  and  $u$  quarks will have the same polarization and they will form preferentially the *neutral* pseudoscalar  $K$  mesons and *charged* vector mesons  $K^*$ , as seen in Figs. 2b and 3b, respectively.

Therefore, shake-out of the negatively-polarized  $\bar{s}s$  pair from the  ${}^3S_1$  initial state should lead to the enrichment of charged  $K^+K^-$  pairs over  $K^0\bar{K}^0$

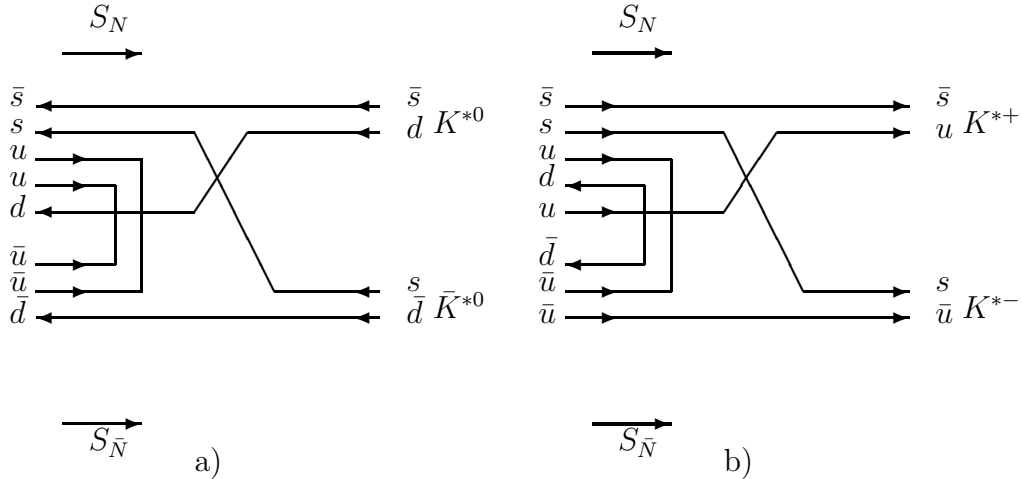

Figure 3: Production of  $K^* \bar{K}^*$  due to shake-out of a polarized  $\bar{s}s$  pair from the proton wave function in  $\bar{p}p$  interaction from an initial  ${}^3S_1$  state, for (a) negative and (b) positive polarization of the  $\bar{s}s$  pair. The arrows show the directions of the spins of the nucleons and the quarks.

ones and neutral  $K^{*0} \bar{K}^{*0}$  over  $K^{*+} K^{*-}$ . On the other hand, these effects should be absent for annihilation from the spin-singlet initial state  ${}^1S_0$ .

It has been known for a long time (see, e.g., [37]) that the yield of  $K^+ K^-$  pairs is indeed slightly higher than that of  $K^0 \bar{K}^0$  pairs for annihilation in liquid, where the  ${}^3S_1$  state dominates:

$$Y(K^+ K^-) = (10.8 \pm 0.5) \cdot 10^{-4} \quad (32)$$

$$Y(K^0 \bar{K}^0) = (8.3 \pm 0.5) \cdot 10^{-4} \quad (33)$$

When combined with the large yield from the pure isospin  $I = 1$  state reaction  $\bar{p}n \rightarrow K^- K^0$  [38]:

$$Y(K^- K^0) = (14.7 \pm 2.1) \cdot 10^{-4} \quad (34)$$

these data reveal a striking hierarchy between the isospin amplitudes  $T_0, T_1$  for  $K \bar{K}$  production from the isospin  $I=0$  and  $I=1$  states:

$$T_1(K \bar{K})/T_0(K \bar{K}) \simeq 5 - 10 \quad (35)$$

This dynamical selection rule is well-known [39], and the dominance of the isospin  $I=1$  amplitude is usually considered to be due to an initial-state

interaction due to an admixture of the pure isospin  $I=1$   $\bar{n}n$  state in the  $\bar{p}p$  wave function [40, 41]. The polarized intrinsic-strangeness model provides an alternative explanation of the facts (32)-(34), and demonstrates that this selection rule may have the same origin as the preferential production of vector  $K^{*0}\bar{K}^{*0}$  mesons over  $K^{*+}K^{*-}$ .

This phenomenon has indeed been observed in bubble-chamber experiments [42, 43], where it was found that annihilation into two neutral  $K^*$  dominates over charged  $K^*$  formation. For instance, according to [42],  $Y(\bar{p}p \rightarrow K^{*0}\bar{K}^{*0}) = (30 \pm 7) \cdot 10^{-4}$ , whereas  $Y(\bar{p}p \rightarrow K^{*+}\bar{K}^{*-}) = (15 \pm 6) \cdot 10^{-4}$ .

This tendency has recently been confirmed by the Crystal Barrel collaboration [44] in measurements of the channel  $\bar{p}p \rightarrow K_L^0 K^\pm \pi^\mp \pi^0$  in annihilation at rest. It was found that, for annihilation from the  $^3S_1$  state, the ratio between neutral and charged  $K^*$  production is

$$\frac{K^*(neutral)\bar{K}^*(neutral)}{K^*(charged)\bar{K}^*(charged)} \approx 3 \quad (36)$$

We are not aware of other theoretical arguments that explain this unexpected selection rule. On the other hand, the polarized-strangeness model provides a natural explanation of this effect, making essential use of the sign of polarized pair. In remarkable consistency with this hypothesis, this effect is absent for annihilation from the  $^1S_0$  initial state, again as it should be for shake-out of a polarized  $\bar{s}s$  pair.

#### • Momentum transfer dependence of the OZI rule violation

It was conjectured [15] that the degree of OZI rule violation might depend on the momentum transfer. An answer to this question is provided by the data obtained by the OBELIX collaboration on the reaction  $\bar{p} + p \rightarrow \phi + \pi^+ + \pi^-$ , which was compared with the similar  $\omega$  production reaction [45]. The ratio  $R = Y(\phi\pi^+\pi^-)/Y(\omega\pi^+\pi^-)$  for the annihilation of stopped antiprotons in a gaseous and a liquid hydrogen target was measured as a function of the invariant mass of the dipion system. If one sums over all events, without any selection on the dipion mass, the ratio  $R$  is at the level of  $(5 - 6) \cdot 10^{-3}$ , i.e., in agreement with the simple prediction of the OZI rule. However, at small dipion masses  $300 \text{ MeV} < M_{\pi\pi} < 500 \text{ MeV}$ , the degree of OZI rule violation increases to  $R = (16 - 30) \cdot 10^{-3}$ . This should be compared with the ratio  $R = (106 \pm 12) \cdot 10^{-3}$  for the  $\phi\pi^0/\omega\pi^0$  channel for annihilation in liquid [22],

which proceeds from the same  ${}^3S_1$  initial state. Thus, it indeed turns out that, in  $\phi$  production from the  ${}^3S_1$  initial state, the degree of OZI-rule violation increases as the mass of the system created in association with the  $\phi$  decreases, i.e., as the momentum transfer increases. It would be interesting to perform a systematic investigation of the extent to which the degree of the apparent OZI-rule violation depends on the momentum transfer.

### • Predictions for $\Lambda$ production

It is straightforward to extend the polarized-strangeness model to the formation of  $\bar{\Lambda}\Lambda$  and  $\phi\phi$  systems. The PS 185 experiment [46] observes a remarkable suppression of the spin-singlet fraction  $F_s$  in the  $\Lambda\bar{\Lambda}$  final state:  $F_s = 0.00014 \pm 0.00735$ . This is in agreement with the polarized-strangeness model expectations, which were analysed in [16]. If the  $\bar{s}s$  quarks are polarized in the initial state, it is natural to expect that they will keep the total spin  $S = 1$  in the final state and the spin-singlet fraction should be quite small.

The PS 185 collaboration has also measured the  $\bar{p}p \rightarrow \Lambda\bar{\Lambda}$  channel in annihilation on a polarized target, to evaluate the target spin depolarization  $D_{nn}$ . The polarized-strangeness model predicts [16] that  $D_{nn}$  should be negative.

This prediction also holds for  $\Lambda$  production in polarized proton-proton interactions. Remarkably, the recent results of the DISTO collaboration [47] confirm this prediction. The spin-transfer coefficient  $D_{nn}$  has been measured for the exclusive reaction  $\bar{p}p \rightarrow \Lambda K^+ p$  of a polarized proton of 3.67 GeV/c on an unpolarized proton target. It was found that, for positive momentum fractions for the  $\Lambda$ ,  $x_F > 0$ ,  $D_{nn} \approx -0.4$  is large and negative. The value of  $D_{nn}$  reflects the fraction of the normal beam polarization transferred to the hyperon. The negative sign of  $D_{nn}$  means that the component of the  $\Lambda$  polarization that is correlated with the beam spin is oriented opposite to the beam spin. As discussed in Section 4, it is clear that such a correlation is a consequence of the negative polarization of the strange quarks in the nucleon.

### • Predictions for $\bar{p}p \rightarrow \phi\phi$

The JETSET collaboration has seen an unusually high apparent violation of the OZI rule in the reaction  $\bar{p} + p \rightarrow \phi + \phi$  [48, 49]. The measured cross

section of this reaction turns out to be 2-4  $\mu\text{b}$  for momenta of incoming antiprotons from 1.1 to 2.0 GeV/c. This is two orders of magnitude higher than the value of 10 nb expected from simple application of the OZI rule. If this apparent OZI violation is due to the presence of polarized strangeness in the nucleon, then it was predicted [15] that the  $\phi\phi$  system should be produced mainly from the initial spin-triplet state. Recent data from the JETSET collaboration [48] indeed demonstrate that  $\phi\phi$  production is dominated by the initial spin-triplet state with  $2^{++}$ . Moreover, a preliminary analysis [50] shows that final states with total spin  $S = 2$  for the  $\phi\phi$  system are enhanced. This fact is explained naturally in the polarized-strangeness model, on the basis of the same arguments as spin-triplet dominance of the  $\Lambda\bar{\Lambda}$  system created in  $\bar{p}p$  annihilation [16].

## 6 Other Approaches

As we have seen, up to now there are no experimental facts which could be used to rule out the intrinsic polarized-strangeness model, and its many successes give credence to the approach and stimulate further investigations, which we discuss in the next Section. However, first we discuss in this Section the extent to which other models could explain the experimental facts discussed in the previous Section.

The polarized nucleon strangeness is not the only possible explanation of each of the experimental facts discussed. For example, in case of  $\phi\phi$  production, the ‘simplest’ hypothesis explaining  $2^{++}$  dominance is the presence of a tensor glueball. The absence of the spin-singlet state in the  $\Lambda\bar{\Lambda}$  system could be reproduced in meson-exchange models [51]. Clearly, these explanations do not correlate the two sets of data, as does the polarized-strangeness model.

Of more interest, it has been suggested that the anomalously high yield of the  $\bar{p}p \rightarrow \phi\pi^0$  channel could be explained [13, 14, 52] by rescattering diagrams with OZI-allowed transitions in the intermediate state, e.g.,  $\bar{p}p \rightarrow K^*\bar{K} \rightarrow \phi\pi^0$ . Calculations are capable [13, 14, 52] of reasonable agreement with the experimental data on the  $\phi\pi$  yield for annihilation from the S-wave. However, what is not yet explained in this approach is the strong dependence of the  $\phi$  yield on the spin of the initial state. In fact, it is unclear, in any conventional approach which does not assume polarized intrinsic strangeness in the nucleon, why the  $\phi\pi$  yield for annihilation from the S-wave is so strong,

but is absent from the P-wave.

Moreover, strong cancellations are expected between different hadronic loop amplitudes [18, 53, 54]. Indeed, it has been argued [18] that just this feature is the explanation of the approximate validity of the OZI rule. Selection of only one type of intermediate state, such as  $K^*K$  or  $\rho\pi$ , spoils this delicate cancellation in an uncontrolled way. The importance of using a *complete* set of OZI-allowed hadronic loops for the calculations of different nucleon strangeness characteristics has recently been demonstrated in [54].

Finally, data from the OBELIX collaboration [30, 32] demonstrate that  $\phi$  production is uncorrelated with the  $K^*K$  channel. The annihilation yield of the  $K^*\bar{K}$  final state in antiproton annihilation at rest have been determined [30] at different target densities. It turns out that the  $^1P_1$  fraction of the  $K^*\bar{K}$  annihilation yield is not negligible, as one would expect in two-step rescattering models. It is comparable with the  $^3S_1$  fraction, and *increases* as the target density decreases. This dependence is opposite to that of the  $\phi\pi$  yield, which decreases with the target density.

The annihilation of antineutrons in flight also exhibits different patterns for the  $\phi\pi$  and the  $K^*\bar{K}$  final states [32]. Whereas the  $\phi\pi$  cross section decreases strongly with increasing antineutron energy, the  $K^*\bar{K}$  cross section remains essentially flat within the measured energy interval.

Also inexplicable in the rescattering mechanisms is the copious production of tensor strangeonium from the P-wave. The production of  $f'_2$  in the reaction  $\bar{p}p \rightarrow f'_2\pi^0$  was calculated in [55] via final-state interactions of  $K^*K$  and  $\rho\pi$ . The production yield of  $f'_2$  so obtained is rather small, about  $10^{-6}$ , which is about two orders of magnitude less than the values (27)-(28) measured by the OBELIX collaboration [30].

An attempt to calculate the  $\phi$  yields in  $\bar{p}p$  annihilation at rest in a non-relativistic quark model with a  $\bar{s}s$  admixture in the nucleon wave function was made in [58]. There it was assumed that the  $\phi$  is produced by shake-out of the nucleon  $\bar{s}s$  component, which implied that the quantum numbers of the  $\bar{s}s$  pair in the nucleon had to be  $J^{PC} = 1^{--}$ , as opposed to our  $^3P_0$  proposal. The branching ratios calculated for the  $\phi\eta$  channel were  $B.R.(^3S_1 \rightarrow \phi\eta) = (1.4 - 1.8) \cdot 10^{-4}$  and  $B.R.(^1P_1 \rightarrow \phi\eta) = (0.15 - 0.2) \cdot 10^{-4}$ . Therefore, this particular shake-out mechanism predicts the  $\phi\eta$  yield from the P-wave should be ten times less than from the S-wave, whereas experiment observed exactly the opposite, namely that the P-wave branching ratio is ten times higher than the S-wave one: see (29)-(30).

An interesting possibility considered in [57] is that the final-state interaction (FSI) of two kaons could enhance  $\phi$  production. Indeed, for annihilation at rest, the phase-space volume in a  $\bar{K}KX$  final state is limited, the two kaons are created with low relative momenta, and they could, in principle, fuse into  $\phi$  due via FSI. However, this model does not explain why the FSI effects are stronger for annihilation from the P-wave than from the S-wave.

It was suggested in [56] that the suppression of the  $\phi\pi$  yield from the  $^1P_1$  state might be connected with some peculiarity of the protonium atom which leads to an abnormally low probability to populate this  $^1P_1$  level. However, if this atomic-physics effect existed, one would expect to observe the same suppression of the  $\phi\eta$  channel from  $^1P_1$  state. However, this is contrary to the previously-mentioned experimental results of [34], where *enhancement* of the  $\phi\eta$  channel was observed in annihilation from the  $^1P_1$  state.

It seems that approaches based on traditional ideas [13, 14, 58] are unable to reproduce all the features of  $\phi$  production and related phenomena observed so far. On the other hand, the polarized intrinsic-strangeness model [15] not only provides a transparent physical explanation of the spin effects observed in the production of  $\phi$ ,  $f'_2(1525)$ ,  $\eta$  and  $K^*$  mesons, as well as  $\Lambda$  baryons, but predicts some definite tests. Some of these have already been confirmed, as discussed in the previous Section, and others we discuss in the following Section.

## 7 New Tests and Predictions

The polarized-strangeness model has successfully passed through a number of experimental tests, which gives credence to the new predictions discussed below. We propose two general classes of tests - to verify the mechanism of strangeness shake-out, and to search for the correlations due to the negative polarization of the intrinsic nucleon strangeness.

### • $\bar{K}K$ production at low energies

One example how to test the strangeness shake-out mechanism is to study  $\bar{K}K$  production at low energies. According to our model, the  $\bar{s}s$  pair in the nucleon has preferentially the quantum numbers  $J^{PC} = 0^{++}$ . The shake-out of the pair from the nucleon therefore results in the formation of a  $K\bar{K}$  pair

with  $J^{PC} = 0^{++}$  quantum numbers, which should be preserved by final-state interactions. This conjecture can be tested, not only in a partial-wave analysis of  $\bar{K}K$  system, but also directly by comparing the relative yields of  $K_S K_L$  and  $K^+ K^-$  pairs created in the hadronic interaction. The negative C-parity of the  $K_S K_L$  system prevents its formation via shake-out processes: it should be created in the less probable reaction of rearrangement.

To illustrate this point, let us consider  $\bar{p}p$  annihilation at rest into the  $\bar{K}K\pi$  channel. One may expect that

$$Y(K^+ K^- \pi^0) = 2 \cdot Y(K_S K_L \pi^0), \quad (37)$$

where we denote by  $Y$  the yields of the corresponding channels. For annihilation in liquid hydrogen, it was found [30] that  $Y(K^+ K^- \pi^0) = (23.7 \pm 1.6) \cdot 10^{-4}$ , whereas the yield of the  $K_S K_L \pi^0$  system is [22]  $Y(K_S K_L \pi^0) = (6.7 \pm 0.7) \cdot 10^{-4}$ . However, these data refer to the annihilation frequencies of inclusive  $K\bar{K}\pi$  channels, where also reactions proceeding via heavy-meson formation, i.e.,  $\bar{p}p \rightarrow \pi M (M \rightarrow K\bar{K}) \rightarrow \pi K\bar{K}$  leading to the same combination of strange and non-strange mesons contribute. More data on the exclusive non-resonant  $K\bar{K}\pi$  channel are desirable.

As typical examples of experiments to test the correlations due to polarization of the strange quarks, we propose the following.

•  **$\phi$  production in the interactions of polarized protons with polarized deuterons**

It was predicted [15] that  $\phi$  production in polarized-proton interactions with polarized deuterons:

$$\vec{p} + \vec{d} \longrightarrow {}^3He + \phi, \quad (38)$$

would be enhanced when the spins of the proton and deuteron are parallel. Measurements of the  $\phi$  (and  $\omega$ ) yields in the reaction (38) were performed at Saturne II using an unpolarized beam and target configuration [59], and a large deviation from the OZI rule prediction was revealed:

$$R(\phi/\omega) = (80 \pm 3_{-4}^{+10}) \cdot 10^{-3} \quad (39)$$



This result is promising for future studies of the sensitivity to polarization of the OZI rule violation in this process. The main physical advantage of studying the reactions (38), with  ${}^3He$  production, is that they offer the possibility to studying OZI rule violation in the high-momentum-transfer region.

It is remarkable that the standard two-step model of  ${}^3He$  production in reaction (38) predicts a completely different behaviour. It was calculated [60] that, if the vector mesons are created via the chain  $pp \rightarrow d\pi^+$ ,  $\pi^+n \rightarrow \phi p$  and  $dp \rightarrow {}^3He$ , then they should be produced mainly from the antiparallel orientation of the proton and deuteron spins. The predicted value for the asymmetry

$$A = \frac{Y(\uparrow\uparrow) - Y(\uparrow\downarrow)}{Y(\uparrow\uparrow) + Y(\uparrow\downarrow)}, \quad (40)$$

where  $Y$  is the yield of  ${}^3He$  for the parallel and anti-parallel orientations of the spins of protons and deuterons, is  $A = -0.95$  near threshold. The polarized intrinsic-strangeness model predicts that  $A \approx +1$ .

#### • Tests in nucleon-nucleon interactions

It is important to verify if the selection rules found in the antiproton annihilation at rest have counterparts for nucleon-nucleon or electron-nucleon interactions. It is planned at the ANKE spectrometer at COSY [61] to measure  $\phi$  production in polarized proton interactions with a polarized proton target:

$$\vec{p} + \vec{p} \rightarrow p + p + \phi \quad (41)$$

If  $\phi$  production in the nucleon-nucleon interaction is dominated by the spin-triplet amplitude, as was observed in antiproton annihilation then  $\phi$  production should be maximal when the beam and target nucleons have parallel polarizations, and suppressed when they are antiparallel.

#### • Spin dependence of the $\phi$ production by unpolarized nucleons

It is possible to verify the spin dependence of the  $\phi$  production amplitude using unpolarized nucleons:  $\phi$  production in  $np$  and  $pp$  collisions at threshold should also follow (31). If  $\phi$  is not produced from spin-singlet states, then

the ratio of the  $np$  and  $pp$  cross sections at threshold is

$$R_\phi = \frac{\sigma(np \rightarrow np\phi)}{\sigma(pp \rightarrow pp\phi)} = \frac{1}{4} \left( 1 + \frac{|f_0|^2}{|f_1|^2} \right) \approx \frac{1}{4} \quad (42)$$

This ratio was recently calculated [62] in the framework of a one-boson exchange model, i.e., without any assumption about the nucleon's intrinsic strangeness, with the prediction  $R_\phi = 5$ . Therefore, experimental measurements of this ratio near threshold could discriminate between the predictions of these theoretical models.

- **Negative  $\Lambda$  polarization in target fragmentation**

The polarized-strangeness model predicts [17] that  $\Lambda$  hyperons created in the target fragmentation region of deep-inelastic scattering should have large negative longitudinal polarization. It will be possible to verify this prediction soon in the NOMAD (CERN) and HERMES (DESY) experiments. Also the COMPASS experiment at CERN expects [63] to study  $\Lambda$  polarization with large statistics, namely of the order of  $10^5$   $\Lambda$  decays.

## 8 Conclusions

We have presented in this paper an update on polarized intrinsic strangeness in the nucleon wave function. We have presented the latest status of data from LEAR and other experiments bearing, in particular, on large apparent violations of the naïve OZI rule. We have refined and developed a model of the  $\bar{s}s$  component of the nucleon wave function, and applied it to the production of various  $\bar{s}s$  quarkonium systems, such as the  $\phi$  and  $f'_2(1525)$  mesons. We have shown that this model describes successfully many aspects of  $p\bar{p}$  annihilation into final states containing these mesons, as well as other processes involving the production of these mesons,  $K$  and  $K^*$  mesons, and  $\Lambda$  baryons. We pointed out the natural connection between our physical picture and the interpretation of the polarized deep-inelastic scattering data. We have also contrasted the predictions of the polarized intrinsic-strangeness model with alternative interpretations of the LEAR and related data. Finally, we have enumerated several new predictions and tests of this model.

It is clearly desirable to put the polarized intrinsic-strangeness model on a more solid theoretical basis. Two-dimensional QCD has already been shown to support the idea that hadronic wave functions contain  $\bar{s}s$  pairs [64], but this model is not able to cast significant light on their possible polarization. Some qualitative non-perturbative calculations have been proposed in four dimensions (see, e.g., [28]), but these have yet to become very quantitative. On the experimental front, the LEAR accelerator has now been closed. Although interesting analyses of data obtained there are continuing, the experimental emphasis is necessarily shifting elsewhere. Fortunately, as we have emphasized in the previous section, there are several interesting experimental tests that can be made with low-energy proton accelerators and in deep-inelastic scattering experiments. We are optimistic that they may bring our understanding of the strange nucleon wave function to a new level.

## Acknowledgments

The research of one of us (M.K.) was supported in part by a grant from the United States-Israel Binational Science Foundation (BSF), Jerusalem, Israel, and by the Basic Research Foundation administered by the Israel Academy of Sciences and Humanities. D.K. thanks RIKEN, Brookhaven National Laboratory, and the U.S. Department of Energy for providing the facilities essential for the completion of this work.

## References

- [1] B.L. Ioffe, Nucl.Phys. B188 (1981) 317 [Erratum:B191 (1981) 591].
- [2] J. Gasser, H. Leutwyler and M.E. Sainio, Phys.Lett. B253 (1991) 252; 260.
- [3] NuTeV collaboration, T. Adams et al., hep-ex/9906038, and V. Barone, C. Pascaud and F. Zomer, *A new global analysis of deep inelastic scattering data*, hep-ph/9907512, and references therein.
- [4] M. Duren, *Summary of the experimental spin sessions at DIS 99*, hep-ex/9905053, and references therein.
- [5] S.J. Brodsky, J. Ellis and M. Karliner, Phys.Lett. B206 (1988) 309.
- [6] A.V. Efremov and O.V. Teryaev, JINR-E2-88-287.
- [7] G. Altarelli and G.G. Ross, Phys.Lett. B212 (1988) 391;
- [8] R.D. Carlitz, J.C. Collins and A.H. Mueller, Phys.Lett. B214 (1988) 229.
- [9] W. Vogelsang, *Summary of the theory talks on spin physics at DIS 99*, hep-ph/9906289, and references therein.
- [10] S. Okubo, Phys.Lett. B5 (1963) 165; G. Zweig, CERN Report 8419/TH412 (1964); I. Iizuka, Prog. Theor. Phys. Suppl. 37-38 (1966) 21.
- [11] J. Ellis, E. Gabathuler and M. Karliner, Phys.Lett. B217 (1989) 173.

- [12] C.B. Dover and P.M. Fishbane, *Phys.Rev.Lett.* 64 (1989) 2917.
- [13] M.P. Locher, Y. Lu and B-S. Zou, *Z.Phys.* A347 (1994) 281; M.P. Locher and Y. Lu, *Z.Phys.* A351 (1995) 83.
- [14] D. Buzatu and F. Lev, *Phys.Lett.* B329 (1994) 143.
- [15] J. Ellis, M. Karliner, D.E. Kharzeev and M.G. Sapozhnikov, *Phys.Lett.* B353 (1995) 319.
- [16] M. Alberg, J. Ellis and D.E. Kharzeev, *Phys.Lett.* B356 (1995) 113.
- [17] J. Ellis, D.E. Kharzeev and A. Kotzinian, *Z.Physik* C69 (1996) 467.
- [18] H.J. Lipkin, Weizmann Institute preprint WIS-91/79 (1991), and *Int.J.Mod.Phys.* E1 (1992) 603.
- [19] S. Okubo, *Phys.Rev.* 16 (1977) 2336.
- [20] V.P. Nomokonov, Ph.D. thesis, 1999, JINR, Dubna.
- [21] M.G. Sapozhnikov, JINR preprint E15-95-544, Dubna, 1995; Lecture at the XXIX St. Petersburg Winter School on Nuclear Physics and Elementary Particles, Zelenogorsk, 1995, p.252.
- [22] C.Amsler, *Rev.Mod.Phys.* 70 (1998) 1293.
- [23] V.G. Ableev et al., *Nucl.Phys.* A594 (1995) 375.
- [24] J.Reifenrother et al., *Phys.Lett.* B267 (1991) 299.
- [25] B.L. Ioffe and M. Karliner, *Phys.Lett.* B247 (1990) 387.
- [26] C.B. Dover and P.M. Fishbane, *Phys.Rev.Lett.* 64 (1990) 3115.
- [27] S. Forte and E.V. Shuryak, *Nucl.Phys.* B357 (1991) 153.
- [28] N.I.Kochelev, *Phys.Rev.* D57 (1998) 5539.
- [29] Review of Particle Properties, *Eur.Phys.J.* C3 (1998) 1.
- [30] The OBELIX collaboration, A. Alberico et al., *Phys.Lett.* B438 (1998) 430.

- [31] The OBELIX collaboration, R. Doná, Proc. LEAP'98 Conference, Villasimius, 1998.
- [32] The OBELIX collaboration, A. Filippi et al., Nucl.Phys., A655 (1999) 453.
- [33] F. Balestra et al., Phys.Rev.Lett. 81 (1998) 4572.
- [34] The OBELIX collaboration, A. Alberico et al., Phys.Lett. B432 (1998) 427.
- [35] H. Calen et al., Phys.Rev. C58 (1998) 2667.
- [36] M. Rekaló, J. Arvieux and E. Tomasi-Gustafsson, Phys. Rev. C55 (1997) 2630.
- [37] The ASTERIX collaboration, M.Doser et al., Phys. Lett., B215 (1988) 792.
- [38] A.Bettini et al., Nuov.Cim., A62 (1969) 1038.
- [39] A. Rotondi, Nucl.Phys., A558 (1993) 235c.
- [40] J. Carbonell, G.Ihle and J.M.Richard, Z.Phys. A335 (1989) 329.
- [41] J. Jacnicke, B.Kerbikov and H.-J.Pirner, Z.Phys. A339 (1991) 297.
- [42] N.Barash et al., Phys.Rev., 139B (1965) 1659.
- [43] C.Baltay et al., Phys.Rev. Lett., 15 (1965) 532.
- [44] The Crystal Barrel collaboration, A. Abele et al., Phys.Lett. B415 (1997) 289.
- [45] A. Bertin et al., Phys.Lett. B388 (1996) 450.
- [46] The PS 185 collaboration, T. Johansson, Proc. LEAP'98 Conference, Villasimius, 1998.
- [47] F. Balestra et al., nucl-ex/9906011.
- [48] M. Lo Vetere et al., Nucl.Phys. B(Proc.Suppl.) 56A (1997) 256.

- [49] The JETSET collaboration, C. Evangelista et al., Phys.Rev. D57 (1998) 5370.
- [50] The JETSET collaboration, L.Bertolotto et al., Yad.Fiz. 59 (1996) 1501.
- [51] J. Haidenbauer et al., Phys.Rev. C46 (1992) 2158.
- [52] O. Gortchakov et al., Z.Phys. A353 (1996) 447.
- [53] P.Geiger and N.Isgur, Phys.Rev.Lett., 67 (1991) 1066.
- [54] P.Geiger and N.Isgur, Phys.Rev., D55 (1997) 299.
- [55] D. Buzatu and F. Lev, Phys.Lett. B 359 (1995) 393.
- [56] B.S. Zou, Proc. NAN'95 Conference, Moscow, 1995.
- [57] V.E. Markushin and M.P. Locher, Eur.Phys.J. A1 (1998) 91.
- [58] T. Gutsche, A. Faessler, G.D. Yen and S.N. Yang, Nucl.Phys.B (Proc.Suppl.) 56A (1997) 311.
- [59] R. Wurzinger et al., Phys.Lett. B374 (1996) 283.
- [60] L.A. Kondratyuk and Yu.N. Uzikov, Yad.Fiz. 60 (1997) 542.
- [61] The ANKE collaboration, COSY Letter of Intent number 35 (1995).
- [62] A.I. Titov, B. Kampfer and V.V. Shklyar, Phys.Rev. C59 (1999) 999.
- [63] The COMPASS collaboration, G. Baum et al., CERN/SPSLC 96-14 (1996).
- [64] J. Ellis, Y. Frishman, A. Hanany and M. Karliner, Nucl.Phys. B382 (1992) 189.