

CONVENTIONAL MAGNETS – II

Neil Marks.

Daresbury Laboratory, Warrington, U.K.

Abstract

This second paper covers the wide range of techniques associated with a.c. and pulsed magnets and associated power supplies. The necessary changes in magnet design to minimise eddy losses in low frequency magnets are first considered and this leads to a broader discussion of the different types of steel used in magnet yokes. Inductance is then considered and the traditional power supply circuit used for a.c. magnets is described. The paper then presents a simple description of the higher frequency pulsed magnets and supply circuits used for injection and extraction and contrasts a number of different design concepts for both kicker and septum systems. In conclusion, the relevant properties of high frequency magnetic materials are briefly reviewed.

1. INTRODUCTION TO AC EFFECTS

The paper resulting from the first seminar dealt exclusively with the design of accelerator magnets generating d.c. or what was referred to as 'slowly varying' fields. This second paper will mainly concentrate on magnet systems with time varying fields and will separately discuss 'low-frequency' and pulsed or 'higher-frequency' devices. It is therefore useful to give some definition to further clarify the arbitrary distinction between these three separate classifications, as used in this paper.

A convenient, though not rigorous, criterion relates to eddy current effects. These are the currents that are induced in any conducting material by the emf generated by a rate of change of magnetic flux cutting the material, as given by the Maxwell equation for electromagnetic induction:

$$\text{curl } \mathbf{E} = -d\mathbf{B}/dt$$

The **d.c.** or **slowly varying magnet** can therefore be regarded as one in which eddy currents have a negligible effect on the performance of the magnet and its power losses. It will be seen that this definition includes laminated magnets with excitations having Fourier components extending from d.c. to one or two Hertz. It should be noted, however, that if solid steel is used in the yoke, eddy effects are produced by very much lower frequency fields, oscillating at 0.1 Hertz or less. The first seminar was devoted to d.c. systems, though much of the physics was quite general.

In a **low-frequency magnet**, the eddy currents will increase, perhaps appreciably, the power losses in the coil. However, their potential for influencing the magnetic field distribution

can be largely nullified by the standard power frequency design criteria. Consequently, there will be no significant modification to the d.c. field distribution and magnetostatic codes can be reliably used. The magnet design can therefore be based on standard d.c. magnet criteria, but with some design modifications, particularly to the coil and ends, to prevent excess eddy currents. Such magnets would use the standard techniques that are used for distribution transformers in the electrical engineering industry. This somewhat arbitrary definition includes magnets operating from a few Hertz up to several hundred Hertz.

Pulsed or higher-frequency magnets can then be regarded as devices with waveform components at or above 1 kHz; however, it is not the intention of this paper to consider radio frequency effects, so the upper limit will be pulsed magnets with switching times of the order of 0.1 μ s. In such magnets, induced a.c. effects will dominate and will result in the necessity for radical alterations in the design of the unit and its power supply. The dynamic effects may also produce major changes to the field distribution which, in one particular case, can be used to produce certain desirable results.

The first part of this paper considers low frequency magnets used as the main bending and focusing elements in a synchrotron. The later section, dealing with pulsed and higher-frequency devices, is more relevant to switching magnets used for injection and extraction systems.

2. LOW FREQUENCY SYSTEMS

2.1 Eddy Current Losses

The power losses associated with eddy currents in conductors with simple geometries in externally imposed oscillating fields are given in Box 1. These are simply obtained by taking the eddy loss in a small element and integrating over the conductor cross section. The magnet designer using the simple two-dimensional magneto-static codes discussed in the first paper can, therefore, assess the expected eddy loss in a given coil design by examining the distribution of flux density predicted by the code at the coil position and then summing the loss calculated for each turn.

This calculation assumes that the eddy currents will not appreciably influence the flux distribution predicted by the

Rectangular conductor (no cooling hole):

resistivity ρ ;
width a ;
cross section A ;

in a.c. field: $B \sin \omega t$;

Power loss/m is:

$$P = \omega^2 B^2 A a^2 / (12 \rho)$$

Circular conductor, diameter d :

$$P = \omega^2 B^2 A d^2 / (16 \rho)$$

eg 10 mm square copper
in a 1T peak, 50 Hz a.c. field,

$$P = 3.4 \text{ kW/m.}$$

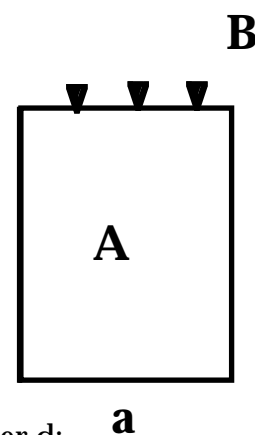

Box 1: Eddy losses in Conductors.

magneto-static code, a feature of the definition of 'low frequency' given above. The validity of this assumption can then be tested from the result. In an economically viable design, the eddy loss should be much less than the d.c. ohmic loss in the coil and this condition also indicates that the modification in the flux passing through the coil by the eddy currents will be negligible. It should be appreciated that the small changes to the field distribution that will occur will result in some reduction of the field cutting the coil conductor; hence the losses predicted using the above technique will be slightly pessimistic. A number of the more advanced codes now include magneto-dynamic calculations and hence predict the eddy effects for a given frequency of field. These codes will solve the differential equations, so that the eddy current influence on the field distribution is predicted along with the loss, thus giving a more accurate result and saving the tedious work of numerically summing the losses over the coil.

2.2 Design Changes to Limit Eddy Losses in Coils

It can be seen from Box 1 that the loss per unit length of conductor is proportional to the conductor's cross sectional area and, additionally, to the square of the conductor width presented to the field (the dimension *a* in the diagram). Hence, the widths of solid conductor in a coil and the steel laminations in the yoke have a very major influence on the eddy losses in an a.c. magnet. The numerical example given in Box 1 shows that the eddy current loss in a 100 mm² cross section copper conductor in a 1T peak, 50 Hz a.c. field is of the order of 3 kW/m. This is a very appreciable loss, indicating that it would be impractical to design a 50Hz magnet with solid copper coils of such large cross section.

The eddy losses vary as the square of the frequency, so standard solid conductor, with an internal cooling hole, can be used up to about 10Hz. Even at this frequency, the conductor cross section must be kept small. If large cross sections are required, separate small conductors must be wound together within the coil and connected in parallel to provide the necessary cross section area. These conductors must be individually insulated and then transposed through the coil. This standard electrical engineering technique, illustrated in Box 2, ensures that the multiple conducting paths through the coil couple approximately the same total flux. Without this provision, there would be different magnitudes of alternating current in each separate conductor and as the ohmic loss varies as the square of the current, this results in higher total losses. The alternative model is to regard the main excitation current as identical in each conductor path, with a superimposed

circulating current that produces further losses; either approach gives the same total loss. In a compact coil design, transposition between turns, as shown in Box 2, is difficult and it is more usual to use different layers or 'pancakes' in the complete coil assembly. The separate conductors are then transposed between pancakes to equalise the flux linkage on each path.

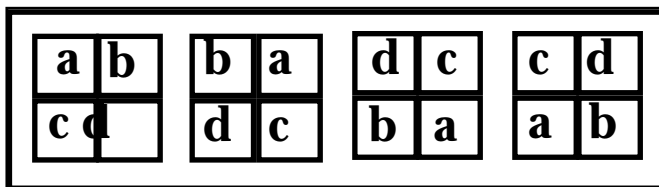

Standard transposition to avoid excessive eddy loss; The conductors a, b, c, and d making up one turn are transposed into different positions on subsequent turns in a coil to equalise flux linkage.

Box 2: Transposition of conductors.

For operating frequencies significantly above 10Hz, it is generally necessary to use stranded cable. This is fabricated from thin strands of conductor with diameters of the order of 1mm; each strand is separately insulated. These are twisted along the length of the cable during manufacture, so that transposition occurs. A number of manufacturers now supply such cable with a rectangular cross section.

In Box 3, the cross section of a single turn in a coil designed to conduct approximately 1000 A rms at 50 Hz and used in the old 4 GeV synchrotron NINA at Daresbury Laboratory, is shown. Four separately insulated stranded cables are externally transposed to limit circulating currents.

The stranded conductor presents cooling problems, as a central cooling tube cannot be used. In the example shown, a thin-walled 'indirect' water cooling circuit has been introduced to dissipate the conductor losses. It will be seen that at 50 Hz and above, the construction of coils for a.c. magnets becomes complex and correspondingly expensive.

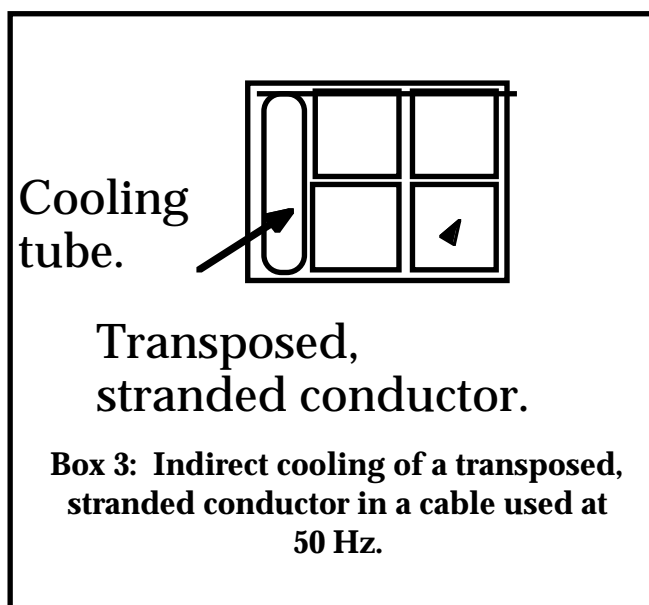

2.3 The Choice of Steel for Low Frequency Magnets.

In this section the properties of the various steels that are available for low -frequency magnet applications are discussed. Much of the alternating effects, this topic has been held over from the first paper and is also discussed here.

To limit eddy losses, steel cores are laminated, with a thin layer ($\sim 2 \mu\text{m}$) of insulating material coated on one or both sides of each lamination. At 10 Hz, lamination thickness of 0.5 mm to 1 mm can be used. At 50 Hz, lamination thickness of 0.35 mm to 0.65 mm are more usual.

Steel also has hysteresis loss, caused by the finite area of the B/H loop in each a.c. cycle. The magnitude of the hysteresis loss is strongly dependent on the formulation of the steel 'mix', on the necessary rolling of the material to form the laminations and the subsequent annealing process that is vital to provide good magnetic properties and low losses. The magnet designer is therefore dependent on the steel manufacturer to provide data on the expected losses, as a function of frequency and excitation. Manufacturers provide catalogues of standard data giving figures for the magnetic properties and the total loss (in W/kg) in their steels as a function of field (European standard is at 1.5 T peak), and at a stated frequency (50 Hz in Europe). Separate figures for eddy and hysteresis loss are difficult to obtain, as are projected performance figures for unusual operating conditions, such as fully biased excitation and non-standard frequencies.

The accelerator builder must appreciate that, apart from the largest international projects, the weight of steel that is required for a complete magnet system is financially insignificant to most

Variation with:	Eddy loss	Hysteresis loss
A.c. frequency:	Square law;	Linear;
A.c. amplitude:	Square law;	Non-linear; depends on level;
D.c. bias:	No effect;	Some increase;
Total volume of steel:	Linear;	Linear;
Lamination thickness:	Square law;	No effect;

Box 4: Comparison between eddy and hysteresis losses in steel.

national steel companies. Hence, good will and the prestige value of an accelerator order are the only means of persuading a manufacturer's laboratory to carry out special magnetic and loss tests. However, much information can be obtained by extrapolating from the standard curves and tables. Box 4 gives the relationships that can be used to calculate the eddy and hysteresis losses in a non-standard application, from conventional data. For example, the hysteresis loss varies linearly with frequency whilst the eddy loss follows a square law; many manufacturers will quote losses at both 50 Hz and 60 Hz, and hence the two components can immediately be separated.

Many different types of steel are manufactured for magnetic applications. Sheet material can be divided into 'grain oriented' and 'non-oriented' grades with varying quantities of silicon present. 'Soft' material with very low carbon content and no silicon is also available; this can be in sheet form but is more usually purchased as solid forgings. The properties and uses of these various grades are summarised below.

Grain oriented sheet steel has a high silicon content and is strongly anisotropic. It has very high quality magnetic properties and very low loss figures in the 'rolling direction' – the axis along which the sheets were rolled in the steel mill to obtain the required thickness. Grain oriented material must be used with the magnetic flux in the rolling direction, for normal to that direction it is very much worse than non-oriented steel. When used in transformers, rectangular strips of grain oriented steel are assembled, with the correct orientation, to form the limbs of a yoke, the corners being 'interleaved' to eliminate gaps in the magnetic circuit; such treatment is difficult in the case of accelerator applications. Furthermore, stamping and machining during magnet manufacture causes loss of magnetic quality and increase of losses. Stamped grain-oriented laminations must be annealed at high temperature before final assembly to obtain the characteristics advertised by the manufacturer. This additional treatment, together with the problem of designing a lamination in which the flux is always running parallel to the rolling direction, makes grain-oriented material an infrequent choice for standard accelerator magnets. However, it can be used to advantage in specialised applications.

Non-oriented sheet steel has some anisotropy (~5%), and is manufactured in many different grades, with the magnetic and loss parameters controlled by the percentage of silicon included in the original mix. Again, rolling and the subsequent annealing of sheet material, usually

in this case by the steel manufacturer before delivery to the customer, are important. High silicon gives low losses but poorer magnetic performance at high field. The presence of the silicon also mechanically stabilises the steel so that laminations can be stamped and assembled without loss of performance or the need for subsequent annealing. Of particular importance to the magnet designer is the enhancement of permeability at low fields and the reduced value of coercivity that results from the inclusion of silicon. These requirements would be of over-riding importance for a synchrotron application with low injection field, and the designer may then be prepared to sacrifice high-field performance by using a high-silicon grade. Conversely, a storage ring application with injection at or close to the operational energy would favour a steel with low silicon content and better high-field permeability. For reasons mentioned below, a laminated steel would still generally be regarded as the best solution.

Low carbon steels are used for d.c. or very low frequency magnets, where high field performance is paramount. Solid steel, with very low levels of impurities can be obtained, or laminated material, containing little or no silicon is available. Very good magnetic properties at medium and high fields are obtained in both types of material, at the expense of a large hysteresis loop, which produces strong remanence effects. Only accelerator magnets that have a very high peak field specification are made from such magnetically 'soft' material, though it is standard for experimental and beam-line magnets. It should be noted that in a solid magnet used in an application where the field level is critical, the magnetic effects of eddy currents may be apparent for up to a few minutes after switch-on.

To illustrate these effects, Box 5 gives data for three differing types of steel: a non-oriented low-silicon material (in laminated form), a non-oriented high-silicon sheet steel, and a high quality grain-oriented sheet steel (along the grain).

	Non-oriented low-silicon	Non-oriented high-silicon	Grain-oriented (along grain)
Silicon content	Low (~ 1%)	High (~3%)	High (~3%)
Lam. thickness	0.65 mm	0.35 mm	0.27 mm
A.c. loss (50 Hz): at 1.5 T peak	6.9 W/kg	2.25 W/kg	0.79 W/kg
μ (B = 0.05 T)	995	4,420	not quoted
μ (B = 1.5 T)	1680	990	> 10,000
μ (B = 1.8 T)	184	122	3,100
Coercivity H_c	100 A/m	35 A/m	not quoted
Box 5: Comparison between a low-silicon non-oriented steel, a high-silicon non-oriented steel, and a grain-oriented steel			

This steel data is taken from the standard brochure of a national European steel manufacturer. Note:

- there is nearly an order of magnitude decrease in a.c. loss at 50 Hz between the low-silicon and the grain oriented material;
- the high-silicon material has a much larger value of permeability at the low flux density value of 0.05 T compared to the low-silicon grade; this enhanced low-field performance is also demonstrated by a factor of three reduction in coercivity, the parameter that will determine the residual field in the magnet at injection; the manufacturer does not give low-field parameters for the grain-oriented grade, as in power distribution applications this material will always be operated at high flux densities;
- the poorer permeability of the high-silicon grade at high inductions and the spectacular values of permeability of the oriented compared to the non oriented grades.

2.4 Magnet Inductance.

Before moving to the topic of a.c. magnet power supplies, it is worthwhile examining the significance and calculation of magnet inductance, which is the measure of stored magnetic energy. Some relevant relationships are given in Box 6.

Inductance of a coil defined as:

$$L = N\Phi / I$$

For an iron cored dipole:

$$\Phi = B A = \mu_0 n I A / (g + \ell / \mu);$$

g is gap;
 ℓ is length of steel path;
 A is total area of flux;
 μ is permeability of steel;

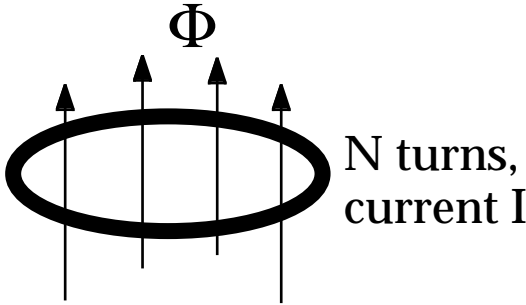

Inductance of the magnet: $L_M = \mu_0 N^2 A / (g + \ell / \mu);$

Note that $A \approx \Lambda_M (b + 2g);$

Λ_M is magnetic length;
 b is pole breadth;
 g is pole gap.

Box 6: Inductance of a dipole magnet.

From the formal definition of inductance as the total magnetic flux per unit exciting current cutting a coil with N turns, it is straightforward to establish the inductance of a simple dipole magnet. In this relationship, it is important to realise that A , the flux cross section, must include the fringe flux **on either side of the pole**; a 'rule of thumb' for giving a rough estimate of this is given in Box 6 (or see Box 16 of the first article on Conventional Magnet Design). Note that in the direction of the beam, the fringe field also adds to the particle deflection, so, providing the magnetic length and not the physical length is used, the fringe field **at the magnet ends** is not included when calculating A .

Magnet inductance determines the operating voltage and hence power supply rating of an a.c. magnet system; it is therefore important to minimise it in an a.c. magnet design. Most modern magnetostatic codes will provide the necessary information to allow inductance to be calculated. This can either be as the total stored energy in a magnetic assembly or as a plot of vector potential. In a two-dimensional problem this vector field quantity is, at all points, normal to the plane in which the magnet has been defined. In this plane it has values equal to the change in total flux per unit magnet length from an arbitrary origin. The difference between the vector potential at two points, multiplied by the magnetic length, therefore gives the total flux between those points.

A number of somewhat unexpected relationships are uncovered when dealing with magnet inductance. For example, for two identical coils on the same magnet yoke, with full flux coupling, the series connection results in an increase in a factor of four in the inductance, whilst a parallel connection leaves the inductance unchanged, as illustrated in Box 7. However, if there is no mutual coupling, inductors connected in series or parallel follow the same relationship as resistors connected in the same configuration.

Power supply voltages will be proportional to the operating frequency and also the product of the inductance and the exciting current i.e. to the bending power of the magnet. Variation in the physical length of the magnet, with a corresponding adjustment to field strength, will therefore not change the voltage. The number of turns per coil is then the only significant variable at the disposal of the a.c. magnet designer to change the power supply voltage. Once this is chosen and the required pole width determined, the total alternating voltage in the circuit is fixed, for a fixed beam energy and frequency. Depending on the operating frequency, the alternating voltage in an a.c. magnet system will be one to two orders of magnitude greater than the resistive voltage.

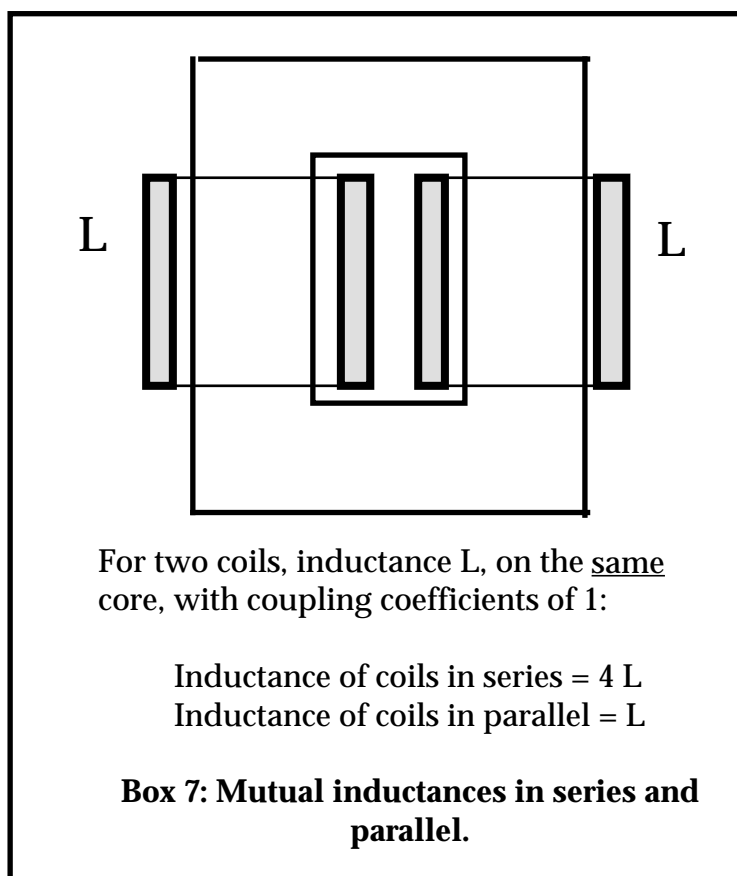

2.5 Low Frequency a.c. Power Supply Systems

The major difficulty facing the designer of an alternating power supply for accelerator applications is the large amount of energy that must be transferred to the magnets during the acceleration part of the cycle, and subsequently removed, to lower the field for the next injection. In an accelerator supply, the instantaneous power rating of this transfer of energy, to and from the magnet, will depend on whether the system is slow cycling (~ 1 Hz or less), or fast cycling (typically 10 to 50 Hz); it will be of the order of 1 MVA or more in any appreciably sized system, and in a large fast cycling circuit can exceed 100 MVA. It is both uneconomical and environmentally unfriendly to 'dump' this energy each cycle, so it must be stored in an appropriate energy storage device. A primary power source will be needed to make up the a.c. and d.c. losses and this will have a rating that is one to two orders of magnitude less than the reactive power rating of the magnet circuit.

A number of different methods have been used to tackle the energy storage problem. Before the advent of strong focusing, the physically large magnets had very high stored energies. Alternators, of a size that would be used in a small power station, were coupled to large energy storage fly-wheels and the direction of transfer of energy was determined by phase controlled rectifiers at the output of the alternator. Such systems were suitable for the slow cycling proton synchrotrons built in the 1950s and 60s. With the design of the CERN SPS, the method of 'direct connection' to the high voltage distribution system was perfected. This used the very large energy storage capacity of a national grid system as the temporary repository of the magnet energy during the low field part of the cycle and is the standard method now used for slow cycling systems.

With cycling rates of the order of 10 Hz or higher, fast-cycling synchrotrons can use neither mechanical energy storage nor direct connection. Over the last three decades, a resonant circuit containing both inductive and capacitive energy storage has been developed and this is the standard power supply system for accelerators with rapid repetition rates. The circuit, known as the White Circuit after Prof. Milton White of the Princeton-Penn Accelerator, generates a magnet current in the form of a fully-biased sine wave, as shown in Box 8.

The power circuit is shown in diagrammatical form in Box 9. In the general case, the network is divided into a number of individual cells (the network in the diagram contains four cells). The magnets L_M are in series to ensure current equality, and between each 'cell' of magnets there is connected a series resonating capacitor which has a d.c. bypass inductor connected in parallel. For economic reasons, the multiple windings of this inductor are wound on a common iron core, the

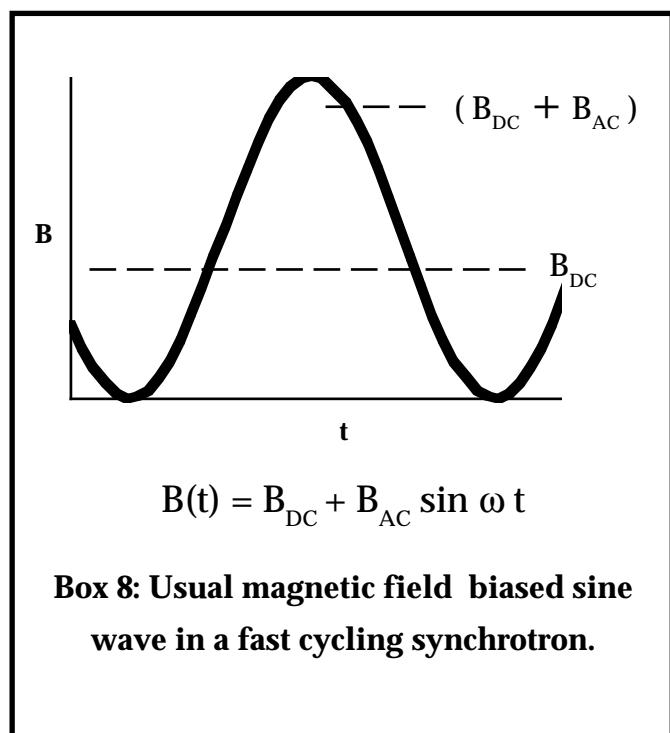

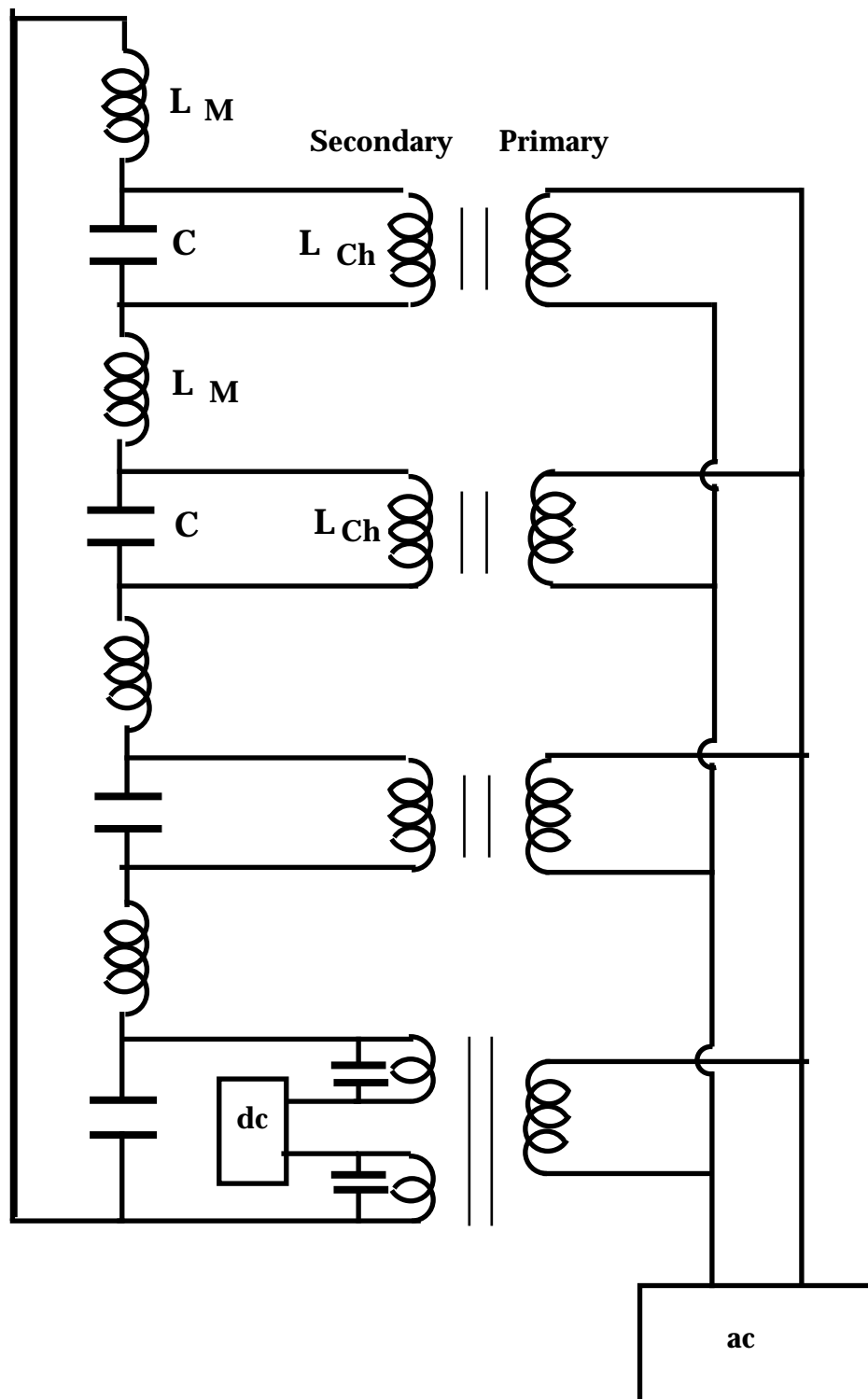

Box 9: The 'White Circuit' - the standard circuit configuration used to power fast cycling synchrotrons. The magnets L_M are resonated by series capacitors C . The auxiliary inductor L_{Ch} provides a path for the d.c. bias. The diagram shows a four-cell network.

resulting device being referred to as the 'energy storage choke'. Note that each capacitance C must be adequate to resonate both one cell of magnets in series and one choke winding in parallel; ie

$$C = 1/(\omega^2 L_M) + 1/(\omega^2 L_{CH})$$

where ω is the oscillation frequency of the power supply system.

The required direct current bias is introduced by connecting a rectifier set at the mid point of a special split winding of the energy storage choke; this is usually the position of the network earth. A.c. power is generated by an alternating power source, usually an inverter, connected to a further set of windings also wound on the yoke of the energy storage choke. These additional coils are usually referred to as the 'primary' windings, and are magnetically closely coupled to the main choke coils, which are therefore referred to as the 'secondary' windings. The device is therefore both an inductor and a transformer.

The important features of this circuit, that make it well suited for powering fast-cycling synchrotrons, are:

- * the magnet waveform is close to ideal;
- * the a.c. and d.c. power sources are electrically isolated from each other;
- * the magnet voltages are not cumulative, for the alternating voltage across the capacitor and choke winding is π out of phase with the magnet voltage; whilst the total magnet voltage may be in excess of 100 kV, the voltage to earth can be kept an order of magnitude lower by dividing into larger numbers of cells;
- * the power drawn from the public supply system represents an almost steady load, with a power factor close to one;
- * in addition to feeding power to the network, the primary windings on the energy storage choke also balance the network voltages and stabilise the oscillations at the required fundamental frequency.

3. HIGH FREQUENCY MAGNETS

3.1 Magnets used in Injection and Extraction Systems

In general, the injection and extraction systems of accelerators require two types of magnet systems - called '**kicker**' and '**septum**' magnets.

The kickers are used for the temporary, very rapid displacement of the closed orbit that is needed, either to accept a newly injected beam into a stable, unobstructed orbit, or to move the beam close to the final extraction element at the end of the acceleration process, prior to extraction. In either case, the kicker magnets in an accelerator (for usually more than one is needed) are required to have waveforms that provide a constant deflection for some period of time with a very rapid switch-on and/or switch-off, depending on the beam orbit dynamics that are required. Pulse

time scales are typically of the order of 10^{-6} s, with rise and/or fall times of less than 10^{-7} s being achievable. In such circumstances, the short, high-current pulses require very high voltage generators and the design of the magnet and associated power supply must be fully integrated.

The change of closed orbit produced by the kickers usually moves the beam path into the field of a septum magnet, and this device then provides the necessary deflection to the incoming or outgoing beam to match the angle of the beam transfer line to the accelerator orbit. The essential feature of a septum magnet is the need to have two distinct regions of magnetic field: a high, approximately spatially constant region that produces the required uniform beam deflection, and a very low (ideally zero) field region through which the circulating beam can pass without suffering unacceptable deflection or orbit distortion. The space between these two regions is usually occupied by a thin conductor (the septum) and hence beam entering this area strikes the septum and is lost. It is therefore the aim of the designer to minimise this unuseable region. Septum magnets are not, *per se*, high-frequency, pulsed devices, and can be designed using conventional d.c. techniques. However, it will be seen that the technical and economic advantages of using pulse techniques justify the inclusion of these magnets as a special case in this high-frequency section.

In view of the very different natures of kicker and septum magnets, and their associated power supplies, they will be treated separately.

3.2 Kicker Magnet Systems

The magnetic requirements of a kicker magnet are relatively straightforward – the device is required to generate a region of flat field which can be turned on and off rapidly. Field volume, and hence stored energy, has significant economic and technical consequences in any a.c. magnet system, and with switching time of much less than $1 \mu\text{s}$, it is vital to minimise the gap height and pole breadth in a kicker magnet. These requirements are usually best met by the standard window-frame dipole design, as shown in Box 10, with the magnet often placed inside the accelerator vacuum system, to minimise the aperture. This also eliminates the problem of the penetration of the rapidly changing magnetic field through the walls of the vacuum chamber; if the magnet is not included in the accelerator vacuum, a high-resistivity, non-magnetic (usually ceramic) vessel is required. It should be appreciated that the diagram in Box 10 is schematic; the detailed design of a kicker magnet will involve stringent electrical and mechanical engineering considerations that produce complex detailed designs.

The power supply is an inherent part of any successful kicker system design. A number of approaches to the complete magnet/power supply system are possible, but probably the most frequently used technique, and the one that has been adopted and further developed at CERN to meet the very high injection and extraction specifications of the

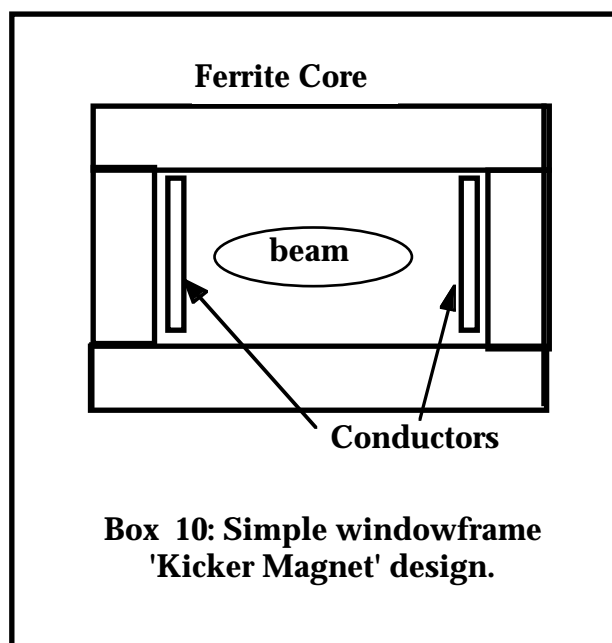

accelerator complex, uses the concept of delay line magnets and power supplies. A delay line is a circuit having distributed series inductance and parallel capacitance to earth; any pulse induced in such a delay line will travel along the line with a surge velocity and the ratio of the pulse voltage to current is given by the surge impedance of the line; providing the d.c. resistance of the line is low, both the surge parameters are determined by the distributed inductance and capacitance.

The advantage of such an approach to a kicker magnet system is that the high-frequency, square-current pulse can be generated at the power supply and transmitted to the magnet with little degradation of pulse shape or lengthening of rise time. A schematic diagram of a typical circuit is shown in Box 11, which also gives the equations for the surge impedance and the pulse transit time in terms of the line inductance L and capacitance C . In the diagram the power supply is to the left, and comprises a high voltage d.c. source which charges the delay line L_1, C_1 . This line can be a piece of high-voltage coaxial cable, or a set of lumped inductors and capacitors connected in an array of cells to produce a quasi-delay line.

To produce the required current pulse, the line is discharged by means of a thyatron T , which is a high frequency switching valve, capable of holding off tens of kilo-Volts when in the non-conducting mode, and conducting kilo-Amps when 'turned on' by a pulse on an auxiliary electrode; like the rest of the circuit, the thyatron will have a coaxial configuration. The high-current pulse is transmitted to the magnet, L_2, C_2 , through coaxial cables. The current pulse is close to square, so the field rise time in the magnet is determined by the pulse transit time through the magnet delay line. Note that the magnet may have different total inductance and

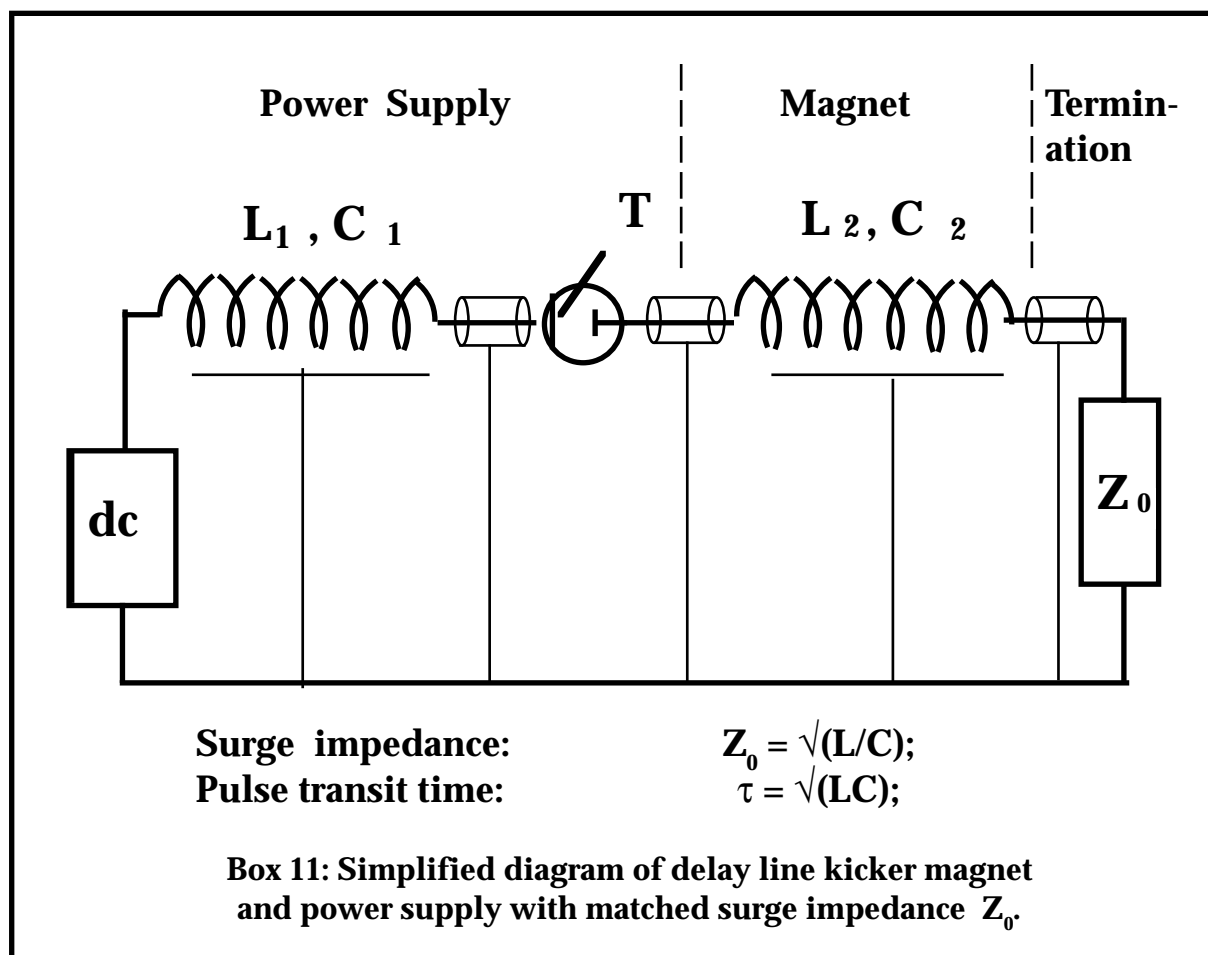

capacitance to the power supply line but the surge impedances of the complete system must be the same to avoid unwanted reflections of the pulse and give optimum transfer of energy. The inductance L_2 will be the inherent self inductance of the magnet, but the capacitance to earth, C_2 , is built into the magnet as an additional design requirement. The magnet is terminated by a matching resistor, shown as Z_0 in the diagram. This element is, ideally, a pure resistance, with a value equal to the surge impedance of the system, also to prevent reflection of the pulse.

The delay line magnet is often mechanically and electrically very complex, for the designer must incorporate the distributed capacitors by including conducting plates, connected to the high-voltage magnet winding, interleaved with a corresponding set of plates at earth potential, with a thin dielectric separating layer. The magnet core will be assembled from a high-frequency ferrite material (see later section) which usually will not tolerate high-voltage stress. Hence, ceramic insulators are needed to locate and restrain the magnet conductors. The whole assembly is mounted in the accelerator vacuum so that stringent vacuum specifications must be met; long term reliability is essential, as access to the magnet will be both difficult and costly in terms of accelerator down-time.

It should be understood that kicker-magnet power supplies are also highly detailed and complex; the description given here is of a simplified nature. Alternative configurations, with different behavioural characteristics, have been developed for specialised applications and in practice the circuits can be further modified by small trimming elements that sculptor a required pulse waveform. The theory and practice of kicker magnet power systems are closely related to the modulator technology that is used in radar and other pulsed r.f. systems and there is an extensive body of literature and conference proceedings covering the topic.

The delay line method of generating high-current pulses has a number of advantages and disadvantages, as summarised in Box 12. Perhaps the most important advantage is the possibility of locating the power supply remotely from the magnet, using up to ten meters of interconnect-

Advantages:	Disadvantages:
Very rapid rise times (<0.1 μ s);	Volts on power supply are twice the pulse voltage;
Good quality flat top on square current pulse;	Pulse voltage (10 s of kV) present on magnet throughout pulse;
Matched connection allows supply to be remote from magnet;	Complex and expensive magnet;
Reverse volts on valve are not large;	Difficulty with terminating resistor manufacture;
Box 12: Advantages and disadvantages of using matched 'delay-line' type kicker magnet and power supply circuit.	

ing coaxial cable with little or no loss of pulse amplitude or distortion to the flat top. Thus, the power supplies can be in service buildings that are accessible at times when there is beam in the accelerator. A serious disadvantage of this circuit is the presence of the pulse voltage (often tens of kilo Volts) between the magnet and earth throughout the pulse, for even though the current in the magnet is unchanging during the flat portion of the pulse, the delay-line voltage is still present across the terminating resistor. Furthermore, the delay line must be initially charged to twice the required pulse voltage.

Because of these problems, alternative circuits have been developed that use lumped inductive magnets, with no additional capacitance added to produce delay lines. As examples of 'lumped' systems that can be used, two simple circuits are shown schematically in Box 13. In the first, the magnet pulse is generated by discharging a capacitor through the magnet, a resistor R being used to generate a distorted half sine-wave that will provide some degree of flatness over a limited time. In the second circuit, the capacitor has been replaced by a delay line, which is discharged through a matching resistor into the lumped magnet to give improved flatness. The

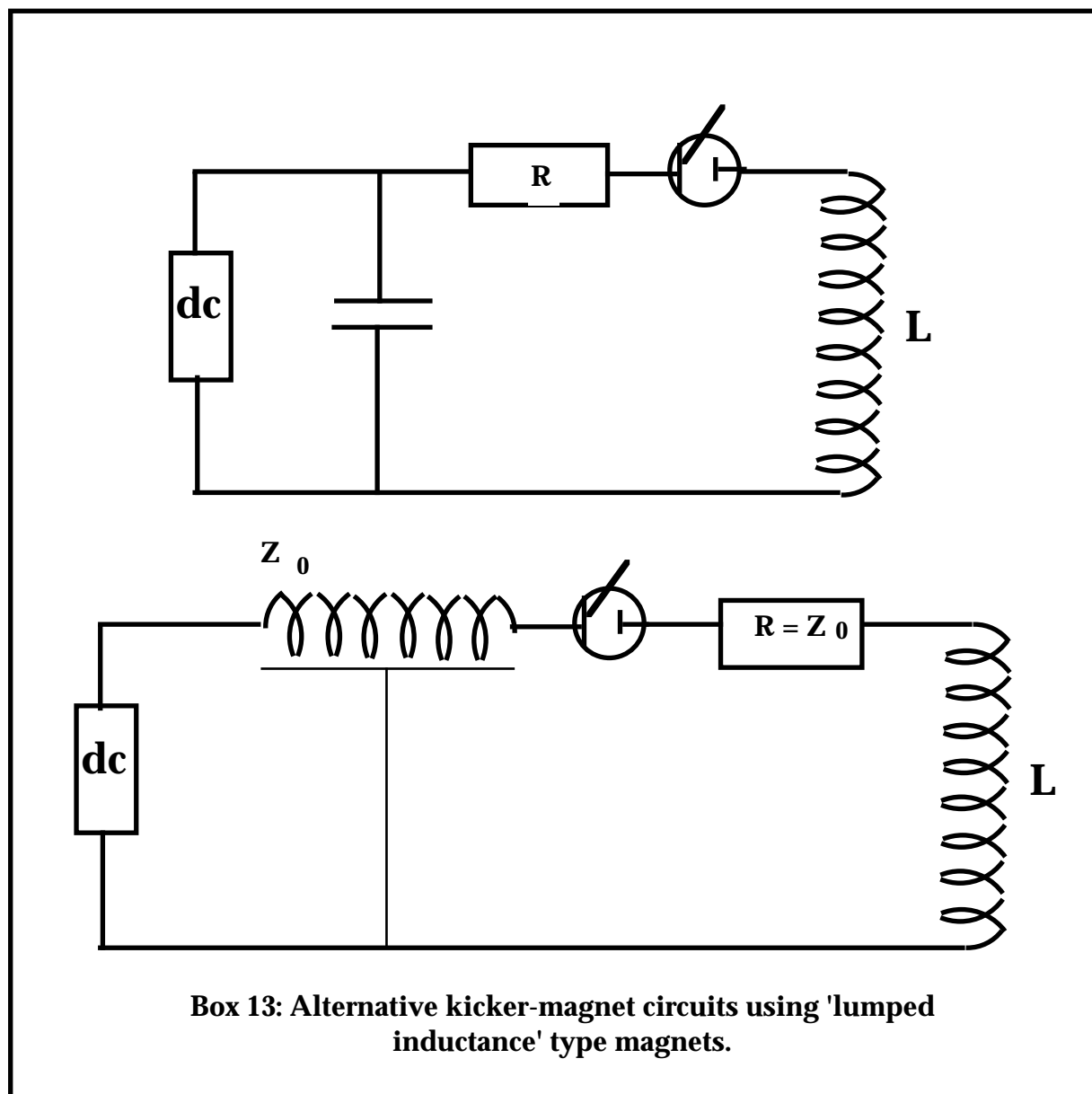

advantages of such circuits are that the d.c. power supply volts are now equal to the pulse voltage, and this only appears on the magnet during the pulse rise or fall; the magnet becomes much simpler and costs are substantially reduced. The very major disadvantage is that the inductance in the magnet interconnections must be minimised, so the power supply must be located immediately next to the magnet, with interconnections as short as 100 to 200 mm. There is also the possibility of a large negative voltage appearing across the switching valve at the end of the magnet pulse, and this can seriously limit the life of this expensive device.

Notwithstanding these problems, non-delay line systems result in simpler magnets. These can be as basic as a set of conductors, comprising one or two turns, mounted in the accelerator vacuum with no ferromagnetic materials present. The power supplies also tend to be of a simpler nature, and successful designs based on these methods have been used in many accelerators, with substantial reductions in capital costs.

3.3 Septum Magnet Systems

The role of the septum magnet was summarised in 3.1 above; the magnet is usually located inside the machine vacuum and deflects the incoming or out-going beam. It was explained that it was possible to use d.c. techniques for this type of magnet and such a device is shown in the upper half of Box 14 as the 'conventional design'. The simple C-core yoke has the coil placed in the plane of the beam, as in a window-frame design. The other conductor, placed inside the throat of the magnet, is not subject to any dimensional constraints. The outer component of the coil forms the septum and must therefore be as thin as possible; this dimension will usually be of the order of a few millimetres. Because of the problems of introducing inter-turn insulation into this small space, such septum magnets usually have a single-turn design. The septum is shown extended over the full height of the magnet gap. As explained in the paper on d.c. magnets, provided the permeability of the magnetic material is high, this configuration provides a flat field distribution up to the surface of the septum with zero field to the right of the conductor.

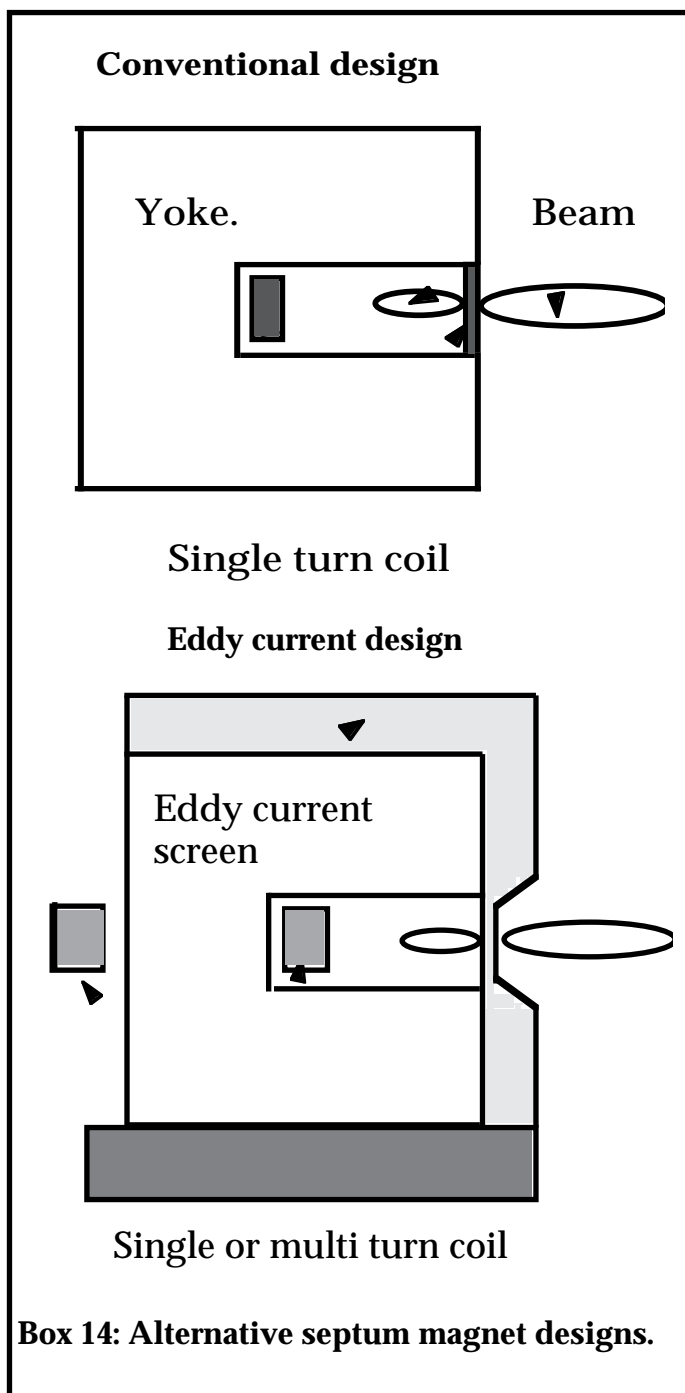

Box 14: Alternative septum magnet designs.

This is the required distribution, for the circulating beam is to the right of the septum, with the injected or extracted component receiving a deflection inside the magnet, as indicated in the diagram.

The major problem with d.c. excitation in this design is the very high current density required in the outer conductor. With an internal field of 1 T and a 1 mm thick septum, the required direct current density in this conductor is of the order of 800 A/mm². This results in a major thermal loading problem which, in the case illustrated, is probably un-resolvable; in a practical design, the septum would have to be thickened to between 5 mm and 10 mm, and water cooling introduced into this region, where space is at a premium.

A possible solution is to excite the magnet with a half sine-wave current pulse, using a pulse length that provides sufficient flatness at the peak of the waveform during the short time that beam is present in the magnet. This will reduce the heat loading by a factor equal to the duty-cycle of the magnet. Additionally, the pulse excitation can be used to further reduce the septum thickness and eliminate the thermal loading problem by means of the design modification illustrated in the lower diagram of Box 14. The magnet shown is powered by a coil wound round the backleg. The space in this area is not critical and large conductor cross sections can be used, with multiple turns if required. In a d.c. magnet this would produce a very poor field distribution (the back-leg is the worst place for locating a coil), but with a pulsed design a substantial modification can be produced by the presence of the eddy-current screen shown in the diagram. This is a skin of high-conductivity material (usually copper) surrounding the C-core at the front, top, bottom and ends. The penetration of a high-frequency magnetic field into a conductor is defined by the skin depth of the conducting material which is defined in Box 15. Providing the thickness of the conductor surrounding the magnet is much greater than the skin depth corresponding to the frequency of the pulse, the field will be almost completely constrained within the magnet gap and a flat field will be obtained up to the surface of the septum. In the diagram, a very thick screen is used in non-

critical regions, and is reduced to a minimum acceptable thickness in the septum region. Currents are generated in the screen and these have the required configuration to prevent the field penetrating the conductor. However, as they are not providing the main excitation to drive flux across the gap, they are an order of magnitude less than the current needed in the septum in a conventional design. Ohmic heating still occurs in this region, but the heat is conducted down to the magnet base plate, which is electrically and mechanically bonded to the screen. The heat is then conducted from the base plate to atmosphere by whatever conventional means are most appropriate.

Skin depth in material:

resistivity ρ ,
 permeability μ ,
 frequency ω , is given by:

$$\delta = \sqrt{2 \rho / \omega \mu \mu_0}$$

Example: (SRS injection septum magnet)

Screen thickness (at beam)	1 mm;
" " (elsewhere)	10 mm;
Excitation pulse	25 μ s, half sinewave;
Skin depth (copper, 20 kHz)	0.45 mm,
Injected beam pulse length	< 1 μ s.

Box 15: Criteria relating to eddy current septum magnets.

	Conventional:	Eddy current:
Excitation	d.c. or low frequency pulse;	pulse: waveform frequency > 10 kHz; low repetition rate;
Coil	single turn including front septum;	single or multi-turn on backleg allows large cross section;
Septum cooling	complex water cooling in thermal contact with septum;	heat generated in shield conducted to base plate;
Yoke material	conventional steel;	high-frequency material (ferrite or radio metal).

Box 16 : Features of alternative septum magnet designs.

The features of the two alternative designs are summarised in Box 16, whilst Box 15 provides information on skin depth criteria and gives an example of use in an accelerator application where a septum thickness of 1mm at the beam was obtained. This data also shows that adequate flatness was obtained in the central 1 μ s region of a 25 μ s pulse. This is therefore a rare case of eddy currents being beneficial, and being used by the designer to produce desirable results that would otherwise be difficult or impossible to achieve.

3.4 High-Frequency Magnetic Materials.

A number of different magnetic materials are available for high-frequency pulsed magnets. The standard high-frequency material that is used in the radio industry is ferrite, and grades specified for operation at frequencies that are much higher than those considered in this paper are available. Detailed information relating to permeability, saturation flux density and a.c. losses can be obtained from the appropriate manufacturers. In general, however, the higher the specified frequency of operation, the lower the saturation flux density and permeability. In material specified for Mega-Hertz operation, these parameters are so low that magnet performance would be considerably compromised.

For lower frequency pulsed applications, various specialised steels are available. These are often nickel-iron alloys, produced in lamination form with thickness of the order of 0.1 mm. They have permeabilities and saturation flux densities normally associated with good quality transformer steel, and are specified for operating frequencies up to a few kilo-Hertz.

Magnet designers should, however, be aware that the operational data for these high-frequency materials are presented for transformer applications, where, in the absence of a gap, the

Transformer:

$$\text{Inductance} = \mu\mu_0 n^2 A/\ell;$$

ℓ is length of magnetic circuit,
A is cross section area of flux;

Magnet:

$$\text{Inductance} = \mu_0 n^2 A/(g + \ell/\mu); \quad g \text{ is gap height.}$$

ie $L(\text{magnet}) \ll L(\text{transformer})$.

Losses appear as resistance in parallel with inductance; they are therefore much less significant in a magnet.

Skin-depth effects modified by gap:

The gap also decreases the magnetic effect of eddy currents in the laminations, which control the penetration of flux into the steel:

$$\delta \approx \sqrt{\{ 2 \rho g / \omega \mu_0 (\ell + g) \}}$$

Box 17: Criteria relating to choice of material in a high frequency magnet.

primary inductance is directly proportional to the core permeability; any reduction in permeability will result in increased magnetising current. Furthermore, the eddy and hysteresis losses appear as a resistance in parallel with the high primary inductance, and therefore even a small increase in losses will result in a reduction in the transformer efficiency.

These criteria do not apply in an electromagnet, where the coil inductance will be very much less than that in a transformer. There is consequentially a very high magnetising current and the parallel loss currents will have much less significance. Changes in the core properties are therefore a lot less important, and the magnet can operate effectively with permeabilities and losses that would be unacceptable in high frequency transformer applications.

This situation is explained a little more fully in Box 17, which also indicates that the presence of the gap also modifies the magnetic effect of eddy currents. The permeability term that appears in the skin depth equation is then modified; the ratio of the eddy currents in the laminations to the magnetising current in the excitation coil is one to two orders of magnitude lower than in an ungapped core and the magnetic flux is able to penetrate the laminations more effectively. The situation is further complicated by the concentration of flux into the outer regions of the laminations causing non-linearities and different regions of the laminations will have different permeabilities. The equation for skin depth given in Box 17 must therefore be regarded as an approximation, to demonstrate the significant increase that will occur in the case of an inductor.

The consequence of these effects is that a magnetic material that is used in a gapped magnet can be operated at a much higher frequency than that given in the material specification. This is illustrated in Box 18, which compares the operating characteristics of the SRS eddy-current septum with the operating data published by the manufacturer of the nickel-iron laminations. It can be seen that the magnet is operating at a frequency roughly an order of magnitude higher than that recommended in the published data. The 0.1 mm laminated material performed adequately, with no excess losses or indications of saturation, in spite of the skin depth in this material at the operating frequency being of the order of 0.01 mm in an ungapped core.

Application:

Type of septum:	Eddy current;
Excitation:	25 μ s half sine-wave;
Effective frequency:	20 kHz
Material used:	Nickel Iron Alloy
Lamination thickness:	0.1 mm
Skin depth (nickel-iron $\mu \sim 5,000$)	~ 0.01 mm

Lamination manufacturer's data:

Max frequency quoted
in μ and loss curves: 400 Hz

Max recommended
operational frequency: 1 kHz

Box 18: Example of use of magnetic material at higher than recommended frequencies.

4. CONCLUSION

This paper resulting from the second seminar on conventional magnets has covered a much wider range of topics than the first paper and has, consequently, dealt with them in a less detailed way. However, the intention has been to highlight the fundamental features of the designs so that those new to the topic can identify the areas where more detailed examination will be necessary and roughly the direction that the further study should take.

Notwithstanding the distinctive features of a.c. and pulsed systems, it should be clear that the design of such magnets is fundamentally based on the magnetostatic topics introduced in the first seminar, but with additional constraints and considerations that are necessary for a successful magnetodynamic project. These are to be found in a number of areas that belong in academic electrical engineering degree courses, including power, high-voltage and radio-frequency engineering. Whilst the design of d.c. magnets can be undertaken by accelerator builders without such experience, the more stringent and demanding requirements of the a.c. systems described in this paper need such experience and expertise to achieve an effective and reliable design.

BIBLIOGRAPHY

Many examples of the design of a.c. and pulsed magnets together with suitable power supplies are given in the proceedings of the series of International Conferences on Magnet Technology. Given below are the dates and venues of these conferences:

- 1965 Stanford Ca, USA;
- 1967 Oxford, UK;
- 1970 Hamburg, Germany;
- 1972 Brookhaven N.Y., USA;
- 1975 Rome, Italy;
- 1977 Bratislava, Czechoslovakia
- 1981 Karlsruhe, Germany;
- 1983 Grenoble, France;
- 1985 Zurich, Switzerland;
- 1989 Boston, USA.

Magnet Measurement Techniques

D.C. Magnets

Traversing methods:

The probe is traversed in the magnet. Its position is controlled and monitored to high precision; a map of field in two (or three) dimensions is generated. This can take (many) hours to measure a magnet - best used for dipoles.

Probe types:

NMR probes:

Very high accuracy and sensitivity
(parts in 10^6 or better);

Only possible in very homogeneous field;

Large probe (~10 mm cube);

Limited range of field;

Best used as absolute standard.

Hall probes:

Need temperature stabilisation/compensation;

Accurate to better than 10^{-4} T;

Cover a large range of field;

Small compact probe;

No range limitation.

Flip coils:

Usually used as transfer standard between
NMR and Hall probes.

Coil Methods

Rotating coil:

'State of the art' method for quads and sextupoles;

High precision coil with multiple harmonic windings rotates slowly for ~ 1 turn in bore of magnet;

Induced volts are integrated w.r.t angle (not time!);

Integrated signal is Fourier analysed to obtain harmonics phase and amplitude values;

Coils with fundamental rejection give greater signal to noise ratio for harmonics;

Long coils give total integrated fundamental and harmonics through magnet;

Very rapid and efficient measurements (< 1 hour);

Full automated systems available commercially.

LEP and ESRF quadrupoles and sextupoles all measured using such systems.

A.C. Measurements.

Coils:

The induced voltage in a coil makes this method very practical. A variety of techniques are available using either small traversing coils (for spot measurements) or long coils for integrated measurements.

Peaking strips:

Small thin pieces of ferromagnetic material with square hysteresis loop. They are wound with coils of very fine wire which produce a short pulse when H in the ferromagnet passes through zero. Calibrated bias coils can be added to produce the pulse at a predetermined level of B.

These devices are also very useful for control purposes in a.c. machines. In a 50Hz field rise times are $< 1\mu\text{s}$ and can therefore be used for synchronisation, timing and switching purposes.