

EUROPEAN ORGANIZATION FOR NUCLEAR RESEARCH
CERN - SL DIVISION

CERN-SL-98-076 PO

**The Novel Control Loops of the Pulsed
Power Converters for the CERN SPS Machine**

E. Ozturk*, M. Royer

Abstract

The topic of this paper is the studies that were made in the framework of the renovation project of the CERN SPS accelerator's power converters. This project was initiated because these converters were designed 20 years ago and they will need to work another 20 years, due to the use of the SPS machine as the LHC injector.

EP² Forum, ESRF - Grenoble, France, 21-22 October 1998

*) SERCO EUROPE LTD, Teddington, England

Geneva, Switzerland

01.12.98

The Novel Control Loops of the Pulsed Power Converters for the CERN SPS Machine

E. Ozturk*, M. Royer

CERN, Geneva, Switzerland

Introduction

Although the project covers the complete renovation of the converters, this paper treats only the design of the passive filter and the control loops.

During the design, great care has been taken to minimise the dependency of the control loops on the load, the power converter's characteristics (V_{max} , I_{max}) and the passive filter, in order to lessen the down-time of the SPS machine, during power converter repairs. Therefore, adjustments on the control loop cards have been eliminated.

Figure 1 depicts control loops of a typical thyristor phase-controlled power converter. We will study each control loop in detail. State feedback structures have been chosen to facilitate the parameterisation of the control loops. The use of a passive card called "the configurator" containing such parameters allows both modularity and independence. The use of precision components (op. amps and high-precision resistors) also makes high precision and performance possible with no adjustments. Practical results will be given to illustrate the design.

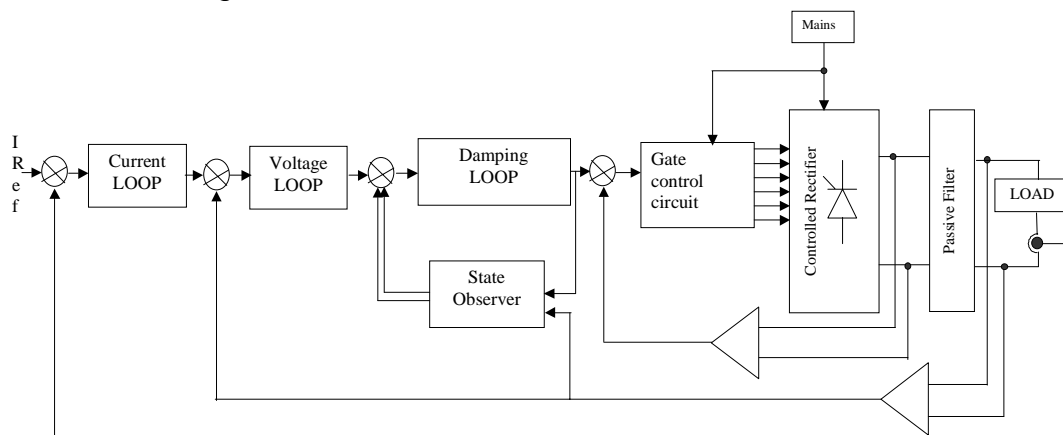

Figure 1 : The power converter and its control loop scheme

Electronic Damping Loop

The former passive filter was damped by a resistor, which was calculated to give a damping factor of 1. The passive filter has been modified to enhance the

* Ozturk - SERCO LTD.

rejection ratio at 50 Hz and its harmonics. We achieved this by adopting a lightly damped passive filter. The frequency responses of these two variants filters are shown in Fig. 2.

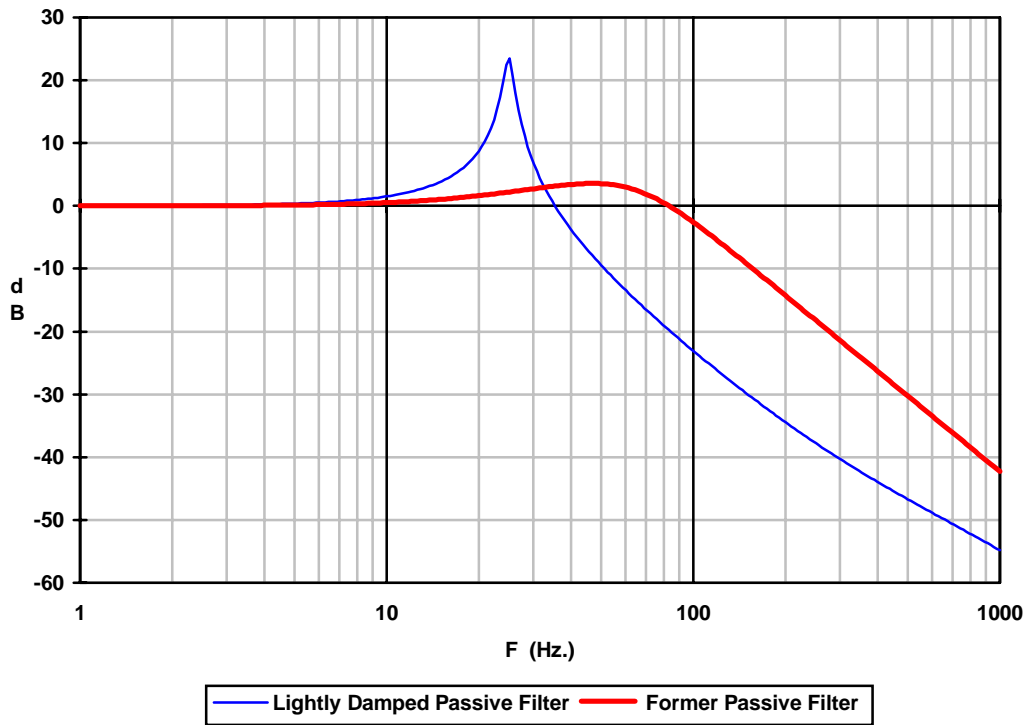

Figure 2 : Passive filters frequency response comparison

As a consequence, the passive filter can resonate. To avoid this, the filter is placed within a control loop. We have decided to use modern control techniques, e.g. state feedback. This technique requires the accessibility of the state variables, in our case the current through the filter inductance and the capacitor voltage, the latter being the only available information. Thus we need to build a state ‘observer’ in order to reconstitute the missing state variable. The scheme of a control loop using a state observer is shown in Figure 3.

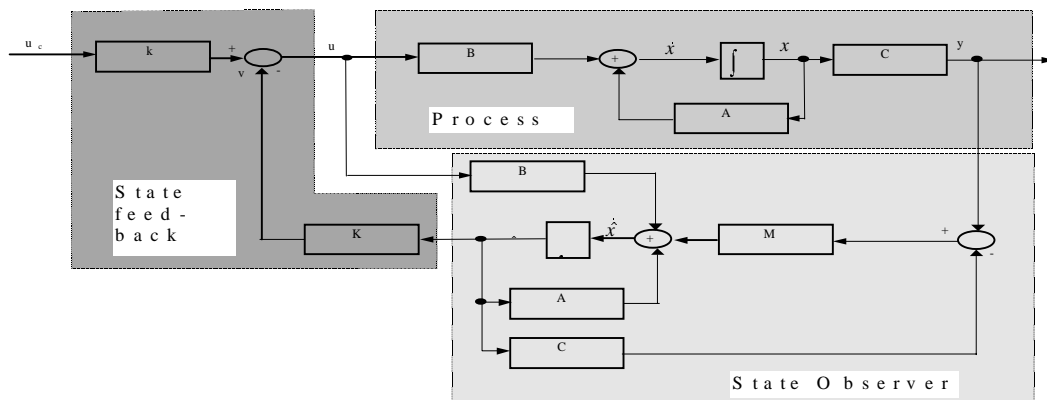

Figure 3 : Typical state feedback controller using a state observer

Modelling the Passive Filter

Electrically the passive filter is illustrated in the figure 4. Using the convention of this figure, the matrices for the state equations for the passive filter are :

$$A = \begin{pmatrix} 0 & \frac{-1}{LF} & 0 \\ \frac{1}{C2F} & \frac{Rd \cdot C2F}{Rd \cdot C1F} & \frac{1}{Rd \cdot C1F} \\ 0 & \frac{-1}{Rd \cdot C1F} & \frac{-(C1F + C2F)}{Rd \cdot C1F} \end{pmatrix} \quad B = \begin{pmatrix} \frac{1}{LF} \\ 0 \\ 0 \end{pmatrix} \quad C = (0 \ 1 \ 0) \quad D = 0 \quad x = \begin{pmatrix} x_1 \\ x_2 \\ x_3 \end{pmatrix} \quad \begin{matrix} u = V_B \\ y = V_F \end{matrix}$$

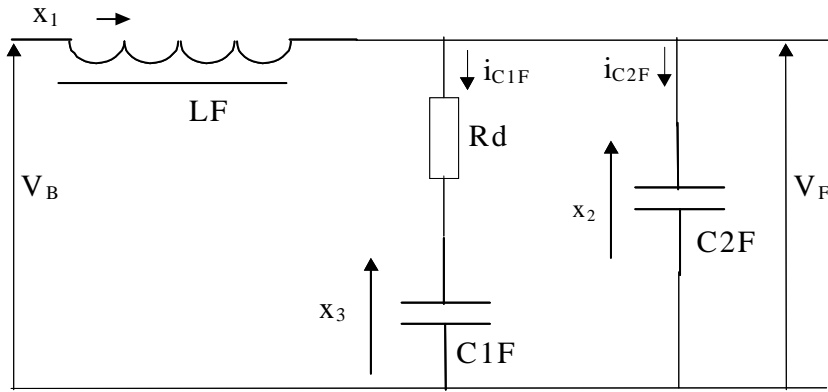

Figure 4 : Electrical equivalent circuit of the passive filter

Keeping in mind the fact that the passive filter is lightly damped, we can use a second order approximation. In this case the model is given in the controllable canonical form by :

$$A = \begin{bmatrix} 0 & 1 \\ -a & -b \end{bmatrix}, \quad B = \begin{bmatrix} 0 \\ 1 \end{bmatrix}, \quad C = [a \ b], \quad D = 0.$$

With : $a = \frac{1}{LF(C1F + C2F)}$, $b = \frac{C1F \cdot Rd}{LF(C1F + C2F)}$.

Determination of the Controller

Feed-back Matrix K

The feedback gains of the controller are obtained easily because the model is described in the controllable canonical form. The feedback matrix K in our case

(SISO) is a simple vector of 2 rows : $K = \begin{bmatrix} k_0 \\ k_1 \end{bmatrix}$. Let us assume that ω_v, ξ_v are

the natural angular frequency and the damping factors of the closed loop respectively. In this case the gains are given by :

$$k_0 = \omega_v^2 - a$$

$$k_1 = 2\xi_v \omega_v - b$$

This means that the closed loop bandwidth and damping factor are independent and can be assigned at will.

Forward Gain k

Generally state feedback controllers modify the DC gain of the process. The forward gain k is used to bring the DC gain of the closed loop system to 0 dB.

In our case this gain is given by: $k = \frac{k_0}{a} + 1$

Determination of State Observer

In order to represent the true state variables, the dynamics of the state observer must be faster than the original process, i.e. the poles of the state observer must be situated more to the left in the s plane than the passive filter poles. To limit the noise sensitivity of the state observer we have chosen a factor of four and an optimum damping factor (0.7) for the fastest settling time. This gives us

the observer feedback vector $M = \begin{bmatrix} m_0 \\ m_1 \end{bmatrix}$ defined by :

$$m_0 = \frac{2\omega_o \xi_o}{a} - \frac{b\omega_o^2}{a^2} \quad m_1 = \frac{\omega_o^2}{a} - 1$$

The observer natural angular frequency is ω_o and the damping factor is ξ_o .

Numerical Application

For a passive filter at 25 Hz, closed loop bandwidth at 80 Hz, damping factor of 0.7 and the bandwidth of the state observer at 100Hz. The parameters are :

$$k_0 = 228000, \quad k_1 = 698, \quad k = 10.24, \quad m_0 = 0.0275, \quad m_1 = 15.$$

Voltage Loop

As we have seen in the previous paragraph, the electronic damping loop has no integral term in the control law, therefore slow mains disturbances are not rejected by the electronic damping loop.

We have added a new controller on top of the electronic damping loop. This is called the voltage loop, see figure 5. The controller herein is made of a simple integral term : $C(s) = 1/\tau_i \cdot s$ and it is sufficient to fulfil the job of rejecting slow mains disturbances. The integration time is calculated to give a closed-loop bandwidth of 50 Hz.

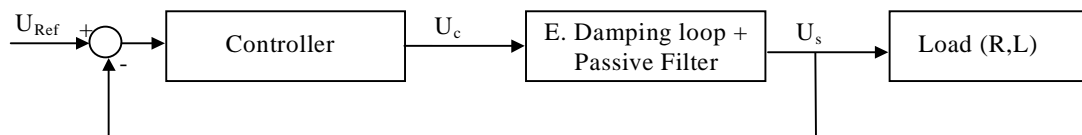

Figure 5 : The voltage loop

Current Loop

The current reference of the power converters is a series of pulses (trapezoids) which implies additional constraint on the current loop; the step response must be absolutely without overshoot, while being fast enough to have an acceptable ramp-error. This is achieved by employing a state feedback controller with feed-forward. The presence of the feed-forward term in the control law gives anticipation, speed of response and also introduces an adjustable closed-loop zero allowing pole-zero cancellation. Thus, the closed-loop transfer function is

reduced one order and simplified. The block diagram model of the current loop is shown in figure 6.

Taking into account that the closed-loop step response must be without overshoot, in order to stay on a pre-characterised hysteresis curve of the magnet, the controller parameters are dimensioned in order to have negative real-axis poles. Furthermore, those poles are triple i.e. placed on the same location for rapidity. As stated before, one of the poles is cancelled by the zero. Therefore, the complete closed-loop system can be seen as a second order plant with double poles. So the step response is without overshoot.

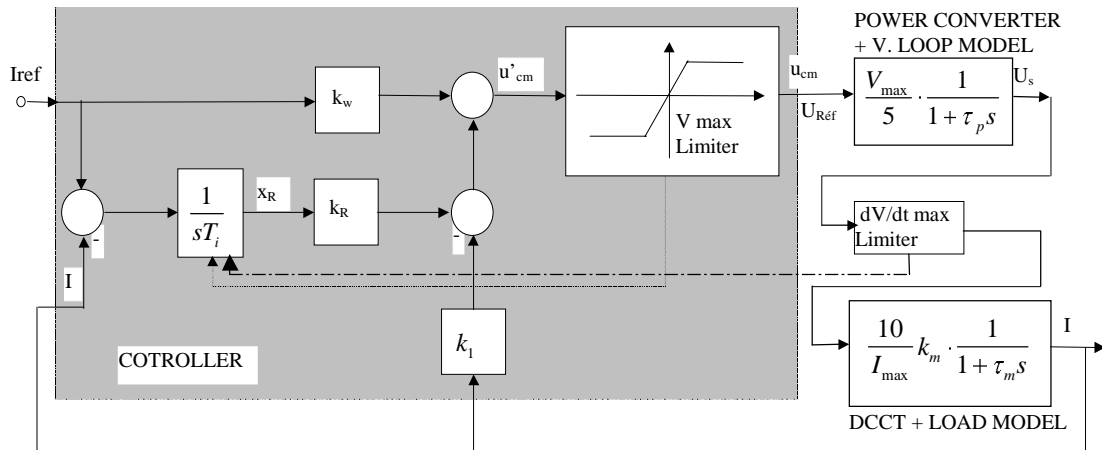

Figure 6: The current loop

Limiters

Active limiters are used to respect physical limits of the power converter. Without this respect, the controller will fall into saturation, thus losing control of the power converter and can lead to converter instability.

Vmax Limiter

This sub-circuit limits the reference signal of the voltage loop within the power converter voltage capability. In case of limitation, a signal is fed to the integrator to limit its output. When the limitation condition disappears, this signal returns to 0.

dV/dt Limiter

Because the rectifying bridge cannot change instantaneously from rectifier mode to inverter mode, it is necessary to limit the rate of change of the electronic damping loop input. This is equivalent to limiting the power converter output's rate of change. This limiter is also an active circuit, i.e. when limitation occurs a signal is fed to the integrator, limiting its output and thus avoiding loss of control.

The Loops Card

The analogue behavioural model, without limiting circuit, is given in figure 7. This system can be realised using op. amps and analogue multipliers. In a system where a parameter depends on the power converter characteristics or on the load, an analogue multiplier is used and a potentiometer is placed on a passive card called the "configurator" for adjustment purposes.

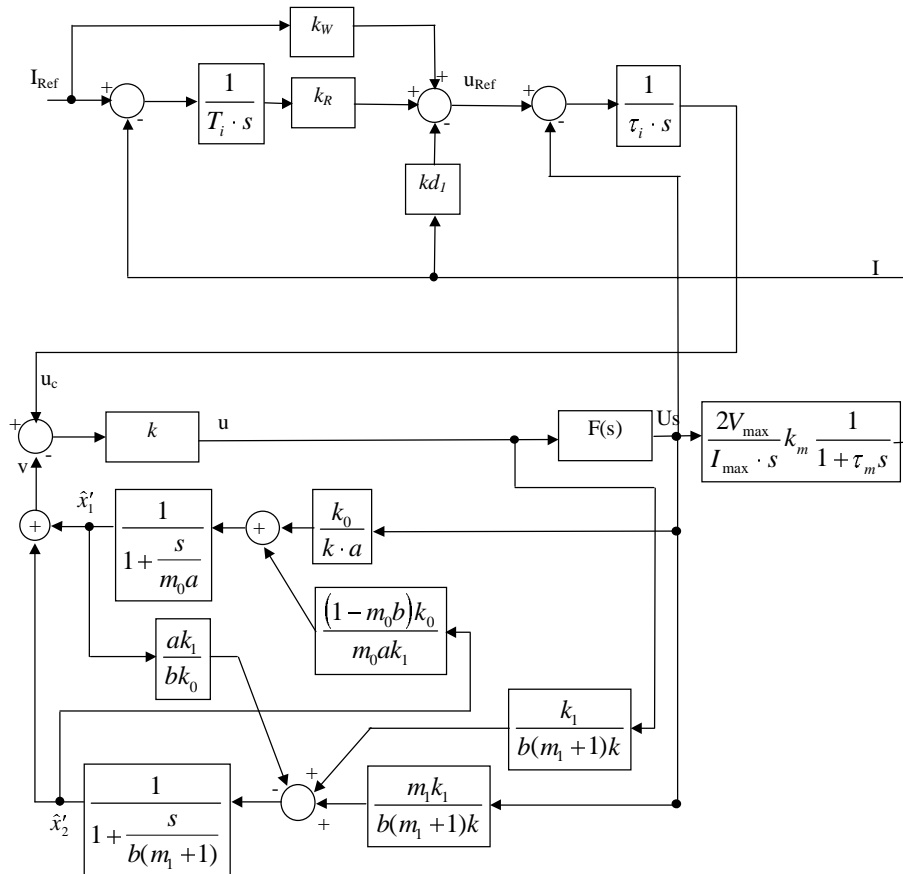

Figure 7 : Analogue behavioural model of the whole system

Results

Time Domain Response

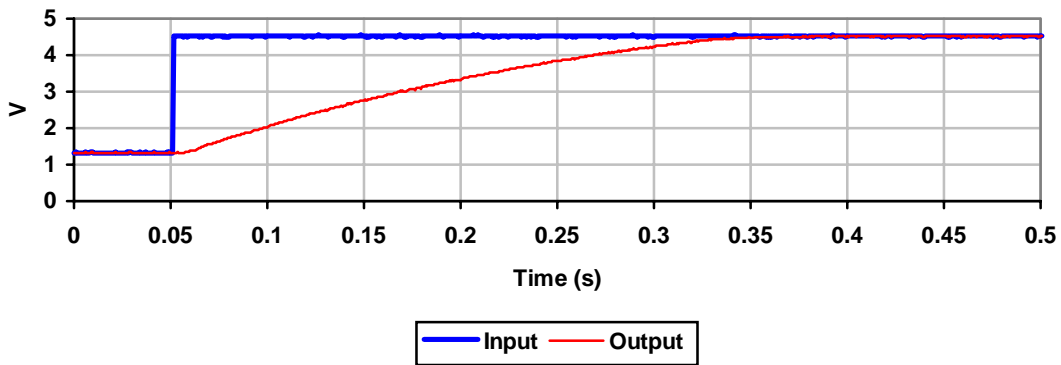

Figure 8 : Step response of the current loop

Frequency Domain Responses

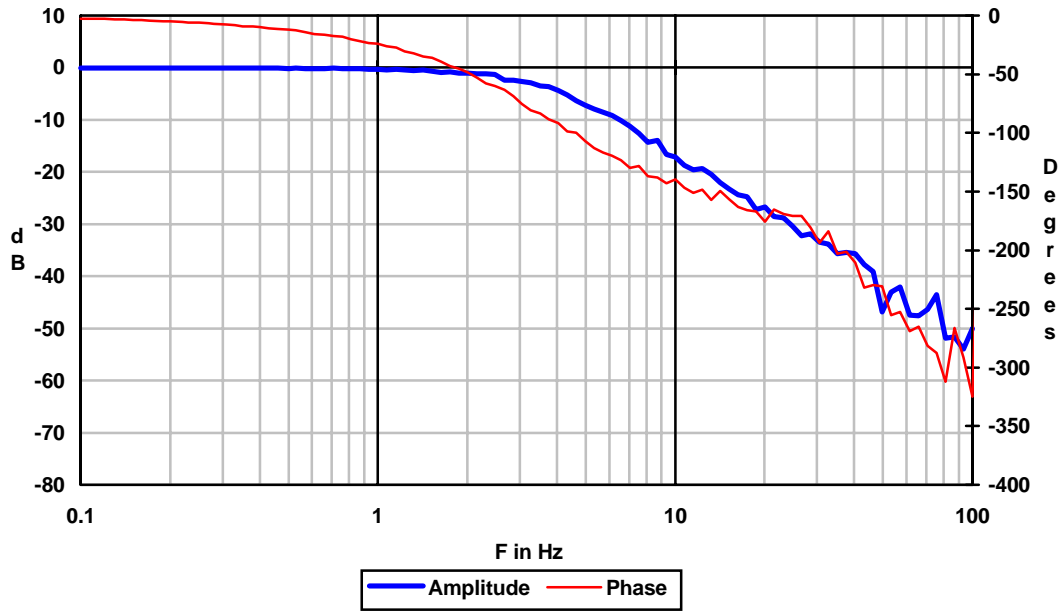

Figure 9 : Current loop response

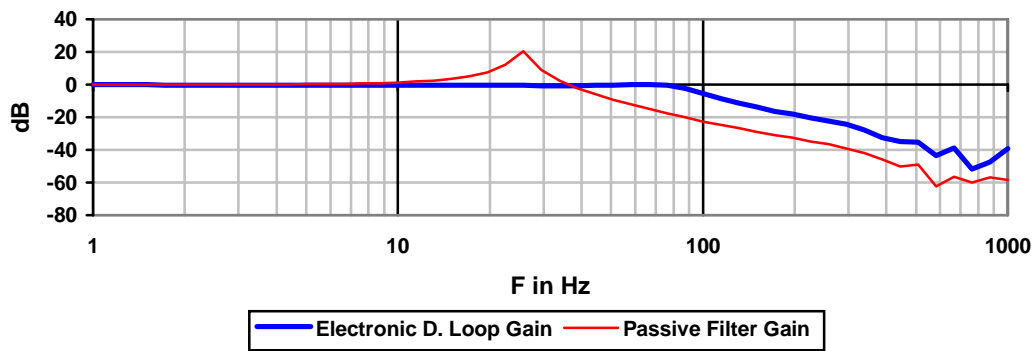

Figure 10 : Passive filter and electronic damping loop responses

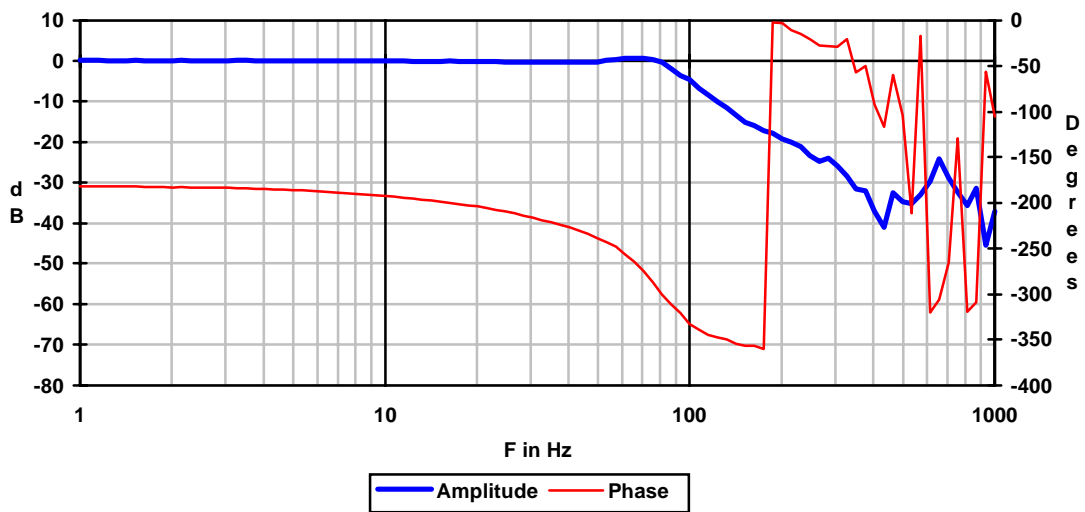

Figure 11 : Electronic damping loop response

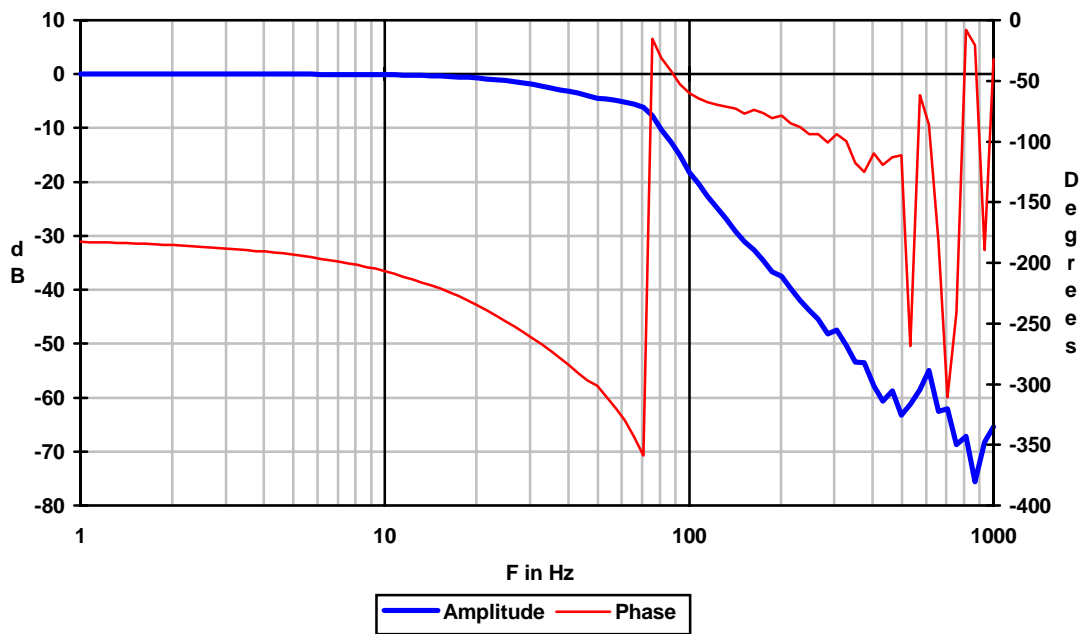

Figure 12 : Voltage loop response

Conclusion

As the loops card has all the adjustments placed on the configurator card, it is independent of the power converter and is thus interchangeable. Therefore, the maintenance is easy and could be done by non-specialist personnel. A completely parameterised control loop allows the change of the load parameters against the small penalty of voltage level adjustments.

The lightly damped passive filter has greatly reduced the output ripple. The modelling of the whole power converter would enable a rapid porting of the control loops into the digital domain.

Practical implementation of the control loop has pointed out the essential role of the active limiters, which keep the system under control (avoiding controller windup) when transients occur.

References

- B.C. Kuo** *Automatic control systems.*
Edition : Prentice Hall Collection : International Editions. Seventh Edition 1995.
- H. Bühler** *Conception de systèmes automatiques.*
Edition Presses Polytechniques et Universitaires Romandes. Collection électricité.
- E. Ozturk** *Commande de convertisseurs de puissance pulsés.*
Mémoire CNAM 1998.