

EUROPEAN ORGANIZATION FOR NUCLEAR RESEARCH  
CERN – SL DIVISION

CERN-SL-98-069 PO

**High-Current Performance Evaluation of DCCT's**

F. Bordry, G. Fernqvist, B. Halvarsson, J-C. Perréard, J. G. Pett

**Abstract**

The evaluation of high performance DCCT's to the ppm level has never been an easy task. With the LHC demanding currents up to 13 kA, a whole series of problems has arisen in the accurate measurement of these devices. In order to tackle these problems, new facilities have been designed for laboratory measurements under full power operating conditions. These include a high performance low voltage 20 kA power converter, quasi-coaxial bus-bar structures, Kusters Bridge range extenders and a novel bipolar 0 - 10 A current calibrator with resolution and linearity better than  $\pm 0.5$  ppm. This paper will present an overview of the complete facility and give more detail on the new current calibrator. Initial results will be presented, along with application areas which advance the state of the art in this field of measurements.

*EP<sup>2</sup> Forum, ESRF - Grenoble, France, 21-22 October 1998*

Geneva, Switzerland

01.12.98

# High-Current Performance Evaluation of DCCT's

F. Bordry, G. Fernqvist, B. Halvarsson, J-C. Perréard, J. G. Pett  
CERN, Geneva, Switzerland

## Introduction

The use of the zero-flux direct-current current-transformer (DCCT) to measure the output current of high performance power converters, such as those used in particle accelerators, is now almost mandatory. The operating principles are well known and described extensively in the literature [1]. The major sources of error are known and can be kept well below the 10 ppm level for currents in the range of 300 A to 3 kA. However, as current levels increase and particularly in the 10's of kA area, additional problems arise which have been extremely difficult to measure. As a consequence, performance improvements have proved all but impossible. With the completion of an extensive programme of study and the construction of a unique series of test facilities these barriers are largely removed. This opens the way to extend the measurement accuracy and hence overall power converter performance to the ppm level for output currents required for the LHC machine (13 kA).

## Major High-current Errors

As current level increases, the non-linearity of the DCCT can increase drastically. This is due to two major causes. The first is due to the asymmetric self-induced fields of the primary and return bus-bars, which can cause different depths of saturation in the cores, and hence disturbs the offset of the zero flux detector. Magnetic shielding can only reduce these effects to a certain extent. Such saturation results in output currents which are no longer accurately proportional to the turns ratio. The second is due to the power dissipation in the burden resistor. Both of these effects are known but cannot be easily separated by conventional measurements. The major problem for the user is that it is all but impossible to know that these effects exist, just by observing the output voltage. In fact, we know of no laboratory anywhere, including the National Standards Laboratories, which is able to measure currents above about 5 kA to an accuracy better than about 50 ppm in absolute terms. Any improvement in DCCT performance must therefore be based on accurate measurements of these two effects and careful evaluation of techniques to reduce each of them.

## Core Saturation

It is impractical to improve the magnetic shielding around the cores beyond a certain point and therefore the fields around the bus-bars must be improved. The most obvious method of reducing core saturation effects is to place the whole DCCT core assembly in a quasi-coaxial bus-bar structure. This then provides reduced radial field variations in the region where the cores are placed. A new test facility shown in Fig. 1 was therefore designed, which allows DCCTs to be placed easily within such a coaxial structure. Each coaxial bus-bar cell, namely the regulation, measurement and reference cells [2], can

be equipped with one or more DCCT core and coil assemblies. For the design current of 20 kA, this mechanical assembly is by no means simple but does allow for a whole variety of tests, including non-homogeneous radial fields, end effects etc. This test facility requires a low voltage 20 kA power converter [3], having both excellent stability and very low current ripple. A 20 kA inverting switch allows the current in the measurement and reference cells to be reversed.

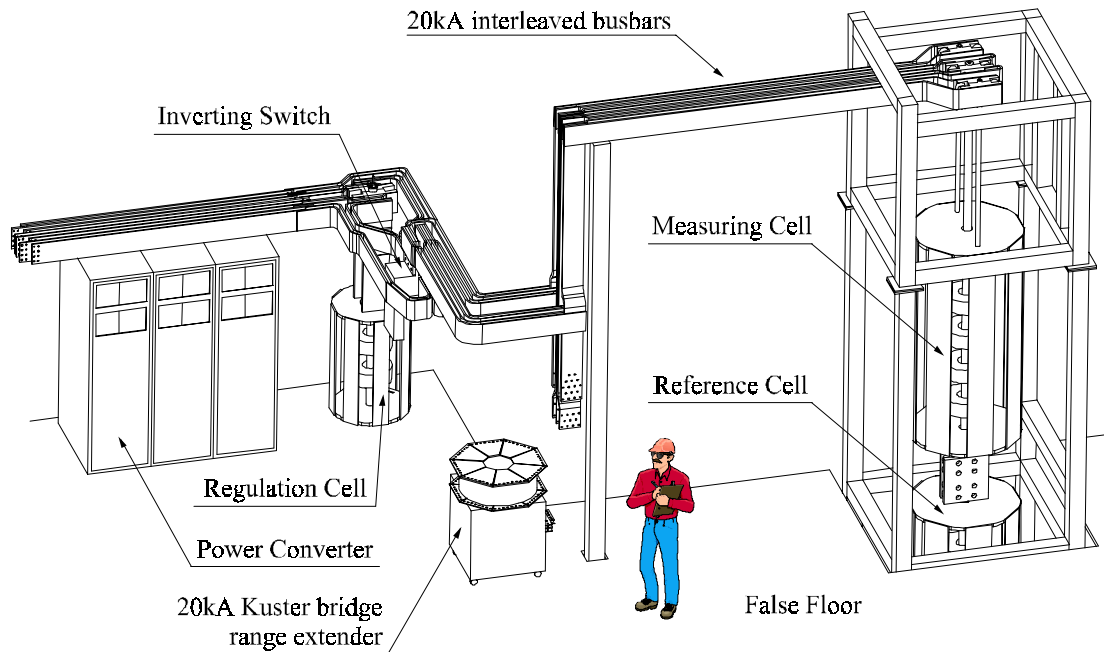

*NB: Cells contain DCCT coil assemblies*

Fig. 1 - New DCCT Test Facility

## Burden Resistor Dissipation

In order to translate the output current of the DCCT into a proportional voltage, an essentially perfect resistor is required. For low ohmic values a four terminal design is needed. Since there are practical limits on the turns ratio of a DCCT (about 1 : 7000), the dissipation in the burden increases with the primary current requirement. The ohmic value of the burden can only be reduced so far, otherwise the output voltage measurement itself presents difficulties. Since output voltages much below 1 V are not really practical, the dissipation in the burden would typically lie in the 2 to 3 W region for 13 kA DCCTs. Such resistors are very difficult to construct and even more difficult to measure at the ppm level. This is because such a measurement must be made under their real operating conditions, i.e. over the range of zero to about 3 W power dissipation. Precision resistors, used for accurate laboratory measurements, normally tolerate a maximum dissipation of 100 mW by comparison. A new current calibrator able to deliver very precise currents, in the range 0 to  $\pm 10$  A, has therefore been developed. The main aims of this work have been the precise measurement of DCCT output currents and the evaluation of burden resistors under true operating conditions. This latter measurement can be achieved by simply measuring the voltage across the burden resistor at

precisely known currents. This is now a possibility for the first time and thus allows both major DCCT error sources to be evaluated independently.

### The Current Calibrator

The new current calibrator consists of a special form of low current DCCT connected in a reverse configuration. This means that the input current is stepped up rather than down, which is the more normal usage for a DCCT. A simplified schematic diagram is shown in Fig. 2. A very precise current (10 mA) is injected into a series of 12 primary windings, having a binary increase in the number of turns (1..2048, + 1 extra single turn). The secondary high-current windings consists of a smaller number of windings, such that the total number of turns (4..40 turns) can be varied to produce a maximum output current of 10 A. A single extra primary turn allows a fractional current to be injected, such that an overall resolution of about 26 bits can be obtained. This fractional current is obtained from a 16 bit DAC.

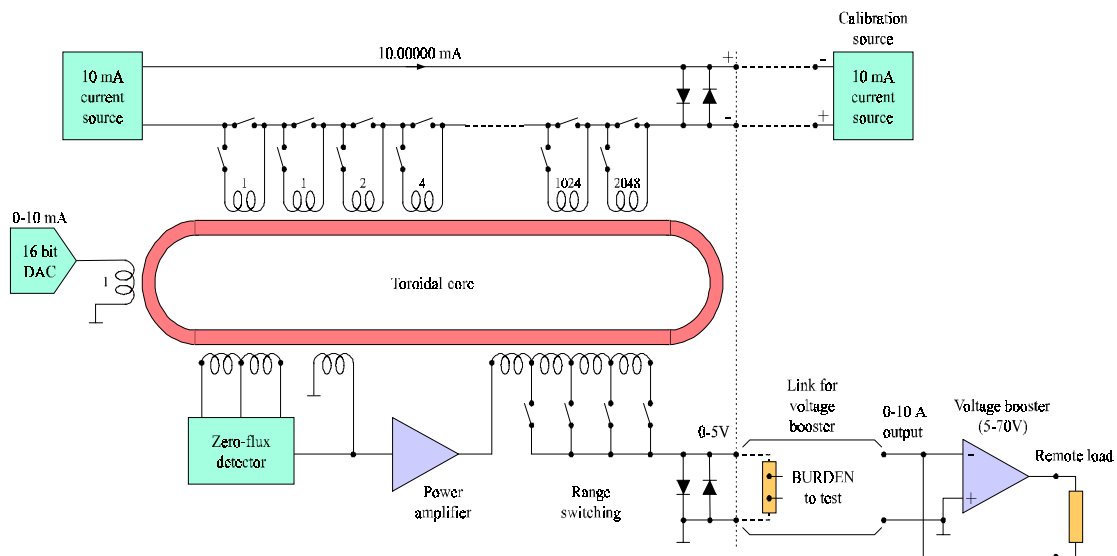

Fig. 2 - Basic Current Calibrator

The cores are operated at a maximum of only 40 At excitation and hence the stability of the zero flux detector and the remanence of the cores is of prime importance. Therefore, all environmental effects, which would normally have only a small influence for a higher current DCCT, have had to be taken into account. Careful thermal design, magnetic screening and a revision of the high-frequency modulator have largely eliminated these effects. With careful operation, including a rapid 'degaussing' procedure after switch-on, the offset errors can be held below 0.2 ppm of full-scale range.

Each primary winding is equipped with a reversing switch (not shown in Fig. 2), as well as the basic switch to include (or not) the associated winding. Using the additional single turn, this allows the low turn windings to be successively added in, in opposition to the next larger winding, such that the zero flux detector can measure any imbalance between all operational windings. This is a very powerful check on the whole system and allows cross comparison between all system components in an identical manner to the famous Kusters

Bridge [4]. Turns ratio accuracy is thus observable to the 0.2 ppm level and has always been essentially perfect. This method ensures linearity for the major bits and a similar build-up method is used for the DAC driven winding. Hence, the system performance can be set up and reconfirmed at any time to be within the limit set by the zero flux detector.

The internal power amplifier can source  $\pm 10$  A but due to dissipation restrictions cannot provide more than a few volts ( $\pm 5$  V), to an external device. In general this will not be a serious limitation for most measurements. However for driving external loads, such as calibration windings, an additional voltage booster must be employed. In this case, the external power amplifier provides the additional voltage (at the set current from the basic current calibrator) while maintaining the summing junction, at its input, at zero volts. Leakage currents and input bias currents must naturally be maintained below the expected performance in this mode of operation.

As stated above, the primary reference is a 10 mA constant current source. While this has been designed to be extremely stable it will need re-calibration at regular intervals. In the measurement laboratory this does not present any particular problem as the 10 mA can be passed through a known standard resistance and the resulting voltage measured. Use of the current calibrator in a remote location will involve re-calibration via a second mobile 10 mA reference source, which can be connected in opposition to the unit to be calibrated, as shown in Fig 2. Adjustment of the unit to calibrate, until the output voltage is precisely zero, will then ensure that the output current is equal to the mobile standard. This should prove to be an extremely simple task, as no lead resistance or thermal voltage problems exist, as is the case with comparing voltage sources.

## Test Methods and Results

A large number of tests have confirmed the basic accuracy of the current calibrator, including the turns ratio accuracy and linearity of the core assembly methods mentioned earlier. Furthermore, comparison with the Kusters Bridge has provided additional proof of overall performance. From these evaluations, we can state that the prototype current calibrator can provide a variable current over the range -10 to +10 A, with a setting accuracy of 0.2 ppm of 10 A. The resolution, while limited by the low frequency noise, is approximately 26 bits. Long-term drift appears to be extremely small, but awaits the construction of a second prototype using an improved 10 mA source.

Since the complete current calibrator acts as an essentially perfect **current source** the simple test set-up for burden resistor evaluation, shown in Fig 3, has allowed detailed investigation of this critical component to be started. The burden can now be measured over the expected operating current range for stability, reproducibility, non-linearity and absolute value etc. Results to date are most interesting, with measurement uncertainty close to the 1 ppm level. A number of resistors have been measured with quite unexpected results. The effects of power dissipation generally result in a non-linear resistance change, as could be expected. However, there can also be a substantial overall change in the resistive value with current, due to effects such as mechanical strain.

This work is only at an early stage but it should now be possible to characterise burden resistors quite easily and hopefully to improve their performance over the long term.

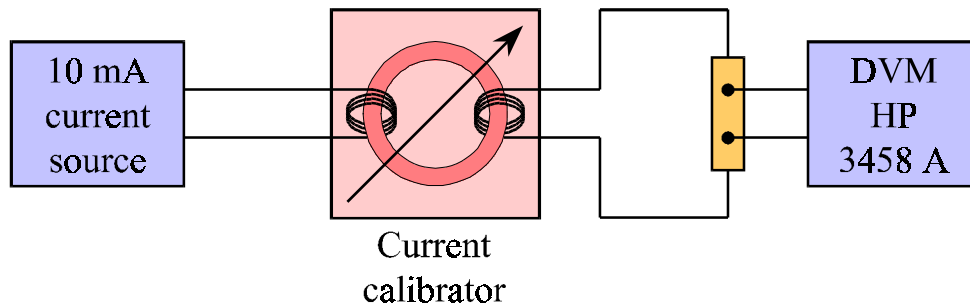

Fig. 3 - Burden Resistor Measurement

Using the current calibrator to absorb the output current from a DCCT under test in the facility shown in Fig. 1, will allow accurate measurement of the core assembly alone. This will involve a more complicated series of inter-comparisons with the Kusters bridge or reference DCCTs. Non-linearity effects can be measured by distorting the field around the DCCT core. This can be achieved by removing bus-bars in the quasi-coaxial cell and measuring the actual field levels with a flux meter. Initial trials of these techniques are now underway, along with in-situ calibration methods and are showing excellent results. Many more evaluations will be needed before the complete range of tests envisaged can be reported, however, with the completion of this unique test and measurement facility, such tests can now be started.

### In-situ Calibration

Due to the large size of the site and the underground installations required for the LHC machine, removal and laboratory re-calibration of high current DCCTs would be highly impractical. Additionally, for any high current DCCT, the removal of the core assembly from a large bus-bar structure would be extremely tedious and subject to alignment errors upon re-assembly.

A method, suggested by the authors, to provide in-situ calibration of the complete operational current measuring system for LHC is shown in Fig. 4. The power converters are shown as a power part and an associated converter control part. For LHC, an all-digital regulation has been chosen rather than the traditional analogue method. The current measuring system consists of a dual DCCT plus ADC combination, which delivers digital values of the output current to the regulation and control part. The DCCT plus ADC is duplicated for reliability and performance verification reasons.

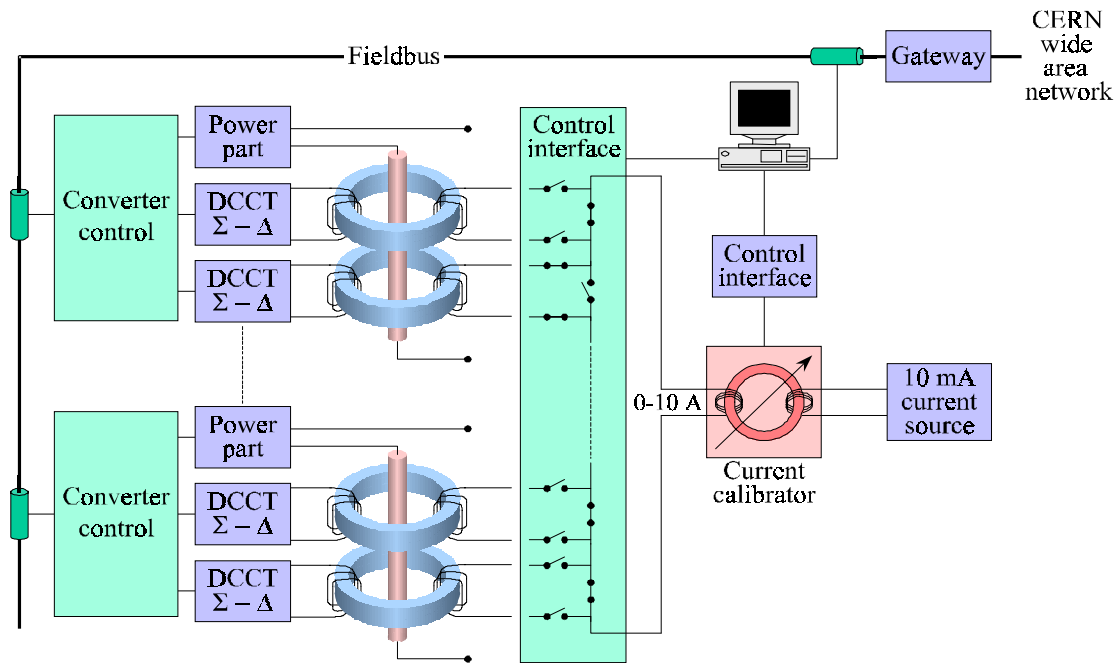

Fig. 4 - In-situ Calibration

On each DCCT core assembly an additional winding allows calibration currents to be injected from the current calibrator. A switching matrix allows one or more calibration windings to be selected. This matrix and the whole of the current calibrator system are connected to the controls network, thus providing remote re-calibration possibilities. To perform a calibration, the power converter output current must be zero, i.e. the power part must be off and the load current must have decayed completely. The current calibrator can then pass a precise current through the calibration winding(s) thus creating a known number of ampere-turns, equivalent to that created by the central bus-bar during normal converter operation. The whole range of excitation can be covered, up to the maximum level at which the DCCT will operate. The resulting digital values from the ADC will be recorded for each set value and a corresponding digital calibration constant calculated. In this way all sources of static error due to the DCCT cores, burden and ADC can be calibrated out, including total offset, linearity and full scale gain values. Other possibilities for checking operational values, using only one DCCT, could also be possible.

This approach will allow quite frequent re-calibration should it prove necessary, since the time required can be reduced to a few minutes per converter. Equally, the method should ensure much more accurate calibration, as no mechanical work or reconfiguration of the system components will be necessary.

### Concluding Comments

The new facilities and novel methods proposed in this paper have allowed improved measurements of high current DCCTs (> 10 kA), to be made for the first time. Initial results have been obtained which are encouraging. To our knowledge this is the first time that such measurements approach the ppm level in absolute terms. This will allow improved current measuring devices and

techniques to be developed and employed. As a consequence, the performance requirements of the LHC machine now seem to be achievable. For the current calibrator, a computer-controlled version is now under development. Confidence in the new facilities will require an extended period of use and improvements may well be needed in a number of areas before results can be published.

## References

- [1] Proceedings of the CERN Accelerator School on Power Converters for Particle Accelerators, March 1990.
- [2] Design and verification of a 24 kA calibration head for a DCCT test facility, G. Fernqvist, H-E Jorgensen, A. Saab ; CPEM'98 Conference, Washington.
- [3] High current, low voltage power converter [20 kA, 6 V] LHC converter prototype, H-E Jorgensen, F.Bordry, A. Dupaquier, G. Fernqvist ; EPAC'98 conference, Stockholm.
- [4] A current comparator for the precise measurement of d.c. ratios, N. L. Kusters et al, IEEE Transactions on Communications and Electronics, vol. 83, Jan. 1964, pp 22-27.