

From Narrow to Wide Band Normalization for Orbit and Trajectory Measurements

Daniel Cocq, Giuseppe Vismara

Abstract

The beam orbit measurement (BOM) of the LEP collider makes use of a narrow band normalizer (NBN) based on a phase processing system. This design has been working fully satisfactory in LEP for almost 10 years. Development work for the LHC, requiring beam acquisitions every 25 ns, has led to a new idea of a so-called "Wide Band Normaliser" (WBN) which exploits most of the P.U.'s differentiated pulse spectrum. In the WBN the beam position information is converted into a time difference between the zero crossing of two recombined and shaped electrode signals. A prototype based on the existing NBN unit has been developed and tested to prove the feasibility of this new idea. For this the B.P. filters and the 90° hybrids are replaced by L.P. filters and delay lines.

Presented at BIW-98, 8th Beam Instrumentation Workshop
SLAC, USA
4-7 May 1998

Geneva, Switzerland

From Narrow to Wide Band Normalization for Orbit and Trajectory Measurements

Daniel Cocq, Giuseppe Vismara

CERN, Geneva, Switzerland

The beam orbit measurement (BOM) of the LEP collider makes use of a narrow band normalizer (NBN) based on a phase processing system. This design has been working fully satisfactory in LEP for almost 10 years. Development work for the LHC, requiring beam acquisitions every 25 ns, has led to a new idea of a so-called "Wide Band Normaliser" (WBN) which exploits most of the P.U.'s differentiated pulse spectrum. In the WBN the beam position information is converted into a time difference between the zero crossing of two recombined and shaped electrode signals. A prototype based on the existing NBN unit has been developed and tested to prove the feasibility of this new idea. For this the B.P. filters and the 90° hybrids are replaced by L.P. filters and delay lines.

INTRODUCTION

The beam position measurements have greatly evolved in the last few years with demands for better performances on both dynamic range and bunch to bunch time resolution (< microsecond). Since the number of BPMs is increasing with the dimensions of the machines and the spacing among bunches gets smaller, acquisition systems become very complex and expensive, unless a normalization process is employed.

A normalization process will produce the analog ratio Δ/Σ required for the position measurement, which largely simplifies the digitization process. The Beam Orbit Measurement (BOM) [1] of the LEP accelerator is a good example of a normalization process based on the "Phase Normalization" principle, associated with an 8 bit FADC.

The main advantages of this technique are:

- Normalization using only passive components
- Wide dynamic range (>50 dB) on the input signal without gain change
- 10 dB compression of the position dynamic for 1/3 of the normalized aperture
- Higher sensitivity for centered beam, due to the ATAN transfer function
- Reduction by a factor two of the number of digitization channels
- Simplicity and reliability
- Low cost electronics

The limiting point of this system concerns the minimum bunch spacing (>100 ns) due to the restricted bandwidth of the resonant filter, the 90° Hybrid and the settling time of the

transmission path. In order to reduce the digitization time (25 ns for LHC) one has to increase the transfer function bandwidth from the filter up to the ADC. In the framework for the LHC development, a new normalization idea called "wide band normalizer" [2] (WBN) has emerged. The idea is based on an evolution of the "phase normalizer" principle where the "phase" is replaced by the "time" and the applied signal has a single oscillation period.

FROM NARROW (PHASE) TO WIDE (TIME) BAND NORMALIZATION PRINCIPLE

The position measurement is determined by the normalized difference of signals on opposite electrodes

$$\text{Position} = K_x * (V_a - V_b) / (V_a + V_b) = K_x * \Delta / \Sigma = K_x * CR$$

where $CR = \Delta/\Sigma$ is the normalization and K_x is the scale coefficient.

In the phase normalization [3] (Fig. 1) the two electrode signals are applied, after proper filtering, to the inputs of a 90° Hybrid. Each signal is shifted by 90° and then added to the opposite in-phase signal. The resulting phase difference (Φ) of the two outputs corresponds to their normalization

$$\Phi = \text{Arc-tangent} (V_a / V_b)$$

This relation is valid for a continuous wave or a single oscillation period after proper settling time, which depends on the bandwidth of the processing chain. For a fixed frequency f_0 , the 90° phase shift phase can be realized by delaying (in the time domain) the signals using $\lambda_0/4$ length coaxial cables [4]. Since all components are wide band there is no difference between a repetitive signal and a single oscillation (or a bipolar pulse). Fig. 2 shows the block diagram of a delay normalizer.

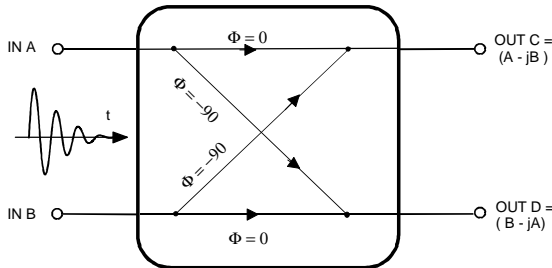

FIGURE 1. Phase Normalizer schematics

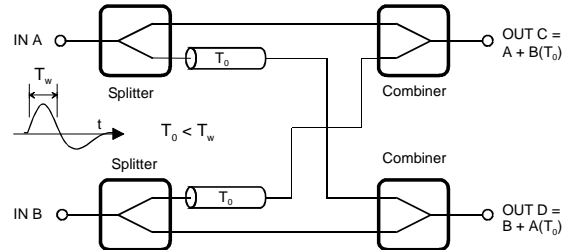

FIGURE 2. Time Normalizer schematics

The induced signals on the button pick-up are differentiated by the electrode capacitance and the resulting signal is a bipolar pulse (Fig. 4). For simplification let us assume a linear pick-up. Under this assumption the sum of the electrode signals is therefore constant with respect to the position. The signals from both electrodes of a plane are split in two and one branch is delayed by the time T_0 . The delayed signal of one channel is then added to the direct signal of the other channel, and vice versa.

At output C, the time of passage through zero can vary up to a maximum of T_0 depending on the relationship of the amplitudes on the pick-up. At output D, the same

variation can be observed but in the opposite sense (Fig. 3 right) hence the maximum relative variation between C and D is therefore $2T_0$. The transfer function, measured as the Δt between the two outputs for the negative zeros crossing, is almost linear and the sensitivity is proportional to the delay. In the example described, T_0 is fixed at 1.5 ns but can be any value shorter than the signal width T_w . When approaching T_w the transfer function gets more and more distorted and is not exploitable anymore.

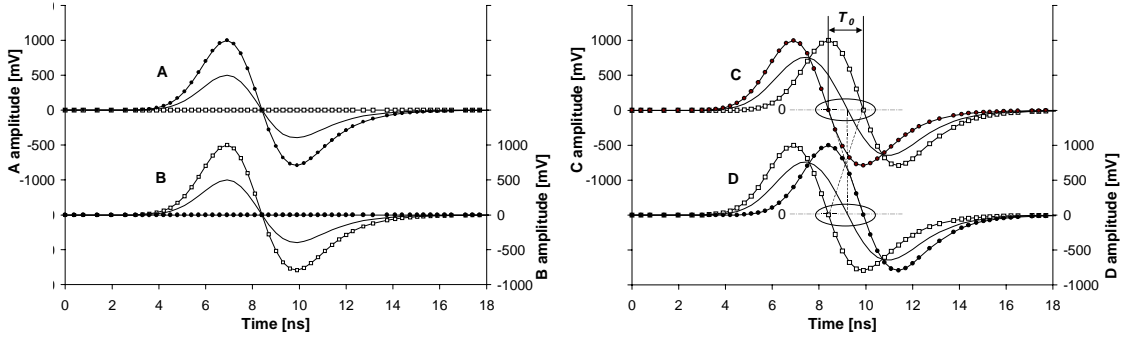

FIGURE 3. Signals at Normalizer inputs (left) and outputs (right) for three different beam positions

Two fast comparators detect the zero passage and activate a flip-flop that generates a pulse T_{out} where the width will vary up to $2T_0$. By integrating this pulse, the time variation is transformed into amplitude and can be read by an A/D converter. As has been shown this solution offers all the prerogatives of the phase normalization and extends the bandwidth of the transfer function by at least one order of magnitude.

SIGNAL ANALYSIS

The following considerations are general but examples are related to the LHC applications. The induced signal has a Gaussian distribution and the pulse width can change during the accelerating cycle. For the LHC it varies from 1.0 to 0.5 ns and the Fourier transformation shows the content difference of the two spectrums (Fig. 4A).

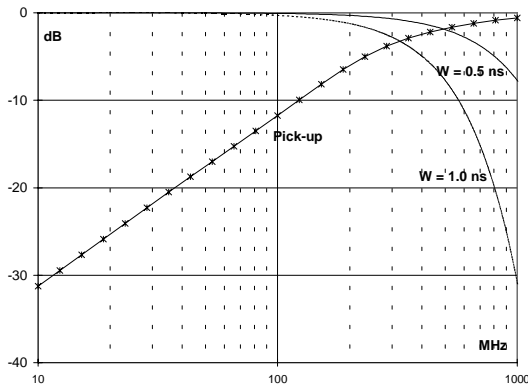

FIGURE 4A. Frequency spectrum & PU response

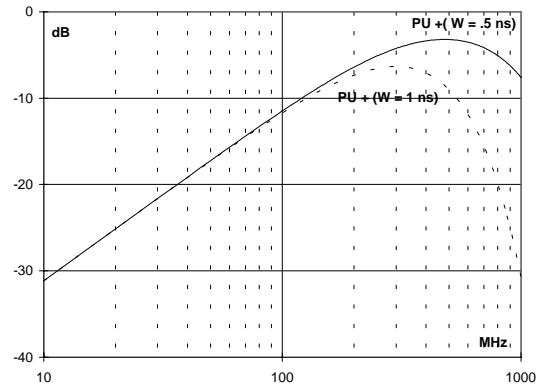

FIGURE 4B. Pick-up output spectrum content

The capacitive monitors (buttons, couplers, etc.) have, by definition, a low frequency cut-off which is determined by the geometrical dimensions and the resistive load.

The LHC buttons show a 397 MHz low frequency cut-off and the estimated high frequency cut-off is over 3 GHz (Fig. 4A "Pick-up"). When combining the beam spectrum content and the button response, the output signal has a response similar to a band-pass filter, as can be seen in Fig. 4B. As a consequence all induced signals will be differentiated and the average value is zero; all processing chains are submitted to these restrictions. The transmission path between the electrode and the signal treatment unit should be free of reflections for a correct measurement and to avoid false triggering; an acceptable figure but quite difficult to obtain would be $\approx 1\%$ (40 dB). The interconnecting cables should have a length such that the reflection comes after the measurement instant and before the next pulse. For the LHC application, cable lengths between 5 to 10 ns will be used. The filter at the receiving end should be matched over the whole frequency spectrum.

LOW-PASS FILTER

In order to obtain an output signal shape independent of the beam dimensions, the high frequencies should be limited to a value where the spectrum content does not vary. For easy signal treatment the pulse response should correspond to a bipolar pulse of a single oscillation having the most symmetric amplitudes.

Choice of the cut-off frequency

Several contradictory criteria should be taken in account:

1. The output pulse shape is to be independent of the pulse length. For the LHC beam it corresponds to < 210 MHz for a signal amplitude difference smaller than $< 10\%$.
2. The minimum pulse length to obtain a good S/N ratio and a linear transfer function, which can easily be handled by the active electronics. Since a logic (ECL lite) time jitter is ≈ 3 ps rms. a minimum full-scale time excursion of 3 ns is required, when using a 10 bit digitizer. This requires a 1.5 ns delay line which implies that the output spectrum central frequency ($f_0=4/T_0$) should not exceed 166 MHz.
3. The maximum pulse duration for unaffected double pulse measurement. The BW and more strongly the filter response determine the residual amplitude. Gaussian or Linear phase filter are recommended. The LHC specifications ask for residual amplitude of $< 0.2\%$ for a bunch spacing of 25 ns.

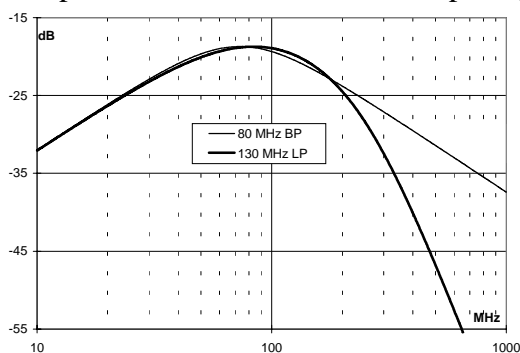

FIGURE 5. Filters frequency response

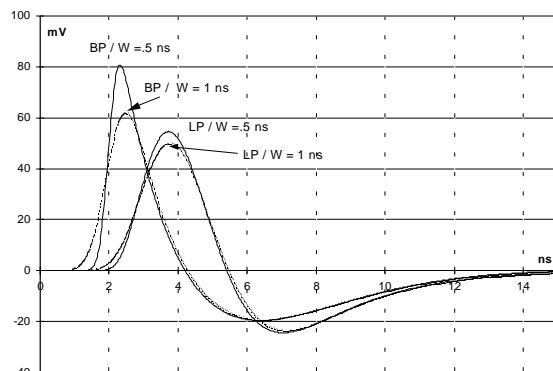

FIGURE 6. Pulse response for a pilot bunch

Filter

The simplest filter that can be implemented is a single resonator, which can be realized by simply adding a serial inductance on the button (Fig. 5 - 80 MHz BP). However such a scheme does not filter properly the high frequency spectrum contribution. The result is an asymmetric bipolar pulse which still depends on the pulse length (Fig. 6 - BP/W=0.5/1.0 ns). The best compromise is to add a Gaussian low pass filter to cut the high frequency sharply. The global transfer function still has the same central frequency (≈ 80 MHz), while the LP filter is computed for 130 MHz (Fig. 5 - 130 MHz LP). The global bandwidth corresponding to >120 MHz. The amplitude gets lower ($\approx 20\%$) but the pulse symmetry and the variations versus beam dimensions are much better ($\Delta V_+ < 10\%$) (Fig. 6 - LP/W=0.5/1 ns).

NORMALIZATION

While keeping the same normalization principle a simplified version making use of an inverter transformer (Fig. 7) has been developed for the realization of the prototype. One of the two input signals is delayed by T_0 , inverted and applied to the two negative inputs of a dual differential amplifier. The second one is directly applied to one of the positive inputs, then delayed by $2T_0$ and applied to the second positive input. The resulting output signal from the amplifier is the same as for the original idea but the signal has twice the amplitude.

Since the delay T_0 can be part of the interconnection cable and the dual amplifier is an integral part of the comparator circuit, the normalizer components are reduced to an inverter transformer and a coaxial cable ($2T_0$).

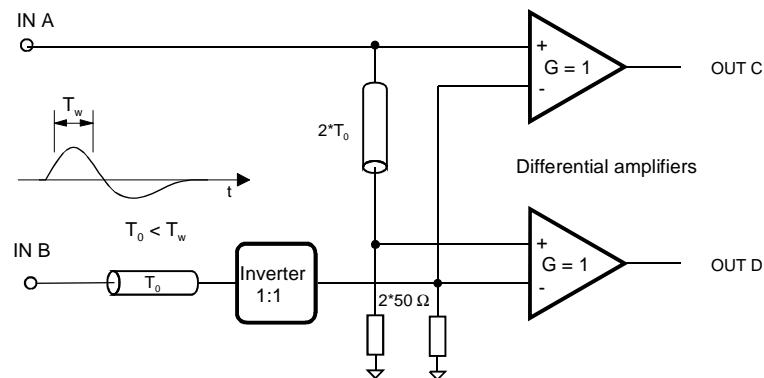

FIGURE 7. Inverter Normalizer

ZERO-CROSSING DETECTOR

A dual ultra-fast comparator (AD96687) like for the BOM NB acquisition system provides the zero-crossing action. The input stage is a differential amplifier and it realizes part of the normalization action (recombination of the delayed signals). The latch inputs are biased to generate a small hysteresis (10 mV) which will determine the threshold of the comparator. Since the comparator gain is over 60 dB, a positive-going

signal above 10 mV will switch the output of the comparator to its high state.

The input offset is trimmed to bias the comparator just at the lower edge of the hysteresis cycle, in order to obtain a real zero-crossing and to be totally independent of the amplitude. The output pulse length depends on the selected LP filter frequency and on the input signal ratio. In the LHC development it varies from 3 to 5 ns.

The useful input dynamic range is >50 dB, and corresponds to the ratio between the maximum differential input (>3 V) and the threshold (10 mV). The comparator input noise is $3 \text{ nV}/\sqrt{f}$ over a bandwidth >200 MHz, which results in a total input noise of $50 \text{ } \mu\text{V}$ (rms.). The signal to noise ratio (S/N) corresponding to the pilot beam is >46 dB.

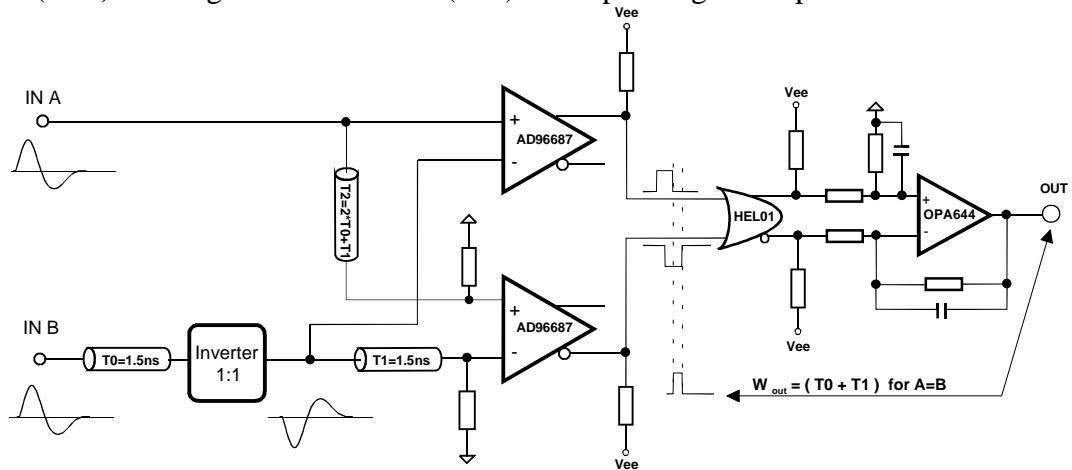

FIGURE 8. Wide Band Normalizer block diagram

The propagation delay is the most critical point, since it depends on the signal overdrive and can vary up to 1 ns. It is very important that the tracking between channels is similar; previous experience has shown an average figure of 30 ps per 40 dB dynamic, which corresponds to an error of 1% of the full scale. Most of this error is present on the first 6 dB overdrive from threshold.

PRESENT STUDIES ON DIGITIZATION

The position information is the time difference between the trailing edges of the two-comparator outputs. A simple NOR function of the comparators Out1 and the complementary Out2 ($\overline{Out2}$) signals produces an output pulse width equal to the time difference. To avoid non-linearity problems due to overlapping of signal transitions the minimum pulse width should be ~ 1.5 ns. This is obtained by inserting a coaxial line between the two comparator inverting inputs and adding an extra 1.5 ns on the other branch. The NOR output pulse width will range from 1.5 ns up to 4.5 ns. Since it is difficult to digitize a time of a few ns with a resolution in the picosecond range, the NOR output pulse charge is digitized instead. To keep the circuit as simple as possible the two outputs are filtered by a 50 MHz Gaussian low-pass filter and applied to a video amplifier-buffer. The signal present at the ADC input will vary both in amplitude and time.

Two digitizing solutions have been explored:

a) Low resolution (8 bit) and high sampling rate (>500MS/s) FADC.

A minimum of 12 samples per measurement is taken in a window synchronous with the PU signal. The data is averaged to improve the resolution by a factor 3 to 4 according to the sampling rate. It requires ultra fast FADC and RAM, and a fast processor to treat the data. The clock can be synchronous with the signal, which offers a stable data acquisition and linearity $<\pm 0.1\%$ or asynchronous with data deviation $<\pm 0.1\%$ and excellent linearity. This solution is quite complex and expensive.

b) High resolution (10 bit) and moderate sampling rate (>40 MS/s) ADC.

The ADC sampling time should be fixed relative to the PU signal and delayed by ~ 1 ns after the pulse peak. The amplitude varies as function of the delay hence a calibration is required. The aperture uncertainty for a 10 bit ADC should be <10 ps in order to keep at least 9 ENB. Under these conditions the linearity error is $\approx \pm 1\%$. This figure can be improved by a factor x5 using a polynomial fit.

Both solutions require deeper investigation but the results are very promising.

MEASUREMENTS

Since the phase and time normalizer concepts are quite similar and they require the same basic components, it has been quite simple to adapt an existing BOM NB normalizer circuit to the WB version.

The LP 130 MHz circuit has replaced the BOM 70 MHz BP filter. On the normalizer unit, the inverter transformer and the delay cable have replaced the 90° Hybrid. On the "zero crossing detector and the TAC" hybrid, a pin to pin compatible OR chip has replaced the Ex-OR. The video LP filter is set to 50 MHz instead of 20 MHz and the video amplifier replaced by a faster and pin to pin compatible OPA644.

Set-up:

A bipolar signal filtered at 130 MHz is applied to a common attenuator (employed for stability measurements), split into two branches by a 0° Hybrid and applied to the unit under test via two high-resolution (0.25 dB) attenuators. The attenuators have been measured for a propagation delay difference $<\pm 10$ ps and an attenuation accuracy inside two parts per thousand. From the attenuation ratio between the two branches (A/B) we obtain the normalized ratio $CR = (1-A/B)/(1+A/B)$. The measurements are done with a digital oscilloscope sampling at 1GS/s in a 20 ns window.

Output Stability versus input level:

The variation on the output signal for different common attenuator values is normalized to the full-scale aperture. The measurement has been done for 3 different conditions corresponding to a centered beam and two symmetric offset positions. From twice the threshold level up to 45 dB overdrive, the normalized output stays within $\pm 1\%$ of the full aperture.

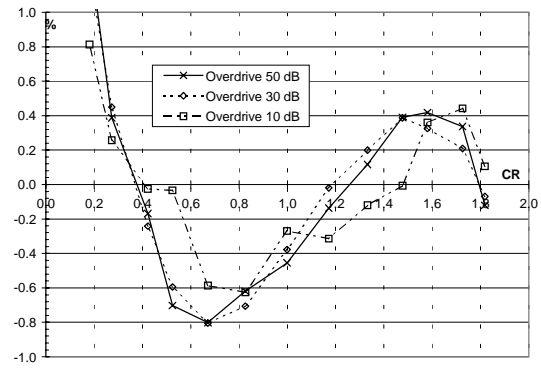
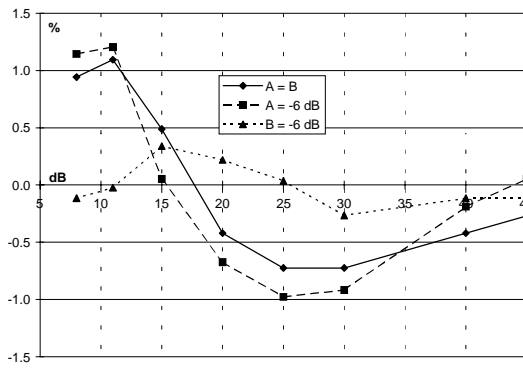

FIGURE 9. Normalized out variation vs. overdrive

FIGURE 10. Linearity errors at different overdrive

Linearity:

Figure 10 shows the linearity errors relative to a straight line versus the normalized aperture (over 80% range) for different overdrives above the comparator threshold.

The 10 dB overdrive corresponds roughly to the pilot beam and its slope is 3% less sensitive than the average. From 20 up to 50 dB overdrive the sensitivity remains constant within a fraction of one percent. The sigma of the linearity error is <0.6% and is repetitive at different input levels. A second order polynomial fit will reduce the sigma error to the range of 0.1%.

Noise:

Figure 11 shows the sigma of the output signal, normalized to the full-scale aperture versus the input signal overdrive. A pilot beam corresponds to a +10 dB overdrive.

The measurement has been done for a centered beam (A=B) and for an offset beam (B=-25 dB of A).

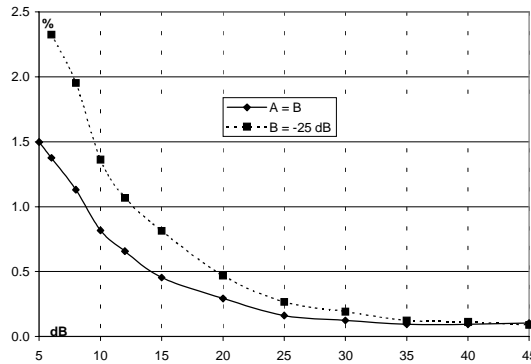

FIGURE 11. Normalized Noise vs. input level above threshold

EXTENDED APPLICATIONS

The principle can be extended to a wide variety of beam length and pick-up types by properly filtering the induced signals and scaling the delay lines. A beam length ratio up to a factor 10 seems to be easily attainable. The coupler electrodes associated to a proper

LP filter can also be used, therefore taking advantage of their larger sensitivity.

For particle accelerators having a large signal length variation during the acceleration cycle or for accelerator bunches with different length (i.e. transfer lines PS to SPS), the LP filter and the cable delay should be designed to work properly for the longest bunch.

A general circuit that could be exploited by a large number of particle accelerators should be designed to have removable coaxial delay and a large set of Gaussian LP filters. If wide band requirements are not needed, integration over long time periods can be simply obtained by increasing the output filter time constant.

CONCLUSIONS

The prototype performances fully satisfy the LHC specifications.

The building blocks of this system are identical to the LEP NB normalizer where 500 BPMs have been operating for almost 10 years with an excellent reliability and requiring a minimum number of human interventions. This expertise will facilitate the LHC development and avoid basic errors.

The WB normalizer solution offers all the advantages reported for the NB normalizer. Furthermore the realization of the LP filter requires less critically matched-paired units. The simplicity of the electronics, the reduced number of digitization channels associated with the reliability and the low cost per channel make the WBN solution ideal for many BPM acquisition systems.

ACKNOWLEDGEMENTS

We would like to thank Dr. Hermann Schmickler for his invaluable contribution and support during the development. Special thanks go to Mr. Jean-Luc Pasquet for the realization of the prototype and part of the tests.

REFERENCES

- [1] J. Borer, D. Cocq "The second generation of optimized Beam Orbit Measurement (BOM) system of LEP: Hardware and performance description" CERN-SL-95-60 BI Paper presented at DIPAC'95 - 2nd European Workshop on Beam Diagnostics and Instrumentation for Particle Accelerators 28–31 May 1995.
- [2] D. Cocq "The Wide Band Normalizer - a new circuit to measure transverse bunch position in accelerators and colliders" CERN-SL-97-74 BI submitted and accepted by NIM.
- [3] R.E. Shafer, R.C. Webber et al. "An rf beam position measurement module for the Fermilab energy doubler" IEEE transactions on nuclear science, Vol. NS-28, No.3, June 1981 page 2323.
- [4] R.E. Shafer, "A large dynamic range amplitude comparator" RF digital connection September 1986 page 74.