

**EUROPEAN ORGANIZATION FOR NUCLEAR RESEARCH**

**CERN — SL Division**

**CERN-SL-98-066 RF**

**THE LEP SUPERCONDUCTING RF SYSTEM:  
CHARACTERISTICS AND OPERATIONAL EXPERIENCE**

**D. Boussard and E. Chiaveri**

**Abstract**

The Large Electron Positron Collider (LEP), the largest accelerator in the world, is equipped with a superconducting RF system designed at CERN and constructed by European industry. The energy radiated by the circulating beams via synchrotron radiation is replenished by the RF system, which provides a total accelerating voltage of about 3 GV. Very large continuous RF power is thus transferred to the beam; in routine operation it amounts to more than 13 MW at a total beam current of 6 mA. The cryogenic installation, one of the largest in the accelerator world, delivers 48 kW at 4.5 K to keep the cavities superconducting. This paper describes the overall RF system, putting emphasis on the design choices and on the problems encountered during their implementation. It also reports on the operational experience with this system, showing that its reliability and performance has enabled LEP to largely exceed the goals set a few years ago.

Presented at  
*NEA Workshop on Utilization and Reliability of High Power Accelerators,*  
*13-15 October 1998, Mito, Japan*

Geneva, Switzerland  
October 1998

# THE LEP SUPERCONDUCTING RF SYSTEM: CHARACTERISTICS AND OPERATIONAL EXPERIENCE

D. Boussard and E. Chiaveri  
CERN, Geneva, Switzerland

## Abstract

The Large Electron Positron Collider (LEP), the largest accelerator in the world, is equipped with a superconducting RF system designed at CERN and constructed by European industry. The energy radiated by the circulating beams via synchrotron radiation is replenished by the RF system, which provides a total accelerating voltage of about 3 GV. Very large continuous RF power is thus transferred to the beam; in routine operation it amounts to more than 13 MW at a total beam current of 6 mA. The cryogenic installation, one of the largest in the accelerator world, delivers 48 kW at 4.5 K to keep the cavities superconducting. This paper describes the overall RF system, putting emphasis on the design choices and on the problems encountered during their implementation. It also reports on the operational experience with this system, showing that its reliability and performance has enabled LEP to largely exceed the goals set a few years ago.

## 1. Introduction

LEP, the largest particle accelerator in the world, is an electron-positron storage ring with a circumference of 26.7 km. Physics of  $Z_0$  particles started in 1989 at a collision energy of 45 GeV with a room-temperature RF system capable of delivering up to 340 MV at 352 MHz. The subsequent so-called LEP2 project consisted in increasing the collision energy to about the W pair particle production threshold by the adding of superconducting (SC) cavities developed at CERN since 1979.

The basic choices for the LEP SC cavities were made early in the project: 352 MHz (for compatibility reasons and to minimize the critical transverse impedance), four-cell structure with couplers on the beam tube, 4.5 K operating temperature, modular cryostat with easy access to the cavities and ancillary equipment, and thermal and magnetostrictive tuners inside the cryostat (Fig. 1) [1].

After an intense period of research and development CERN decided to replace the niobium (Nb) sheet metal, of which the cavities were made, with copper covered with a thin ( $\sim 1.2 \mu\text{m}$ ) niobium film (Nb/Cu cavities). This approach offers inherent advantages: considerably higher stability against quenching, insensitivity to small magnetic fields and a higher quality factor than that of solid Nb at a given frequency and working temperature (4.2 - 4.5 K). It is obvious that an important saving was achieved by replacing bulk Nb with an Nb layer.

CERN decided in 1990 to transfer the Nb/Cu technology to industry. It awarded the contract for manufacturing the cavities and modules (four cavities assembled together) to three European companies [2]. The entire series production was finished at the end of 1997 and at present 256 Nb/Cu

cavities plus 16 solid Nb cavities are installed in the LEP tunnel, providing about 3 GeV total accelerating voltage (Fig. 2).

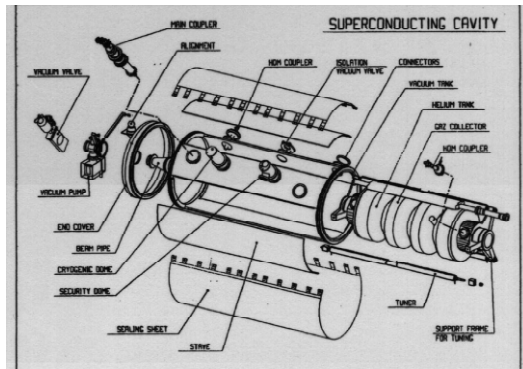

Fig. 1: Exploded view of one RF unit

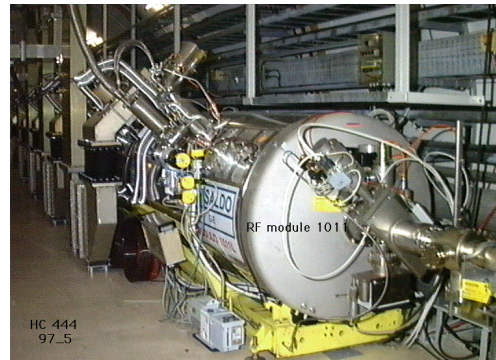

Fig. 2: RF module in the LEP tunnel

## 2. The SC cavity

The four-cell cavity is fabricated from OFHC (oxygen-free) copper, using spinning and electron beam welding techniques. Proper preparation of the copper surfaces (electropolishing, chemical treatment, high purity water rinsing) before welding and before thin film deposition is of the utmost importance. Sputtering the niobium layer is achieved with a magnetron discharge between a high purity niobium cathode and the cavity walls. A high degree of cleanliness (e.g. mounting of the magnetron cathode in a class 100 clean room) is necessary to achieve the required performance of the niobium layer.

The total superconducting surface produced for the LEP2 project amounts to more than 1500 m<sup>2</sup>; it must be free of dust particles, since these become electron emitters at high RF fields. Again the importance of clean room work for the final assembly of cavities, couplers and bellows to avoid field emission cannot be overemphasized.

The cavity proper is surrounded by its helium tank and its three tuner bars (see Chapter 4) and is suspended inside the cryostat (see Fig. 1). The latter, with its three wide barrel staves, provides easy access to the cavity as neither a magnetic shield nor an intermediate thermal shield is necessary. Thermal insulation is achieved with superinsulation mattresses alone. Four cavities are assembled together in a common cryostat to form a cryomodule 12.5 m long, including the end elements [3].

Table 1 shows the major parameters of the LEP2 cavities, the most critical being the quality factor  $Q_0$  at the operating field (6 MV/m). This is the parameter which is measured during the acceptance tests made at CERN for all cavities and modules produced by industry.

Frequency	352.209 MHz
Operating field	6MV/m
Operating voltage	10.2 MV
Number of cells	4
Effective length (four cells)	1.702 m
Modular length (between cryostat flanges)	2.553 m
Diameter: equator	755 mm
iris	241 mm
Relative pass band $2(f_p-f_0)/(f_p+f_0)$	1.76%
$E_{pk}/E_{acc}$	2.3
$B_{pk}/E_{acc}$	3.9mT/(MV/m)
R/Q ( $R=V^2/2P$ )	232
Field flatness tolerance $dE/⟨E⟩$	±5%
Tuning sensitivity	+40 kHz/mm
He pressure sensitivity	<10 Hz/mbar
Tuning range: slow	50 kHz
fast	1.6 kHz
$Q_0$ at operating field (4.5K)	>3.2 x 10 <sup>9</sup>
$Q_0$ at low field (4.5K)	>6.4 x 10 <sup>9</sup>
RF losses at 6 MV/m and 4.5K/cavity	<70W
Cryogenic standby losses per complete module	<90W
$Q_{ext}$ of RF coupler (nominal)	2 x 10 <sup>6</sup>
Loss factor for a complete module (four cavities and two end tapers) at $\sigma_z = 10$ mm:	
longitudinal	5V/pC
transverse	8V/pC.m

Table 1: LEP2 cavity parameters

### 3. RF couplers

#### 3.1 RF power coupler

The power couplers of the LEP2 cavities [4] are located on the enlarged beam tubes to avoid ports on the cavity cells themselves. The open end of the inner conductor of a coaxial line protrudes slightly inside the beam tube, close to the end cell. At the other end of the coaxial line a cylindrical RF window derived from those used in the LEP copper RF system is part of a waveguide-to-coaxial transition (Fig. 3). While the inner conductor of the line is at ambient temperature (air-cooled) along its whole length, the outer one is subject to the full temperature gradient from cavity to outside. It is made of a thin-walled stainless steel tube, copper-plated by sputtering. To avoid any welds in this critical area, this tube and its end flanges are machined out of a single forging. Helium gas cooling channels are provided on the outside of the tube.

The major problem found with this type of coupler is multipacting (resonant electron loading) in the coaxial line. To completely suppress any multipacting in the coaxial line during operation of the couplers, a d.c. bias voltage of + 2.5 kV is applied to the inner conductor [4]. In this way no resonant electron discharge can occur; this is obvious when the d.c. voltage is larger than the peak RF voltage in the line, but it can also be confirmed by simulations for lower d.c. voltages. No d.c. current is drawn by the coupler and a simple high-voltage d.c. supply feeds eight cavities in parallel. For the LEP2 project, the nominal RF power per SC cavity at full beam current (under matched conditions) is 120 KW at 352 MHz. On the experimental test set-up, using a single-cell superconducting cavity equipped with two RF couplers, RF power of more than 500 KW CW was transferred from the input

to the output coupler via the cavity [4]. In pulsed mode, up to 700 kW were achieved, showing that the couplers are overdimensioned for LEP2 use.

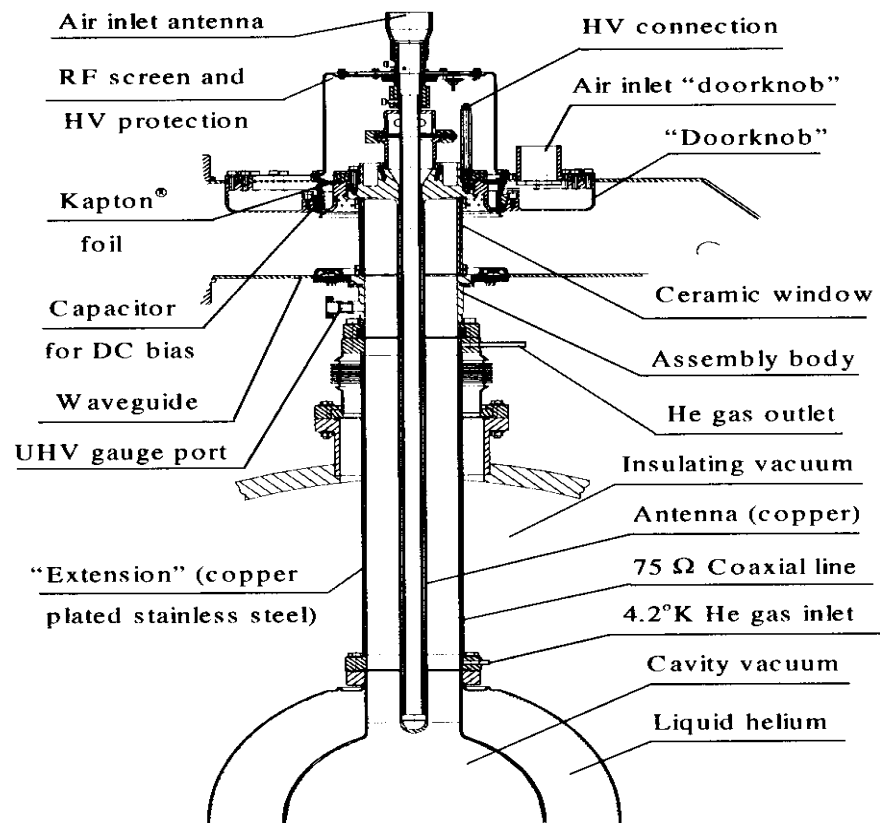

Fig. 3: Layout of the 75  $\Omega$  fixed coupler for LEP2

### 3.2 Higher-Order Mode (HOM) couplers

The circulating beam deposits electromagnetic energy in each cavity in the form of higher-order modes (HOMs). Since for SC cavities the natural attenuation is extremely small, this energy has to be removed by special means. In the LEP2 SC cavities this is achieved by using HOM couplers [3] to take the extracted energy outside the cryostat, where it is dissipated in room-temperature loads. The effectiveness of HOM couplers is most critical with the short bunches of LEP (r.m.s half length 8-10 mm).

An additional function of the HOM couplers is to reduce the impedance seen by the beam at each HOM frequency in order to minimize the risk of coupled bunch instabilities and to reduce the power deposited by the beam (avoiding resonant build-up). Each LEP2 cavity is equipped with two higher order-mode couplers. They are of the "hook" type in which a series notch filter at the RF frequency is established with the inductance of the "hook" and its capacitance to the wall of the cavity port. The connecting RF line between the cold coupler and the cryostat wall is a 25 cm "rigid" coaxial line made of two thin stainless steel copper-plated tubes. Finger contacts at either end of the line allow some mechanical displacements during cool-down. It was demonstrated experimentally that more

than 850 W can be transmitted through the HOM coupler and its line at 630 MHz (frequency of the dominant longitudinal HOM of the LEP2 cavity). Above 2.2 GHz (cut-off frequency of the 10 cm diameter beam tube) HOM power may propagate outside the SC cavity module.

#### 4. The Tuning system

The cavities are made from sheet metal and have, after electron-beam welding, frequency deviations up to 200 KHz and unequal field distributions. They are corrected during the fabrication process by unelastic deformation. Individual cells are adjusted in length to obtain a flat field distribution ( $\pm 5\%$  deviation in field) and the observed frequency variations (200 kHz) correspond to a change of a 5 mm in the total length of the cavity.

The very narrow cavity bandwidth ( $\pm 90$  Hz at  $Q_{\text{ext}} = 2 \times 10^6$ ) requires a very precise tuning system; this is based on the combined magnetostrictive and thermal effects of nickel tubes attached to the cavity. Three very rigid arms with 120° spacing are welded to the end flanges of the cavity and to the ends of the He tank. They are connected by three longitudinal, 2 m long nickel tubes forming a very rigid cage around the cavity. The total range of the fast tuner (magnetostrictive effect) varies from unit to unit between 1.6 and 2 kHz; a typical rise time is 50 ms for a step current change.

The coarse slow tuner is based on the controlled thermal expansion of the nickel tubes, which are cooled by a fixed flow of helium gas and heated in a controlled way at their centres. The slow tuning range is about 50 kHz and the speed greater than 8 Hz/s.

#### 5. The RF power system

The LEP RF system is based on high-power klystrons (1.3 MW), each feeding eight SC cavities via a circulator and a series of symmetrical magic tee splitting stages [7]. The circulator is terminated on its third port by a 300 KW load (Fig. 4). Each RF unit, comprising two klystrons fed by a common high voltage (HV), is totally self-contained and can be operated independently of the rest of the system. Since each klystron supplies eight cavities, the RF controls for the two groups of eight cavities were designed to be independent from each other. Therefore eight cavities are controlled by a single RF interlock trip. High-voltage interlocks are provided, which however can still switch off the whole unit of 16 cavities.

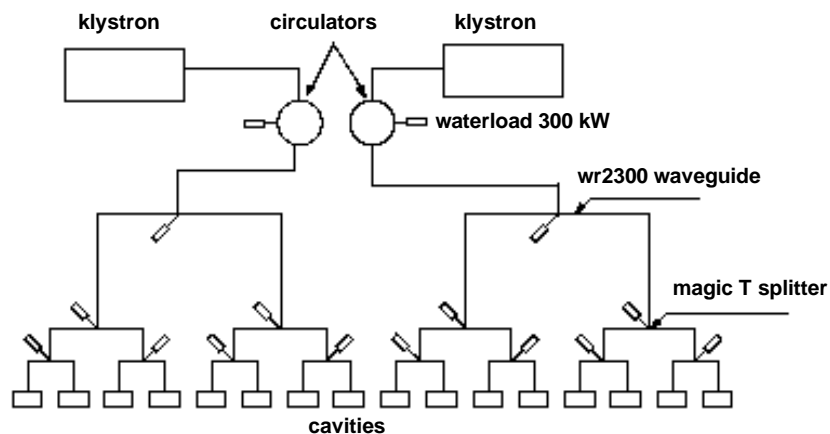

Fig.4: Layout of twin RF units sharing one common klystron supply

Regulation circuits for each klystron include a fast phase loop to suppress spurious phase modulation (essentially due to HV supply 600 Hz ripple) at the klystron output and a slow amplitude control acting on the modulator anode of the tube. The latter is used to control the sum of all eight

cavity voltages. To avoid beam instabilities and to control to some extent microphonic effects in the cavities, an additional fast (few kHz) RF loop is also available. It regulates the vector sum of the eight cavity signals (vector sum feedback loop).

The total voltage available for acceleration in LEP is regulated by a software controller (Global Voltage Control), which adjusts the power in each klystron to achieve the desired total voltage taking into account unavailable klystrons and/or cavities.

## **6. The cryogenic system**

The cryogenic system at each of the four acceleration points of LEP consists of a cryoplant with an equivalent cooling capacity of 12 KW (at present updated to 15 KW) at 4.5 K and its associated liquid helium (LHe) distribution system to supply the superconducting four-cavity module [3]. The He compression group, purifiers, low-pressure balloons and the He gas storage vessels and infrastructure equipment are installed in surface buildings and outside at each interaction point.

To fit into the available underground space, the cold box equipment is divided in two parts linked by a transfer line at about 20 K. A large cold box is situated at ground level and a smaller one in the machine access shaft, at the tunnel level.

The cold boxes are interconnected by transfer lines through the access shaft at between 50 and 140 m depths. From the smaller cold box the modules are cooled on each side through pairs of about 250 m long separate transfer lines, one for the LHe supply and one for the cold gas return. The cavities are cooled by a bath of boiling liquid helium (LHe) kept at 1.250 bar (absolute) at 4.45 K. A small percentage of the evaporated He is used for intercepting heat conducted along the RF couplers, tuners and beam tube transition cones.

## **7. Performance and reliability**

### **7.1 Cavities**

Like in any RF system, the SC cavities must be reconditioned after a long interruption. This is the case in particular at the end of the annual long machine shutdown. One or two weeks are dedicated to cavity conditioning at the start of a new run.

Cavity conditioning can be a simple RF processing, i.e. gradual increase of the RF field, limited by the vacuum level in the cavity and RF coupler. To reach the highest fields it is often necessary to use pulse processing (few ms long RF pulses at 100 ms intervals). A good indication of the quality of the cavity is the level of radiation produced by the spurious electrons (from the emitters, dust particles) accelerated all along a module. Typical levels range from a few krad/h to 50 krad/h. In the most difficult cases, even in the LEP tunnel, helium processing is used. With all these techniques the available accelerating field in LEP is significantly above its design value of 6 MV/m. In the coming years (1999-2000) it is foreseen that the cavities will be run up to an average field of 6.7 MV/m to reach an energy of 100 GeV.

Cryogenic measurements of the cavity quality factor  $Q_0$  (the only measurements of  $Q_0$  available when the cavities are installed) do not show any sign of degradation of the quality of the niobium



layer. There was only one incident which required removal of a module out of the tunnel. This module was accidentally exposed to a fast flow of clean nitrogen, following a human error in controlling the vacuum valves. Normally the cavities are vented to atmospheric pressure with a very slow flow of nitrogen to avoid transport of dust particles. The module was removed from the beam line (two-day operation) and completely disassembled. Each cavity was rinsed separately with ultrapure water and subsequently RF tested ( $Q_0$  vs E curve) to check again its performance. The module was then reassembled and reinstalled in LEP (the total duration of this repair was about one month).

## **7.2 Couplers**

The RF couplers were all conditioned on a warm test stand, in the travelling wave mode, at up to 200 kW prior to their installation on the s.c. modules. This guarantees a high safety margin during operation, and in fact, no serious incident with the RF couplers ever occurred. During cavity conditioning, the d.c. bias on the inner conductor is switched off to let multipacting discharges clean the coupler surface. Progress of conditioning is monitored by a vacuum gauge in the coupler, gauge which is also part of the RF interlock system.

For the HOM couplers, made of solid niobium, there is a risk of quench, in particular if spurious accelerated electrons impinge on the hook surface. Temperature sensors at the base of the hook would detect a quench and trigger the interlock system. At the present intensities (6 mA) and bunch lengths ( $\sigma_s > 8$  mm), the vast majority of HOM couplers shows no sign of temperature increase. However a few of them (five to six) exhibit a slow temperature rise which is at the moment still under investigation.

Another effect of the higher order modes excited by the beam in the cavity manifested itself recently. The small antennas used to monitor the RF field in the cavity also pick up the HOM fields at very high frequencies (~1 to 7 GHz). A substantial fraction of the power is dissipated in well-insulated cables inside the cryostat. As a result, a number of cables were burned. A campaign to replace these cables by thicker ones during the next shutdown is in preparation. Thanks to the cryostat design having a good accessibility this operation can be done in the tunnel without moving the modules.

## **7.3 Tuning system**

The SC cavities have a very small bandwidth ( $\pm 90$  Hz) and are therefore sensitive to microphonic effects. A mechanical excitation was found in the turbulent flow of helium in the input manifold of the cryostat and was rapidly corrected. Ponderomotive instabilities are observed with beam, when the cavity becomes detuned to compensate the reactive part of beam loading. They manifest themselves as strong oscillations (up to 50% of the cavity voltage) at the main mechanical cavity resonance (around 100 Hz). These instabilities, which may be incoherent from cavity to cavity, cannot be suppressed by the RF system, because a single klystron drives eight cavities. They are avoided by changing the tuner set points in such a way as to bring the cavities back to resonance, even in the presence of beam loading. Optimum set point values for each cavity are determined by software for a given beam current and energy.

Two other different methods have been recently tested to avoid ponderomotive instabilities: a small bandwidth feedback loop, working in parallel to the normal slow tuning loop, can effectively damp the cavity mechanical resonances around 100 Hz and raise the instability threshold. One can also reduce the effective sensitivity of the cavity to Lorentz force detuning (the primary source of ponderomotive instabilities) by using a feedforward link from cavity voltage to magnetostrictive tuner. Both methods have been successfully tested.

### ***7.4RF Power system***

The 34 klystrons driving the SC modules have so far accumulated between 2000 and 10000 operating hours, with an average of about 4000 hours. The average life-time of these high power klystrons is expected to be 18000 hours; in the LEP copper RF system one tube reached more than 28000 hours. Eight klystrons have been replaced since the beginning of LEP in 1989. To replace one klystron takes about half a working day.

In an SC cavity system a high-power reflected pulse (four times the incident power) is generated at each abrupt RF switch-off. These pulses caused damage in the 50  $\Omega$  coaxial to waveguide transitions which are installed between the circulators and their loads. In some cases the circulator itself had also been damaged. This problem has now disappeared with new 10  $\Omega$  transitions replacing the old ones.

Arcing in the waveguide system has been sometimes observed, possibly due to higher order modes excited by the beam itself. Arc detectors are installed in the waveguides; they are part of the global interlock system.

The electrical length of the waveguides, between circulator and SC cavities, must be adjusted accurately (less than a few degrees of RF phase), since otherwise beam loading leads to a large imbalance in cavity voltages during operation. In extreme cases (e.g. at injection) where a cavity voltage gets so low that the tuner no longer works, the entire RF unit will trip off. At high energy some cavity voltages will exceed their limits, leading again to RF trips if the electrical lengths of waveguides are not properly adjusted. A tedious programme of adjustments is under way to minimize these effects.

### ***7.5Cryogenic system***

The cryogenic system in itself is very reliable. During the years 1996 and 1997 the beam time lost due to the cryogenic system was less than 1% of the total (~ 4000) running hours.

Three interruptions of cooling helium supply occurred in 1996: one was due to a turbine stop (two hours lost for RF operation), while the other two were of outside origin: stop of cooling water and general power failure affecting all LEP installations. Table 2 summarizes the failures and associated down time during physics in 1997 [5].

Failure type	Place	RF down time
Emergency stop	IP4	16 h
Power cut	SPS	3 h
Instrumentation	IP8	6 h
Motor bearing	SPS	5 days

Table 2: LEP2 cryogenic failure statistics during physics in 1997

As illustrated by the preceding table, and also from general experience, the most troublesome incidents with the cryogenic system are due to outside sources, i.e. to either power or cooling water interruptions. The time needed to recover from a failure is practically proportional to its duration, according to the empirical formula [6]:

$$\text{Time to recover} = 3 \text{ hours} + 7 \times \text{failure duration.}$$

### 7.6 Overall reliability

The LEP2 RF system is a highly complex piece of equipment distributed over four geographical zones separated by long distances. Access to the equipment is not easy, all electronic control chassis being installed in remote underground areas. There are about 500 19" racks of electronic equipment to control the entire RF system, and over 9000 interlocks which can trip an RF unit or its high voltage power supply. It is therefore not surprising that a variety of problems are recorded, due to equipment failure, software bugs, or sometimes of unknown origin [7].

At the beginning of LEP2 exploitation, the average time between RF trips was 1h1/2; at present it is doubled (3 h), which indicates a significant improvement of the reliability of the overall system.

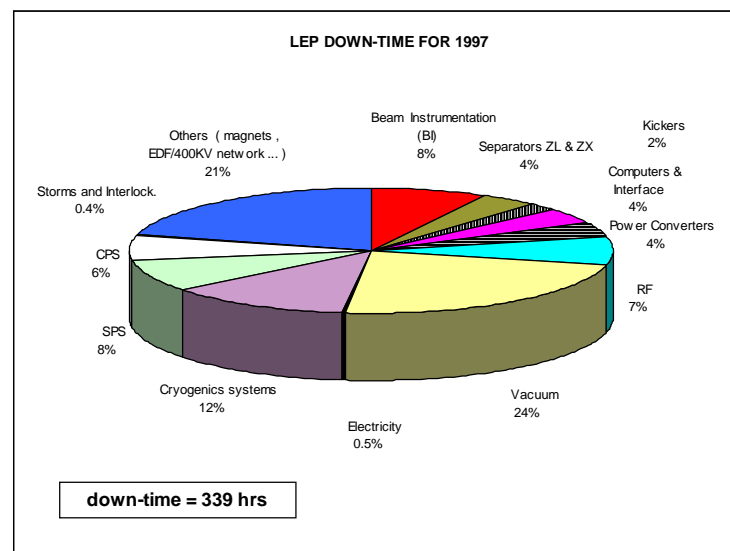

Fig.5: LEP down-time for 1997

Moreover, not all RF trips lead to beam loss. LEP can operate with up to two klystrons being switched off. In most cases after a trip the Global Voltage Control can restore satisfactory operating conditions in a short time (mainly limited by the speed of data transmission).

Fig. 5 gives an idea of the overall reliability of the RF system, as seen by its user, namely the operations group in charge of the running of LEP. In 1997, the total number of hours lost was 339, over the total running time of LEP (4000 hours). Only 7% of the 339 hours LEP down time can be attributed to the RF system. Those lost hours were mainly due to problems requiring major interventions on the waveguide system (klystron, circulator or water load to be replaced), or urgent accesses in the machine tunnel.

The 12% down-time attributed to the cryogenic system is for a large part not related to the cryoplants dedicated to the RF system, but to the cryogenics needed by the particle detectors installed in the four collision points of LEP. As mentioned already, most of the cryogenic down-time quoted here can be attributed to power or cooling water failures.

## **8. Conclusion**

The large scale application of SC RF technology in LEP has demonstrated the robustness of superconducting cavities and their couplers in an industrial-like environment. The same conclusion can certainly be drawn for SC cavities of future proton machines for which in fact some of the LEP problems would not even exist (e.g. those related to higher-order modes and to some extent those related to ponderomotive instabilities).

The overall LEP RF system is still in a stage of improvement, following our experience gained with beam during the last two or three years, and its reliability will certainly continue to improve. It must be emphasized that LEP, and in particular its RF system, is at the same time an industrial plant of large size and a prototype equipment, in continuous evolution and always pushed to its limits by the demands of high energy physicists. Despite these somewhat conflicting requirements the LEP RF system has already achieved a performance and a reliability record which just a few years ago looked almost impossible to attain.

## **9. Acknowledgements**

It is a pleasure to acknowledge all the people who engineered, constructed and put into operation the LEP2 RF system. The success of this undertaking would not be possible without their ability, competence, dedication and long-lasting commitment.

We are grateful to O. Brunner and Ph. Gayet for very useful discussions.

We are indebted to Prof. V.L. Telegdi for his helpful advice and critical reading of this paper.

## 10. References

- [1] D. Boussard, Performance of the LEP2 SRF System, PAC'97, Vancouver, Canada, 12-16 May 1997
- [2] E. Chiaveri, Large Scale Industrial Production of Superconducting Cavities, 5th European Particle Accelerator Conference, Sitges, Spain, 10-14 June 1996
- [3] LEP Design Report, Vol. III, LEP2, CERN 1996, Editor: C. Wyss
- [4] H.P. Kindermann, M. Stirbet, RF Power Test of LEP2 Main Couplers on a Single Cell Superconducting Cavity, Eighth Workshop on RF Superconductivity, Abano Terme (PA), Italy, 6-10 Oct. 1997
- [5] Proceedings of the Eighth LEP Performance Workshop, Chamonix, January 27-30, 1998, p. 166
- [6] Ph. Gayet, Private Communication
- [7] J.P.H. Sladen, Status of Superconducting Cavities in LEP, Eighth Workshop on RF Superconductivity, Abano Terme (PA), Italy, 6-10 Oct. 1997