

NON-INTERCEPTING BUNCH LENGTH MONITOR FOR PICOSECOND ELECTRON BUNCHES

H. H. Braun, C. Martínez, CERN, Geneva, Switzerland

Abstract

A bunch length monitor for very short electron bunches, r.m.s. ≤ 1 ps, has been implemented in the CLIC (Compact Linear Collider) Test Facility (CTF) at CERN. It consists of a long, rectangular waveguide connected at one end to the beam pipe and a detection system at the other end. Information on the bunch length is obtained by frequency-domain analysis of the signal excited by the beam in the waveguide. The signal can be detected either by a fast diode detector or by a RF mixer in combination with a RF sweep oscillator. With the diode detector, single-shot measurements can be performed, while the mixer set-up allows quantitative bunch length measurements for single bunches and for bunch-trains. The design and installation of two monitors and detection systems operating in two different frequency bands, K_a (26.5–40 GHz) and E (60–90 GHz), are described. Results obtained with the new monitor are presented and compared with bunch length measurements that were performed simultaneously with a streak camera recording Čerenkov radiation.

1 INTRODUCTION

The feasibility of accelerating an electron beam with 30 GHz RF power produced by a second beam (drive beam) according to the CLIC scheme [1] is being studied at the CTF. In order to have a good efficiency for the power obtained from the drive beam, the r.m.s. length of the electron bunches has to be 2 ps or less.

The CTF drive linac is able to produce a single bunch beam with a charge up to 50 nC or a train of 48 bunches with a total charge of 600 nC at an energy of 50 MeV. A bunch compressor is used to reduce the bunch length down to 0.5 ps (r.m.s.). It consists of a magnetic chicane (three dipole magnets); a very flexible system that allows different compression factors by varying the field strength of the dipoles [2].

So far, bunch length has been measured with a streak camera using transition or Čerenkov radiation. This is an invasive technique which, in this case, has an overall resolution not better than 2 ps (r.m.s.). In order to obtain a more accurate measurement a novel, non-intercepting bunch length monitor has been developed and tested in the CTF drive linac [3].

The new monitor measures the spectrum of the electromagnetic field of the bunch collected by a rectangular RF pick-up connected to a waveguide of the same dimensions. Figure 1 shows a layout of the beam-waveguide coupling. The waveguide transports the signal to the detection system.

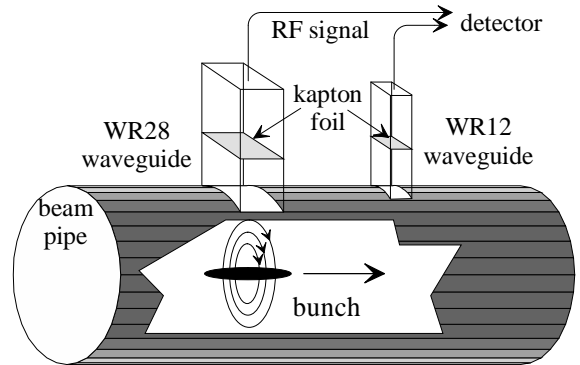

Figure 1: Layout of the coupling between the beam pipe and the waveguide.

The field induced in the waveguide has a temporal evolution directly related to that of the electron bunch. Hence, it is possible to derive the spatial charge distribution from the frequency spectrum of the field excited in the waveguide [4, 5].

The coupling of the field radiated by the bunch into the waveguide is calculated with the code MAFIA. The waveguide imposes a low-frequency cut-off to the spectrum of the propagating field and the transmission through the waveguide is affected by dispersion and attenuation.

2 EXPERIMENTAL SET-UP

Two pick-ups have been installed in the CTF drive linac (Fig. 2), one for a WR28 waveguide and the other one for a WR12 waveguide. The pick-ups are installed in a drift section of the drive linac, 180 cm after the bunch compressor and with a 13 cm space between the two pick-ups. A KaptonTM foil is used to isolate the vacuum in the beam pipe from the atmospheric pressure in the waveguides.

The WR28 waveguide has a low-frequency cut-off at 21.1 GHz and is suitable to cover the frequency range 26.5–40 GHz. The frequency range covered by the WR12 is 60–90 GHz and the cut-off is at 48.4 GHz. In these frequency ranges only the TE_{10} mode can transport the signal; the next mode starting at 42 GHz for the WR28 and at 94 GHz for the WR12 waveguide.

The waveguides transport the signal to the detection system, situated in a different room to avoid radiation damage. The WR28 waveguide has an attenuation of ≈ 0.1 dB/m and the total length is about 16 m. For the WR12 waveguide the attenuation is larger (≈ 0.2 dB/m) and the quantity of power coupled is smaller than that of the other waveguide, therefore the waveguide has the minimum length required to reach the detection system (10 m).

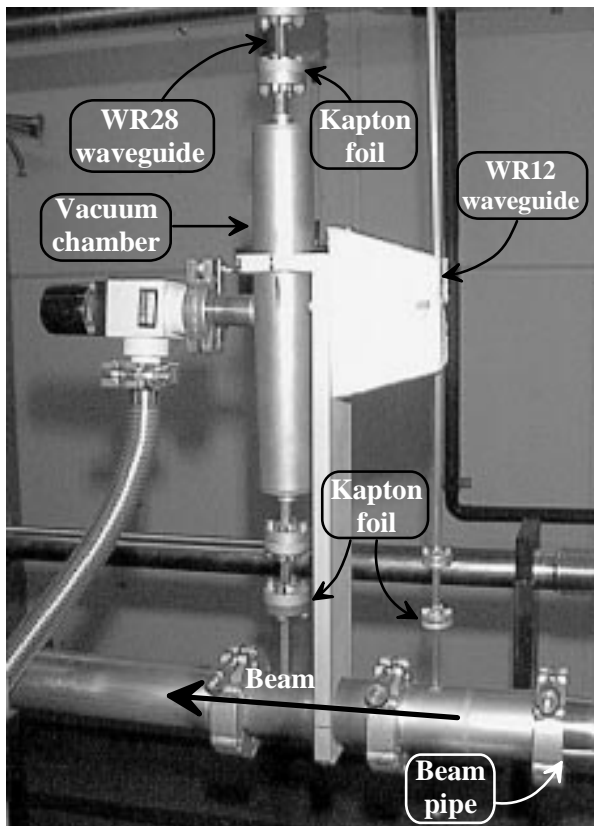

Figure 2: Beam pipe-waveguide coupling as installed in the CTF drive linac.

3 DETECTION SYSTEM

An absolute calibration of the detection system was tried by using the results obtained with MAFIA for the energy coupled in the TE_{10} mode and taking into account the dispersion and attenuation in the waveguides. This method has been unsuccessful; the main reason being that several components of the system could not be properly calibrated due to a lack of appropriate calibrating equipment in the required frequency range.

Detection is either by a fast diode detector or by a RF mixer in combination with a RF sweep oscillator. A diode detector allows single shot measurements and has proven to be a very fast qualitative method to obtain the bunch compressor set-up that minimises the bunch length. Disadvantages of this method are the difficulty of measuring bunch trains, due to interference effects, and the calibration process, as an independent bunch length measurement (e.g., the streak camera) is required to calibrate the system.

Although the mixing technique requires a more complicated set-up, it has many advantages. It is possible to calibrate by means of a self-consistent calibration procedure (without the use of a second method for cross-checking), gives a high frequency resolution and, moreover, it is able to measure the frequency spectrum of a train of bunches.

Figure 3 shows the set-up for both lines. The first mixer (with a fixed frequency local oscillator) down-shifts the fre-

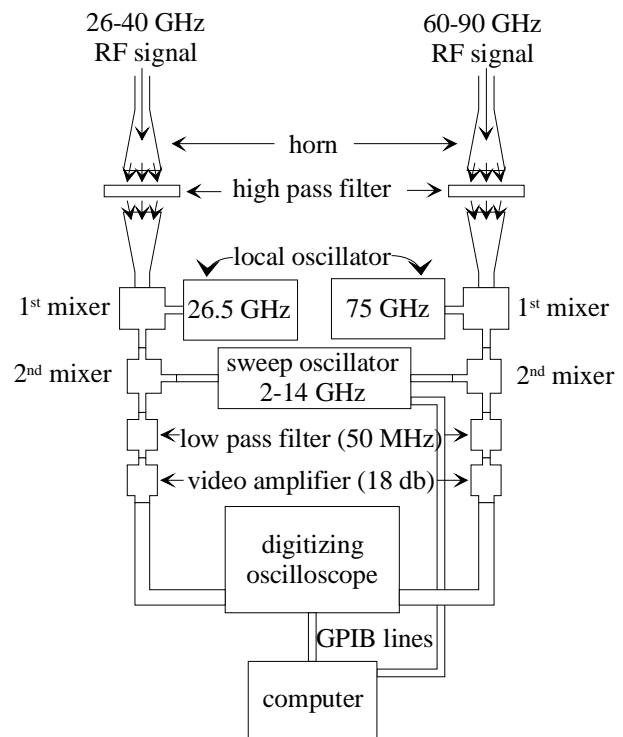

Figure 3: Detection system.

quency spectrum of the incoming RF signal, by 26.5 GHz in the case of the WR28 line and by 75 GHz in the case of the WR12. A high-pass filter is used to prevent the part of the spectrum below the oscillator frequency adding to the signal. As the second oscillator sweeps between 2 and 14 GHz, the RF signal is down-shifted a second time so that it can be detected by the oscilloscope. A low-pass filter is used to reduce the bandwidth of the signal detected by the oscilloscope (increasing the frequency resolution) and a video amplifier is used to get signal levels suitable for the oscilloscope.

With this procedure, it is possible to obtain the frequency spectra of the RF field in the ranges 28.5–42.5 GHz and 77–91 GHz. It is possible to extend the range of the measured spectrum by using the high-pass filter (a grid with cylindrical holes [6]) as a reflector; in this case it behaves like a low-pass filter and it is possible to scan the range 61–73 GHz. The whole system is driven by a PC using a GPIB.

Scanning the frequency spectrum in the whole frequency range available turned out to be too long a procedure for bunch compressor optimisation; therefore, it was decided to measure the signal only at several frequencies points (30, 39, 63, 72, 78 and 87 GHz). The data obtained are then fitted to a parabolic function by minimising the χ^2 . It can be proven that the development to second order of a symmetric form factor (Gaussian, triangular...) depends only on the r.m.s. value of the bunch length; this justifies the use, for not too high frequencies, of a parabolic function to fit the data. The fitting parameters are the r.m.s. bunch lengths and

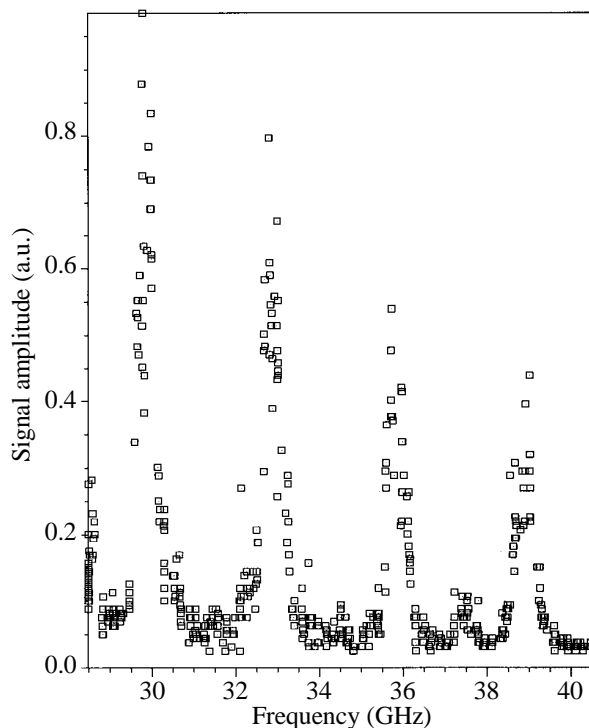

Figure 4: Measured frequency spectrum for a train of 8 bunches.

the different response factors for each frequency; thus taking into account the variation of the system response with frequency.

4 RESULTS

The frequency spectrum of a train of bunches is shown in Fig. 4 in a range covering 28.5–40.5 GHz. This result was obtained by using the mixing technique for a train of 8 bunches with a total charge of 13.4 nC. The bunches in the train were spaced by 0.33 ns which corresponds exactly to the 3 GHz distance between the lines of the spectrum.

Several measurements were performed with the mixing technique for different bunch compressor settings. At the same time, the bunch length was measured with the streak camera using Čerenkov radiation. Figure 5 shows a comparison between the measured r.m.s. bunch length and the predicted values from PARMELA simulations. Also shown are the results from the streak camera measurements. This set of measurements was obtained for a train of 24 bunches with a total charge of 34 nC. The bunch length decreases while increasing the current in the bunch compressor until a minimum value is reached and then the length starts to increase again. The values for the bunch length measured with the mixing technique are in excellent agreement with the theoretical values obtained with the code PARMELA for the different settings. The measurements for very short bunch lengths are dominated by the resolution of the monitor. It can be seen that the resolution of the streak camera is not better than 2 ps.

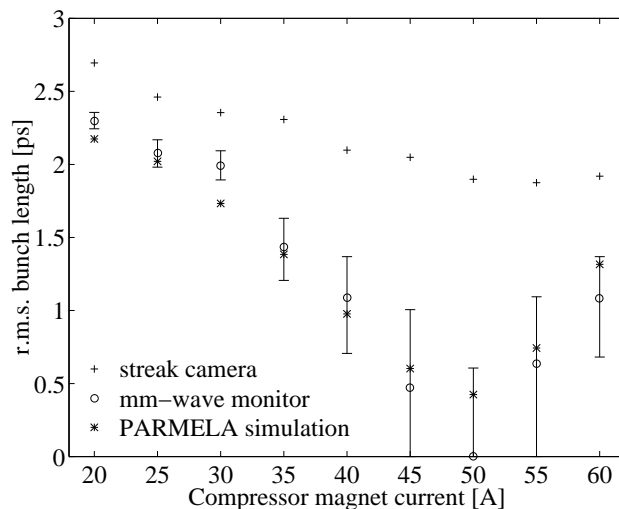

Figure 5: Bunch length measurements.

5 CONCLUSIONS

It has been demonstrated that the monitor developed is a suitable non-invasive tool for measuring very short bunches. It has been possible to measure the line spectrum and the bunch length for a train of bunches. The results correspond exactly to what is expected from theory.

Resolution is at the moment around 0.7 ps but it can be improved by extending the frequency range beyond 100 GHz.

In order to increase the speed of the measurement, the possibility of using a VME crate to control the whole process instead of a PC is under study.

6 REFERENCES

- [1] The CLIC study group, “CTF2 Design Report”, CERN-PS 96-14(LP) (CLIC Note 304), June 1996.
- [2] F. Chautard, “Un compresseur de Paquets d’Electrons Fortement Charges au CERN”, PhD thesis dissertation at Univ. Paris 6, May 1996.
- [3] C. Martinez, “Determination of the Longitudinal Distribution of Picosecond Electron Bunches”, PhD thesis in preparation (Univ. Politècnica de Catalunya - CERN).
- [4] J.C. Swartz and 6 co-authors, “Non-destructive Diagnostics for Relativistic Picosecond Bunched Electron Beams”, *Physical Review E*, Vol. 52, N. 5, November 1995.
- [5] E. Babenko and 3 co-authors, “Length Monitor for 1 mm SLC Bunches”, *SLAC-PUB-6202*, June 1993.
- [6] A. Roberts and 3 co-authors, “Thick Grids with Circular Apertures: a Comparison of Theoretical and Experimental Performance”, *International Journal of Infrared and Millimeter Waves*, Vol. 15, N. 3, pp. 504-517, 1994.