

APPLICATION OF SUPERCONDUCTING CAVITIES TO FACTORIES

KAZUNORI AKAI*

*High Energy Accelerator Research Organization (KEK),
1-1, Oho, Tsukuba, Ibaraki-ken, 305 Japan*

(Received in final form 15 January 1998)

Recently, the application of superconducting (SC) cavities to collider-type particle factories is becoming of great importance in the field of particle accelerators. The use of SC accelerating cavities in factories is attractive for a high accelerating voltage, a high stored energy and low impedance. There are two factory projects which have SC cavities under construction: the asymmetric energy B-factory at KEK (KEKB) and the luminosity upgrade of CESR to phase III. In addition, SC cavities will be used in two future projects: the Beijing τ -charm factory at IHEP (BTCF) and the large hadron collider at CERN (LHC). These factories are required to store a high beam current of several amperes with a short bunch length in order to achieve a very high luminosity in the range of $5 \times 10^{32} - 10^{34} \text{ cm}^{-2} \text{ s}^{-1}$. In applying SC cavities to factories, many challenging tasks have been set, most of which come from extremely heavy beam-loading. In particular, key issues are the heavy damping of HOMs, the stability of the accelerating mode and high power handling capability. Extensive efforts have been made to develop SC damped accelerating cavities to meet the heavy demands; successful results have been obtained at bench tests and beam tests with beam currents of more than 500 mA. Another attractive application of SC cavities to factories is a SC crab cavity. The R&D of SC crab cavities is in progress at KEK to prepare for the potential need of the crab-crossing scheme in KEKB.

Keywords: Superconductivity; Radiofrequency; Cavities; Factories

1 INTRODUCTION

A “factory” is a high-luminosity accelerator facility which provides a high-rate production of some particular particles for very precise experiments. All factories now being constructed or planned are

* E-mail: kazunori.akai@kek.jp.

electron-positron (e^+e^-) colliders to produce B mesons (B-factories), ϕ mesons (ϕ factories), and τ -leptons and J/Ψ particles (τ -charm factory). The design luminosity ranges from 5×10^{32} to $10^{34} \text{ cm}^{-2} \text{ s}^{-1}$, which reaches nearly two orders of magnitude higher than that of the already existing e^+e^- colliders.

Table I summarizes the factories, which have been commissioned, are under construction or are expected to be approved soon. KEKB¹ and PEP-II² are asymmetric-energy B-factories, which are under construction, and will be commissioned in 1998. The energy asymmetry is of vital importance to KEKB and PEP-II, which aim to detect the B-meson-related CP-violation effect. The luminosity upgrade of CESR to phase-III,³ though a symmetric energy collider, will increase its luminosity to a level comparable to that of the asymmetric B-factories. The Frascati ϕ factory, DAΦNE,⁴ started commissioning in 1997. Another ϕ factory is under construction at INP, Novosibirsk,⁵ although the financing plan has been drastically detained. As for τ -charm factories, among several plans that have been studied and proposed in a few laboratories, one project, Beijing TauCharm Factory at IHEP (BTCF)⁶ is alive: the institute of IHEP expects its R&D to be approved soon. The CERN high-luminosity

TABLE I Main parameters for the e^+e^- factories, together with the LHC

	KEKB	PEP-II	CESR-III	DAΦNE	INP- ϕ	BTCF	LHC
Physics	B	B	B	ϕ	ϕ	τ -charm	p-p col.
No. of rings	2	2	1	2	1	2	2
Energy symmetry	Asymm.	Asymm.	Symm.	Symm.	Symm.	Symm.	Symm.
Particle	e^+/e^-	e^+/e^-	e^+e^-	e^+/e^-	e^+e^-	e^+/e^-	p/p
Beam energy (GeV)	3.5/8.0	3.1/9.0	5.3	0.5	0.5	1.5–2.5	7.0 TeV
Luminosity (10^{33})	10	3	1	0.53	1	1	10
Current/beam (A)	2.6/1.1	2.14/1.0	0.5	1.4–5	0.27	0.57	0.53
Circumference (m)	3016	2199	768	97.7	35.2	385	26659
No. of bunches	5000	1658	45	30 (120)	1 (3)	86	2800
Revolution (kHz)	99.4	136.3	390	3069	8517	778	11.2
Bunch length (cm)	0.4	1.0/1.15	1.3	3.0		0.76	7.5
β_x^* (cm)	33	50/67	100	450	1	65	
β_y^* (cm)	1	1.5/2	1.3	4.5	1	1	
Cross. angle (mrad)	± 11	0	± 2.1	± 12.5	0	± 2.6	± 0.1
RF freq. (MHz)	508.887	476	500	368.25	700	476	400.8
RF voltage (MV)	9.4/16.2	5.1/14.0	12	0.26	1	6.8	16
Cavity type	NC/SC+NC	NC	SC	NC	SC	SC	SC
No. of cavities	20/8+12	6/20	4	1/1	1	3/3	8/8
First collision	1998	1998	1998–99	1997			

proton-proton collider (LHC)⁷ is also referred to in this paper, since its RF system is in some respects similar to the e^+e^- factory RF system.

As shown in Table I, the strategy to achieve their luminosity goals is common to many factory designs: (1) high beam current of several amperes with many bunches, (2) short bunch length and small β^* at the interaction point, and (3) a double-ring collider in most cases. In order to realize these conditions, many challenging tasks are placed on the RF system. Most of them result from the extremely heavy beam-loading. The challenging tasks include: heavy higher-order mode (HOM) damping schemes with HOM absorbers, cures for an instability driven by the accelerating mode, high-power input couplers, high-field performance, stable operation and low-level control issues.

The superconducting (SC) accelerating cavities will be used in KEKB, CESR-III, BTF and LHC, taking advantage of the high accelerating voltage, high stored energy and low impedance. In addition, SC crab cavities are being developed for KEKB to prepare for the potential need of the crab-crossing scheme. Besides the factories, there are other applications of SC cavities to high current machines, for example a synchrotron light source project in France (SOLEIL), although details are not given in this paper. The following discussion mainly focuses on these factories employing SC cavities.

2 SYSTEM LAYOUT

Figure 1 shows a schematic layout of KEKB. The two rings of HER for e^- and LER for e^+ of KEKB are being built in the existing tunnel where TRISTAN had been operated. The KEKB-HER RF system will be a hybrid one, where eight single-cell SC cavities will be used in parallel with twelve normal conducting (NC) cavities. The SC cavities will be installed in the Nikko straight section, where TRISTAN SC cavities had been operated and the existing 6 kW refrigerator is ready for KEKB. Four SC cavities will be installed for commissioning in 1998, and four other cavities are expected to be added later.

Figure 2 shows a layout of the CESR-III near the interaction region. For the CESR-III upgrade, which is expected to be completed between 1998 and 1999, all of the existing five-cell NC cavities will be replaced by four single-cell SC cavities. At present, as of

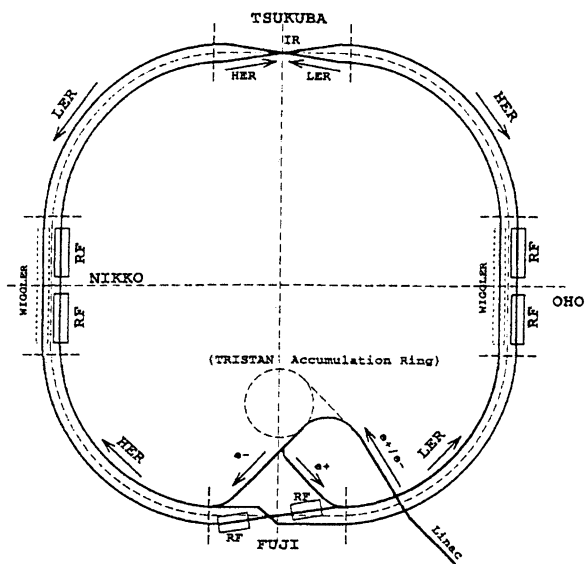

FIGURE 1 Schematic layout of KEKB.¹

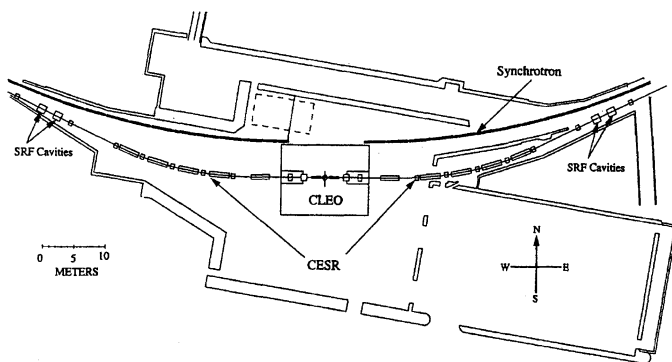
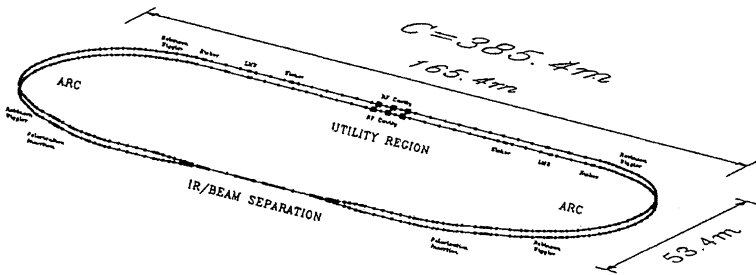
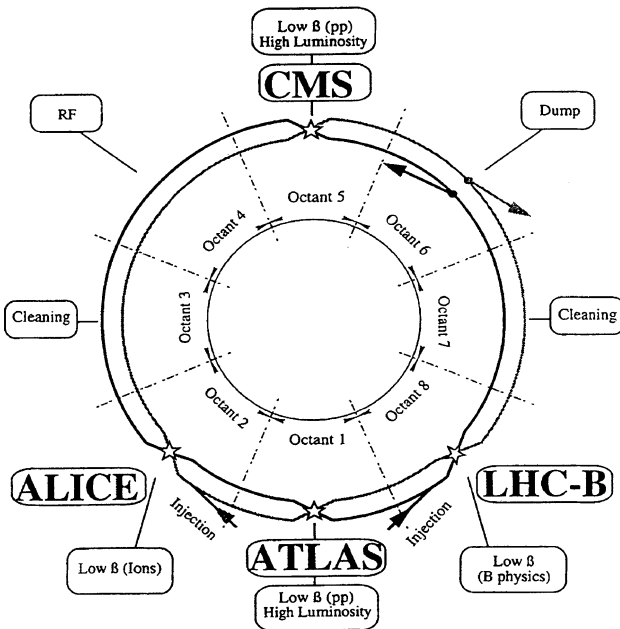

FIGURE 2 Schematic layout of CESR phase III near the interaction region.¹²

October 1997, the maximum beam current is limited by a multi-bunch instability caused by HOMs in the NC cavities.⁸ In October 1997, one SC cavity was installed, and has been operated for physics experiments.

FIGURE 3 Schematic layout of BTCF.⁶FIGURE 4 Schematic layout of LHC.⁷

BTCF (Figure 3) is planned to have three modes of operation: (1) high-luminosity mode, (2) longitudinal-polarization mode, and (3) monochromator mode. The parameters for the high luminosity mode are shown in Table I. The SC cavity is considered to be the first choice; a feasibility study has been completed based on the CESR-III and KEKB SC cavity designs. Three single-cell SC cavities are to be used.

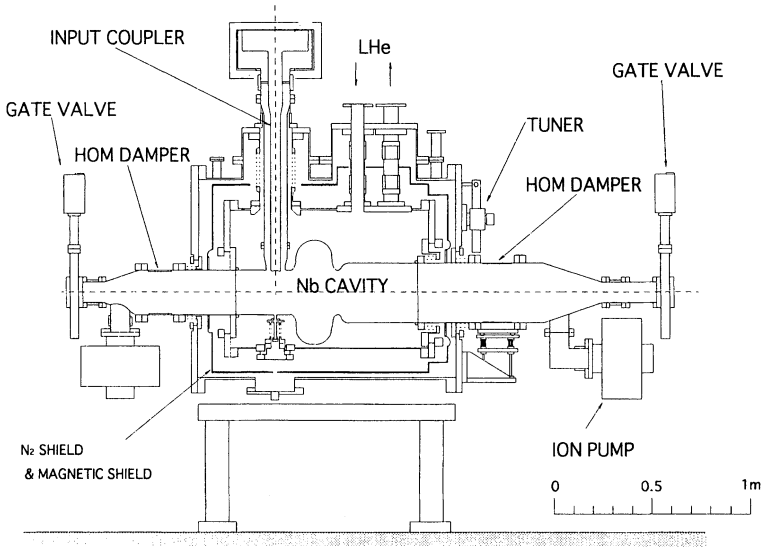

FIGURE 5 SC cavity-cryostat system for KEKB.¹⁰

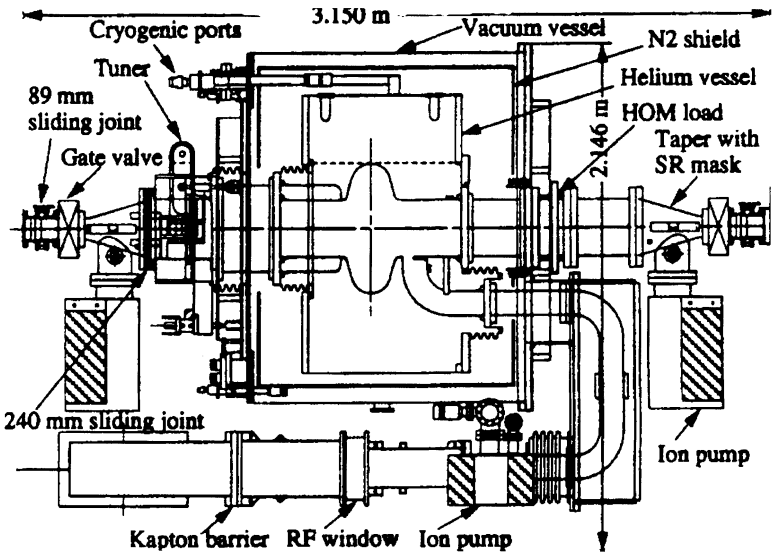

FIGURE 6 SC cavity-cryostat system for CESR-III.¹²

LHC (Figure 4) will be installed in the LEP tunnel after removing the LEP e^+e^- collider. It has four colliding points and two high-luminosity insertions. There will be a common cryostat for four single-cell cavities. Eight cavities in two cryostats will be used for each beam.

Figures 5 and 6 show schematic layouts of the KEKB SC^{9,10} and the CESR-III SC^{11,12} cavity modules, respectively. One cryostat contains one cavity in both cases. The resonant frequency is controlled by a tuner which changes the cavity length. The input coupler for KEKB is of the coaxial type with a ceramic disk window, that for CESR-III is wave-guide type with a planar ceramic window.

3 CHALLENGES OF SC CAVITIES FOR FACTORIES

3.1 HOM Damping Scheme

A very high beam current can cause strong coupled-bunch instabilities. The growth rate of any coupled-bunch instability must be smaller than the damping rate, or at least smaller than the level where the instability can be suppressed by a bunch-by-bunch feedback system or other methods. The HOM impedance must be sufficiently reduced to typically below 1 k Ω per cavity for any monopole modes, and a few k Ω /m for dipole modes. The Q -values should be reduced to typically below 100, which is much lower than those achieved with conventional damping schemes. In addition, it is also desired to have a low broadband impedance so that the loss factor is reduced.

The HOM-damping scheme adopted for the KEKB and CESR-III SC cavities is to use a single-cell cavity with widely opened beam pipes (Figures 5 and 6). This scheme allows for a simple structure, and is favorable for SC cavities. The single-cell is also beneficial to another requirement of large RF power to be transferred to the beam. The HOMs are extracted from the cavity via the beam pipes and absorbed by HOM dampers attached inside the beam pipes at room temperature. In order to damp the lowest-frequency dipole modes, one beam pipe is further enlarged for the KEKB cavity, or a fluted beam pipe¹³ is adopted for the CESR-III cavity. The damping properties for HOMs have been studied using computer codes, such as SUPERFISH, SEAFISH, MAFIA and HFSS, and by measurements.

The agreement between the calculation and measurement is usually good, and sufficient damping has been obtained.

In some cases, two or more single-cell cavities may be linked with wide beam pipes without tapers in-between. If the required damping is relatively modest, HOM couplers, instead of the absorbing material, can be mounted at the beam pipes and the cavities with the wide beam pipes can be housed in a common cryostat. This scheme has been adopted for the LHC and SOLEIL cavities.

In the case of NC cavities, the widely opened beam pipes reduce the impedance of the fundamental mode to an unacceptable level. The damping methods adopted for the NC cavities can be classified as follows: (1) by using wave-guides, the cut-off frequencies of which are above the fundamental mode, but below the lowest HOM, and (2) by using a coaxial or radial line with a notch filter which rejects the operating mode. The former method is used in many NC damped cavities, including PEP-II,¹⁴ KEKB NC¹⁵ and DAΦNE¹⁶ cavities. The latter scheme was originally independently proposed for linear colliders¹⁷ and for a crab cavity.¹⁸

3.2 HOM Damper

Although considerable efforts have been made to reduce the loss factor of the cavity and related beam-pipe components, the beam-induced power going to the HOM absorbers amounts to several kW per absorber, or even up to 10 kW in some cases, due to the very short bunch length and high beam current. This power corresponds to an average power density of about 10 W/cm² on the surface of the absorbers. In addition, the absorber is required to have the following properties: a wide band, low-reflection, low coupling impedance and working in a vacuum at a low outgas rate.

The HOM absorber for the KEKB cavity is made of IB-004 ferrite, product of TDK Inc. The ferrite is bonded to a beam pipe by the hot isostatic press HIP method.¹⁹ Before packing the ferrite powder between an inner can and an outer copper pipe, the powder is baked at about 300°C in dry nitrogen gas in order to reduce the outgas rate. The HOM absorber for the CESR-III cavity is made of TT2-111R ferrite tiles, product of Trans-Tech Inc. The ferrite tiles are soldered to 18 copper plates bolted along the inside of a stainless steel shell.²⁰

High-power tests of the dampers were done at KEK and Cornell, using a klystron and a coaxial line: an inner conductor was placed concentric to the HOM load. Two KEKB dampers, both small and large beam pipe ones, were tested up to 11.7 and 14.8 kW, respectively. The former corresponds to an average power density of 14.6 W/cm^2 . There was no damage on the ferrite.¹⁹ The CESR-III damper reached an average power density of 20 W/cm^2 .²⁰ Both tests were done in the air. As described later, the dampers have also been tested with a high-current beam in TRISTAN-Accumulation Ring (AR) and CESR. The results were very successful: the KEKB damper was tested in the AR up to a beam current of 570 mA, and absorbed up to 4.2 kW of the beam-induced power. No degradation of the performance of the HOM absorbers was found during the experiment. The CESR-III damper was tested up to 220 mA, and a beam-induced power of 2 kW was absorbed.

3.3 Instability Driven by the Accelerating Mode

In a large-circumference ring, the accelerating mode, itself, can cause strong longitudinal coupled-bunch instabilities with a coupled-bunch mode of -1 , -2 , and so on. In storage rings, the resonant frequency of the cavities should be detuned toward the lower side in order to compensate for the reactive component of the beam loading. Without this detuning, a large amount of RF power is reflected from the cavity, and extra power is required. The detuning frequency (Δf) for the optimum tuning is given by

$$\Delta f = \frac{I \sin \phi_s}{2V_c} \times \left(\frac{R}{Q} \right) f = \frac{P_b \tan \phi_s}{4\pi U},$$

where f is the RF frequency, I the beam current, ϕ_s the synchronous phase, V_c the cavity voltage, P_b the power to the beam, and U the stored energy in the cavity. If a high beam current is stored in a large storage ring, such as B-factories, Δf can be comparable to, or even exceed, the revolution frequency. The coupling impedance at the upper synchrotron sideband of the revolution harmonic frequencies becomes significantly high due to the high impedance of the accelerating mode. The growth time can be of the order of 10–100 μs , which is

much faster than the radiation-damping time. A key issue for the B-factory RF system is how to avoid this instability, whereas this is no problem for the ϕ and τ -charm factories, since they are relatively small rings and the revolution frequency is large.

The detuning frequency of SC cavities is smaller than that of conventional NC cavities, since the SC cavity has a lower R/Q value and can be operated at a higher accelerating voltage. The use of SC cavities is a straightforward solution to conquer this instability in KEKB-HER, where the growth rate becomes smaller than the radiation-damping rate. In KEKB-LER, however, the growth rate is still much higher than the radiation-damping rate, even with SC cavities.¹ Using SC cavities in KEKB-LER requires either further reducing the R/Q value to less than half or relying on fast feedbacks with a comb filter as PEP-II (see below).

There are two different ways with NC cavities to conquer this instability. One is to use the accelerator resonantly-coupled with an

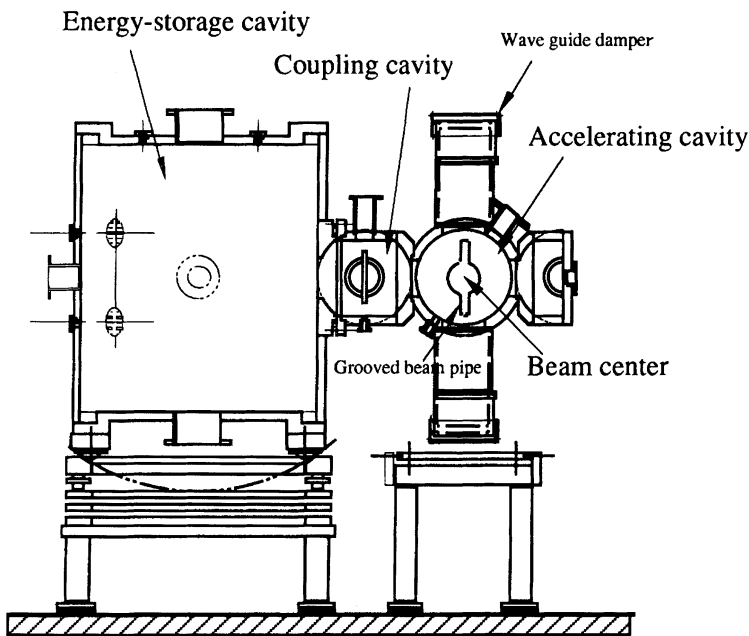

FIGURE 7 The ARES NC cavity.¹⁵

energy-storage (ARES) NC cavity system^{21,15} (Figure 7). The ARES is a three-cavity system where an accelerating cavity is resonantly coupled with an energy-storage cavity operating in a high- Q mode via a coupling cavity in between. This system increases the total stored energy by an order of magnitude, while the cavity dissipation power is kept at a reasonable level. The high stored energy reduces the detuning frequency. By using the ARES, the growth rate becomes smaller than the radiation-damping rate in KEKB-LER and -HER. The other way to avoid this instability, that the PEP-II proceeds, is by using a combination of feedback loops: a direct loop, a comb filter loop and a bunch-by-bunch feedback system.²² Test measurements and simulation work have shown that the driving impedance can be reduced from 760 to 10 k Ω .²³

3.4 High Power Handling

A large amount of RF power should be transferred to the high-current beam: of the order of MW for the B-factories and several hundred kW for the ϕ and τ -charm factories. On the other hand, the required RF voltage is typically 5–20 MV or less. The voltage, although relatively high compared to the radiation loss in order to provide a short bunch length, is much lower than that of colliders at the energy-frontiers. In addition, in view of reducing the total impedance in the ring, it is desired to have the smallest number of cavities as possible. As a result, each cavity should provide several hundred kW to the beam, which is much higher than that at the energy-frontier colliders. The RF power-handling capability of each cavity system should be improved to a large extent.

The most challenging part in this regard is RF input couplers. Intensive R&D is in progress, and recent test results encourage us. The input coupler for the KEKB SC cavities is a coaxial type, the same as that had been used for the TRISTAN SC cavities, but with a small modification. Two couplers, back-to-back assembled in a test bench and evacuated, have been tested up to an 850 kW CW throughput power and up to a 240 kW total reflection condition.²⁴ The input coupler for CESR-III is a planar wave-guide window of a single Al₂O₃ ceramic disk. The couplers have been tested up to 450 kW CW (limited by the available RF power) and 520 kW pulsed at 25% duty

cycle.²⁵ At CERN two LEP-type couplers were tested up to 500 kW CW travelling wave power.²⁶

The availability of high-power sources and other high-power components has mainly led to choosing an RF frequency of 350–500 MHz. One MW-class of CW klystrons, circulators and dummy loads are already available, or are being developed at these frequencies.

3.5 High Field Performance

The design voltage per SC cavity in KEKB, CESR-III, BTCF and LHC is 1.5–2.2 MV, corresponding to a gradient of 5–6 MV/m, which can be obtained without any serious difficulty with the present technology in the SCRF community. Furthermore, long-term operations of TRISTAN, LEP, HERA, CEBAF, S-DALINAC and in other laboratories have shown excellent performance of SC cavities at 4–6 MV/m. At bench tests in vertical cryostats, the KEKB and CESR-III SC cavities reached more than 10 MV/m at a Q -value of 1×10^9 . After being assembled in a horizontal cryostat for a beam test in the TRISTAN-AR, the KEKB cavity reached 2.9 MV (9.8 MV/m).

4 BEAM TESTS

Before developing the SC cavities for the factories, the maximum stored current with SC cavities in the world was 69 mA, which was achieved in a beam test of TRISTAN SC cavities in the AR in 1988.²⁷ This is less than one tenth of the design current of the factories. It is an important step toward the factories to check if a much higher current beam can be stored with SC cavities. Other purposes of the beam tests are to test the properties and reliability of the cavity components with a high-current beam and to study the effect of the cavity on the beam. High-current beam tests of SC cavities have been conducted at a few laboratories, as briefly described below in chronological order.

4.1 CESR Beam Test

A prototype SC cavity for CESR-III was tested in CESR in 1994. The total required voltage of 7.5 MV was provided by CESR NC cavities (6 MV) and the SC cavity (1.5 MV). The maximum stored current was

220 mA (in 27 bunches) at a gap voltage of 1.4 MV (4.7 MV/m). The current limitation was not due to the SC cavity, but due to heating of the ring components. Beam currents of between 95–120 mA were also stored at a higher voltage of 1.8 MV (6 MV/m). The maximum power transferred to the beam was 155 kW. Up to 2 kW HOM power was absorbed by the ferrite absorbers.²⁸

4.2 LHC Cavity Test in SPS

A prototype LHC SC cavity was tested in SPS with a proton beam in 1995. It was operated at 1 MV and the peak current was 100 mA. The limitation was not by the cavity performance, but by the power source (tetrode amplifier).²⁶

4.3 KEKB Cavity Test in TRISTAN-AR

A dedicated machine time of about 10 weeks has been devoted to test a KEKB SC and two NC (ARES) cavities in TRISTAN-AR in 1996. It was found that both the SC and ARES RF systems work very well at a beam current of more than 500 mA.²⁹ Results with the SC cavity are discussed below. For most of the time for the SC cavity test, the required RF voltage was supplied by the SC cavity only, and the ARESs were detuned. A maximum beam current of 570 mA was stored at 1.2 MV (4.1 MV/m). A high current of 350 mA was also stored at 2.5 MV (8.5 MV/m), which is much higher than the design voltage of 1.5 MV for KEKB-HER. The current limitations were not determined by the cavity performance, nor by the beam instabilities, but by other things, such as saturation due to a balance between the beam lifetime and the injection rate (the case of 1.2 MV), or a heat-up of ring components (the case of 2.5 MV). The maximum RF power transferred to the beam was 160 kW with an input power of 270 kW. The maximum HOM power absorbed by the ferrite absorbers was 4.2 kW. If we compare the results with the design values of KEKB-HER, the voltage well exceeded the requirement. The stored current, the power transferred to the beam and the beam-induced power absorbed by the HOM dampers achieved more than half the design values. These limitations came not from the SC cavity performance, but from the AR. The loss factor estimated from the absorbed

power is consistent with a calculation at a bunch length of 1.5 cm and longer. No significant effects of the HOMs on the beam motion was found.^{30,10}

5 OPERATION AND CONTROL ISSUES

5.1 Trips

Operational experiences with SC cavities in storage rings³¹ have shown that one critical issue is a trip. In some cases, for example TRISTAN, a trip at one station does not necessarily cause a beam loss. In other cases, however, only one cavity trip results in a beam loss, even if there are many other operating cavities in the ring. This is particularly true for the factories due to the heavy beam-loading.

Most of the trips are characterized by a fast voltage drop to nearly zero and an increase of the reflection power, with a time constant much faster than the cavity filling time. In addition, in some cases it is accompanied by a gas burst. Thus, it has been suspected that the trips are related to a discharge. The frequency of the trips usually increases with time after a cool down as condensed gas on a cold surface becomes accumulated. Experiences at TRISTAN and other laboratories have shown that a warm-up of the cavities to room temperature, or even to about 50 K to degas the condensed gas, is very effective to suppress a trip. The trip rate, however, increased again with time.

At HERA, when a trip occurs, a high electron current was observed by a probe located near to the window of the coupler. Consequently, the trip is very probably triggered by a multipacting in the input couplers.³² It has been found at LEP and HERA that applying a DC bias between the inner and outer conductors effectively suppresses this type of trip.³³ A DC electric field affects the electron trajectory and changes the multipacting condition.

Keeping a good vacuum condition is also very important. In the first part of the beam test in the AR at KEK, the SC cavity could not be operated stably due to frequent trips: at that time the vacuum condition of the AR was too bad, since a large part of the ring had been opened to install hardware components to be tested. Prior to the second part of the experiment, the vacuum pumping power of the neighboring ducts was strengthened by a factor of about three; it is

estimated that the gas-flow rate to the cavity from the ring was reduced by one order. As things turned out, the frequency of the trips drastically decreased and stable operation continued for two weeks during the second experiment. It is considered that the improvement of the vacuum pressure contributed to this.³⁰

5.2 Phase and Amplitude Control

The relative RF phase between the two rings of a double-ring factory should be controlled with an accuracy of typically 1° . A relative phase error gives rise to a displacement of the colliding point. For those factories with a short bunch length and small β^* , even a small phase error reduces the luminosity, due to the hourglass effect.

It is also important to control the relative phase between all cavities in the same ring. A phase error in one cavity causes an extra input power to that cavity due to heavy beam-loading. For example, if the phase of one KEKB SC cavity is different from that of the others by 1° , an extra power of 30 kW is fed to that cavity to keep the cavity voltage constant. Furthermore, in the case that one high-power source feeds more than one cavity, an unbalance of wave-guide length and/or the loaded- Q value between the cavities can give rise to a large phase and amplitude error. Therefore, it is advantageous to have one high-power source per each cavity. It is also desired to control a low-level phase shifter for each high-power source, according to the phase error detected by an unbalance of the generator power and the accelerating voltage.

5.3 Bunch-gap Transient

In order to avoid ion-trapping in the electron ring, a bunch gap will be introduced at KEKB and PEP-II. The bunch gap, however, modulates the longitudinal bunch position. It changes the colliding point bunch-by-bunch, and can reduce the luminosity. The 5% gap in PEP-II changes the bunch phase by 10° corresponding to 17 mm, which is larger than the bunch length. The LHC beam also has bunch gaps. Although the displacement of the colliding point in LHC is negligible compared with the bunch length, the phase modulation causes capture losses during injection.

The phase modulation ($\Delta\phi$) is approximately given by³⁴

$$\Delta\phi = \frac{\omega}{2V_c} \frac{R}{Q} \times I\Delta t = \frac{P_b\Delta t}{2\cos\phi_s U},$$

where Δt is the length of the gap. Again, it is inversely proportional to the stored energy: a high stored energy is beneficial to reduce the phase modulation. The displacement of the colliding point can be reduced by introducing a corresponding gap in the positron ring, so that it makes a similar phase modulation. The compensation gap reduces the relative displacement to below 0.5° in KEKB, which is acceptable.³⁵ In addition to the compensation gap, the same input coupling factor was set for both rings in PEP-II to reduce the relatively large phase modulation to an acceptable level.³⁶ At LHC, the generator power will be modulated so as to suppress the phase modulation at injection.³⁴

5.4 Robinson Stability

The ratio of the beam-induced voltage on resonance (V_{br}) to the cavity voltage (V_c), $Y = V_{br}/V_c$, reflects the beam-loading effect on the RF system. For the factories it is typically in the region $Y = 2-5$, where a small margin exists for the stability criterion. Without a sufficient margin, the system can be unstable, due to a transient effect or cross talk between the amplitude-control and phase-lock loops.³⁷ An appropriate choice of the parameters, such as the loaded- Q value and/or the tuning angle, can relax the stability margin to some extent. The stability margin can be further increased by a direct RF feedback loop, which reduces the coupling impedance seen by the beam.³⁸

6 SC CRAB CAVITY FOR KEKB

For factories with finite angle crossing, it is a critical issue whether the luminosity and/or beam lifetime are degraded by beam-beam effects. The crab-crossing scheme^{39,40} (Figure 8) is considered to be a viable fall-back solution to the potential problems encountered with the finite angle crossing for KEKB.

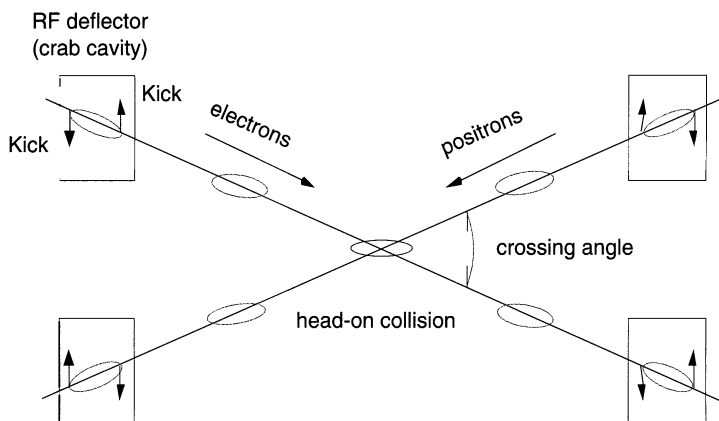

FIGURE 8 The crab-crossing scheme.

The requirements for the crab cavity are: (1) to provide a high transverse deflecting voltage, and (2) to be a damped cavity. A single-cell SC cavity operating in the TM₁₁₀ mode can provide necessary deflecting voltage for KEKB, although the surface peak field is about 20 MV/m, which is about twice that of the accelerating cavities. Furthermore, in addition to HOMs, a special care must be taken to those parasitic modes which have lower frequencies than or about the same as that of the operating mode: the fundamental TM₀₁₀ mode, TE₁₁₁ mode and the unwanted polarization of the TM₁₁₀ mode.

A SC squashed-crab cavity¹⁸ was developed under the KEK–Cornell collaboration. Figure 9 shows a schematic view of this cavity. It employs an extremely polarized cell (“squashed” cell) together with a coaxial beam pipe. All monopole and dipole parasitic modes, including the lower frequency modes, are extracted from the cavity through the beam pipes and damped by absorbers attached at the end of the beam pipes. The crabbing mode, the frequency of which is below the cut-off of the dipole travelling waves in the coaxial beam pipe, is well trapped in the cavity. A notch filter is attached at the coaxial beam pipe to prevent any TEM-coupled components of the crabbing mode from propagating to the absorbers, caused by some asymmetry due to machining errors or misalignment. The damping property was confirmed by calculations and model measurements.

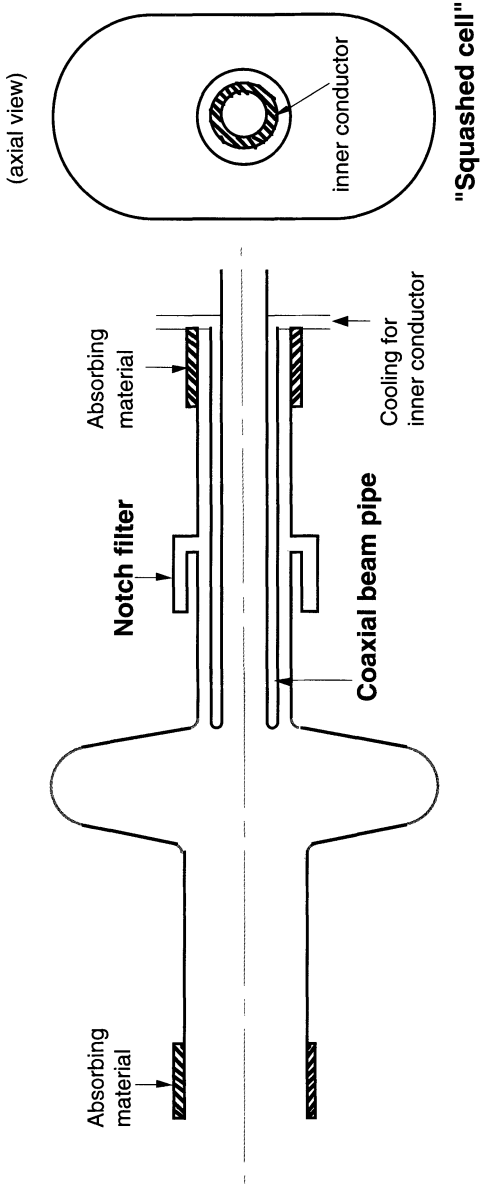

FIGURE 9 The SC squashed-crab cavity.¹⁸

Since the crab cavity has a quite different geometry, such as the squashed cell and the coaxial beam pipe, and is operating in a different mode compared with accelerating cavities, it is significant to test whether this cavity can yield a high field. A one-third scale niobium cavity (slightly polarized, but not squashed) with a coaxial beam pipe and a notch filter was made and measured at Cornell.⁴¹ At a surface peak field of 1 MV/m a multipacting was encountered, which is considered to have occurred at the coaxial beam pipe. However, the multipacting was completely processed away after an hour of RF processing. The maximum surface peak field was 25 MV/m, which exceeds the design field for KEKB. The R&D efforts are being continued at KEK. A one-third scale squashed niobium cavity (without coaxial pipe) was measured and the maximum surface peak field exceeded 40 MV/m.⁴² Thus, the squashed cell and the coaxial beam pipe were independently tested and the required high field was achieved in both cases; the feasibility of the crab cavity has been realistically demonstrated. The R&D is in progress, aiming at fabricating full-scale cavities for KEKB.

7 SUMMARY

The application of SC cavities to factories is very attractive for a high accelerating voltage, high stored energy and low impedance. Extensive R&D efforts have been made to develop the SC cavities for factories. Calculations and measurements have shown that HOMs are sufficiently damped with the proposed schemes. Two key hardware components, the HOM power absorbers and the high power input couplers, have been successfully developed. The SC cavity modules have been successfully tested with a high-current beam at a voltage much higher than the design value. The present record of the stored current is 570 mA. No fatal problem has been found to operate them with the high-current beam, and experiences have been accumulated to overcome trips. The next step for KEKB and CESR-III is to prepare for the commissioning scheduled in 1998 to 1999. Then long-term operational experience with a high-current beam will be obtained. The R&D work continues and is quite promising for the two future projects, LHC and BTF, and for the crab cavity for KEKB.

Acknowledgments

The author would like to thank Drs. H. Padamsee, S. Belomestnykh and D. Boussard, for kindly supplying information. He would also like to thank all his colleagues in the superconducting accelerating cavity group and the crab cavity group of KEKB. He would also like to thank Profs. S. Kurokawa and Y. Yamazaki for their encouragement.

References

- [1] "KEKB B-factory design report", June 1995, KEK Report 95-7 (1995).
- [2] "PEP-II, an asymmetric B factory", Conceptual Design Report, June 1993, LBL-PUB-5379, SLAC-418, CALT-68-1869, UCRL-ID-114055, UC-IIRPA-93-01.
- [3] D.L. Rubin, "CESR status and plans", in *Proc. 1995 Part. Accel. Conf.*, Dallas, USA, 1995, p. 481.
- [4] G. Vignola, "DAΦNE: the Frascati ϕ -Factory", in *Proc. 1991 Part. Accel. Conf.*, San Francisco, USA, 1991, p. 68.
- [5] L.M. Barkov *et al.*, "Status of the Novosibirsk phi-factory project", in *Proc. 1991 Part. Accel. Conf.*, San Francisco, USA, 1991, p. 183.
- [6] "Feasibility study report on Beijing tau-charm factory", IHEP-BTCF Report-03, October (1996).
- [7] CERN/AC/95-05 (1995).
- [8] D.L. Rubin, "CESR Status", in *Proc. 1997 Part. Accel. Conf.*, Vancouver, Canada, 1997 (to be published).
- [9] S. Mitsunobu, K. Asano, T. Furuya, M. Ohara, T. Tajima, T. Takahashi, Y. Ishi and Y. Kijima, "Superconducting cavity development for KEK B-factory", in *Proc. Int. Workshop on B Factories (BFWS92)*, KEK, Japan, 1992, KEK Proceedings 93-7 (1993) p. 140.
- [10] T. Furuya, K. Akai, K. Asano, E. Ezura, K. Hara, K. Hosoyama, A. Kabe, Y. Kojima, S. Mitsunobu, Y. Morita, H. Nakai, H. Nakanishi, T. Tajima, T. Takahashi, S. Yoshimoto, S.C. Zhao, Y. Ishi, Y. Kijima, T. Murai and K. Sennyu, "Beam test of a superconducting damped cavity for KEKB", in *Proc. 1997 Part. Accel. Conf.*, Vancouver, Canada, 1997 (to be published); KEK Preprint 97-18 (1997).
- [11] H. Padamsee, P. Barnes, C. Chen, W. Hartung, J. Kirchgessner, D. Moffat, R. Ringrose, D. Rubin, Y. Samed, D. Saraniti, J. Sears, Q.S. Shu and M. Tigner, "Design challenges for high current storage rings", *Part. Accel.* **40** (1992) 17.
- [12] S. Belomestnykh, P. Barnes, E. Chojnacki, D. Coffman, R. Ehrlich, J. Graber, W. Hartung, T. Hays, R. Kaplan, J. Kirchgessner, E. Nordberg, H. Padamsee, D. Rubin and J. Sears, "Superconducting RF system for the CESR luminosity upgrade: design, status, and plans", in *Proc. 5th European Part. Accel. Conf.*, Barcelona, Spain, 1996, p. 2100.
- [13] T. Kageyama, "Grooved beam pipe for damping dipole modes in RF cavities", in *Proc. 8th Sympo. on Accel. Sci. and Tech.*, Saitama, Japan, 1991, p. 116.
- [14] R.A. Rimmer, "RF cavity development for the PEP-II B factory", in *Proc. Int. Workshop on B Factories (BFWS92)*, KEK, Japan, 1992, KEK Proceedings 93-7 (1993) p. 123.
- [15] T. Kageyama, K. Akai, N. Akasaka, E. Ezura, H. Mizuno, F. Naito, H. Nakanishi, H. Sakai, Y. Takeuchi, Y. Yamazaki and T. Kobayashi, "Development of high-power ARES cavities", in *Proc. 1997 Part. Accel. Conf.*, Vancouver, Canada, 1997 (to be published).

- [16] S. Bartalucci, R. Boni, A. Gallo, L. Palumbo, R. Parodi, M. Serio and B. Spataro, "The RF cavity for DAFNE", in *Proc. 1993 Part. Accel. Conf.*, Washington, DC, USA, 1993, p. 778.
- [17] T. Shintake, "The choke mode cavity", *Jpn. J. Appl. Phys.* **31** (1992) L1567.
- [18] K. Akai, J. Kirchgessner, D. Moffat, H. Padamsee, J. Sears, T. Stowe and M. Tigner, "Crab cavity for the B-factories", in *Proc. B Factories*, SLAC, USA, 1992, SLAC-400 (1992) p. 181.
- [19] T. Tajima, K. Asano, T. Furuya, M. Izawa, S. Mitsunobu, T. Takahashi, N. Gamo, S. Iida, Y. Ishi, Y. Kijima, S. Kokura, M. Kudo, K. Sennyu, S. Tachibana, H. Takashina and N. Taniyama, "Development of HOM damper for B-factory (KEKB) superconducting cavities", in *Proc. 1995 Part. Accel. Conf.*, Dallas, USA, 1995, p. 1620.
- [20] S. Belomestnykh, W. Hartung, J. Kirchgessner, D. Moffat, H. Muller, H. Padamsee and V. Veshcherevich, "Comparison of the predicted and measured loss factor of the superconducting cavity assembly for the CESR upgrade", SRF 950406-04, Laboratory of Nuclear Studies, Cornell University.
- [21] Y. Yamazaki and T. Kageyama, "A three cavity system which suppresses the coupled-bunch instability associated with the accelerating mode", *Part. Accel.* **44** (1994) 107.
- [22] F. Pedersen, "RF cavity feedback", in *Proc. B Factories*, SLAC, USA, 1992, SLAC-400 (1992) p. 192.
- [23] P. Corredoura, L. Sapozhnikov and R. Tighe, "RF feedback development for the PEP-II B factory", in *Proc. 4th European Part. Accel. Conf.*, London, UK, 1994, p. 1954.
- [24] S. Mitsunobu, K. Asano, T. Furuya, Y. Ishi, Y. Kijima, K. Sennyu, T. Tajima and T. Takahashi, "High power test of the input coupler for KEK-B SC cavity", in *Proc. 7th Workshop on RF Superconductivity*, Gif-sur-Yvette, France, 1995, p. 735.
- [25] S. Belomestnykh, P. Barnes, E. Chojnacki, R. Ehrlich, W. Hartung, T. Hays, R. Kaplan, J. Kirchgessner, E. Nordberg, H. Padamsee, S. Peck, P. Quigley, J. Reilly, D. Rubin and J. Sears, "Development of superconducting RF for CESR", in *Proc. 1997 Part. Accel. Conf.*, Vancouver, Canada, 1997 (to be published).
- [26] D. Boussard (private communication).
- [27] K. Akai, "Beam tests and operation of superconducting cavities", in *Proc. 4th Workshop on RF Superconductivity*, KEK, Japan, 1989, KEK Report 89-21 (1990) p. 189; KEK Preprint 89-179 (1990).
- [28] H. Padamsee, P. Barnes, S. Belomestnykh, K. Berkelman, M. Billing, R. Ehlich, G. Flynn, Z. Greenwald, W. Hartung, T. Hays, S. Henderson, R. Kaplan, J. Kirchgessner, J. Knobloch, D. Moffat, H. Muller, E. Nordberg, S. Peck, M. Pisharody, J. Reilly, J. Rogers, D. Rice, D. Rubin, D. Sagan, J. Sears, M. Tigner and J. Welch, "Beam test of a superconducting cavity for the CESR luminosity upgrade", in *Proc. 1995 Part. Accel. Conf.*, Dallas, USA, 1995, p. 1515.
- [29] Y. Funakoshi and K. Akai, "High beam current experiments for the KEKB conducted at the TRISTAN accumulation ring", in *Proc. 1997 Part. Accel. Conf.*, Vancouver, Canada, 1997 (to be published); KEK Preprint 97-62 (1997).
- [30] T. Tajima, K. Akai, K. Asano, T. Furuya, K. Hara, K. Hosoyama, A. Kabe, Y. Kojima, S. Mitsunobu, Y. Morita, T. Takahashi and S.C. Zhao, "Beam test results on HOM absorber of superconducting cavity for KEKB", in *Proc. 1997 Part. Accel. Conf.*, Vancouver, Canada, 1997 (to be published); KEK Preprint 97-87 (1997).
- [31] K. Akai, "Performance of SRF systems in storage rings", *Part. Accel.* **40** (1992) 1.
- [32] B. Dwersteg, A. Matheisen, W.-D. Moller, D. Proch, D. Renken and J. Sekutowicz, "Operating experience with superconducting cavities in the HERA E-ring", in *Proc. 7th Workshop on RF Superconductivity*, Gif-sur-Yvette, France, 1995, p. 151.

- [33] H.P. Kindermann, E. Haebel, M. Stirbet and V. Veshcherevich, "Status of RF power couplers for superconducting cavities at CERN", in *Proc. 5th European Part. Accel. Conf.*, Barcelona, Spain, 1996, p. 2091.
- [34] D. Boussard, "RF power requirements for a high intensity proton collider", in *Proc. 1991 Part. Accel. Conf.*, San Francisco, USA, 1991, p. 2447.
- [35] K. Akai and E. Ezura, "Simulation of influence of a bunch gap in TRISTAN-II", in *Proc. 4th European Part. Accel. Conf.*, London, UK, 1994, p. 1141; KEK Preprint 94-55 (1994).
- [36] H. Schwarz and R. Rimmer, "RF system design for the PEP-II B factory", in *Proc. 4th European Part. Accel. Conf.*, London, UK, 1994; SLAC-PUB-6539, LBL-35797 (1994).
- [37] F. Pedersen, "A novel RF cavity tuning feedback for heavy beam loading", *IEEE Trans. Nucl. Sci.*, **NS-32** No. 5, (1985) 2138.
- [38] D. Boussard, "Control of cavities with high beam loading", *IEEE Trans. Nucl. Sci.*, **NS-32** No. 5 (1985) 1852.
- [39] V.B. Palmer, SLAC-PUB 4707 (1988).
- [40] K. Oide and K. Yokoya, *Phys. Rev. A* **40** (1989) 315.
- [41] K. Akai, J. Kirchgessner, D. Moffat, H. Padamsee, J. Sears and M. Tigner, "Development of crab cavity for CESR-B", in *Proc. 1993 Part. Accel. Conf.*, Washington, DC, USA, 1993, p. 769; KEK Preprint 93-17 (1993).
- [42] Y. Morita, K. Hosoyama, K. Hara, A. Kabe, Y. Kojima and H. Nakai, "RF test of the 1/3 scale model crab cavity", in *Proc. 8th Workshop on RF Superconductivity*, Padova, Italy, 1997 (to be published).